



Hardie® Trim

Installation Requirements

EFFECTIVE SEPTEMBER 2025

IMPORTANT: FAILURE TO FOLLOW JAMES HARDIE WRITTEN INSTALLATION INSTRUCTIONS AND COMPLY WITH APPLICABLE BUILDING CODES MAY VIOLATE LOCAL LAWS, AFFECT BUILDING ENVELOPE PERFORMANCE AND MAY AFFECT WARRANTY COVERAGE. FAILURE TO COMPLY WITH ALL HEALTH AND SAFETY REGULATIONS WHEN CUTTING AND INSTALLING THIS PRODUCT MAY RESULT IN PERSONAL INJURY. BEFORE INSTALLATION, CONFIRM YOU ARE USING THE CORRECT PRODUCT INSTRUCTIONS BASED ON YOUR HARDIE™ ZONE. VISIT HARDIEZONE.COM OR CALL 1-866-942-7343 (866-9-HARDIE) FOR MORE INFORMATION.

STORAGE & HANDLING:

Store flat and keep dry and covered prior to installation. Installing siding wet or saturated may result in shrinkage at butt joints. Carry trim on edge. Protect edges and corners from breakage. James Hardie is not responsible for damage caused by improper storage and handling of the product.

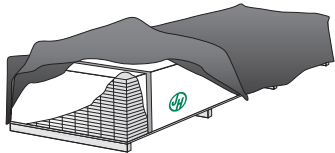

⚠ CUTTING INSTRUCTIONS

OUTDOORS

1. Position cutting station so that airflow blows dust away from the user and others near the cutting area.
2. Cut using one of the following methods based on jobsite requirements:
 - a. Best: Electric or pneumatic fiber cement shears (not recommended for products thicker than 7/16 in.).
 - b. Better: Circular saw equipped with a a Hardie™ Blade saw blade and attached vacuum dust collection system.
 - c. Good: Circular saw equipped with with a Hardie™ Blade saw blade and supplemental ventilation.

INDOORS

- DO NOT grind or cut with a power saw indoors. Cut using shears (manual, pneumatic or electric) or the score and snap method, not recommended for products thicker than 7/16 in.
- During clean-up of dust and debris, wet dust and debris down with a fine water mist, apply a dust reducing sweeping compound in sufficient quantities, or use a vacuum to collect dust and debris. DO NOT use compressed air. DO NOT dry sweep without first applying a dust reducing control measure.
 - For best performance when cutting with a circular saw, Jame Hardie recommends using Hardie™ Blade saw blades.
 - Go to jameshardie.com/pros-hub for additional cutting and dust control recommendations.

IMPORTANT: The Occupational Safety and Health Administration (OSHA) regulates workplace exposure to silica dust. For construction sites, OSHA has deemed that cutting fiber cement with a circular saw having a blade diameter less than 8 inches and connected to a commercially available dust collection system per manufacturer's instructions results in exposures below the OSHA Permissible Exposure Limit (PEL) for respirable crystalline silica, without the need for additional respiratory protection.

If you are unsure about how to comply with OSHA silica dust regulations, consult a qualified industrial hygienist or safety professional, or contact your James Hardie technical sales representative for assistance. James Hardie makes no representation or warranty that adopting a particular cutting practice will assure your compliance with OSHA rules or other applicable laws and safety requirements.

Hardie® Trim is a decorative non-load bearing trim product.

Do not use Hardie® Trim to replace any structural component.

TABLE OF CONTENTS

GENERAL REQUIREMENTS	Page 1
FLASHING/CLEARANCE REQUIREMENTS	Page 2
FASTENING	Page 3
Face Nailing Requirements.....	Page 3
INSTALLATION	Page 4-8
Trimming Corners.....	Page 4
Openings.....	Page 4
Band Boards.....	Page 4
Frieze.....	Page 4
Batten Boards.....	Page 5
Fascia.....	Page 6
Hardie™ Trim Tabs.....	Page 7-8
FINISHING	Page 9

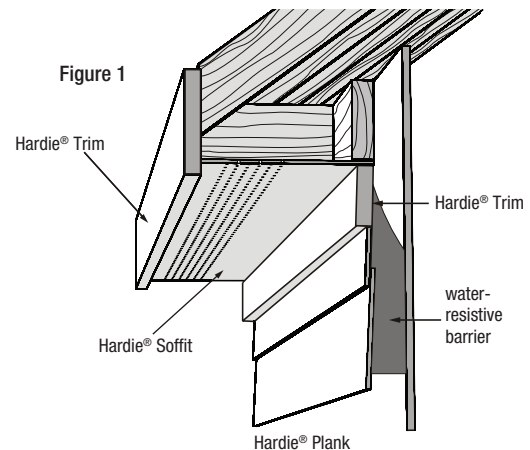

GENERAL REQUIREMENTS

- Wood or steel framing or structural panels must be provided for attaching Hardie® Trim.
- Follow all applicable codes when installing Hardie® Trim.
- DO NOT install Hardie® Trim, such that they may remain in contact with standing water.



FLASHING/CLEARANCE REQUIREMENTS

LEGEND

- Hardie® Product
- Hardie® Trim
- Weather Barrier
- Roofing Felt

Slabs, Paths, Steps to Trim

Figure 2

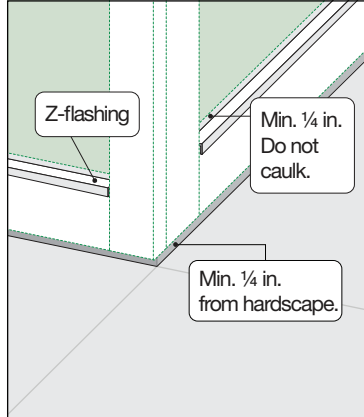

Trim to Grade

Figure 3

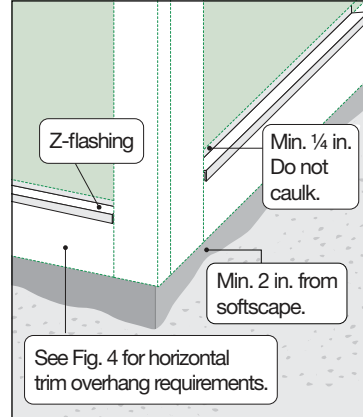

Horizontal Trim Overhang

Figure 4

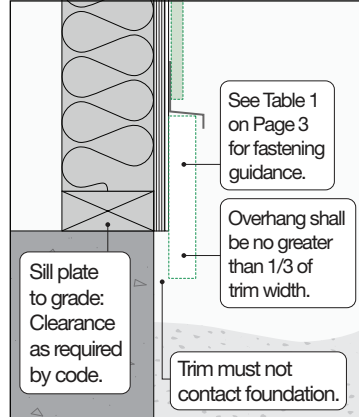

Deck to Trim

Figure 5

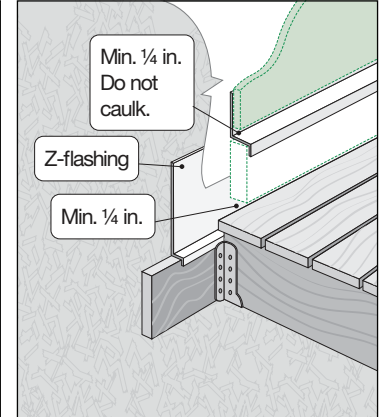

Roof to Wall

Figure 6

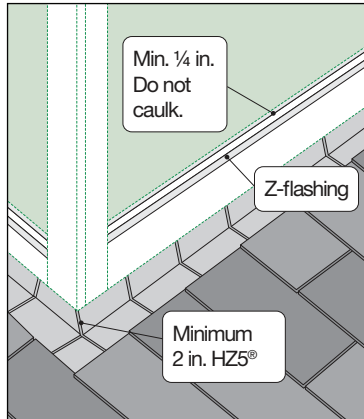

Horizontal Flashing

Figure 7

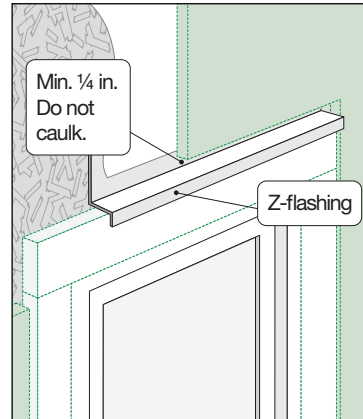

Drip Edge

Figure 8 For fascia installation, see page 6.

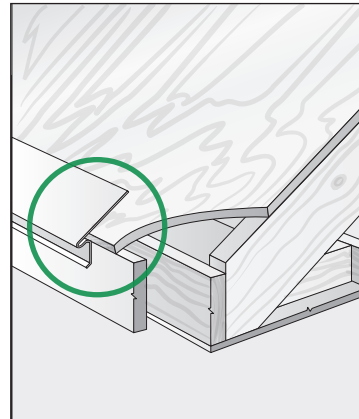

Mortar/Masonry

Figure 9

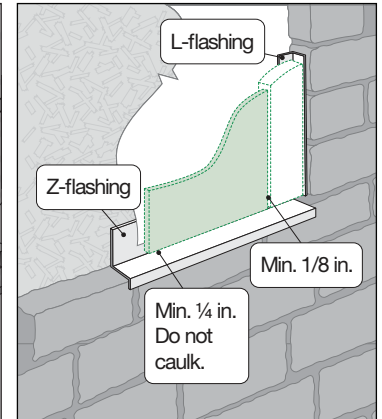

Block Penetration

Figure 10

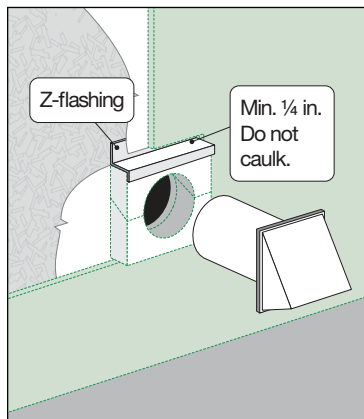

Valley/Shingle Extension

Figure 11





GENERAL FASTENING REQUIREMENTS

Fasteners must be corrosion resistant, galvanized, or stainless steel. Electro-galvanized are acceptable but may exhibit premature corrosion. Unless otherwise directed, James Hardie recommends the use of quality, hot-dipped galvanized nails. James Hardie is not responsible for the corrosion resistance of fasteners.

Stainless steel fasteners are recommended when installing Hardie® products near the ocean, large bodies of water, or in very humid climates. Note: Ring shank (not smooth) shall be used when specifying stainless steel nails.

Manufacturers of ACQ and CA preservative-treated wood recommend spacer materials or other physical barriers to prevent direct contact of ACQ or CA preservative-treated wood and aluminum products. Fasteners used to attach Hardie™ Trim Tabs, aluminum trim, or flashing to preservative-treated wood shall be of hot dipped zinc-coated galvanized steel or stainless steel and in accordance to the latest versions of the IRC/IBC.

- Consult applicable product evaluation or listing for correct fastener type and placement to achieve specified design wind loads.
- NOTE: Published wind loads may not be applicable to all areas where Local Building Codes have specific jurisdiction. Consult James Hardie Technical Services if you are unsure of applicable compliance documentation.
- Drive fasteners perpendicular to siding and framing.
- Fastener heads should fit snug against siding (no air space).

PNEUMATIC FASTENING

Hardie® products can be hand nailed or fastened with a pneumatic tool. Pneumatic fastening is highly recommended. Set air pressure so that the fastener is driven snug with the surface of the trim. A flush mount attachment on the pneumatic tool is recommended. This will help control the depth the nail is driven. If setting the nail depth proves difficult, choose a setting that under drives the nail. (Drive under-driven nails snug with a smooth faced hammer - Does not apply for installation to steel framing).

FACE NAILING REQUIREMENTS

Use 2 in. minimum 16 ga. finish nails to attach Hardie® Trim to wood frame construction. ET&F or equivalent fasteners or screws may be used to attach Hardie® Trim to steel frame construction.

Fastening instructions are similar for all applications. When using finish nails, position nails no closer than 1/2 in. from the edges of the trim and for all other fasteners no closer than 3/4 in. Fasteners must be no closer than 1 in. from ends and spaced a maximum of 16 in. O.C. Ensure trim is adequately fastened.

James Hardie recommends using stainless steel finish nails when installing Hardie® Trim products.

TABLE 1: MINIMUM FASTENER GUIDE FOR FINISH NAILING

	PRE-BUILT CORNER	SITE BUILT CORNER	OTHER AREAS (E.G., WINDOW TRIM AND BAND BOARDS)
4 in.	1 nail every 16 in. to attach boards together + 1 nail every 16 in. each board	2 nails every 16 in.	2 nails every 16 in.
6 in.	1 nail every 16 in. to attach boards together + 2 nails every 16 in. each board	2 nails every 16 in.	2 nails every 16 in.
8 in.	-	3 nails every 16 in.	3 nails every 16 in.
12 in.	-	4 nails every 16 in.	3 nails every 16 in.

Use a 2 in. finish nail to fasten trim together. Longer finish nails may bend.

*If applicable building codes require more clearance, follow applicable building code.

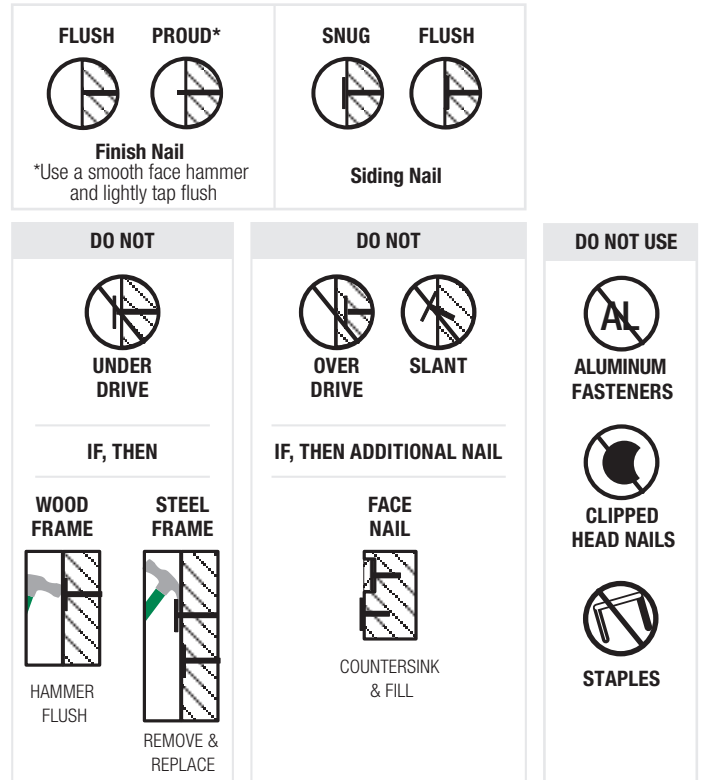
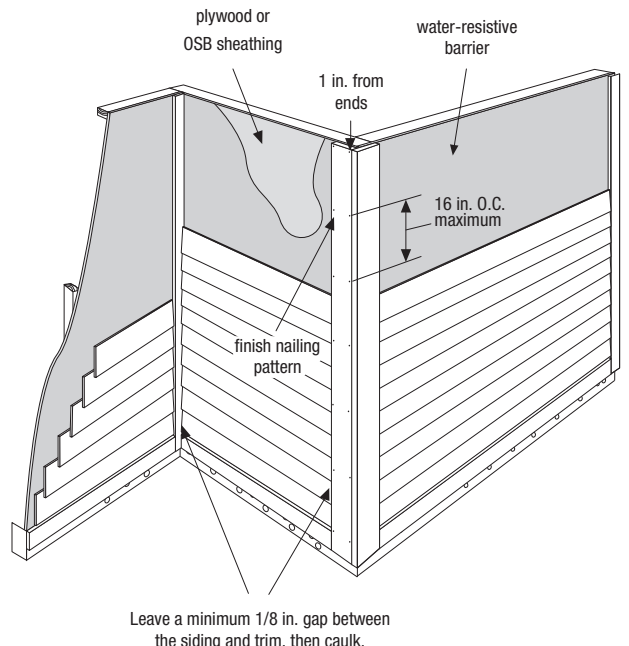

Figure 11



INSTALLATION

TRIMMING CORNERS

When installing corners or other vertical trim, position boards on the wall and attach (Figure 12).

Pre-built Corners

Alternatively, corners can be pre-built off the wall using 2 in. finishing nails. Each side of the pre-built corner must be secured to the wall (Figure 13).

Figure 12

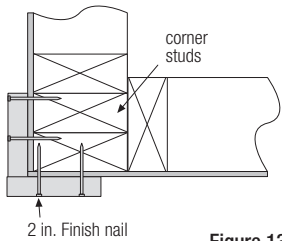
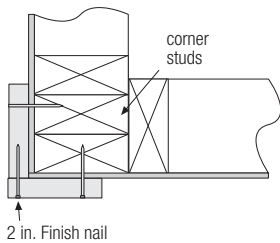
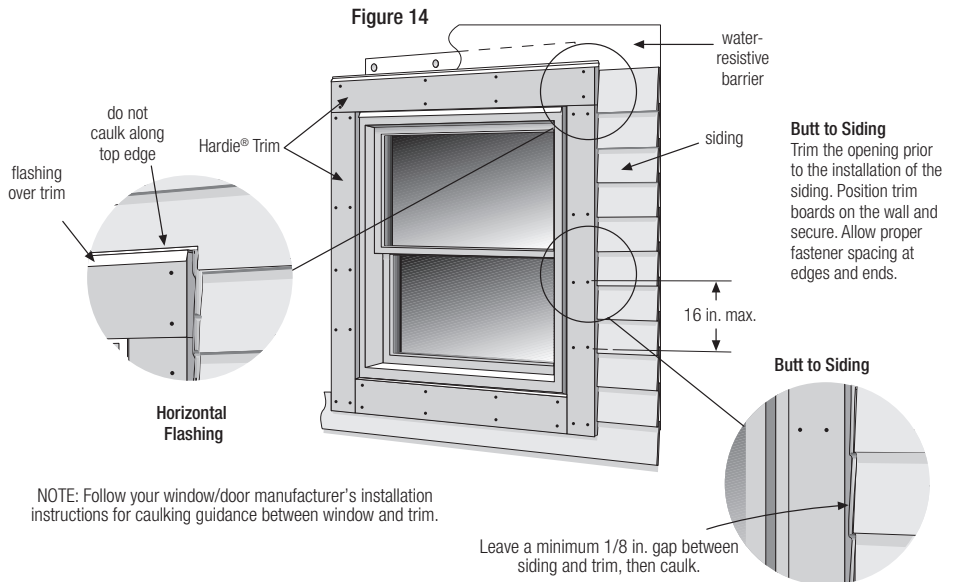

Figure 13



TRIM APPLICATION FOR WINDOWS, DOORS & OTHER OPENINGS

Flashing over horizontal trim is required per code for all installation methods. (Figure 14).



BAND BOARD

For band board applications, flashing is required over the trim (Figure 15).

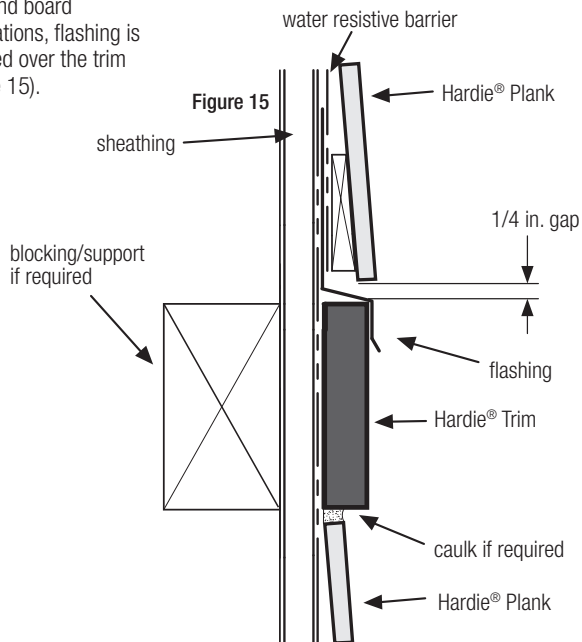

FRIEZE

Hardie® Trim can be used as frieze (Figure 16).

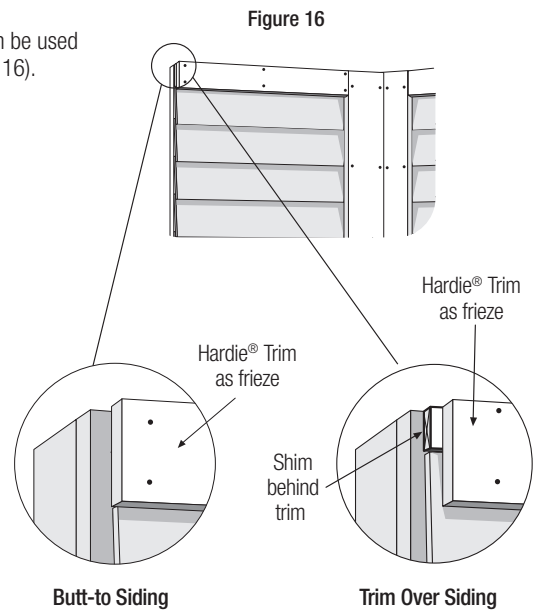



BATTEN BOARDS

HORIZONTAL PANEL JOINTS

At horizontal panel joints Hardie® Trim Batten must be installed according to option 1 or 2 below. When installing Hardie® Trim Batten horizontally, they must be installed as a panel joint according to option 2.

Option 1

Figure 17 - No horizontal band board - Make a 22.5 - 45 degree weather cut, in the Hardie® Trim Batten, just above the 1/4 in. clearance between panels.

Option 2

Figure 18 - Horizontal Band Board - Install a horizontal band board at the top of the bottom panel. Butt the lower batten to the band board and start the top batten at the bottom edge of the top panel. Maintain a 1/4 in. clearance above horizontal flashing.

Figure 17

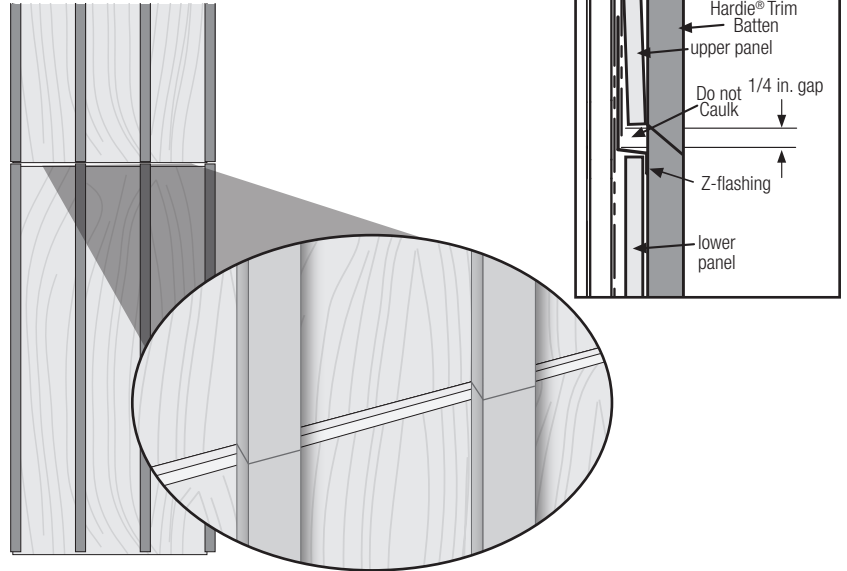
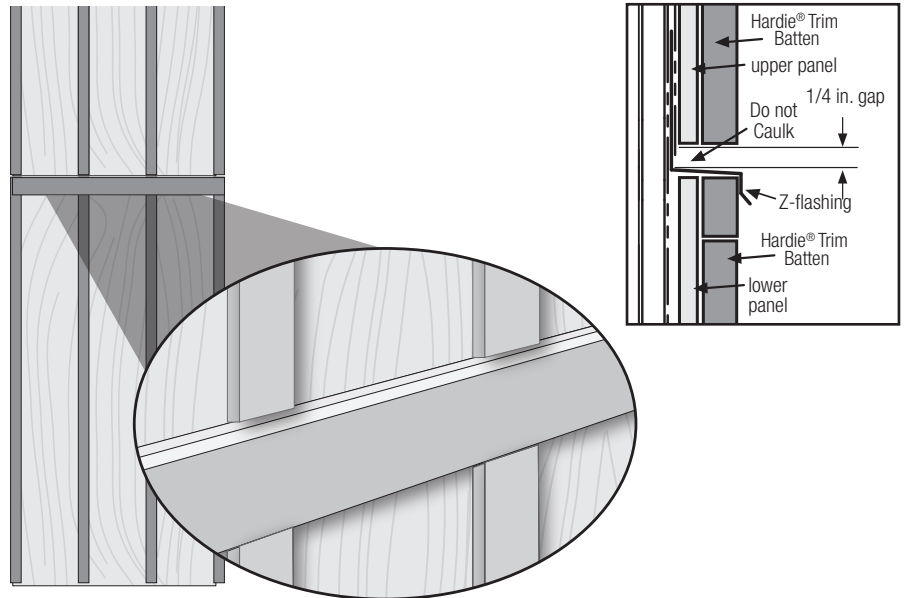

Figure 18





FASCIA

Hardie® Trim is a decorative non-load bearing trim product. Do not use Hardie® Trim to replace any structural component. Hardie® Trim can be fastened directly over a 2x sub-fascia or directly to rafter tails. Check local building code for relevant codes.

Option 1 - Over sub-fascia: (Figure 19)

When installing Hardie® Trim over solid 2x sub-fascia use minimum 2 in., 16 gauge corrosion resistant finish nails. (see fastener guide below).

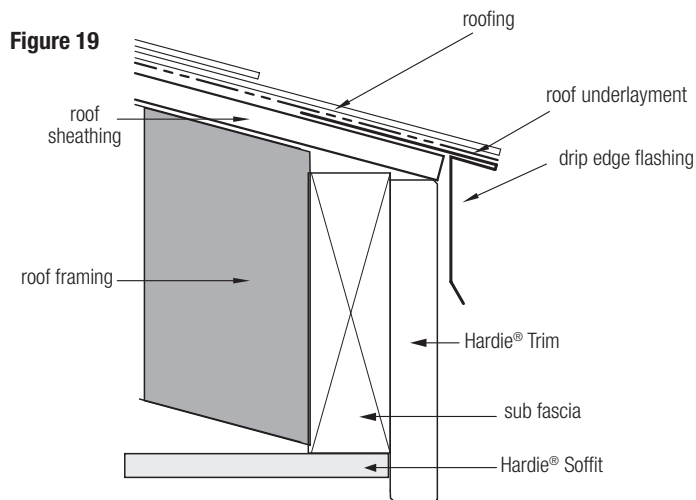

Gutters:

James Hardie recommends the use of rain gutters whenever possible. **DO NOT USE HARDIE® TRIM AS THE STRUCTURAL ATTACHMENT FOR GUTTERS.**

Use gutter hangers that attach through the roof sheathing; into a rafter tail; or other structural member.

Soffit

When installing Hardie® Soffit, additional framing/blocking may be needed depending on application. Refer to Hardie® Soffit installation instructions for guidance.

Option 2 - Direct to rafter tails: (Figure 20)

When installing Hardie® Trim without the presence of a 2x sub-fascia, a minimum 8d siding corrosion resistant nails must be used to attach Hardie® Trim. DO NOT use finish nails. (refer to fastener guide below).

TABLE 2: FASCIA FASTENER GUIDE

Hardie® Trim	FASTENER SPACING	
	Direct to Rafter (min 8d siding)	Over 2x Sub-fascia
6 in.	2 nails every rafter spaced max 24 in. O.C.	2 nails spaced maximum 16 in. O.C.
8 in.	3 nails every rafter spaced max 24 in. O.C.	3 nails spaced maximum 16 in. O.C.
10 in.	--	4 nails spaced maximum 16 in. O.C.

Figure 20

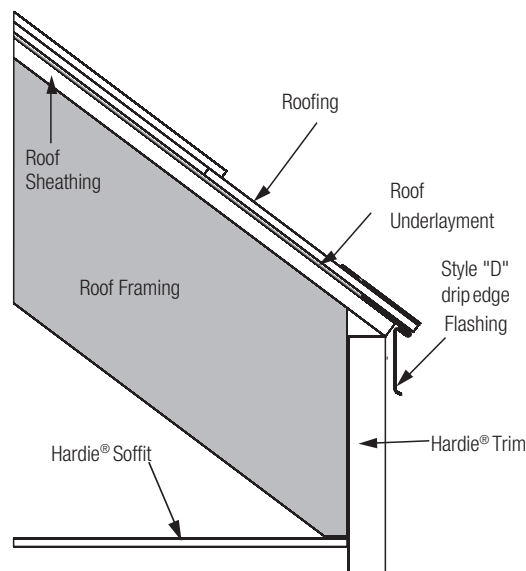



HARDIE™ TRIM TABS

FASTENER REQUIREMENTS

For Corners, Band Boards, Windows, and Door Applications:

Hardie® Trim may be installed with Hardie™ Trim Flat Tabs and Hardie™ Trim Corner Tabs which provide concealed fastening. Only Hardie™ Trim Flat and Corner Tabs can be used with Hardie® Trim to create a concealed fastening.

Step 1: Attach Hardie™ Trim Flat Tabs to the back side of the trim using four, 18 ga. 1/2 in. L x 1/4 in. W narrow crown corrosion resistant staples, equally spaced in one row, positioned no closer than 1/2 in. from trim edges using a pneumatic staple gun (Figures 21, 22).

Step 2: For wood frame construction, attach the trim to the building with minimum 2, 6d siding nails fastened through the Hardie™ Trim Flat Tabs (Figure 23). ET&F or equivalent fasteners may be used to attach the Hardie™ Trim Flat Tabs to steel frame construction.

Fastener spacing will vary based on application. Refer to fastener table on page 9. Refer to specific sections in these instructions for required fastener spacing by application (window, band board, etc.).

For Fascia, Rake, and Frieze board Applications:

Hardie™ Trim tabs cannot be used in fascia, rake, or frieze applications. Follow Face nailing fastening specifications.

Installation of Hardie™ Trim tabs in Coastal Regions:

James Hardie requires that stainless steel staples & fasteners be used when installing Hardie™ Trim Tabs in coastal regions.

Installation of Hardie™ Trim Tabs over Pressure Treated Lumber: Hardie™ Trim tabs shall not come in direct contact with ACQ or CA preservative-treated wood. Refer to the General Fastening section of this document for further information.

Hardie® Trim with ColorPlus® Technology: Remove the laminate sheet as soon as possible after attaching the trim to the building.

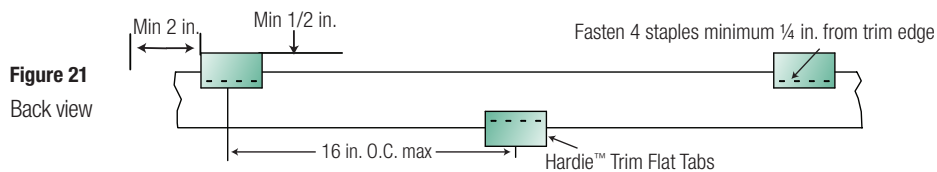

Figure 21
Back view

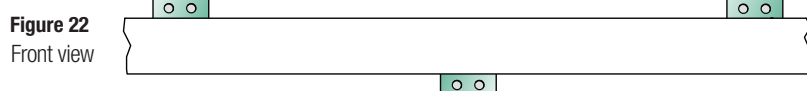

Figure 22
Front view

Figure 23

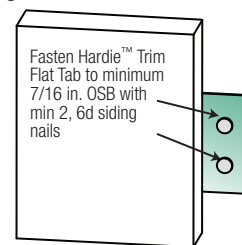
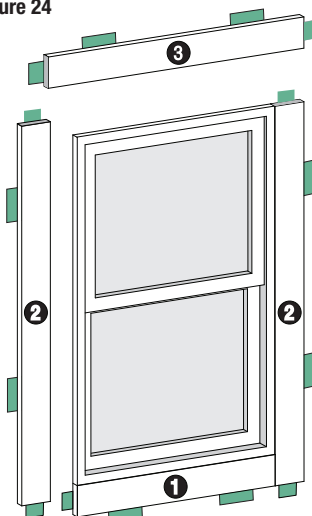

Figure 24

Trim Application for Windows, Doors & Other Openings

Trim the opening prior to the installation of the siding. Place a Flat Tab at the end of each trim and one tab every 16 in. OC. Attach the trim and Flat Tabs around the opening as shown in Figure 24. Use 16 ga. galvanized 2 in. long finish nails to ensure proper fastening if needed.



Flush Hardie™ Trim Flat and Corner Tabs	Hardie™ Trim Flat and Corner Tabs	
Siding nail attaches tab to the wall.	Do not under drive nails.	Only use staples to fasten Hardie™ Trim Flat and Corner Tabs to the trim.

NOTE: Follow your window/door manufacturers installation instructions for caulking guidance between window and trim.



TRIMMING CORNERS

When using Hardie™ Trim tabs pre-build outside corners off the wall.

- Attach Hardie™ Trim Corner Tabs to the back side of the trim using eight (8) - 18 ga. 1/2 in. L x 1/4 in. W narrow crown corrosion resistant staples using a pneumatic stapler. Ensure the Hardie™ Trim Corner Tabs are fastened tight and straight to the trim (Figure 25).
- For wood frame construction, attach trim to building using min. 6d siding nails fastened through the Hardie™ Trim Corner Tabs attached to minimum 7/16 in. OSB (Figure 26).
- Attach a Hardie™ Trim Corner Tab 1 in. from each ends and every 20 in. O.C.
- TIP: Creating a jig for the work station is recommended to ensure corners are fastened securely and straight (Figure 27).

Figure 25

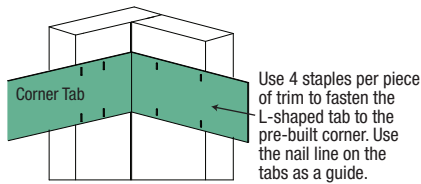

Figure 26

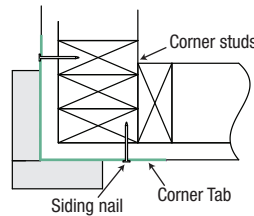
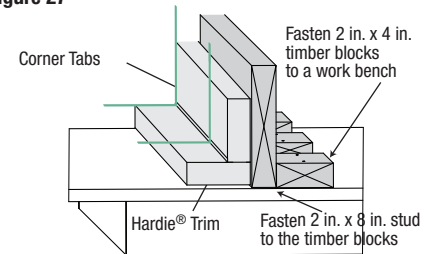

Figure 27



BAND BOARD

Terminate ends of the Band Board into Trim or Siding or miter cut the edges of the trim at the corners of the building. Place a Hardie™ Trim Flat Tab at the end of each trim and one tab every stud at a maximum of 16 in. O.C. The Hardie™ Trim Flat Tabs should be attached to the trim in an alternating pattern to the top and bottom of the band board (Figures 21, 22). Use 16 ga. galvanized 2 in. long finish nails to ensure proper fastening if needed.

TABLE 3: TRIM TAB FASTENER TABLE

Application	Framing Material Tab is Nailed into	Fastener (tab to framing)	Fastener (tab to trim)	Max Tab Spacing (inches on center)
Flat Tab	Wood Stud (minimum G=0.42)	One 6d corrosion resistant siding nail installed through center of tab into framing	Four 18 ga. X 1/2 in. long X 1/4 in. wide corrosion resistant crown staples, equally spaced in one row	16
	Minimum APA rated 7/16 in. OSB	Two 4d ring shank corrosion resistant siding nails equally spaced installed through tab into framing		
	Minimum 20 gauge steel	One No. 8 X 1 in. long X 0.323 in. head diameter screw (corrosion resistant) installed through flange into framing		
Corner Tab	Wood Stud (minimum G=0.42)	On each flange, Install one 6d corrosion resistant siding nail through tab into framing	For each piece of trim, install four 18 ga. X 1/2 in. long X 1/4 in. wide corrosion resistant crown staples, equally space in two rows	20
	Minimum APA rated 7/16 in. OSB	On each flange, Install two 4d ring shank corrosion resistant siding nails through tab into framing		
	Minimum 20 gauge steel	On each flange, Install one No. 8 X 1 in. long X 0.323 in. head diameter screw (corrosion resistant) through tab into framing		





FINISHING

CUT EDGE TREATMENT

IMPORTANT: Caulk, paint or prime all field cut edges. Hardie™ Touch-up Kits are required to touch-up Hardie® products with ColorPlus® Technology finishes.

CARE & MAINTENANCE

Routinely perform the following to help maintain the appearance and performance of Hardie® siding and trim products:

- Washing down the exterior surfaces every 6 to 12 months with a garden hose or low pressure water spray to remove dirt and debris.
- Re-applying of exterior finishes.
- Maintaining the exterior envelope and connections including joints, penetrations, flashings, and sealants (caulking) to prevent moisture entry behind the siding.
- Cleaning out gutters, blocked pipes, and overflows as required.
- Prune vegetation to prevent contact with the siding.
- Ensuring required external ground clearances and drainage slopes are maintained.

CAULKING

For best results, use an Elastomeric Joint Sealant complying with ASTM C920 Grade NS, Class 25 or higher or a Latex Joint Sealant complying with ASTM C834. Caulking/Sealant must be applied in accordance with the caulking/sealant manufacturer’s written instructions. **Note: Some caulk manufacturers do not allow “tooling.”**

PAINTING

DO NOT use stain, oil/alkyd base paint, or powder coating on Hardie® products. Factory primed products by James Hardie must be painted within 180 days of installation. 100% acrylic topcoats are recommended. Do not paint when Hardie® products are wet. Follow paint manufacturer’s instructions and application rates. Back rolling is recommended if spray application is used.

COLORPLUS TECHNOLOGY CAULKING, TOUCH-UP & LAMINATE

- Care should be taken when handling and cutting Hardie® products with ColorPlus® Technology finishes. During installation, use a wet soft cloth or soft brush to gently wipe off any residue or construction dust left on the product, then rinse with a garden hose.
- Touch-up nicks, scrapes and nail heads using the ColorPlus® Technology touch-up applicator. Touch-up should be used sparingly. If large areas require touch-up, replace the damaged area with a new piece of siding with ColorPlus® Technology.
- Laminate sheet must be removed immediately after installation of each course.
- Terminate field-cut edges into trim where possible, and caulk.
- Treat all other field-cut edges using the ColorPlus® Technology edge coaters. Color matched caulks and touch-up kits are available from your Hardie® product dealer.

Note: James Hardie does not warrant the usage of third party touch-up or paints used as touch-up on Hardie® products with ColorPlus® Technology finishes.

Problems with appearance or performance arising from use of third party touch-up paints or paint products that are not part of Hardie® Touch-up Kits will not be covered by the ColorPlus® Technology Limited Finish Warranty.

PAINTING HARDIE® SIDING AND TRIM PRODUCTS WITH COLORPLUS® TECHNOLOGY FINISHES

When repainting Hardie® products with ColorPlus® Technology finishes, James Hardie recommends the following regarding surface preparation and topcoat application:

- Ensure the surface is clean, dry, and free of any dust, dirt, or mildew.
- Repriming is normally not necessary.
- 100% acrylic topcoats are recommended.
- DO NOT use stain, oil/alkyd base paint, or powder coating on Hardie® products.
- Apply finish coat in accordance with paint manufacturer’s written instructions regarding coverage, application methods, and application temperature.
- DO NOT caulk nail heads when using Hardie® products with ColorPlus® Technology finishes, refer to the ColorPlus® Technology touch-up section.

SILICA WARNING **DANGER:** May cause cancer if dust from product is inhaled. Causes damage to lungs and respiratory system through prolonged or repeated inhalation of dust from product. Refer to the current product Safety Data Sheet before use. The hazard associated with fiber cement arises from crystalline silica present in the dust generated by activities such as cutting, machining, drilling, routing, sawing, crushing, or otherwise abrading fiber cement, and when cleaning up, disposing of or moving the dust. When doing any of these activities in a manner that generates dust you must (1) comply with the OSHA standard for silica dust and/or other applicable law, (2) follow James Hardie cutting instructions to reduce or limit the release of dust; (3) warn others in the area to avoid breathing the dust; (4) when using mechanical saw or high speed cutting tools, work outdoors and use dust collection equipment; and (5) if no other dust controls are available, wear a dust mask or respirator that meets NIOSH requirements (e.g. N-95 dust mask). During clean-up, use a well maintained vacuum and filter appropriate for capturing fine (respirable) dust or use wet clean-up methods - never dry sweep.

WARNING: This product can expose you to chemicals including respirable crystalline silica, which is known to the State of California to cause cancer. For more information go to P65Warnings.ca.gov.

RECOGNITION: Hardie® Trim boards may be installed as an equal alternative to conventional trim permitted for use in; 2006, 2009, 2012, 2015, 2018, & 2021 International Building Code, Section 1403.1, and the 2006, 2009, 2012, 2015, 2018, & 2021 International Residential Code for One- and Two-Family Dwellings, Section R703.1.