



**Unlimited Possibilities**  
to Create Your Original.



# CONTENTS

## E-SERIES PRODUCT OVERVIEW

Performance & Durability .....	2
Contemporary Style .....	5
Unlimited Combinations .....	6
Unlimited Exteriors .....	7
Unlimited Interiors .....	12
Exterior & Interior Trim Options .....	16
Unlimited Views .....	18
Glass .....	20
Stormwatch® Protection .....	21
Grilles .....	22
Insect Screens .....	24
Blinds & Shades .....	25
Window Hardware & Smart Home Solutions .....	26
Patio Door Hardware .....	28
Environmental Responsibility .....	30

## E-SERIES WINDOWS & PATIO DOORS

Casement Windows .....	32
Casement Windows .....	34
French Casement Windows .....	36
Push Out Casement Windows .....	38
Awning Windows .....	48
Awning Windows .....	50
Push Out Awning Windows .....	52
Double-Hung Windows .....	56
Double-Hung Windows .....	58
Double-Hung Insert (RetroFit) Windows .....	60
Double-Hung Sash Replacement Kits .....	62
Bay & Bow Windows .....	80
Gliding (Slide-By) Windows .....	92
Specialty (Auxiliary) Windows .....	98
Hinged Patio Doors .....	106
Gliding Patio Doors .....	142

## E-SERIES TECHNICAL DATA

Installation Materials .....	154
Product Performance .....	158

Andersen Corporation, including its subsidiaries, has been named a 2019 ENERGY STAR® Partner of the Year – Sustained Excellence Award winner, the highest honor given by ENERGY STAR for continued leadership in protecting the environment through superior energy efficiency achievements.



“ENERGY STAR” is a registered trademark of the U.S. Environmental Protection Agency.



**Andersen**<sup>®</sup>  
ARCHITECTURAL  
COLLECTION



**E-SERIES**  
WINDOWS & DOORS

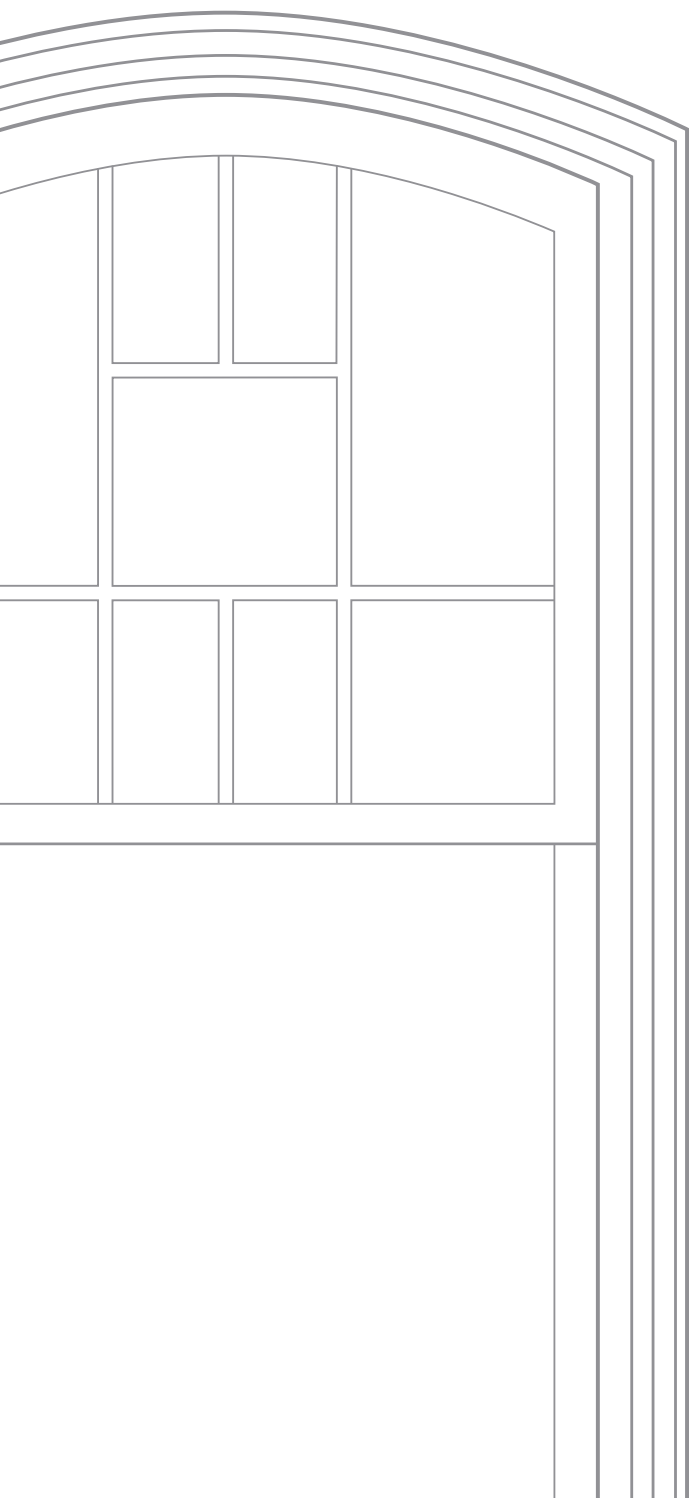

## Create Distinction

**Whether you're looking for traditional or contemporary style, performance or innovation, you'll find it in the Andersen<sup>®</sup> Architectural Collection.**

Our E-Series windows & patio doors, as part of the Architectural Collection, are made to your exact specifications for unmatched flexibility and design freedom.

These premier products allow you to create custom shapes, dramatic sizes and striking combinations to set your work apart. You can choose from 50 standard exterior colors, custom colors and anodized finishes, plus a range of interior wood species and beautiful interior stains. Or, if your customers want something even more distinctive, we can source virtually any wood species they desire.

If it's possible, it's possible with E-Series windows and doors.

For more information, visit [andersenwindows.com/e-series](https://andersenwindows.com/e-series).

# Engineered for Performance & Durability

## Energy-saving glass for any climate

Andersen makes windows and patio doors with options that make them ENERGY STAR® v. 6.0 certified throughout the United States.

Visit [andersenwindows.com/energystar](http://andersenwindows.com/energystar) for more information and to verify that the product with your glass option is ENERGY STAR certified in your area.



## Protection for coastal areas

E-Series windows and patio doors with Stormwatch® Protection meet building code requirements in many Gulf and Atlantic coast states. See your local building code official for specific requirements. Visit [andersenwindows.com/coastal](http://andersenwindows.com/coastal) for more information.



## Built for years to come

Our renowned Owner-2-Owner® limited warranty is fully transferrable and not prorated, making it one of the best coverage plans available — which means it can add resale value for your customers. It's also supported by the industry's largest service network.\*



## Low-maintenance exteriors

Baked-on silicone polyester enamel exteriors offer virtually maintenance-free performance and durability. They're warranted for 10 years against chalking and color change and for 20 years against cracking, checking, peeling, flaking, blistering and loss of adhesion.\*

# Made Strong

Aluminum is a distinguishing element that enables us to offer the strength, beauty and design freedom for which E-Series products are known. Through decades of innovation, we have elevated the extruded aluminum-clad window and door category and perfected a made-to-order process that is unsurpassed.

## Strength

We harness the full strength of aluminum with heavy gauge, extruded aluminum-clad wood sash and frames. Our thick cladding offers greater structural capabilities than thinner, roll-form aluminum, while providing a superior exterior finish that resists the elements of inclement weather, abrasion and impact.\*

## Beauty

Aluminum offers a smooth finish and versatility in design that enables us to create windows and doors with distinctive character and unparalleled beauty. It provides an essential foundation for our quality, baked-on silicone polyester finish, and it enables us to offer a broad array of unique accessory metals to create or recreate the architectural style you need. And beauty doesn't stop on the outside — we give you the design freedom you need to create a look of distinction both inside and out.

## Versatility

Aluminum's strength and versatility allow us to offer beautiful made-to-order design solutions for practically any combination of shapes and styles you can imagine. We offer dozens of exterior accessory metals to match any architectural style, and our colorful 2-, 3- and 4-tone exteriors truly broaden your creative palette.

## Durability

Our aluminum cladding withstands nature's toughest elements — the extrusions slide onto the wood and are secured independently, allowing both wood and aluminum to expand and contract naturally. Our products are engineered to open, close, support, swing or slide reliably day after day.\*

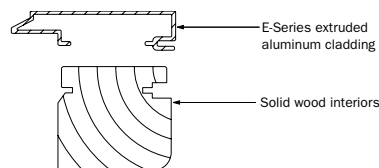

A solid wood core and extruded aluminum cladding give E-Series windows both strength and flexibility in many design applications.



E-Series casement window with terratone exterior color.

\* Visit [andersenwindows.com/warranty](http://andersenwindows.com/warranty) for details.



E-Series casement, awning, picture and transom windows with black exteriors.

# Contemporary Style

Modern home styles incorporate clean lines, simple forms and open floor plans. They often feature floor-to-ceiling windows or doors with narrow profiles to maximize light and view, have multiple units arranged in rectangular groupings and use dark colors or metal finishes. E-Series products are available in these options to let you create a contemporary style.



## Contemporary Designs

Dark colors and narrow profile options on windows, patio doors and even grille options offer a truly contemporary style.



Interior of door shown above with 3<sup>11</sup>/<sub>16</sub>" contemporary panel profile. Interior detail at right shows contemporary grille profile in black with a black spacer bar.

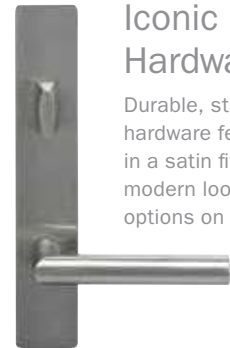

## Iconic Modern Hardware

Durable, stainless steel FSB® hardware features clean lines in a satin finish for a thoroughly modern look. See FSB hardware options on page 29.



## Sleek Interiors

High-quality, factory-applied interior finishes offer convenience along with beauty. For a modern look, choose a black or anodized silver painted interior.

## Bring Your Vision to Life

Andersen has done extensive research into many architectural styles and how windows and patio doors play a critical role in achieving them. We've compiled it all into our Home Style Library. Whether you're looking for a modern home style or something more traditional, our library shows how easily you can achieve each style with our Andersen® products. To view our complete Home Style Library, visit [andersenwindows.com/stylelibrary](http://andersenwindows.com/stylelibrary).



Miesian Modern



Industrial Modern



International Modern

# Unlimited Combinations

E-Series windows and doors are made to your exact design specifications. Because we make your window or door especially for you, and since our options are virtually limitless, you have the advantage of combining shapes, sizes and styles for new construction or remodeling applications.

## Building Blocks

Our complete window and door styles are your building blocks for making any architectural statement. We give you the products and the design freedom you need to create the perfect solution for your project whether residential or commercial, new construction or remodeling. Unique shapes in varying combinations create focal points that become defining architectural elements.

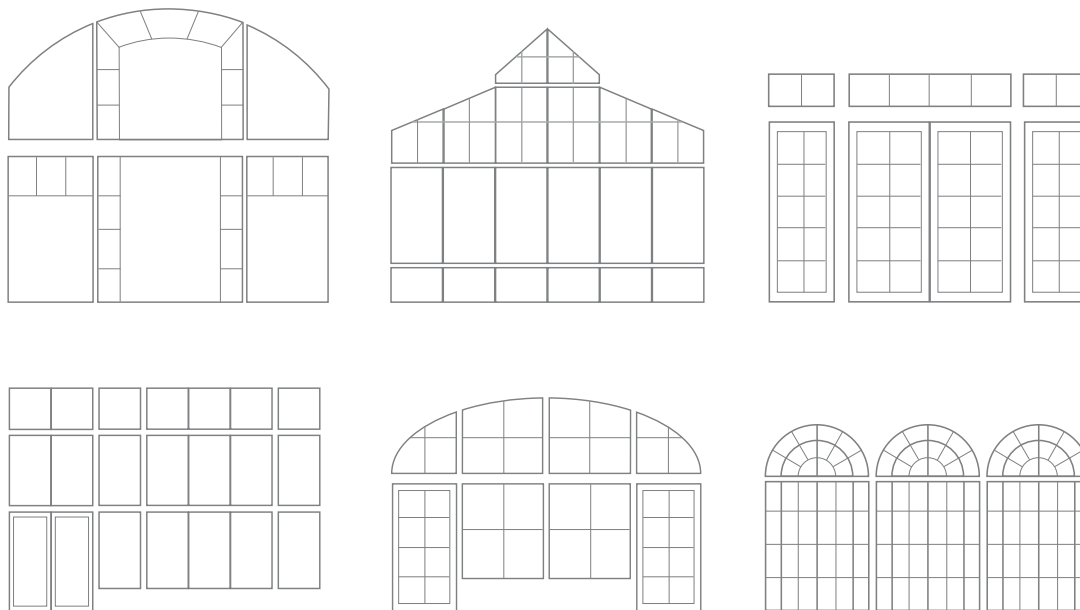

## Sizing Options

We believe you shouldn't have to settle for "close enough". Our made-to-order process enables us to make your windows and doors to the specific size you need. So when you go from inspirational sketch to architectural drawing, know that we will fulfill your design needs. We provide a thorough range of sizes for most applications and offer custom sizing anytime you need it.



E-Series picture windows with pine interiors.

---

# Unlimited Exteriors

Color enhances your design and is a vital element of every architectural style. We believe it shouldn't have to cost more which is why our 50 exterior colors, an industry-leading modern palette, are available at no additional cost. Add to that our 2-, 3- and 4-tone exteriors and set your E-Series windows and doors apart from the rest.

If your inspiration comes from an autumn leaf, a river-washed stone, a glass of fine wine or even a classic car, we will bring it to life with our custom color capabilities. And for a look of distinction, we offer seven spectacular anodized finishes that truly shine.



E-Series casement, picture and transom windows with custom exteriors.



E-Series picture and specialty windows with cinnamon toast exteriors.

# 50 Exterior Colors

Our exclusive line of exterior colors offers a broad spectrum of quality, baked-on, silicone polyester enamel exteriors that meet the AAMA 2604 specification. AAMA 2605 color compliance is also available\*. Our limited warranty covers exteriors for 10 years against chalking and color change and 20 years against cracking, checking, peeling, flaking, blistering and loss of adhesion\*\*.



\* AAMA 2605 finishes are available in any of our 50 colors, or select a custom color of your choice.

\*\* Visit [andersenwindows.com/warranty](http://andersenwindows.com/warranty) for details.

Printing limitations prevent exact color duplication. See your Andersen supplier for actual color samples.

## 2-, 3- and 4-Tone Exteriors

With our 2-, 3- and 4-tone color combinations, the sky's the limit. Mix and match up to four of our 50 exterior colors for a combination look that's all your own.



Country Blue and Stormy Blue



Sage, Moss and Canvas

## 7 Anodized Finishes

Choose from a spectacular selection of anodized finishes. Anodizing is a process that penetrates the aluminum like a stain penetrates wood. The result is a rich, lustrous metallic appearance that cannot peel or flake and is not affected by sunlight.\* This process produces a harder, more durable finish that makes this a perfect choice for high-traffic areas in commercial or residential buildings.



Black



Dark Bronze



Copper



Medium Bronze



Light Bronze



Champagne



Clear Anodized

## Custom Colors

While our large selection of exterior colors covers a lot of ground, inspiration comes in infinite hues. Let us match a paint chip, a photograph, a favorite work of art to bring your dream color into the light of day.



E-Series outswing patio doors with sidelights and transoms with custom exterior color.

\* Visit [andersenwindows.com/warranty](http://andersenwindows.com/warranty) for details.  
Printing limitations prevent exact finish replication. See your Andersen supplier for actual finish samples.



E-Series casement and picture windows with custom interior color.

---

## Unlimited Interiors

Natural wood adds character to your design and defines a room's character while creating a warm, comfortable space that leaves a lasting impression. For infinite possibilities, we offer distinctive wood varieties and will source virtually any other wood species your design demands.

All of our wood selections can be finished in one of our interior stains or painted options. And with our stain-matching capabilities, you can trust us to customize a finish to meet your design needs.



E-Series picture windows with black interiors.

# Distinctive Wood Selections

Our distinctive woods add uncommon flair to any room. Each option has its own character, grain and staining capabilities, so you can select one that makes your windows stand out or one that blends seamlessly with your interior décor.

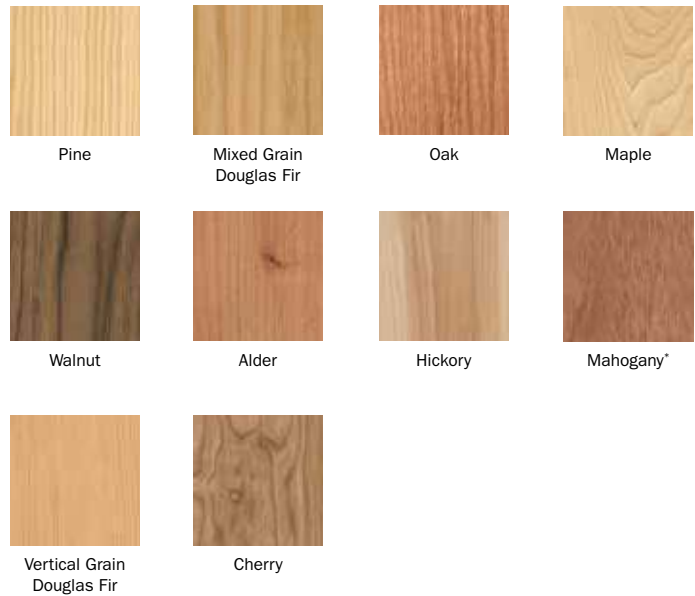

## Custom Wood Interiors

If a unique wood species is required to complete your project, we will try to source any variety that meets our production standards and your needs.

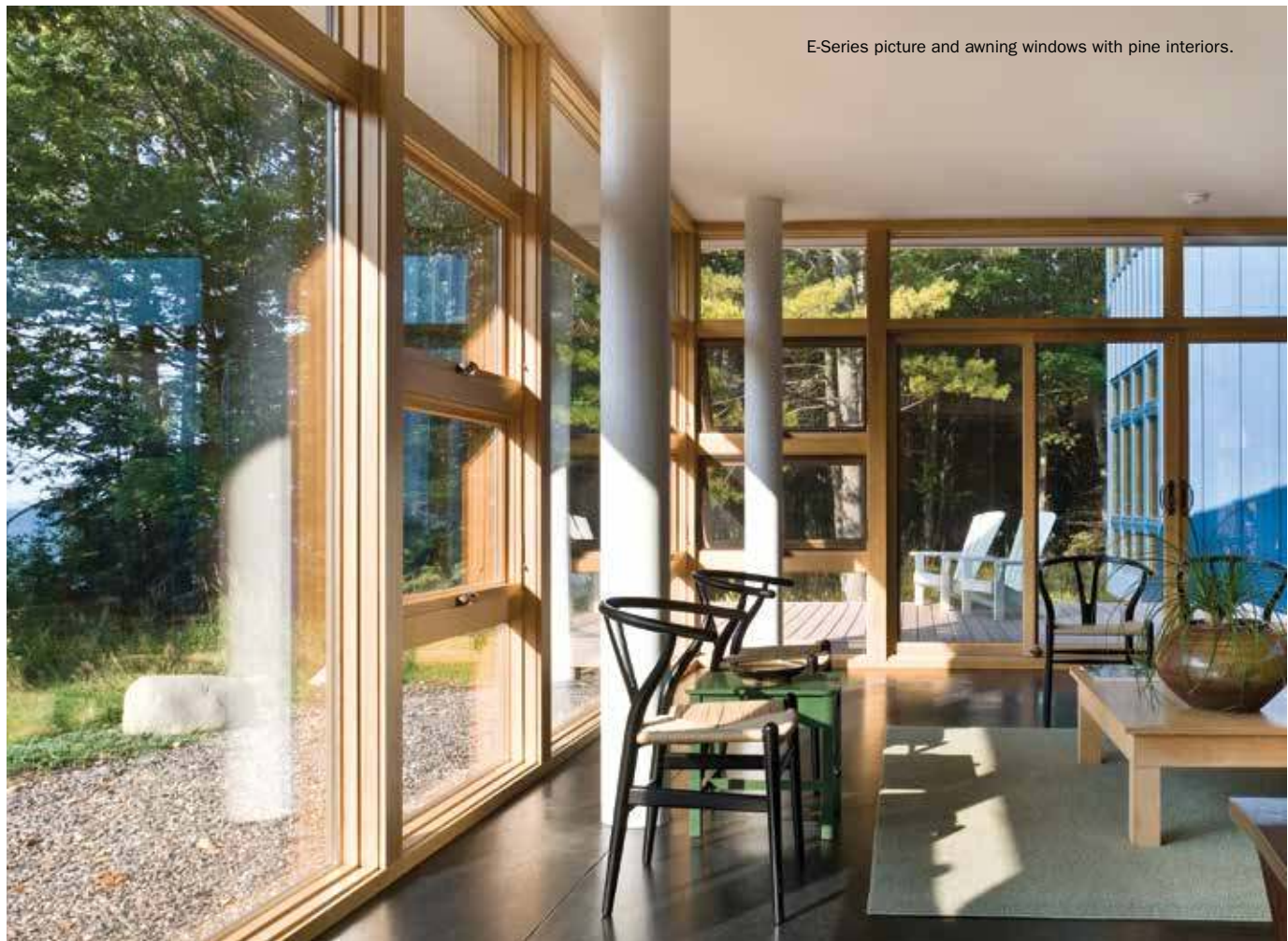

\* Actual wood species is either Sapele or Sipo, both non-endangered species grown in Africa, with color and characteristics similar to Central American mahoganies. Wood species shown are unfinished.

Naturally occurring variations in grain, color and texture of wood make each window one of a kind. We cannot guarantee consistency in wood grain and/or color within a particular species, product or project.

# Variety of Interior Finishes

Our high-quality, factory-applied stains offer you convenience along with beauty. Before staining, each wood component is treated with a preservative and insect repellent and dried thoroughly. We apply two coats of polyurethane for a long-lasting,\* durable finish, and because every exposed edge is stained before the window is assembled, you get a complete, consistent finish. Choose from nine stain colors. If you prefer a painted interior, choose one of our painted or primed options.

## Stained Interior Options



All stained interior finish options are shown on pine.

## Painted Interior Options



Painted interior options are available on pine.

## Custom Stains, Paints & Color Matching

When only a specific tint will do, we will create one for you, matching existing woodwork, interior furnishings or other items for just the right finish to your design.

\* Visit [andersenwindows.com/warranty](http://andersenwindows.com/warranty) for details.

\*\* Dark bronze and black also available on maple.

† Anodized silver available on maple only.

Please note that custom finishes and primed option require additional finishing. Some nail and staple holes may need to be filled prior to applying the final finish. Printing limitations prevent exact finish and color replication. See your Andersen supplier for actual finish and color samples.

# Exterior & Interior Trim Options

Details take your project from ordinary to extraordinary. The perfect finishing touches make every window and patio door an irreplaceable part of any home or commercial building. We offer the trim and accessory metals that make the final details of your project easier to complete and more beautiful to look at.

## Exterior Trim

Designed to add depth and traditional appeal, our exterior trim options extend outward from the window or door frame, casting a shadow line consistent with true historical applications. Choose from our extended selection of flat and profiled casings, brick mould casings and sill nose. Match or contrast the trim with your windows and doors in any of our 50 exterior colors, custom colors and anodized finishes.



3 1/2" backband and bead casing and 1 1/2" sill nose shown on casement



3 1/2" flat casing shown on hinged inswing patio door



2" brick mould and 1 1/2" sill nose shown on casement



3 1/2" brick mould and 1 1/2" deep sill nose shown on double-hung

## Interior Trim Components



- 1 1/2" x 3 3/4" Fluted Casing
- 2 1 1/16" x 2 3/4" Colonial Casing (WM366)
- 3 1 1/16" x 2 3/4" Colonial Casing (WM356)
- 4 1 1/16" x 2 3/4" Ranch Casing (WM324)
- 5 2 1/2" Plinth Block
- 6 3 1/2" Plinth Block



### Wood Casing

A subtle touch around the perfect window or door makes your view even more special. Choose from four different casings and add plinth blocks at the corners for just the right touch of detail.



### Drywall Returns

We offer drywall returns in three depths: 1 1/16", 9/16" and 7/16".

### Extension Jamb

Pre-installed, dimensional extension jamba save time on jobsites and help enable a perfect installation. Available in all wood species, extension jamba can accommodate a wide variety of wall conditions.



E-Series casement windows with white interiors.

---

# Unlimited Views

Whether your design demands performance, clarity or architectural detail, we have the glass and divided light solutions to make your views spectacular. For performance needs in a variety of environments, we offer a multitude of glass options, including our High-Performance Low-E4® glass and our exclusive Stormwatch® impact-resistant product systems for severe weather conditions.\*

And for visual impact, made-to-order decorative glass and grilles give you infinite possibilities, so your design will be as original as your inspiration.

\* See your local code official for building code requirements in your area.



E-Series picture and transom windows with White interiors.

E-Series single-hung and picture windows with mixed grain Douglas fir interiors.



# Glass Options

We offer a multitude of glass options to meet all of your design needs. Whether you're in need of energy efficiency or resistance to harsh weather conditions, we provide the solutions for you.

## Low-E4® Glass

Our standard glass option provides excellent insulation from heat and cold. Compared to ordinary dual-pane glass, High-Performance Low-E4 glass is up to 44% more energy efficient in winter and up to 57% more efficient in summer.\* Or consider Sun glass with its soft, glare-controlling tint.

## Low-E4 SmartSun™ Glass

SmartSun glass combines performance with clarity — letting more light in and keeping more heat out. It blocks 95% of the sun's damaging ultraviolet rays. Enjoy the performance benefits of tinted glass without the loss of visibility.

## Low-E4 PassiveSun® Glass

Great solution for colder climate zones where higher heat gain is desired. It allows a higher amount of the sun's heat to pass into the home, making it an ideal solution for passive solar applications.



A removable translucent film shields glass from damage and simplifies finishing and cleaning on the jobsite.

## HeatLock® Technology

Our HeatLock coating can increase the energy efficiency of any E-Series window or door with Low-E4 or SmartSun glass. Applied to the room-side glass surface, it reflects heat back into the home and improves U-Factors, which can help the window or door meet ENERGY STAR® requirements.

## Triple-Pane Glass

Three panes of glass combined with Low-E coatings can provide enhanced energy performance. Adding triple-pane glass to one of our products can produce a lower U-Factor than using regular dual-pane glass.

## Laminated Glass

Laminated glass offers sound protection, forced entry and impact resistance. It reduces unwanted outside noise, making it ideal for locations like airports and high-volume traffic areas.

## Decorative & Specialty Glass

Select from our decorative glass collections found online at [andersenwindows.com/artglass](http://andersenwindows.com/artglass) or combine beveled, frosted, grooved, colored or textured glass with three coming options to create your own design. Specialty glass includes tinted glass, spandrel glass and Mapes panels as well as rain, reeded and obscure glass options.

### PERFORMANCE COMPARISON OF E-SERIES GLASS OPTIONS

GLASS	ENERGY		LIGHT	
	U-FACTOR	SOLAR HEAT GAIN COEFFICIENT	VISIBLE LIGHT TRANSMITTANCE	UV PROTECTION
	How well a product prevents heat from escaping.	How well a product blocks heat caused by sunlight.	How much visible light comes through a product.	How well a product blocks ultraviolet rays.
SmartSun™	● ● ● ○	● ● ● ●	● ● ● ○	● ● ● ●
SmartSun™ with HeatLock*	● ● ● ●	● ● ● ●	● ● ○ ○	● ● ● ●
Low-E4*	● ● ● ○	● ● ● ○	● ● ● ○	● ● ● ○
Low-E4* with HeatLock*	● ● ● ●	● ● ● ○	● ● ● ○	● ● ● ○
Sun	● ● ● ○	● ● ● ●	● ○ ○ ○	● ● ● ○
PassiveSun®	● ● ● ○	● ○ ○ ○	● ● ● ○	● ● ● ○
Triple-Pane with Low-E coatings on two surfaces	● ● ● ●	● ● ● ○	● ● ● ○	● ● ● ●
Clear Dual-Pane	● ○ ○ ○	○ ○ ○ ○	● ● ● ●	○ ○ ○ ○

Center of glass performance only. Ratings based on glass options available as of January 2019. Visit [www.andersenwindows.com/energystar](http://www.andersenwindows.com/energystar) for ENERGY STAR® map and NFRC total unit performance data.

\* Winter and summer values are based on comparison of E-Series 3866 double-hung window U-Factor to the U-Factor for clear dual-pane glass non-metal frame default values from the 2006, 2009, 2012, 2015 and 2018 International Energy Conservation Code "Glazed Fenestration" Default Tables. See your Andersen supplier for actual glass samples.

ENERGY STAR® is a registered trademark of the U.S. Environmental Protection Agency.

# Stormwatch® Protection

Designed for use in coastal areas, these systems combine monolithic or insulated laminated glass with structural enhancements to meet or exceed the stringent code requirements of ASTM and TAS testing protocols\*. You get the performance you need with the design options you want.

## Performance & Durability

- Impact-resistant glass provides windborne debris protection,† reduced sound transmission and burglar resistance
- Designed to satisfy:
  - AAMA/WDMA/CSA 101/I.S.2/A440-08 & -11
  - Large missile impact test ASTM E1886/E1996
  - Miami-Dade TAS 201, 202, 203 (excluding inswing patio doors)
  - Peace of mind with 24/7 protection

**PG65\*\***  
**PERFORMANCE**

E-Series Casement 3060 HP Impact DP+65/-75  
(AAMA/WDMA/CSA 101/I.S.2/A440-08 & -11)

## Product Availability

Choose from a variety of coastal windows including casement, awning, double-hung† and fixed windows. Impact-resistant double-hung windows utilize two or more snuggers applied



to the sill, creating a structural connection between the lower sash and frame. Simply close and lock the window and it's ready to withstand even the toughest weather conditions.\*

We also offer a variety of coastal patio doors including inswing patio doors (impact-resistant insulated glass options only), outswing patio doors and French gliding patio doors. Surface bolts are required for impact certification of double doors.

Plus, you can select any of our 50 exterior colors, anodized finishes or custom colors. Choose from a variety of wood species, interior finishes, hardware, grille options, VeriLock® sensors and more. The only options not available on coastal products are decorative glass, blinds and shades.



## StormWATCH® PROTECTION

### *Impact-Resistant Insulated Glass Options\**

- Low-E
- SmartSun™
- Bronze or Gray
- Bronze/Bronze or Gray/Gray (meets Florida Turtle Code)

### *Impact-Resistant Monolithic Glass Options\**

- Low-E
- SmartSun™
- Bronze, Gray or Green
- Clear

\* See your local code official for building code requirements in your area.

\*\* E-Series Casement 3060 HP Impact DP+65/-75 (AAMA/WDMA/CSA 101/I.S.2/A440-08 & -11). For more information, visit [andersenwindows.com/e-series](http://andersenwindows.com/e-series).

† Double-hung windows are only available with impact-resistant monolithic bronze, gray, green and clear glass options.

# Grille Options

## Full Divided Light (Modern Divided Light)

Give any window an authentic look with full divided light grilles that are permanently applied to the interior and exterior of your window with a spacer between the glass. Available in ovolo (colonial) and contemporary profiles.

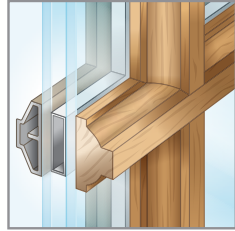

Shown with chamfer exterior grille and ovolo interior grille profiles

## Removable Interior Wood Grilles

Our removable wood grilles are installed on the interior surface. They are available with an optional surround and an optional permanently applied exterior grille. Available in ovolo and contemporary profiles.

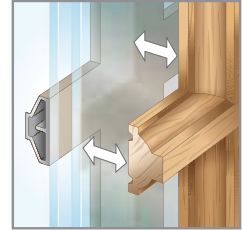

Shown with ovolo profile and optional permanently applied exterior grille with chamfer profile

## Simulated Divided Light (Classic Divided Light)

An economical solution with traditional beauty, our Simulated Divided Light features fixed exterior and interior grilles without an internal spacer. Available in ovolo and contemporary profiles.

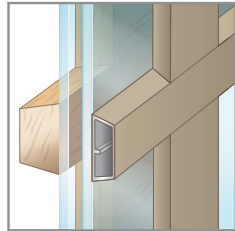

Shown with contemporary exterior and interior grille profiles

### Removable Interior Wood Grille Profiles and Widths

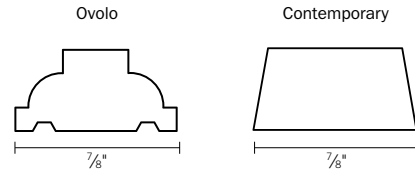

### Full and Simulated Divided Light Grille Profiles and Widths

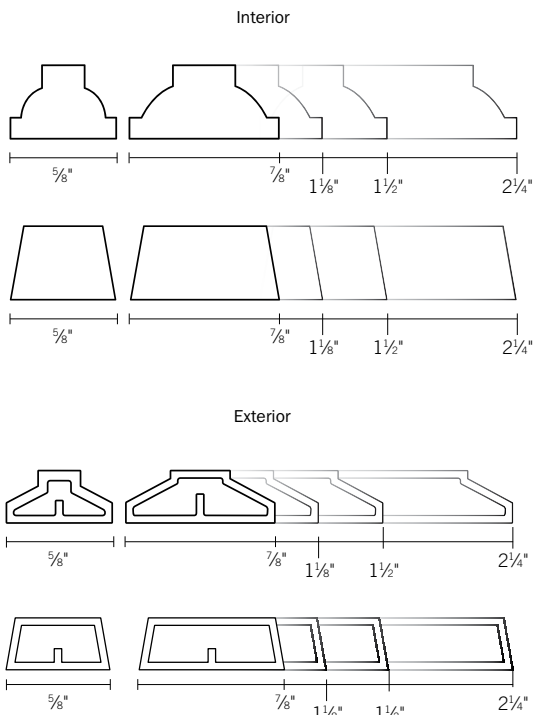

## Finelight™ Grilles-Between-the-Glass

Aluminum grilles conveniently placed between two panes of glass make the glass easy to clean inside and out.

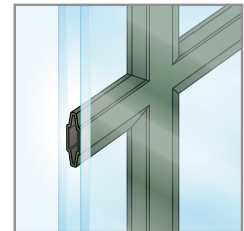

Shown with 1" contoured profile

### Finelight Grille Profiles and Widths

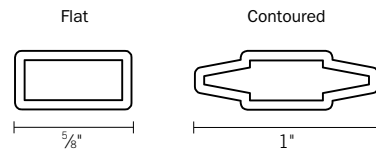

#### 5/8" Color Options

- Colony White
- Sierra Bronze
- Pebble Tan
- Forest Green

#### 1" Color Options

- Sierra Bronze/Colony White
- Pebble Tan/Colony White
- Forest Green/Colony White

Choose from our broad palette of 50 colors or select from the two-tone paint combinations shown above.



E-Series commercial doors and specialty windows with Terratone exteriors.

### Design Your Own Grilles

We offer a variety of grille patterns to choose from, or design your own with varying lines, curves and shapes to create a truly unique pattern.

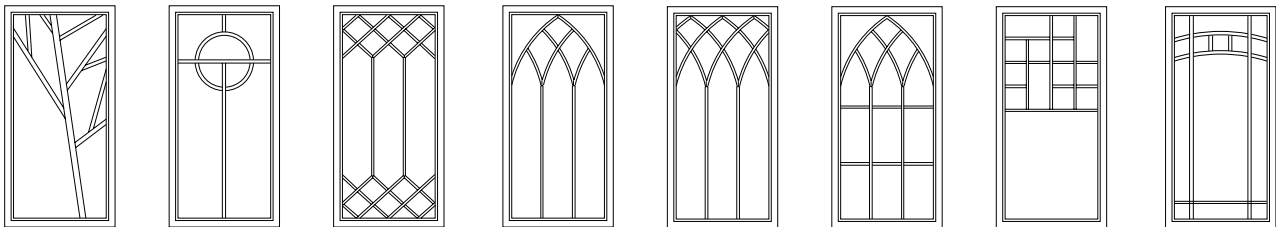

# Innovative Insect Screens

E-Series insect screens let the outside come in. We offer 50 exterior colors or optional anodized finishes for exterior insect screens. Or for beauty on the inside, add our wood-veneered options to blend seamlessly with your window.



Conventional  
Insect Screen

TruScene  
Insect Screen



Retractable  
Insect Screen

## TruScene® Insect Screen\*

TruScene window insect screens are made with a micro-fine stainless steel mesh that offers 50% more clarity than our conventional aluminum insect screens. TruScene insect screens let in more fresh air and sunlight and keep small insects out.

## Wood-Veneered Insect Screen

E-Series interior window insect screens can be veneered in one of our beautiful wood selections, allowing the frame to blend seamlessly into your window.

## Retractable Insect Screen for Patio Doors\*\*

This insect screen is built with an innovative color-matched aluminum housing that hides the insect screen when not in use. It's there when you need it and gone when you don't.

## Retractable Insect Screen for Windows

Made specifically for casement and awning windows, this wood-veneered insect screen is a sleek addition to any home. In place, the insect screen helps keep insects out. When retracted, it provides a beautiful clear view.

## Hinged Insect Screen

Available for hinged inswing patio doors, this solid insect screen offers a full-door view and features a lockable latch and automatic closer.

## Top-Hung Gliding Insect Screen for Patio Doors

Open your room to the outdoors with the touch of a finger. Our top-hung gliding insect screen provides smooth and reliable operation, season after season†

\* TruScene wood-veneered insect screens utilize a different frame profile than other E-Series wood-veneered insect screens.  
\*\* Retractable insect screens are available on inswing, outswing and gliding patio doors. See your Andersen supplier for details.

† Visit [andersenwindows.com/warranty](http://andersenwindows.com/warranty) for details.

All comparisons are made to conventional E-Series aluminum insect screens.

# Blinds & Shades

What could be more convenient than blinds or shades between the panes of glass? Minimal cleaning and no worry about damage. It's simply a fitting way to put privacy at your fingertips. E-Series blinds and shades offer the ultimate in practicality for both residential and commercial applications.

## System 3 Blinds & Shades

Add privacy and even greater energy efficiency with this low-maintenance blind or shade solution. Applied to the interior of the sash, the System 3 design creates a triple-glazed window for incredible energy efficiency. Our 5/8" blinds and pleated shades are available for casement, awning and specialty (auxiliary) windows, plus hinged patio doors, and are mounted to an extruded aluminum storm panel and applied to the interior of the sash. The removable storm panel is available in tan, gold, white or optional wood-veneer.



### Control Knobs



Bronze      White      Black      Gold

### Blind Colors



Almond      Tan      White

### Shade Colors



Almond      Pearl      Vanilla      Winter White

## Blinds-Between-the-Glass for Doors & Rectangular Specialty Windows

E-Series blinds-between-the-glass can be installed in many of our patio doors and rectangular specialty windows. Placed between the two panes of glass away from dust, dirt and damage, you get the benefit of energy efficiency and the privacy, control and convenience of blinds.



Tilt, raise and lower with one control cord\*

\* Not all sizes of blinds-between-the-glass are retractable. Printing limitations prevent exact color duplication. See your Andersen supplier for actual color samples.

# Window Hardware

Complement a home's decor with E-Series window hardware, available in a variety of finishes.

## Casement & Awning



Operator Handle & Cover

Antique Brass | Black | Bright Chrome | Bronze | Gold  
Oil Rubbed Bronze | Pewter | Polished Brass | Satin Chrome | White

## Double-Hung



Sash Lock



Sash Lift

Antique Brass | Black | Bright Chrome | Bronze | Gold  
Oil Rubbed Bronze | **Pewter** | Polished Brass | Satin Chrome | White

## Push Out Casement & Awning



Lock Handle



Insect Screen Pull

Antique Brass | Black | **Oil Rubbed Bronze**  
Polished Brass | Satin Chrome | White



Sash Lock with VeriLock® Security Sensor shown in black. See page 27 for more information.

## Gliding



Sash Lock



Slim Line Sash Pull\*

Antique Brass | **Black** | Bright Chrome | Bronze | Gold  
Oil Rubbed Bronze | Pewter | Polished Brass | Satin Chrome | White

## French Casement



Operator Handle & Cover



Sash Lock

Antique Brass | **Black** | Bright Chrome | Bronze  
Polished Brass | Satin Chrome | White

Bold name denotes finish shown.

## Hardware Finish Options

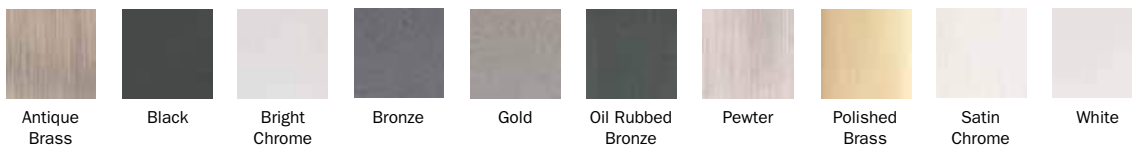

\* Sash pull available in black, bronze, gold, polished brass and white finishes.  
Hardware sold separately.

Oil rubbed bronze is a "living" finish that will change with time and use.  
Printing limitations prevent exact finish replication. See your Andersen supplier for actual finish samples.

# Smart Home Solutions

Andersen® E-Series windows and doors can now be part of today's connected home. Monitor the status of your windows and patio doors anytime and from anywhere with our sensor options.\* Plus, our new Yale® Assure Lock®, shown on page 29, lets you remotely lock or unlock your hinged patio doors.\* Learn more about the convenience and peace of mind Andersen smart home products offer at [andersenwindows.com/connect](http://andersenwindows.com/connect).



Sash Lock with VeriLock Sensor



Open/Closed Sensors

## VeriLock® Security Sensors

With the most advanced technology in the industry, VeriLock security sensors not only indicate whether windows and patio doors are open or closed, they even indicate if they are locked or unlocked.\* No other sensor can do that.

- **MAINTAINS WARRANTY**  
No drilling required which can void warranties.
- **HELPS MAXIMIZE ENERGY EFFICIENCY**  
Windows that are closed but unlocked lose air at a rate up to 3X that of a closed and locked window.\*\* VeriLock sensors tell you which windows and patio doors are open or unlocked\* so you can help manage air loss.
- **PRESERVES BEAUTY**  
Available in a variety of colors to complement many Andersen hardware or interior finishes.

## Wireless Open/Closed Sensors

These wireless sensors provide the peace of mind of knowing whether your windows and patio doors are open or closed.\*

- **EASY INSTALLATION**  
No tools are required to install our sensors. Simply place the sensor on a window or patio door and line up the magnet with the sensor until the LED glows blue†
- **MAINTAINS WARRANTY**  
No drilling required which can void warranties.
- **COMPACT DESIGN**  
Sleek, compact design in a variety of colors to blend in with the window or patio door.



\* When properly configured and maintained with a professionally installed security system and/or self-monitoring system compatible with Honeywell® 5800 controls. See your Andersen supplier for more information.

\*\* Based on testing of thirty-two (32) A-Series double-hung windows. Air loss through unlocked windows will vary based on window type and age, pressure differential, temperatures inside and outside the home, altitude and application.

† See product installation for details.

Printing limitations prevent exact color duplication. See your Andersen supplier for actual color samples.

# Patio Door Hardware

E-Series patio door hardware is available in a variety of different designs to match virtually any style. Yuma®, Encino®, Anvers®, Newbury®, Covington™ and Whitmore®, hardware options feature solid drop-forged brass for added strength, while Albany and Tribeca® hardware options are made of zinc die cast with durable powder-coated finishes.



Bold name denotes finish shown.

## Hardware Finish Options

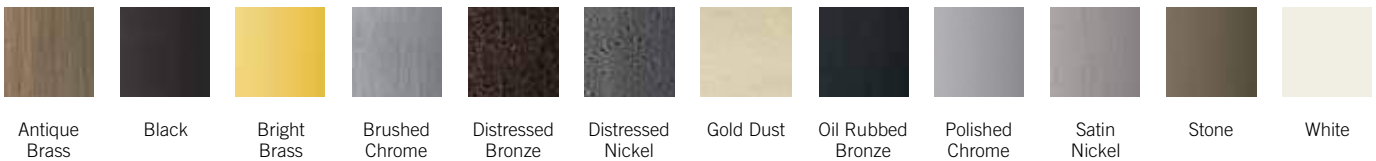

Hardware sold separately.

Distressed bronze and oil rubbed bronze are "living" finishes that will change with time and use.

Bright brass and satin nickel finishes on patio door hardware feature a 10-year limited warranty.

Printing limitations prevent exact finish replication. See your Andersen supplier for actual finish samples.



FSB® 1075 hardware.

### FSB® Hinged Patio Door Hardware

Durable, stainless steel FSB hinged door hardware features clean lines and a sleek satin finish for a thoroughly modern look.

**FSB**  
Stainless Steel



### Yale® Assure Lock®\*

Monitor, lock and unlock from anywhere with the Yale Assure Lock. The sleek, key-free lock includes Bluetooth® for keyless unlocking and is compatible with Z-Wave® for integration with a wide range of smart home platforms.

- Lock up without the hassle of keys by simply tapping the keypad.
- No cylinder means no lost keys and no pick and bump break-ins.
- Never lose power, the lock can be energized with a 9V battery.
- Verilock® security sensors, shown on page 27, know whether your doors are open, closed, locked or unlocked.\*\*
- Monitor, lock and unlock from anywhere.\*\*



Yale Assure Lock in satin nickel

\* Available on select hinged doors, see your Andersen supplier for details.  
 \*\* When properly configured and maintained with a professionally installed security system and/or self-monitoring system compatible with Honeywell® 5800 controls. See your Andersen supplier for more information.  
 Hardware sold separately.  
 Yale manufactures and supports the limited warranty for Yale Assure Lock for Andersen patio doors.  
 All marks where denoted are trademarks of their respective owners.  
 Printing limitations prevent exact finish replication. See your Andersen supplier for actual finish samples.

# Environmental Responsibility

It is more essential than ever that we all do our part to help protect the environment. While environmental responsibility may be new to some, to us, making environmentally responsible manufacturing decisions is nothing new. We've made responsible choices in the past and will continue to strive to be responsible in the future.

## Preserving Nature

To protect our natural resources, we use wood harvested from managed forests and leverage engineered wood technology whenever possible — we use finger-jointed wood and laminated veneer lumber, both of which use wood efficiently and result in superior performance. In addition, we use water-based finishes, which have less impact on the environment than oil-based products.

## Conserving Energy

Our technology and design innovation creates greater energy efficiency in all our products. Our High-Performance Low-E4® glass provides superior thermal protection, helping significantly reduce heating and cooling requirements. Additional energy-efficient glass options include triple-pane glass and SmartSun™ glass. Combined with weathertight frames, sash and weatherstrip, E-Series windows and doors play an important role in energy conservation.



High-Performance Low-E4 glass is up to 45% more energy efficient in winter and up to 57% more energy efficient in summer compared to ordinary dual-pane glass.\*

## Reducing Waste

We recycle whenever possible — office paper, corrugated cardboard, sawdust, scrap aluminum, paints and solvents. Our electrostatic paint system attracts the paint to the aluminum, creating an efficient use of materials. Packaging enhancements include frame protectors made of HDPE, a recyclable plastic.

## Taking an Active Role

We work closely with the industry organizations shown to manufacture energy-efficient and environmentally responsible products.



## Environmental Certifications

E-Series windows and doors have received SCS Global Services (SCS) Indoor Advantage™ Gold certification for indoor air quality. Indoor air quality is an important issue because many people spend as much as 90% of their time indoors, either at home, work or school.



## Using Reclaimed Materials

Our cladding contains pre-consumer reclaimed aluminum, which requires much less energy to process than virgin aluminum. In addition, our glass utilizes reclaimed glass, which reduces landfill waste.

\* Winter and summer values are based on comparison of E-Series 3866 double-hung window U-Factor to the U-Factor for clear dual-pane glass non-metal frame default values from the 2006, 2009, 2012, 2015 and 2018 International Energy Conservation Code "Glazed Fenestration" Default Tables. All marks where denoted are trademarks of their respective owners.



# Casement Windows

Simple, beautiful and extremely functional, this casement window offers enhanced energy performance. Plus, stainless steel hinges and tracks that open to 90° for great ventilation and easy cleaning. In addition, a single-lever, multi-point locking mechanism with minimally exposed hardware offers a sleek, modern look.

---

<b>Casement Overview</b> .....	<b>34</b>
<b>French Casement Overview</b> .....	<b>36</b>
<b>Push Out Casement Overview</b> .....	<b>38</b>
Sizing	
Casement .....	<b>40</b>
Casement Picture & Transom .....	<b>41</b>
Arch Casement .....	<b>42</b>
French Casement .....	<b>43</b>
Push Out Casement .....	<b>44</b>
Details .....	<b>45</b>
Installation Materials .....	<b>154</b>
Product Performance .....	<b>158</b>





E-Series casement and transom windows with black interior.

# Casement Windows

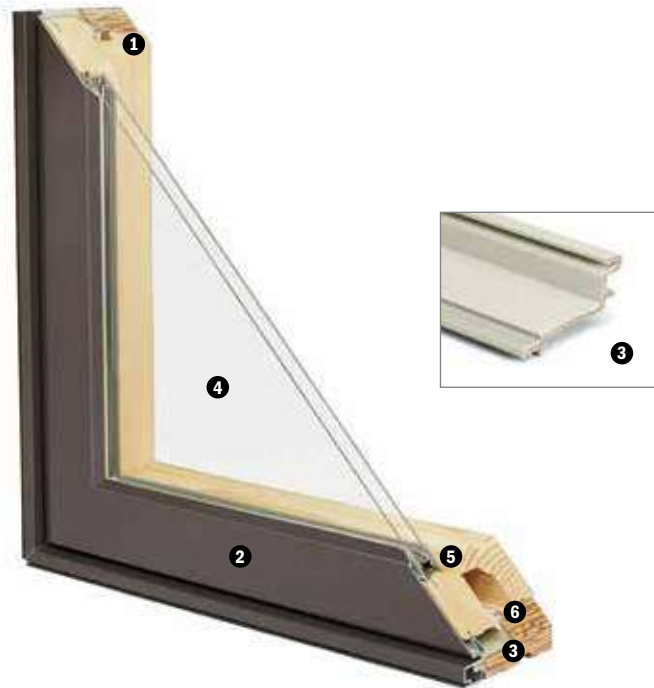

## Frame & Sash

❶ Select wood components are kiln dried and treated with water/insect repellent and preservative. Interior wood surfaces are available in pine, mixed grain Douglas fir, cherry, hickory, mahogany,\* maple, oak, walnut, alder or vertical grain Douglas fir. Interior surfaces are available unfinished or factory primed. Optional factory-applied finishes are available in a variety of stain and paint options.

❷ Wood components are fitted with aluminum extrusions on the exterior. 50 exterior colors that meet AAMA 2604 and 2605 specifications are available, as well as custom colors. Also available is a selection of seven exterior anodized options. Integral, butyl-backed corner keys provide a positive, tight seal.

❸ A Fibrex® material thermal barrier encompasses the interior perimeter of the frame and is a neutral beige color.

## Glazing

❹ High-Performance Low-E4® glass with a low-conductivity spacer. Triple-pane glass, tinted, clear dual-pane, high-altitude glass and other special glazing options are available.

❺ Glass is fixed in place from the interior with wood stops that can be removed for easy reglazing if necessary. Glass stops available in ovolo (colonial) and contemporary profiles.

## Weatherstrip

❻ A continuous perimeter bulb weatherstrip around the frame is positioned on the Fibrex material and provides a solid surface contact with the sash.

A secondary bulb weatherstrip is applied on three sides of the sash into a stand-alone kerf on the aluminum extrusion. Available in white or optional black.

## Hardware

❼ Equipped with a stainless steel gear operator, concealed hinges and hinge track. Arch casement units use stainless steel piano hinges.

Concealed sash locks (multi-point on units over 2'-8" high) provide a positive lock by operating one convenient lever. Stainless steel keepers resist corrosion.\*\*

Locks, handles and operator covers are available in 10 finishes and can be shipped separately closer to job completion.





Power operators are available in bronze, white, black or gold.

### Power Operator

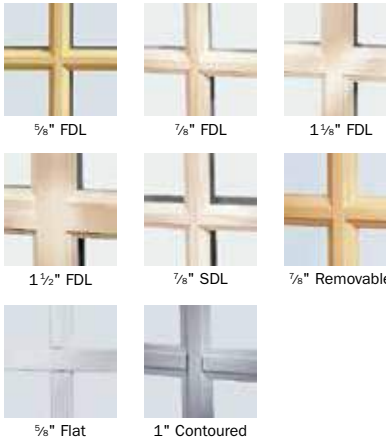

Available in bronze, white, black or gold

## Features & Options

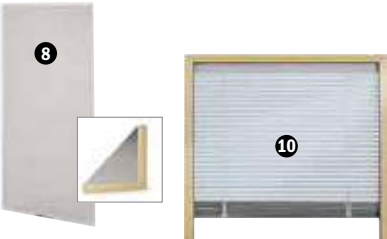
<p><b>7</b></p> <p><i>Operator Handles &amp; Covers</i></p>  <p>Bronze</p> <p>Polished Brass      Gold</p> <p>White      Black</p> <p>Antique Brass      Pewter</p> <p>Oil Rubbed Bronze      Satin Chrome</p> <p>Bright Chrome</p>	<p><b>7</b></p> <p><i>Sash Locks</i></p>  <p>Bronze      Polished Brass      Gold      White      Black</p> <p>Antique Brass      Pewter      Oil Rubbed Bronze      Satin Chrome      Bright Chrome</p>	<p><b>9</b></p> <p><i>Grilles</i></p>  <p>5/8" FDL      7/8" FDL      1 1/8" FDL</p> <p>1 1/2" FDL      7/8" SDL      7/8" Removable</p> <p>5/8" Flat      1" Contoured</p> <p>FDL = Full Divided Light* SDL = Simulated Divided Light* Removable = Removable interior wood grilles Flat = Finelight™ grilles-between-the-glass Contoured = Finelight grilles-between-the-glass</p>
<p><i>Construction Hardware</i></p> 	<p><b>8</b></p> <p><i>Insect Screens, Blinds &amp; Shades</i></p>  <p><b>10</b></p>	

An optional Window Opening Control Device Kit is available, which limits opening the sash to less than 4" when the window is first opened. Available in stone and white.

Construction locks and operator handles keep your permanent window hardware away from the construction process and possible damage yet allow operation of windows during construction.

### Window Anchorage

Vinyl installation flanges are pre-applied into a kerf on the frame exterior to facilitate installation. Optional aluminum flanges or metal installation clips are available.

### 8 Insect Screens

Charcoal fiberglass screen mesh fits into an aluminum frame in colors of bronze, white or gold as well as optional black. Aluminum screen mesh and wood-veneered insect screen also available as options.

TruScene® insect screens available in painted aluminum or wood-veneered options.

Retractable insect screen available in wood-veneered options.

See page 24 for more information on our insect screen options.

### 9 Grilles

**Full Divided Light.** Permanent interior and exterior grilles with grille spacer bars between two panes of glass. Available in 5/8", 7/8", 1 1/8", 1 1/2" or 2 1/4" widths and ovolo or contemporary profiles.

**Simulated Divided Light.** Permanent exterior and interior grilles without grille spacer bars. Available in 5/8", 7/8", 1 1/8", 1 1/2" or 2 1/4" widths and ovolo or contemporary profiles.

### Finelight™ Grilles-Between-the-Glass.

Available in 5/8" flat or 1" contoured aluminum profiles. Two-tone colors of pebble tan/colony white, sierra bronze/colony white or forest green/colony white are available on the 1" profile.

### Removable Interior Wood Grilles.

Removable interior wood grilles are

available in a 7/8" width and ovolo or contemporary profiles. Optional surround for removable grille and permanent exterior grilles also available.

### 10 Privacy Options

**System 3 Blinds.** A 5/8" aluminum slat blind is mounted to an extruded aluminum blind panel and applied to the window, creating a triple-glazed window boasting privacy and energy efficiency. Available in three colors. Blind panels are offered in white, tan, gold or an optional wood veneer to match your interior.

**System 3 Shades.** Pleated fabric shades are available in four colors to effortlessly and beautifully filter the light. See page 25 for more details.

### Sensors

VeriLock® sensors are unique as they detect whether the windows are locked or unlocked\*\* — a feature no other sensors can provide. See page 27 for Smart Home options.

\* FDL & SDL grille options also available in 2 1/4" width and in contemporary profile. See page 22 for more information.

\*\* When properly configured and maintained with a professionally installed security system and/or self monitoring system compatible with Honeywell® 5800 controls. See your Andersen supplier for more information.

Oil rubbed bronze is a "living" finish that will change with time and use.

Printing limitations prevent exact finish replication. Please see your Andersen supplier for actual finish samples.

# French Casement Windows

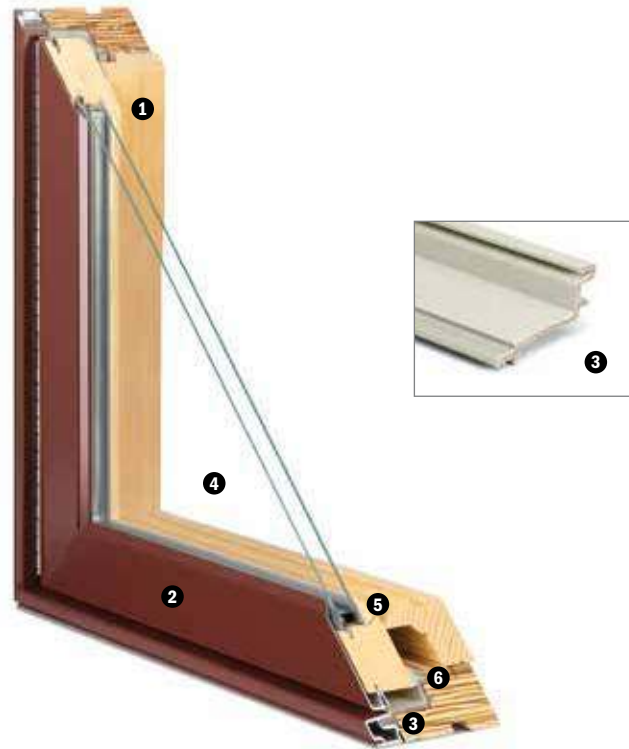

## Frame & Sash

❶ Select wood components are kiln dried and treated with water/insect repellent and preservative. Interior wood surfaces are available in pine, mixed grain Douglas fir, cherry, hickory, mahogany,\* maple, oak, walnut, alder or vertical grain Douglas fir. Interior surfaces are available unfinished or factory primed. Optional factory-applied finishes are available in a variety of stain and paint options.

❷ Wood components are fitted with aluminum extrusions on the exterior. 50 exterior colors that meet AAMA 2604 and 2605 specifications are available, as well as custom colors. Also available is a selection of seven exterior anodized options.

❸ A Fibrex® material thermal barrier encompasses the interior perimeter of the frame and is a neutral beige color.

## Glazing

❹ High-Performance Low-E4\* glass with a low-conductivity spacer. Tinted, clear dual-pane, high-altitude glass and other special glazing options are available.

❺ Glass is fixed in place from the interior with wood stops that can be removed for easy reglazing if necessary. Glass stops available in ovolo (colonial) and contemporary profiles.

## Weatherstrip

❻ A continuous perimeter bulb weatherstrip around the frame is positioned on the Fibrex material and provides a solid surface contact with the sash.

Secondary weatherstrip is applied on three sides of the sash. Available in white or optional black.

## Hardware

Equipped with stainless steel gear operators and piano hinges.

Concealed, multi-point sash locks provide a positive lock by operating one convenient lever. Stainless steel keepers resist corrosion.\*\*

Locks for French casement windows are available in bronze, white, black, polished brass, antique brass, satin chrome and bright chrome.

## Window Anchorage





Vinyl installation flanges are pre-applied into a kerf on the frame exterior to facilitate installation. Optional aluminum flanges or metal installation clips are available.

\* Actual wood species is either Sapele or Sipo, both non-endangered species grown in Africa, with color and characteristics similar to Central American mahoganies.

\*\* Visit [andersenwindows.com/warranty](http://andersenwindows.com/warranty) for details.

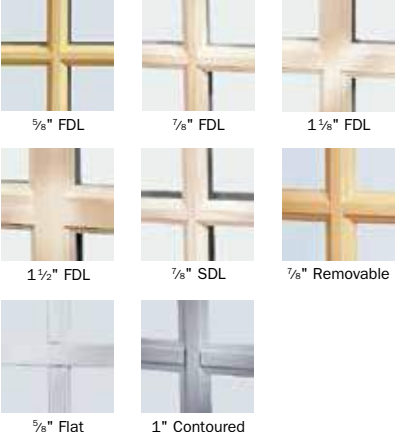

## Features & Options

7 <i>Operator Handles &amp; Covers</i>	9 <i>French Casement Locks</i>	9 <i>Grilles</i>
 <p>Bronze</p> <p>Polished Brass      Antique Brass</p> <p>White      Black</p> <p>Bright Chrome      Satin Chrome</p>	 <p>Bronze</p> <p>Polished Brass      Antique Brass</p> <p>White      Black</p> <p>Bright Chrome      Satin Chrome</p>	 <p><math>\frac{5}{8}</math>" FDL      <math>\frac{7}{8}</math>" FDL      1 <math>\frac{1}{8}</math>" FDL</p> <p>1 <math>\frac{1}{2}</math>" FDL      <math>\frac{7}{8}</math>" SDL      <math>\frac{7}{8}</math>" Removable</p> <p><math>\frac{5}{8}</math>" Flat      1" Contoured</p>
	<p>8 <i>Insect Screens</i></p> 	<p>FDL = Full Divided Light* SDL = Simulated Divided Light* Removable = Removable interior wood grilles Flat = Finelight™ grilles-between-the-glass Contoured = Finelight grilles-between-the-glass</p>

### 8 Insect Screens

Charcoal fiberglass screen mesh fits into an aluminum frame in colors of bronze, white or gold as well as optional black. Aluminum screen mesh and wood-veneered insect screen also available as options.

TruScene® insect screens available in painted aluminum or wood-veneered options.

Retractable insect screen available in wood-veneered options.

See page 24 for more information on our insect screen options.

### 9 Grilles

**Full Divided Light.** Permanent interior and exterior grilles with grille spacer bars between two panes of glass. Available in  $\frac{5}{8}$ ",  $\frac{7}{8}$ ", 1  $\frac{1}{8}$ ", 1  $\frac{1}{2}$ " or 2  $\frac{1}{4}$ " widths and ovolo or contemporary profiles.

**Simulated Divided Light.** Permanent exterior and interior grilles without grille spacer bars. Available in  $\frac{5}{8}$ ",  $\frac{7}{8}$ ", 1  $\frac{1}{8}$ ", 1  $\frac{1}{2}$ " or 2  $\frac{1}{4}$ " widths and ovolo or contemporary profiles.

**Finelight™ Grilles-Between-the-Glass.** Available in  $\frac{5}{8}$ " flat or 1" contoured aluminum profiles. Two-tone colors of pebble tan/colony white, sierra bronze/colony white or forest green/colony white are available on the 1" profile.

**Removable Interior Wood Grilles.** Removable interior wood grilles are available in a  $\frac{7}{8}$ " width and ovolo or contemporary profiles. Optional surround for removable grille and permanent exterior grilles also available.

### Sensors

VeriLock® sensors are unique as they detect whether the windows are locked or unlocked\*\* — a feature no other sensors can provide. See page 27 for Smart Home options.

\* FDL & SDL grille options also available in 2  $\frac{1}{4}$ " width and in contemporary profile. See page 22 for more information.

# Push Out Casement Windows

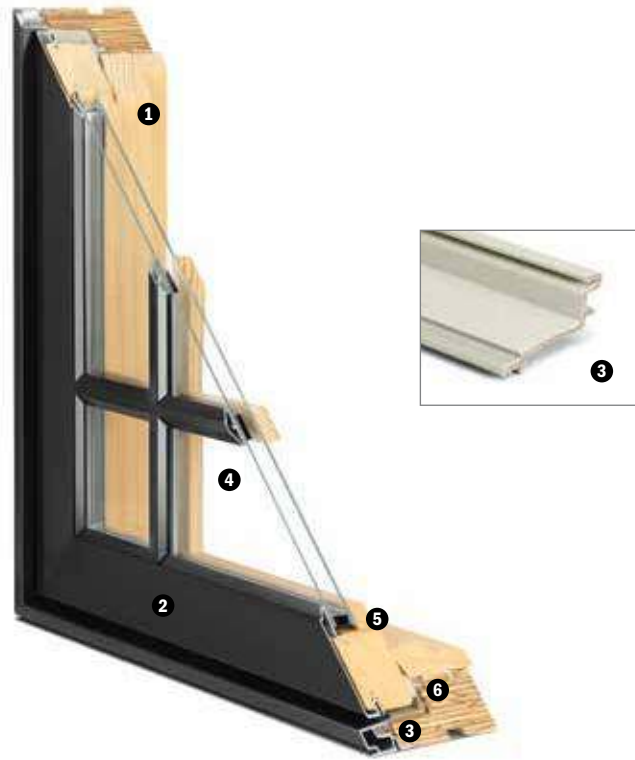

## Frame & Sash

❶ Select wood components are kiln dried and treated with water/insect repellent and preservative. Interior wood surfaces are available in pine, mixed grain Douglas fir, cherry, hickory, mahogany,\* maple, oak, walnut, alder or vertical grain Douglas fir. Interior surfaces are available unfinished or factory primed. Optional factory-applied finishes are available in a variety of stain and paint options.

❷ Wood components are fitted with aluminum extrusions on the exterior. 50 exterior colors that meet AAMA 2604 and 2605 specifications are available, as well as custom colors. Also available is a selection of seven exterior anodized options.

❸ A Fibrex® material thermal barrier encompasses the interior perimeter of the frame and is a neutral beige color.

## Glazing

❹ High-Performance Low-E4\* glass with a low-conductivity spacer. Triple-pane glass, tinted, clear dual-pane, high-altitude glass and other special glazing options are available.

❺ Glass is fixed in place from the interior with wood stops that can be removed for easy reglazing if necessary. Glass stops available in ovolo (colonial) and contemporary profiles.

## Weatherstrip

❻ A continuous perimeter bulb weatherstrip around the frame is positioned on the Fibrex material and provides a solid surface contact with the sash.

A secondary bulb weatherstrip is applied on three sides of the sash. Available in white or optional black.

## Hardware

Equipped with a stainless steel 4-bar friction hinge. Larger units use a stainless steel piano hinge with stainless steel stays.



Manual lock system featuring lock handles allows for easy operation. Units under 40" high use a single lock, while units 40" and taller use dual locks.

Lock handles are available in six finishes.

## Window Anchorage

Vinyl installation flanges are pre-applied into a kerf on the frame exterior to facilitate installation. Optional aluminum flanges or metal installation clips are available.

## Features & Options

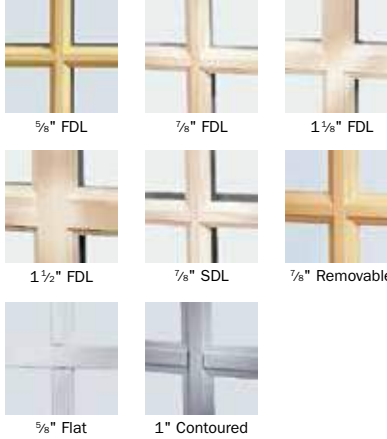
7 Lock Handles	8 Insect Screen Pulls	9 Grilles
 <p>Polished Brass</p> <p>Oil Rubbed Bronze</p> <p>Antique Brass</p> <p>Black</p> <p>White</p> <p>Satin Chrome</p>	 <p>Oil Rubbed Bronze</p> <p>Polished Brass</p> <p>Antique Brass</p> <p>Black</p> <p>White</p> <p>Satin Chrome</p> <p><i>Insect Screens</i></p> 	 <p>5/8" FDL</p> <p>7/8" FDL</p> <p>1 1/8" FDL</p> <p>1 1/2" FDL</p> <p>7/8" SDL</p> <p>7/8" Removable</p> <p>5/8" Flat</p> <p>1" Contoured</p> <p>FDL = Full Divided Light* SDL = Simulated Divided Light* Removable = Removable interior wood grilles Flat = Finelight™ grilles-between-the-glass Contoured = Finelight grilles-between-the-glass</p>

### 8 Insect Screens

Hinged insect screen opens to the interior, providing access to the lock handle. Choose from charcoal fiberglass or aluminum screen mesh. Available in wood-veneered options. Insect screen pulls are available in six finishes.

Retractable insect screen available in wood-veneered options and requires extension jambs.

See page 24 for more information on our insect screen options.

### 9 Grilles

**Full Divided Light.** Permanent interior and exterior grilles with grille spacer bars between two panes of glass. Available in 5/8", 7/8", 1 1/8", 1 1/2" or 2 1/4" widths and ovolo or contemporary profiles.

**Simulated Divided Light.** Permanent exterior and interior grilles without grille spacer bars. Available in 5/8", 7/8", 1 1/8", 1 1/2" or 2 1/4" widths and ovolo or contemporary profiles.

**Finelight™ Grilles-Between-the-Glass.** Available in 5/8" flat or 1" contoured aluminum profiles. Two-tone colors of pebble tan/colony white, sierra bronze/colony white or forest green/colony white are available on the 1" profile.

**Removable Interior Wood Grilles.** Removable interior wood grilles are available in a 7/8" width and ovolo or contemporary profiles. Optional surround for removable grille and permanent exterior grilles also available.

### Sensors

VeriLock® sensors are unique as they detect whether the windows are locked or unlocked\*\* — a feature no other sensors can provide. See page 27 for Smart Home options.

\* FDL & SDL grille options also available in 2 1/4" width and in contemporary profile. See page 22 for more information.

\*\* When properly configured and maintained with a professionally installed security system and/or self monitoring system compatible with Honeywell® 5800 controls. See your Andersen supplier for more information.

Oil rubbed bronze is a "living" finish that will change with time and use.

Printing limitations prevent exact finish replication. Please see your Andersen supplier for actual finish samples.

# Casement Window Sizes

	1' 6 1/4"	1' 8 1/2"	2' 0 1/2"	2' 4 1/2"	2' 6 1/2"	2' 8 1/2"	3' 0 1/2"
	1' 5 3/4"	1' 8"	2' 0"	2' 4"	2' 6"	2' 8"	3' 0"
2' 0 1/2"							
2' 0"							
2' 6"							
2' 8 1/2"							
2' 8"							
3' 0 1/2"							
3' 0"							
3' 4 1/2"							
3' 4"							
3' 0 1/2"							
3' 0"							
4' 0 1/2"							
4' 0"							
4' 6 1/2"							
4' 6"							
5' 0 1/2"							
5' 0"							
5' 6 1/2"							
5' 6"							
6' 0 1/2"							
6' 0"							

## NOTES

† These units meet or exceed the following dimensions: Clear Opening Area 5.7 sq. ft., Clear Opening Width 20", Clear Opening Height 24" and 44" maximum floor to sill height (with standard 6'10-1/2" structural header height).

†† Units meet the stated dimensions above when optional hardware for widest clear opening is used.

\* A sash-limiting device is standard on 2856 and 3050 casement units. See your local code official for requirements in your area.

\*\* A piano hinge and sash limiting device is standard on 2860, 3056 and 3060 casement units.

If glass is positioned within 18" of the finished floor, safety/tempered glass may be required. Local codes may differ. Verify tempered glass requirements with your local building code official.

Use structural joining material when necessary or required by code.

The light patterns illustrated apply to rectangular removable interior wood grilles, Full Divided Light, Simulated Divided Light, Decorelle 100, 150 and 400 and Finelight™ Grilles-Between-the-Glass. All removable interior wood grilles will be installed in the units unless otherwise specified.

For a metric conversion in millimeters, multiply dimensions in inches by 25.4.

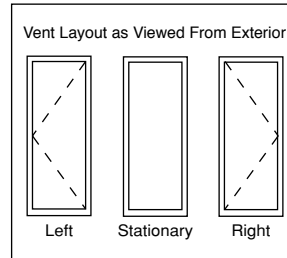

## FORMULA FOR COMBINATION WINDOWS

The overall frame dimension (both width and height) is equal to the sum of the individual unit frame dimensions plus joining material dimension(s).

The overall rough opening (both width and height) is equal to the overall frame dimensions plus 1/4" on all sides.

Any unit within each combination can be operating or stationary.

Single Unit Frame Width	2-Wide		3-Wide		4-Wide		5-Wide	
	Rough Opening Width	Frame Width	Rough Opening Width	Frame Width	Rough Opening Width	Frame Width	Rough Opening Width	Frame Width
1'-5 3/4"	3'-0"	2'-11 1/2"	4'-5 3/4"	4'-5 1/4"	5'-11 1/2"	5'-11"	7'-5 1/4"	7'-4 3/4"
1'-8"	3'-4 1/2"	3'-4"	5'-0 1/2"	5'-0"	6'-8 1/2"	6'-8"	8'-4 1/2"	8'-4"
2'-0"	4'-0 1/2"	4'-0"	6'-0 1/2"	6'-0"	8'-0 1/2"	8'-0"	10'-0 1/2"	10'-0"
2'-4"	4'-8 1/2"	4'-8"	7'-0 1/2"	7'-0"	9'-4 1/2"	9'-4"	11'-8 1/2"	11'-8"
2'-6"	5'-0 1/2"	5'-0"	7'-6 1/2"	7'-6"	10'-0 1/2"	10'-0"	12'-6 1/2"	12'-6"
2'-8"	5'-4 1/2"	5'-4"	8'-0 1/2"	8'-0"	10'-8 1/2"	10'-8"	13'-4 1/2"	13'-4"
3'-0"	6'-0 1/2"	6'-0"	9'-0 1/2"	9'-0"	12'-0 1/2"	12'-0"	15'-0 1/2"	15'-0"

### Casement Picture Window Sizes

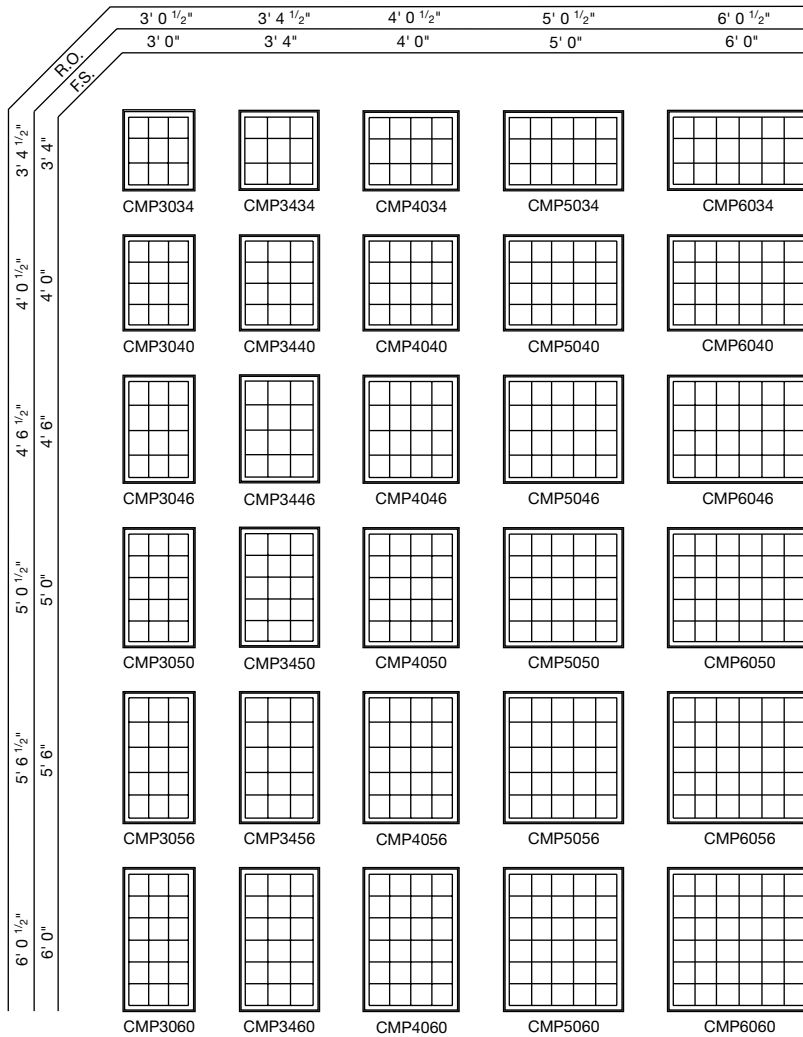

**NOTES**

If glass is positioned within 18" of the finished floor, safety/tempered glass may be required. Local codes may differ. Verify tempered glass requirements with your local building code official.

Use structural joining material when necessary or required by code.

The light patterns illustrated apply to rectangular removable interior wood grilles, Full Divided Light, Simulated Divided Light, Decorelle 100, 150 and 400 and Fineight™ Grilles-Between-the-Glass. All removable interior wood grilles will be installed in the units unless otherwise specified.

For a metric conversion in millimeters, multiply dimensions in inches by 25.4.

**FORMULA FOR COMBINATION WINDOWS**

The overall frame dimension (both width and height) is equal to the sum of the individual unit frame dimensions plus joining material dimension(s).

The overall rough opening (both width and height) is equal to the overall frame dimensions plus 1/4" on all sides.

Any unit within each combination can be operating or stationary.

### Casement Transom Window Sizes

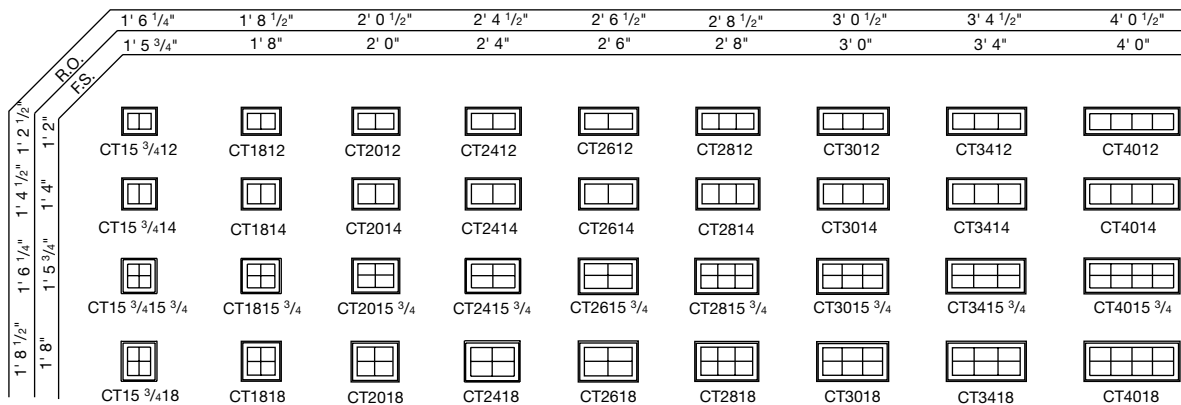

# Arch Casement Window Sizes

		2' 0 1/2"	4' 0 1/2"	2' 4 1/2"	4' 8 1/2"	2' 6 1/2"	5' 0 1/2"	2' 8 1/2"	5' 4 1/2"	3' 0 1/2"	6' 0 1/2"
		2' 0"	4' 0"	2' 4"	4' 8"	2' 6"	5' 0"	2' 8"	5' 4"	3' 0"	6' 0"
		3'-0" RAD	6'-0" RAD	3'-0" RAD	6'-0" RAD	3'-0" RAD	6'-0" RAD	3'-0" RAD	6'-0" RAD	3'-0" RAD	6'-0" RAD
R.O. F.S.	2' 0 1/2"										
	2' 0"										
	2' 6 1/2"										
	2' 6"										
	2' 8 1/2"										
	2' 8"										
	3' 0 1/2"										
	3' 0"										
	3' 4 1/2"										
	3' 4"										
4' 0 1/2"											
4' 0"											
4' 6 1/2"											
4' 6"											
5' 0 1/2"											
5' 0"											
5' 6 1/2"											
5' 6"											
6' 0 1/2"											
6' 0"											

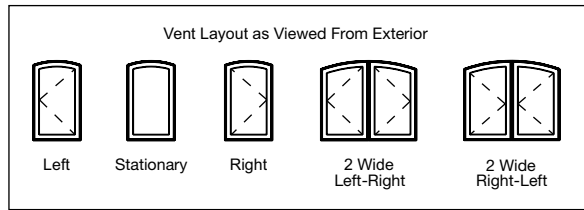

**NOTES**

† These units meet or exceed the following dimensions: Clear Opening Area 5.7 sq. ft., Clear Opening Width 20", Clear Opening Height 24" and 44" maximum floor to sill height (with standard 6'10-1/2" structural header height).

\* A sash-limiting device is standard on 2856, 2860, 3056 and 3060 casement units. See your local code official for requirements in your area.

Piano hinges are standard on all arch casement units.

See notes on page 43 for more information.

## French Casement Window Sizes

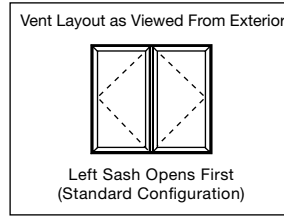
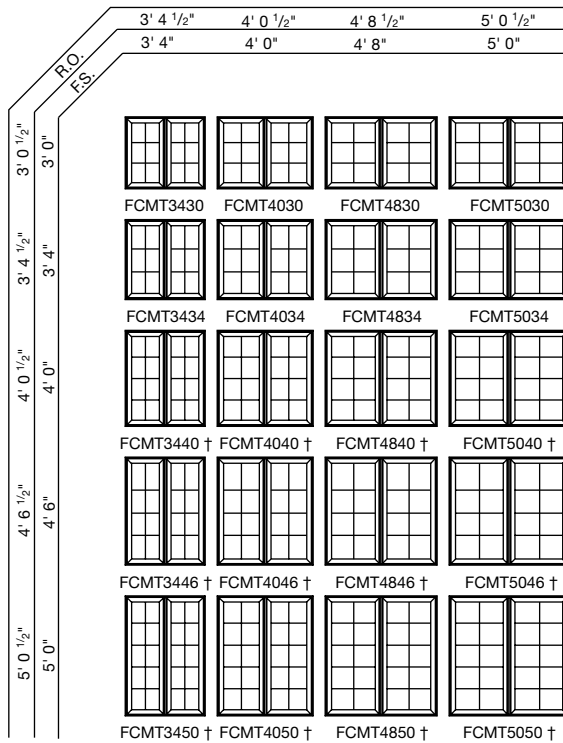

### NOTES

† These units meet or exceed the following dimensions: Clear Opening Area 5.7 sq. ft., Clear Opening Width 20", Clear Opening Height 24" and 44" maximum floor to sill height (with standard 6'10-1/2" structural header height). Local codes may differ. Verify egress requirements with your local building code official.

Piano hinges and step jamb are standard on all French casement units.

If glass is positioned within 18" of the finished floor, safety/tempered glass may be required. Local codes may differ. Verify tempered glass requirements with your local building code official.

Use structural joining material when necessary or required by code.

The light patterns illustrated apply to rectangular removable interior wood grilles, Full Divided Light, Simulated Divided Light, Decorelle 100, 150 and 400 and Finelight™ Grilles-Between-the-Glass. All removable interior wood grilles will be installed in the units unless otherwise specified.

For a metric conversion in millimeters, multiply dimensions in inches by 25.4.

### FORMULA FOR COMBINATION WINDOWS

The overall frame dimension (both width and height) is equal to the sum of the individual unit frame dimensions plus joining material dimension(s).

The overall rough opening (both width and height) is equal to the overall frame dimensions plus 1/4" on all sides.

Any unit within each combination can be operating or stationary.

# Push Out Casement Window Sizes

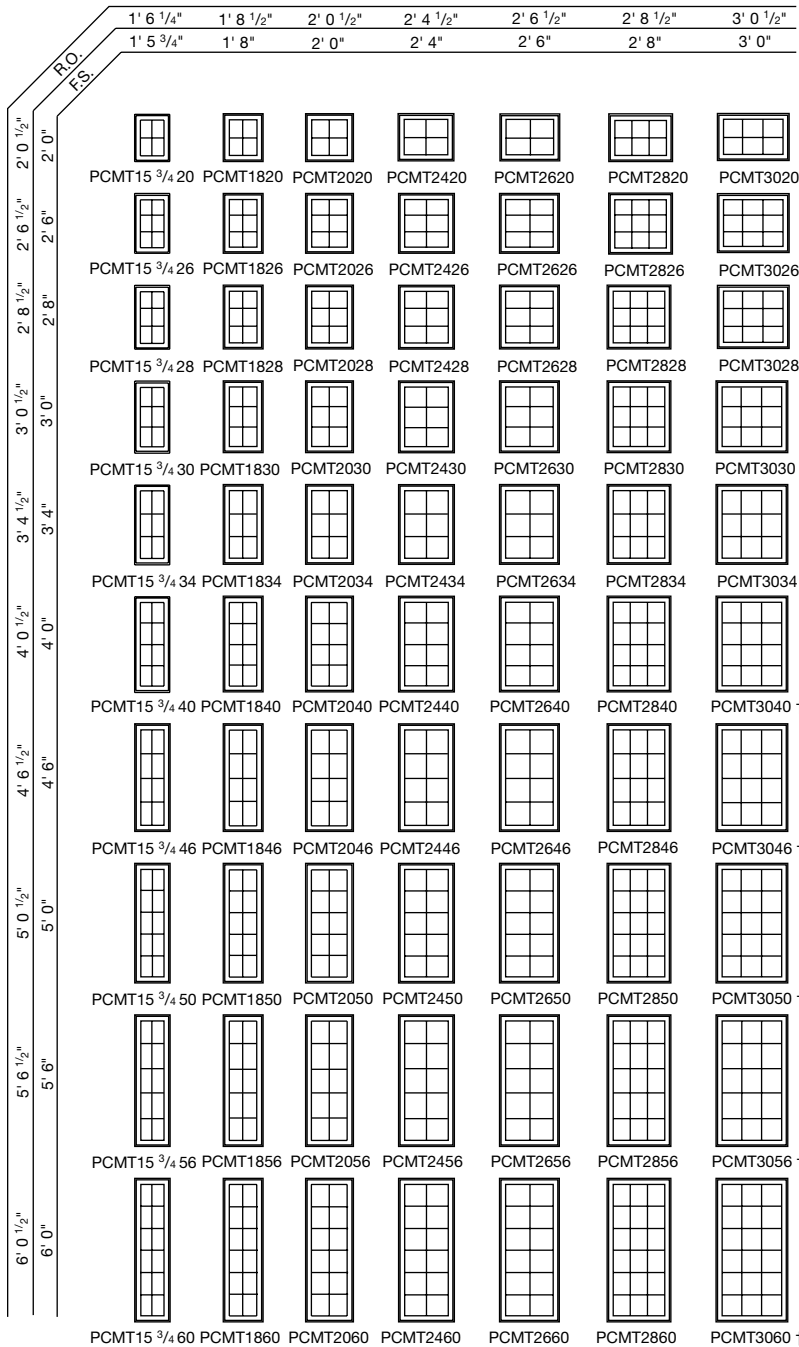

### NOTES

† These units meet or exceed the following dimensions: Clear Opening Area 5.7 sq. ft., Clear Opening Width 20", Clear Opening Height 24" and 44" maximum floor to sill height (with standard 6'10-1/2" structural header height). Local codes may differ. Verify egress requirements with your local building code official.

Units ≤ 24" Actual Frame Width (AFW) will receive hinges only (no clip or friction arm).  
 Units > 24" AFW and ≤ 30" AFW receive clip only.  
 Units > 30" AFW receive (2) 14" friction arms.

If glass is positioned within 18" of the finished floor, safety/tempered glass may be required. Local codes may differ. Verify tempered glass requirements with your local building code official.

Use structural joining material when necessary or required by code.

The light patterns illustrated apply to rectangular removable interior wood grilles, Full Divided Light, Simulated Divided Light, Decorelle 100, 150 and 400 and Finelight™ Grilles-Between-the-Glass. All removable interior wood grilles will be installed in the units unless otherwise specified.

For a metric conversion in millimeters, multiply dimensions in inches by 25.4.

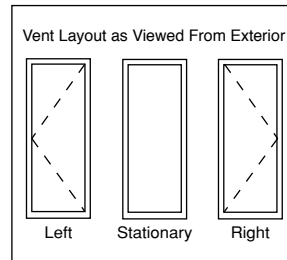

### FORMULA FOR COMBINATION WINDOWS

The overall frame dimension (both width and height) is equal to the sum of the individual unit frame dimensions plus joining material dimension(s).

The overall rough opening (both width and height) is equal to the overall frame dimensions plus 1/4" on all sides.

Any unit within each combination can be operating or stationary.

Joined Casement Combinations	2-Wide		3-Wide		4-Wide		5-Wide	
	Rough Opening Width	Frame Width	Rough Opening Width	Frame Width	Rough Opening Width	Frame Width	Rough Opening Width	Frame Width
Single Unit Frame Width								
1'-5 3/4"	3'-0"	2'-11 1/2"	4'-5 3/4"	4'-5 1/4"	5'-11 1/2"	5'-11"	7'-5 1/4"	7'-4 3/4"
1'-8"	3'-4 1/2"	3'-4"	5'-0 1/2"	5'-0"	6'-8 1/2"	6'-8"	8'-4 1/2"	8'-4"
2'-0"	4'-0 1/2"	4'-0"	6'-0 1/2"	6'-0"	8'-0 1/2"	8'-0"	10'-0 1/2"	10'-0"
2'-4"	4'-8 1/2"	4'-8"	7'-0 1/2"	7'-0"	9'-4 1/2"	9'-4"	11'-8 1/2"	11'-8"
2'-6"	5'-0 1/2"	5'-0"	7'-6 1/2"	7'-6"	10'-0 1/2"	10'-0"	12'-6 1/2"	12'-6"
2'-8"	5'-4 1/2"	5'-4"	8'-0 1/2"	8'-0"	10'-8 1/2"	10'-8"	13'-4 1/2"	13'-4"
3'-0"	6'-0 1/2"	6'-0"	9'-0 1/2"	9'-0"	12'-0 1/2"	12'-0"	15'-0 1/2"	15'-0"



Casement Windows

Casement

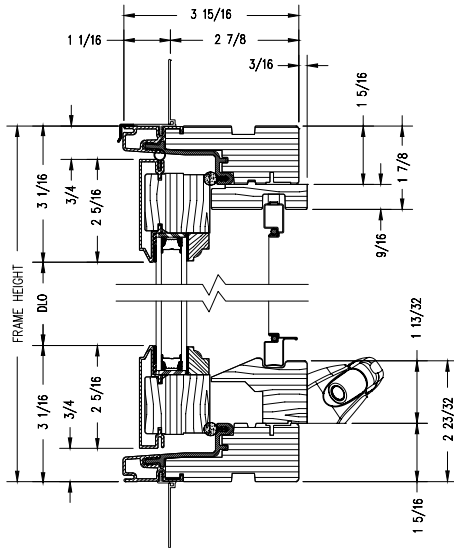

Vertical Section

Sash-Set (2-Piece) Casement

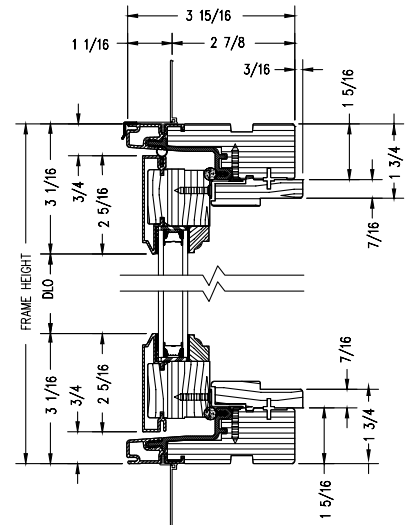

Vertical Section

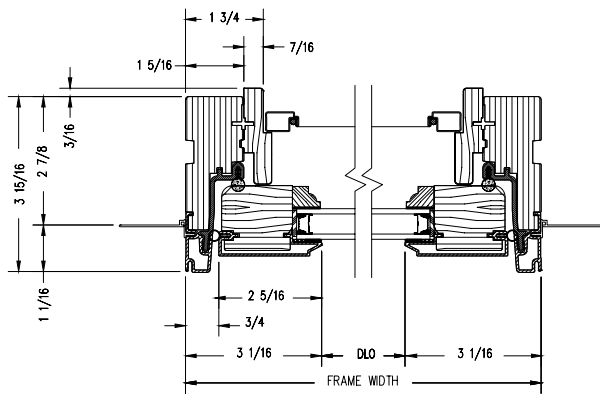

Horizontal Section

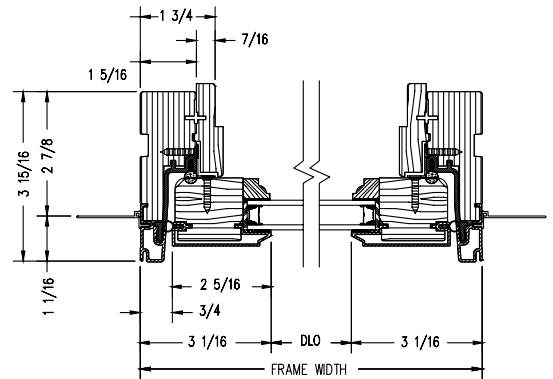

Horizontal Section

Shown with ovolo (colonial) glass stops.



## French Casement Windows

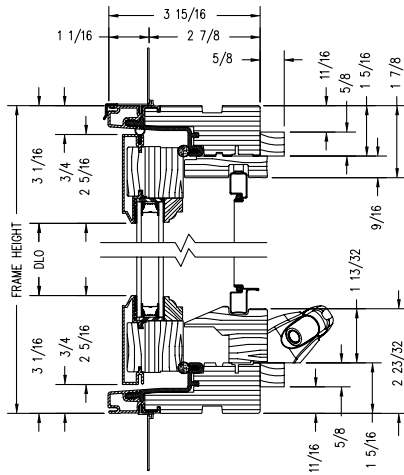

Vertical Section

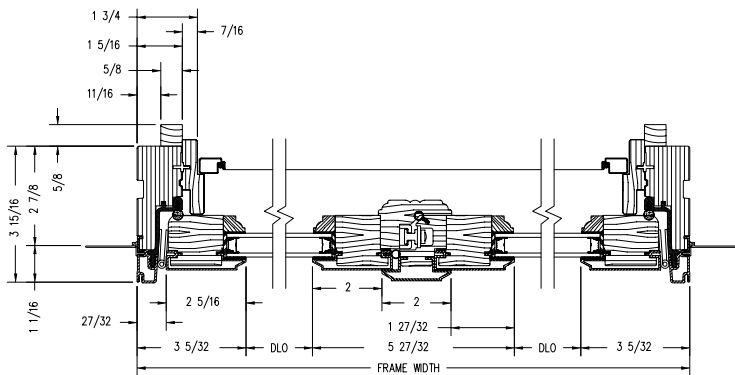

Horizontal Section

Shown with ovolo (colonial) glass stops.

## Push Out Casement Windows

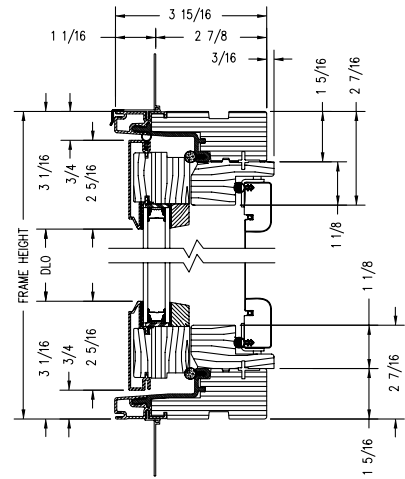

Vertical Section

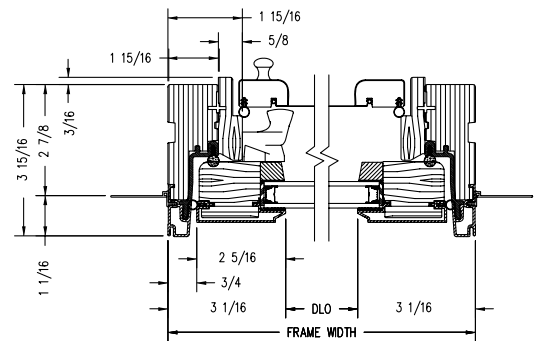

Horizontal Section

Shown with contemporary glass stops.

# Awning Windows

Used alone or as an accent window, E-Series awning windows add visual interest and ventilation. Plus they are easy to clean from the inside, while still offering a weathertight seal for outstanding performance. They include stainless steel hardware with the operator located on the sill for a true awning style and feature the same sight lines as our casement window for design flexibility when creating large window combinations.

---

<b>Awning Overview .....</b>	<b>50</b>
<b>Push Out Awning Overview .....</b>	<b>52</b>
Sizing	
Awning .....	54
Push Out Awning .....	54
Details .....	55
Installation Materials .....	154
Product Performance .....	158





E-Series awning and trapezoid windows with custom exterior finish.

# Awning Windows

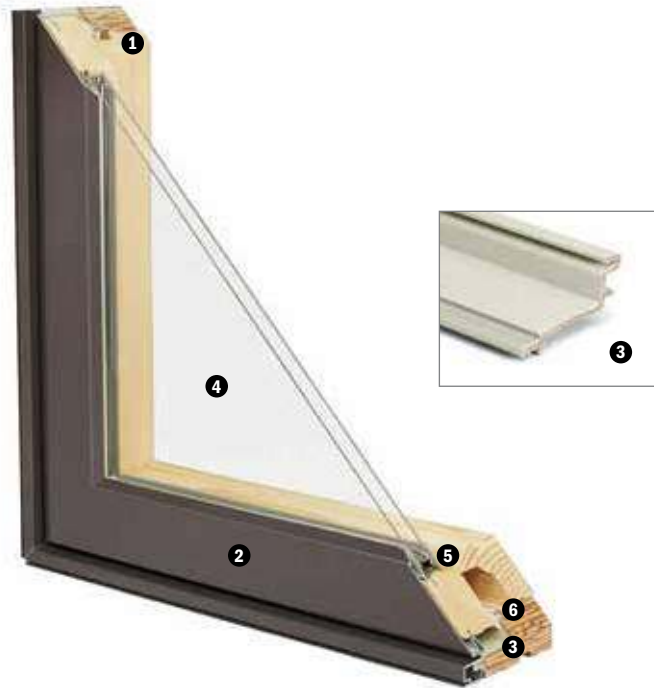

## Frame & Sash

❶ Select wood components are kiln dried and treated with water/insect repellent and preservative. Interior wood surfaces are available in pine, mixed grain Douglas fir, cherry, hickory, mahogany,\* maple, oak, walnut, alder or vertical grain douglas fir. Interior surfaces are available unfinished or factory primed. Optional factory-applied finishes are available in a variety of stain and paint options.

❷ Wood components are fitted with aluminum extrusions on the exterior. 50 exterior colors that meet AAMA 2604 and 2605 specifications are available, as well as custom colors. Also available is a selection of seven exterior anodized options. Integral, butyl-backed corner keys provide a positive, tight seal.

❸ A Fibrex® material thermal barrier encompasses the interior perimeter of the frame and is a neutral beige color.

## Glazing

❹ High-Performance Low-E4<sup>+</sup> glass with a low-conductivity spacer. Triple-pane glass, tinted, clear dual-pane, high-altitude glass and other special glazing options are available.

❺ Glass is fixed in place from the interior with wood stops that can be removed for easy reglazing if necessary. Glass stops available in ovolo (colonial) and contemporary profiles.

## Weatherstrip

❻ A continuous perimeter bulb weatherstrip around the frame is positioned on the Fibrex material and provides a solid surface contact with the sash.

A secondary bulb weatherstrip is applied on three sides of the sash into a stand-alone kerf on the aluminum extrusion. Available in white or optional black.

## Hardware

❼ Equipped with a stainless steel gear operator, concealed hinges and hinge track.

Concealed sash locks provide a positive lock. Stainless steel keepers resist corrosion.\*\*

Locks, handles and operator covers are available in 10 finishes and can be shipped separately closer to job completion.



Power operators are available in bronze, white, black or gold.

## Power Operator

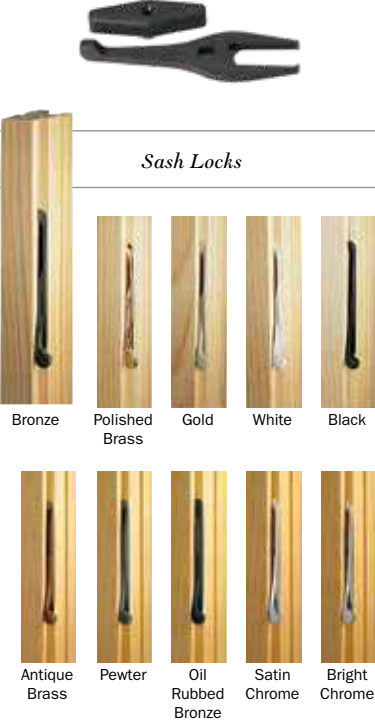

Available in bronze, white, black or gold

## Features & Options

Operator Handles & Covers	Construction Hardware	Insect Screens, Blinds & Shades
 <p>Bronze</p> <p>Polished Brass      Gold</p> <p>White      Black</p> <p>Antique Brass      Pewter</p> <p>Oil Rubbed Bronze      Satin Chrome</p> <p>Bright Chrome</p>	 <p>Sash Locks</p> <p>Bronze      Polished Brass      Gold      White      Black</p> <p>Antique Brass      Pewter      Oil Rubbed Bronze      Satin Chrome      Bright Chrome</p>	 <p>8      10</p> <p>9</p> <p>Grilles</p> <p>5/8" FDL      7/8" FDL      1 1/8" FDL</p> <p>1 1/2" FDL      7/8" SDL      7/8" Removable</p> <p>5/8" Flat      1" Contoured</p> <p>FDL = Full Divided Light* SDL = Simulated Divided Light* Removable = Removable interior wood grilles Flat = Finelight™ grilles-between-the-glass Contoured = Finelight grilles-between-the-glass</p>

Construction locks and operator handles keep your permanent window hardware away from the construction process and possible damage yet allow operation of windows during construction.

### Window Anchorage

Vinyl installation flanges are pre-applied into a kerf on the frame exterior to facilitate installation. Optional aluminum flanges or metal installation clips are available.

### 8 Insect Screens

Charcoal fiberglass screen mesh fits into an aluminum frame in colors of bronze, white or gold as well as optional black. Aluminum screen mesh and wood-veneered insect screen also available as options.

TruScene® insect screens available in painted aluminum or wood-veneered options.

Retractable insect screen available in wood-veneered options. See page 24 for

more information on our insect screen options.

### 9 Grilles

**Full Divided Light.** Permanent interior and exterior grilles with grille spacer bars between two panes of glass. Available in 5/8", 7/8", 1 1/8", 1 1/2" or 2 1/4" widths and ovolo or contemporary profiles.

**Simulated Divided Light.** Permanent exterior and interior grilles without grille spacer bars. Available in 5/8", 7/8", 1 1/8", 1 1/2" or 2 1/4" widths and ovolo or contemporary profiles.

**Finelight™ Grilles-Between-the-Glass.** Available in 5/8" flat or 1" contoured aluminum profiles. Two-tone colors of pebble tan/colony white, sierra bronze/colony white or forest green/colony white are available on the 1" profile.

**Removable interior wood grilles.** Removable interior wood grilles are available in a 7/8" width and ovolo or

contemporary profiles. Optional surround for removable grille and permanent exterior grilles also available.

### 10 Privacy Options

**System 3 Blinds.** A 5/8" aluminum slat blind is mounted to an extruded aluminum blind panel and applied to the window, creating a triple-glazed window boasting privacy and energy efficiency. Available in three colors. Blind panels are offered in white, tan, gold or an optional wood veneer to match your interior.

**System 3 Shades.** Pleated fabric shades are available in four colors to effortlessly and beautifully filter the light. See page 25 for more details.

### Sensors

VeriLock® sensors are unique as they detect whether the windows are locked or unlocked\*\* — a feature no other sensors can provide. See page 27 for Smart Home options.

\* FDL & SDL grille options also available in 2 1/4" width and in contemporary profile. See page 22 for more information.

\*\* When properly configured and maintained with a professionally installed security system and/or self monitoring system compatible with Honeywell® 5800 controls. See your Andersen supplier for more information.

Oil rubbed bronze is a "living" finish that will change with time and use.

Printing limitations prevent exact finish replication. Please see your Andersen supplier for actual finish samples.

# Push Out Awning Windows

---



---

## Frame & Sash

❶ Select wood components are kiln dried and treated with water/insect repellent and preservative. Interior wood surfaces are available in pine, mixed grain douglas fir, cherry, hickory, mahogany,\* maple, oak, walnut, alder or vertical grain Douglas fir. Interior surfaces are available unfinished or factory primed. Optional factory-applied finishes are available in a variety of stain and paint options.

❷ Wood components are fitted with aluminum extrusions on the exterior. 50 exterior colors that meet AAMA 2604 and 2605 specifications are available, as well as custom colors. Also available is a selection of seven exterior anodized options.

❸ A Fibrex® material thermal barrier encompasses the interior perimeter of the frame and is a neutral beige color.

## Glazing

❹ High-Performance Low-E4\* glass with a low-conductivity spacer. Triple-pane glass, tinted, clear dual-pane, high-altitude glass and other special glazing options are available.

❺ Glass is fixed in place from the interior with wood stops that can be removed for easy reglazing if necessary. Glass stops available in ovolo (colonial) and contemporary profiles.

## Weatherstrip



❻ A continuous perimeter bulb weatherstrip around the frame is positioned on the Fibrex material and provides a solid surface contact with the sash.

A secondary bulb weatherstrip is applied on three sides of the sash. Available in white or optional black.

## Window Anchorage

Vinyl installation flanges are pre-applied into a kerf on the frame exterior to facilitate installation. Optional aluminum flanges or metal installation clips are available.

## Features & Options

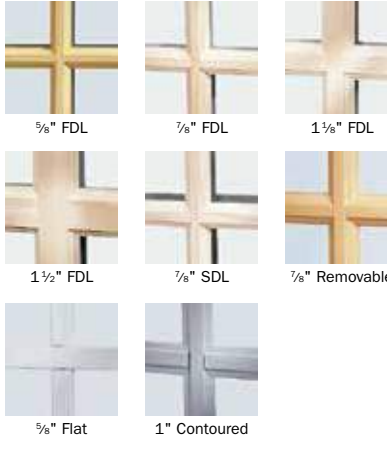
7 Lock Handles	8 Insect Screen Pulls	9 Grilles
 <p>Polished Brass</p> <p>Oil Rubbed Bronze</p> <p>Antique Brass</p> <p>White</p> <p>Black</p> <p>Satin Chrome</p>	 <p>Oil Rubbed Bronze</p> <p>Polished Brass</p> <p>Antique Brass</p> <p>Black</p> <p>White</p> <p>Satin Chrome</p> <p><i>Insect Screens</i></p> 	 <p>5/8" FDL</p> <p>7/8" FDL</p> <p>1 1/8" FDL</p> <p>1 1/2" FDL</p> <p>7/8" SDL</p> <p>7/8" Removable</p> <p>5/8" Flat</p> <p>1" Contoured</p> <p>FDL = Full Divided Light*            SDL = Simulated Divided Light*            Removable = Removable interior wood grilles            Flat = Finelight™ grilles-between-the-glass            Contoured = Finelight grilles-between-the-glass</p>

E-Series  
Awning Windows

### Hardware

**7** Equipped with a stainless steel 4-bar friction hinge.

Manual lock system featuring lock handles allows for easy operation. Units under 40" wide use a single lock, while units 40" and wider use dual locks.

Lock handles are available in six finishes.

### 8 Insect Screens

Hinged insect screen opens to the interior, providing access to the lock handle. Choose from charcoal fiberglass or aluminum screen mesh. Available in wood-veneered options. Insect screen pulls are available in six finishes.

Retractable insect screen available in wood-veneered options and requires extension jamb.

See page 24 for more information on our insect screen options.

### 9 Grilles

*Full Divided Light.* Permanent interior and exterior grilles with grille spacer bars between two panes of glass. Available in 5/8", 7/8", 1 1/8", 1 1/2" or 2 1/4" widths and ovolo and contemporary profiles.

*Simulated Divided Light.* Permanent exterior and interior grilles without grille spacer bars. Available in 5/8", 7/8", 1 1/8", 1 1/2" or 2 1/4" widths and ovolo or contemporary profiles.

*Finelight™ Grilles-Between-the-Glass.* Available in 5/8" flat or 1" contoured aluminum profiles. Two-tone colors of pebble tan/colony white, sierra bronze/colony white or forest green/colony white are available on the 1" profile.

### Removable interior wood grilles.

Removable interior wood grilles are available in a 7/8" width and ovolo or contemporary profiles. Optional surround for removable grille and permanent exterior grilles also available.

### Sensors

VeriLock® sensors are unique as they detect whether the windows are locked or unlocked\*\* — a feature no other sensors can provide. See page 27 for Smart Home options.

\* FDL & SDL grille options also available in 2 1/4" width and in contemporary profile. See page 22 for more information.

\*\* When properly configured and maintained with a professionally installed security system and/or self monitoring system compatible with Honeywell® 5800 controls. See your Andersen supplier for more information.

Oil rubbed bronze is a "living" finish that will change with time and use.

Printing limitations prevent exact finish replication. Please see your Andersen supplier for actual finish samples.

## Awning Window Sizes

	2' 0 1/2"	2' 4 1/2"	2' 6 1/2"	2' 8 1/2"	3' 0 1/2"	3' 4 1/2"	4' 0 1/2"
	2' 0"	2' 4"	2' 6"	2' 8"	3' 0"	3' 4"	4' 0"
1' 8"							
2' 0"							
2' 6"							
3' 0"							
3' 4"							
4' 0"							

### NOTES

If glass is positioned within 18" of the finished floor, safety/tempered glass may be required. Local codes may differ. Verify tempered glass requirements with your local building code official.

Use structural joining material when necessary or required by code.

The light patterns illustrated apply to rectangular removable interior wood grilles, Full Divided Light, Simulated Divided Light, Decorelle 100, 150 and 400 and Finelight™ Grilles-Between-the-Glass. All removable interior wood grilles will be installed in the units unless otherwise specified.

For a metric conversion in millimeters, multiply dimensions in inches by 25.4.

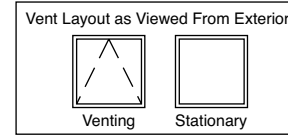

### FORMULA FOR COMBINATION WINDOWS

The overall frame dimension (both width and height) is equal to the sum of the individual unit frame dimensions plus joining material dimension(s).

The overall rough opening (both width and height) is equal to the overall frame dimensions plus 1/4" on all sides.

Any unit within each combination can be operating or stationary.

### PUSH OUT AWNING

Units ≥ 36" Actual Frame Height receive (2) friction stays.

## Push Out Awning Window Sizes

	2' 0 1/2"	2' 4 1/2"	2' 6 1/2"	2' 8 1/2"	3' 0 1/2"	3' 4 1/2"	4' 0 1/2"
	2' 0"	2' 4"	2' 6"	2' 8"	3' 0"	3' 4"	4' 0"
1' 8"							
2' 0"							
2' 6"							
3' 0"							
3' 4"							
4' 0"							

### Awning Windows

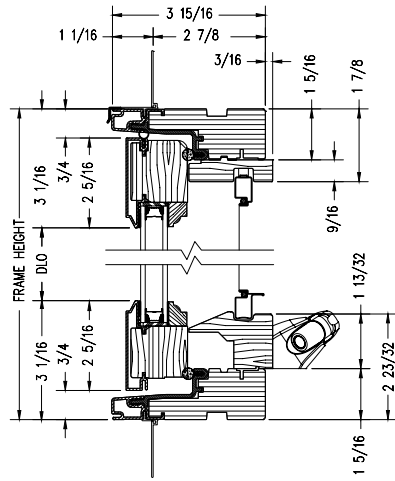

Vertical Section

### Push Out Awning Windows

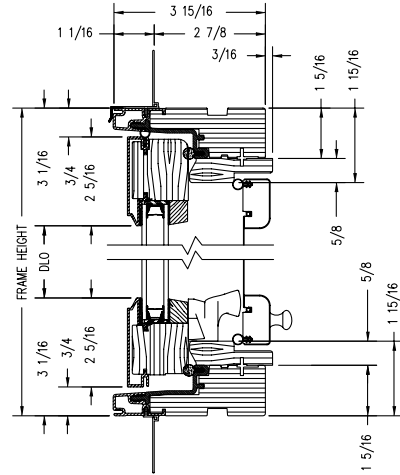

Vertical Section

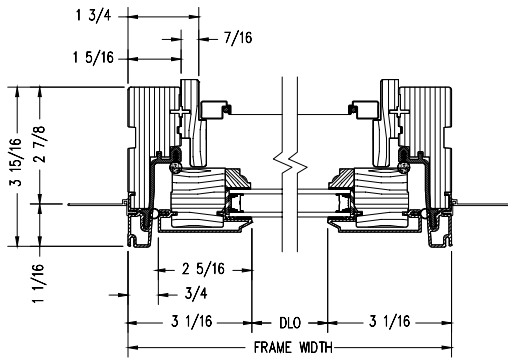

Horizontal Section

Shown with ovolo (colonial) glass stops.

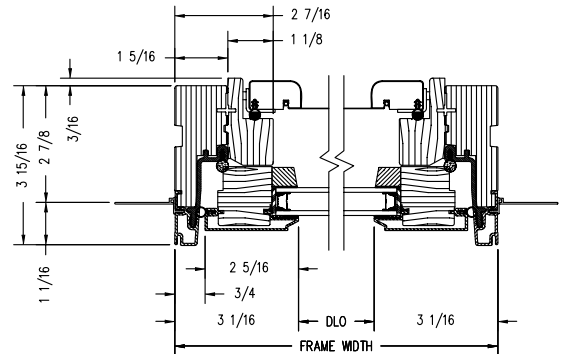

Horizontal Section

Shown with contemporary glass stops.

Joined Awning Width Combinations	2-Wide		3-Wide		
	Single Unit Frame Width	Rough Opening Width	Frame Width	Rough Opening Width	Frame Width
	2'-0"	4'-0 1/2"	4'-0"	6'-0 1/2"	6'-0"
	2'-4"	4'-8 1/2"	4'-8"	7'-0 1/2"	7'-0"
	2'-6"	5'-0 1/2"	5'-0"	7'-6 1/2"	7'-6"
	2'-8"	5'-4 1/2"	5'-4"	8'-0 1/2"	8'-0"
	3'-0"	6'-0 1/2"	6'-0"	9'-0 1/2"	9'-0"
	3'-4"	6'-8 1/2"	6'-8"	10'-0 1/2"	10'-0"
	4'-0"	8'-0 1/2"	8'-0"	12'-0 1/2"	12'-0"

Joined Awning Height Combinations	2-High		3-High		
	Single Unit Frame Height	Rough Opening Height	Frame Height	Rough Opening Height	Frame Height
	1'-8"	3'-4 1/2"	3'-4"	5'-0 1/2"	5'-0"
	2'-0"	4'-0 1/2"	4'-0"	6'-0 1/2"	6'-0"
	2'-6"	5'-0 1/2"	5'-0"	7'-6 1/2"	7'-6"
	3'-0"	6'-0 1/2"	6'-0"	9'-0 1/2"	9'-0"
	3'-4"	6'-8 1/2"	6'-8"	10'-0 1/2"	10'-0"
	4'-0"	8'-0 1/2"	8'-0"	12'-0 1/2"	12'-0"

# Double-Hung Windows

A classic beauty, double-hung windows offer a sleek design with ventilation options from the top, bottom or both. Add a TruScene® insect screen to let the outside in, maximizing your view, not limiting it. E-Series double-hung windows give you the option to select aluminum or wood jamb liner inserts for added visual appeal and include flush-mounted hardware that allows for easy tilt-in operation.

---

<b>Double-Hung Overview</b> .....	<b>58</b>
<b>Double-Hung Insert Overview</b> .....	<b>60</b>
<b>Double-Hung Sash Replacement Kit Overview</b> .....	<b>62</b>
Sizing	
Double-Hung .....	<b>64</b>
Double-Hung Cottage & Reverse Cottage .....	<b>66</b>
Double-Hung Picture & Transom .....	<b>67</b>
Arch Single-Hung .....	<b>68</b>
Arch Single-Hung Reverse Cottage .....	<b>70</b>
Direct-Set Double-Hung Transom .....	<b>71</b>
Monumental Single-Hung .....	<b>72</b>
Details .....	<b>74</b>
Installation Materials .....	<b>154</b>
Product Performance .....	<b>158</b>





E-Series double-hung windows with custom interior color.

# Double-Hung Windows

---



---

## Frame & Sash

❶ Select wood components are kiln dried and treated with water/insect repellent and preservative. Interior wood surfaces are available in pine, mixed grain douglas fir, cherry, hickory, mahogany,\* maple, oak, walnut, alder or vertical grain Douglas fir. Interior surfaces are available unfinished or factory primed. Optional factory-applied finishes are available in a variety of stain and paint options.

❷ Wood components are fitted with aluminum extrusions on the exterior. 50 exterior colors that meet AAMA 2604 and 2605 specifications are available, as well as custom colors. Also available is a selection of seven exterior anodized options.

## Glazing

❸ High-Performance Low-E4\* glass with a low-conductivity spacer. Triple-pane glass, tinted, clear dual-pane, high-altitude glass and other special glazing options are available.

❹ Glass is fixed in place from the interior with wood stops that can be removed for easy reglazing if necessary. Glass stops available in ovolo (colonial) and contemporary profiles.

## Weatherstrip

❺ Compression bulb weatherstrip is applied on the bottom sash, head jamb, at the meeting rail and on side jambs for a maximum weather seal.

## Hardware

❻ Sash lock/tilt mechanisms and keepers give a slim, more traditional design and allow opening and tilting of the window in one operation. Tilting the sash from the inside for cleaning is effortless.

Optional surface mount sash lifts allow for easy operation. Units less than 3' wide use one lift. Units 3' wide and greater use two lifts.

Hardware is available in finishes of bronze, polished brass, gold, white, black, antique brass, pewter, oil rubbed bronze, satin chrome and bright chrome.

An optional Window Opening Control Device Kit is available, which limits opening the sash to less than 4" when the window is first opened. Available in stone and white.

## Features & Options

<p><b>6</b> <i>Sash Locks</i></p>	<p><b>7</b> <i>Rigid Jamb Liners</i></p> <p>Optional Wood Insert Optional Metal Inserts</p>	<p><b>9</b> <i>Grilles</i></p>
<p><i>Sash Lifts</i></p>	<p><b>8</b> <i>Insect Screens</i></p>	<p><b>10</b> <i>VeriLock<sup>®</sup> Sensors</i></p> <p>E-Series double-hung windows with VeriLock sensors use a different sash lock. Available in all hardware finishes.</p>

### Jamb Liner & Balancer System

**7** Double-hung jamb liners incorporate synthetic interior and exterior inserts or optional painted aluminum exterior and wood-veneered interior inserts.

Jamb liners encase balancer assemblies that allow each sash to be tilted 90° inward from a bottom pivot and stay securely in place for washing.

### Window Anchorage

Optional vinyl installation flanges are pre-applied into a kerf on the frame exterior to facilitate installation. Optional aluminum flanges or metal installation clips are available.

### 8 Insect Screens

Charcoal fiberglass screen mesh fits into an aluminum frame in all 50 exterior colors and seven anodized finishes. Available in half or full insect screens. Aluminum screen mesh is available as an option.

TruScene<sup>®</sup> insect screens available in all 50 exterior colors and seven anodized finishes.

See page 24 for more information on our insect screen options.

### 9 Grilles

**Full Divided Light.** Permanent interior and exterior grilles with grille spacer bars between two panes of glass. Available in 5/8", 7/8", 1 1/8", 1 1/2" or 2 1/4" widths and ovolo or contemporary profiles.

**Simulated Divided Light.** Permanent exterior and interior grilles without grille spacer bars. Available in 5/8", 7/8", 1 1/8", 1 1/2" or 2 1/4" widths and ovolo or contemporary profiles.

**Finelight<sup>™</sup> Grilles-Between-the-Glass.** Available in 5/8" flat or 1" contoured aluminum profiles. Two-tone colors of pebble tan/colony white, sierra bronze/colony white or forest green/colony white are available on the 1" profile.

**Removable interior wood grilles.** Removable interior wood grilles are available in a 7/8" width and ovolo or contemporary profiles. Optional surround for removable grille and permanent exterior grilles also available.

### 10 Sensors

VeriLock<sup>®</sup> sensors are unique as they detect whether the windows are locked or unlocked\*\* — a feature no other sensors can provide. See page 27 for Smart Home options.

\* FDL & SDL grille options also available in 2 1/4" width and in contemporary profile. See page 22 for more information.

\*\* When properly configured and maintained with a professionally installed security system and/or self monitoring system compatible with Honeywell<sup>®</sup> 5800 controls. See your Andersen supplier for more information.

Oil rubbed bronze is a "living" finish that will change with time and use.

Printing limitations prevent exact finish replication. Please see your Andersen supplier for actual finish samples.

# Double-Hung Insert Windows

---



---

## Double-Hung Insert Windows

Double-hung insert window fits into an existing window frame making installation a breeze. The appearance of the interior and exterior of the home are maintained because the existing frame, wall coverings and trim work stay completely intact.

### Frame & Sash

❶ Select wood components are kiln dried and treated with water/insect repellent and preservative. Interior wood surfaces are available in pine, mixed grain Douglas fir, cherry, hickory, mahogany,\* maple, oak, walnut, alder or vertical grain Douglas fir. Interior surfaces are available unfinished or factory primed. Optional factory-applied finishes are available in a variety of stain and paint options.

❷ Wood components are fitted with aluminum extrusions on the exterior. 50 exterior colors that meet AAMA

2604 and 2605 specifications are available, as well as custom colors. Also available is a selection of seven exterior anodized options.

### Glazing

❸ High-Performance Low-E4® glass with a low-conductivity spacer. Triple-pane glass, tinted, clear dual-pane, high-altitude glass and other special glazing options are available.

❹ Glass is fixed in place from the interior with wood stops that can be removed for easy reglazing if necessary. Glass stops available in ovolo (colonial) and contemporary profiles.

### Weatherstrip

❺ Compression bulb weatherstrip is applied on the bottom sash, head jamb, at the meeting rail and on side jambs for a maximum weather seal.

### Hardware

❻ Sash lock/tilt mechanisms and keepers give a slim, more traditional design and allow opening and tilting of the window in one operation. Tilting the sash from the inside for cleaning is effortless.

Surface mount sash lifts are available and allow for easy operation. Units less than 3' wide use one lift. Units 3' wide and greater use two lifts.

Sash locks and lifts are available in finishes of bronze, polished brass, gold, white, black, antique brass, pewter, oil rubbed bronze, satin chrome and bright chrome.

An optional Window Opening Control Device Kit is available, which limits opening the sash to less than 4" when the window is first opened. Available in stone and white.

## Features & Options

<p><b>6</b></p> <p><i>Sash Locks</i></p>	<p><b>7</b></p> <p><i>Rigid Jamb Liners</i></p>	<p><b>9</b></p> <p><i>Grilles</i></p>
<p><i>Sash Lifts</i></p>	<p><b>8</b></p> <p><i>Insect Screens</i></p>	<p><b>10</b></p> <p><i>VeriLock® Sensors</i></p> <p>E-Series double-hung windows with VeriLock sensors use a different sash lock. Available in all hardware finishes.</p>

### Jamb Liner & Balancer System

**7** Basic jamb liners are available in beige or white and are made of synthetic material. Optional painted aluminum exterior inserts and wood-veneered interior inserts also available.

Jamb liners encase balancer assemblies that allow each sash to be tilted 90° inward from a bottom pivot and stay securely in place for washing.

### Sill Slope

8 degrees is the standard slope. Filler block is used on existing window sill angles of less than 8 degrees.

### 8 Insect Screens

Charcoal fiberglass screen mesh fits into an aluminum frame in all 50 exterior colors and seven anodized finishes. Available in half or full insect screens. Aluminum screen mesh is available as an option.

TruScene® insect screens available in all 50 exterior colors and seven anodized finishes.

See page 24 for more information on our insect screen options.

### 9 Grilles

**Full Divided Light.** Permanent interior and exterior grilles with grille spacer bars between two panes of glass. Available in 5/8", 7/8", 1 1/8", 1 1/2" or 2 1/4" widths and ovolo or contemporary profiles.

**Simulated Divided Light.** Permanent exterior and interior grilles without grille spacer bars. Available in 5/8", 7/8", 1 1/8", 1 1/2" or 2 1/4" widths and ovolo or contemporary profiles.

**Finelight™ Grilles-Between-the-Glass.** Available in 5/8" flat or 1" contoured aluminum profiles. Two-tone colors of

pebble tan/colony white, sierra bronze/colony white or forest green/colony white are available on the 1" profile.

### Removable interior wood grilles.

Removable interior wood grilles are available in a 7/8" width and ovolo or contemporary profiles. Optional surround for removable grille and permanent exterior grilles also available.

### 10 Sensors

VeriLock® sensors are unique as they detect whether the windows are locked or unlocked\*\* — a feature no other sensors can provide. See page 27 for Smart Home options.

### Measuring Guidelines

Measuring guidelines for double-hung insert and picture insert windows can be found on [andersenwindows.com/measure](http://andersenwindows.com/measure).

\* FDL & SDL grille options also available in 2 1/4" width and in contemporary profile. See page 22 for more information.

\*\* When properly configured and maintained with a professionally installed security system and/or self monitoring system compatible with Honeywell® 5800 controls. See your Andersen supplier for more information.

Oil rubbed bronze is a "living" finish that will change with time and use.

Printing limitations prevent exact finish replication. Please see your Andersen supplier for actual finish samples.

# Double-Hung Sash Replacement Kits



## Sash Replacement Kits

Double-hung sash replacement kits are complete with window sash, locking hardware and sash lifts, compression jamb liners and balancer systems, sill filler, head parting stop and installation hardware. Each kit is built to your exact measurements.

The kits were designed to replace older sash with a new energy-efficient sash without removing the trim and the window frame. The sash replacement will fit a double-hung window with a jamb pocket depth of 3 1/4" or larger.

Kits are also available in a picture window design. The sash depth is 1 17/32". Picture window sash replacement kit consists of one sash and one sill filler.

## Sash

❶ Select wood components are kiln dried and treated with water/insect repellent and preservative. Interior wood surfaces are available in pine, mixed grain douglas fir, cherry, hickory, mahogany,\* maple, oak, walnut, alder or vertical grain Douglas fir. Interior surfaces are available unfinished or factory primed. Optional factory-applied finishes are available in a variety of stain and paint options.

❷ Wood components are fitted with aluminum extrusions on the exterior. 50 exterior colors that meet AAMA 2604 and 2505 specifications are available, as well as custom colors. Also available is a selection of seven exterior anodized options.

## Glazing

❸ High-Performance Low-E4° glass with a low-conductivity spacer. Tinted, clear dual-pane, high-altitude glass and other special glazing options are available.

❹ Glass is fixed in place from the interior with wood stops that can be removed for easy reglazing if necessary. Glass stops available in ovolo (colonial) and contemporary profiles.

## Weatherstrip

❺ The sash replacement kit utilizes a foam weatherstrip on the bottom of the lower sash that forms a weather-tight seal against the sill filler when closed.

❻ Hollow bulb weatherstrip forms a compression seal at the meeting rails and at the head.



## Features & Options

7 <i>Sash Locks</i>	8 <i>Insect Screens</i>	9 <i>Grilles</i>
 <p>Bronze</p> <p>Polished Brass</p> <p>White</p> <p>Gold</p> <p>Black</p>		 <p>5/8" FDL</p> <p>7/8" FDL</p> <p>1 1/8" FDL</p> <p>1 1/2" FDL</p> <p>7/8" SDL</p> <p>7/8" Removable</p> <p>5/8" Flat</p> <p>1" Contoured</p>
<p><i>Sash Lifts</i></p>  <p>Bronze</p> <p>Polished Brass</p> <p>White</p> <p>Gold</p> <p>Black</p>		<p>FDL = Full Divided Light*</p> <p>SDL = Simulated Divided Light*</p> <p>Removable = Removable interior wood grilles</p> <p>Flat = Finelight™ grilles-between-the-glass</p> <p>Contoured = Finelight grilles-between-the-glass</p>

E-Series  
Double-Hung Windows

### Hardware

7 Sash replacement kits under 36" in width will receive one lock and one sash lift. Kits 36" to 48" in width will receive two locks and two sash lifts. Kits 48" and wider will require three locks and two sash lifts. Finishes are available in bronze, black, white, gold and polished brass.

### Jamb Liner & Balancer System

Each kit utilizes a two-piece foam-backed jamb liner and a block and tackle balancer system. The sash tilt inward for easy cleaning. Beige or white jamb liners are available and are cut to the sill slope specified at time of order.

### 8 Insect Screens

Charcoal fiberglass screen mesh fits into an aluminum frame in all 50 exterior colors and seven anodized finishes. Available in half or full insect screens. Aluminum screen mesh is available as an option.

TruScene® insect screens available in all 50 exterior colors and seven anodized finishes.

See page 24 for more information on our insect screen options.

### 9 Grilles

*Full Divided Light.* Permanent interior and exterior grilles with grille spacer bars between two panes of glass. Available in 5/8", 7/8", 1 1/8", 1 1/2" or 2 1/4" widths and ovolo or contemporary profiles.

*Simulated Divided Light.* Permanent exterior and interior grilles without grille spacer bars. Available in 5/8", 7/8", 1 1/8", 1 1/2" or 2 1/4" widths and ovolo or contemporary profiles.

*Finelight™ Grilles-Between-the-Glass.* Available in 5/8" flat or 1" contoured aluminum profiles. Two-tone colors of pebble tan/colony white, sierra bronze/colony white or forest green/colony white are available on the 1" profile.

### Removable interior wood grilles.

Removable interior wood grilles are available in a 7/8" width and ovolo or contemporary profiles. Optional surround for removable grille and permanent exterior grilles also available.

### Measuring Guidelines

Measuring guidelines for double-hung and picture sash replacement kits can be found on [andersenwindows.com/measure](http://andersenwindows.com/measure).

\* FDL & SDL grille options also available in 2 1/4" width and in contemporary profile. See page 22 for more information. Printing limitations prevent exact finish replication. Please see your Andersen supplier for actual finish samples.

# Double-Hung Window Sizes

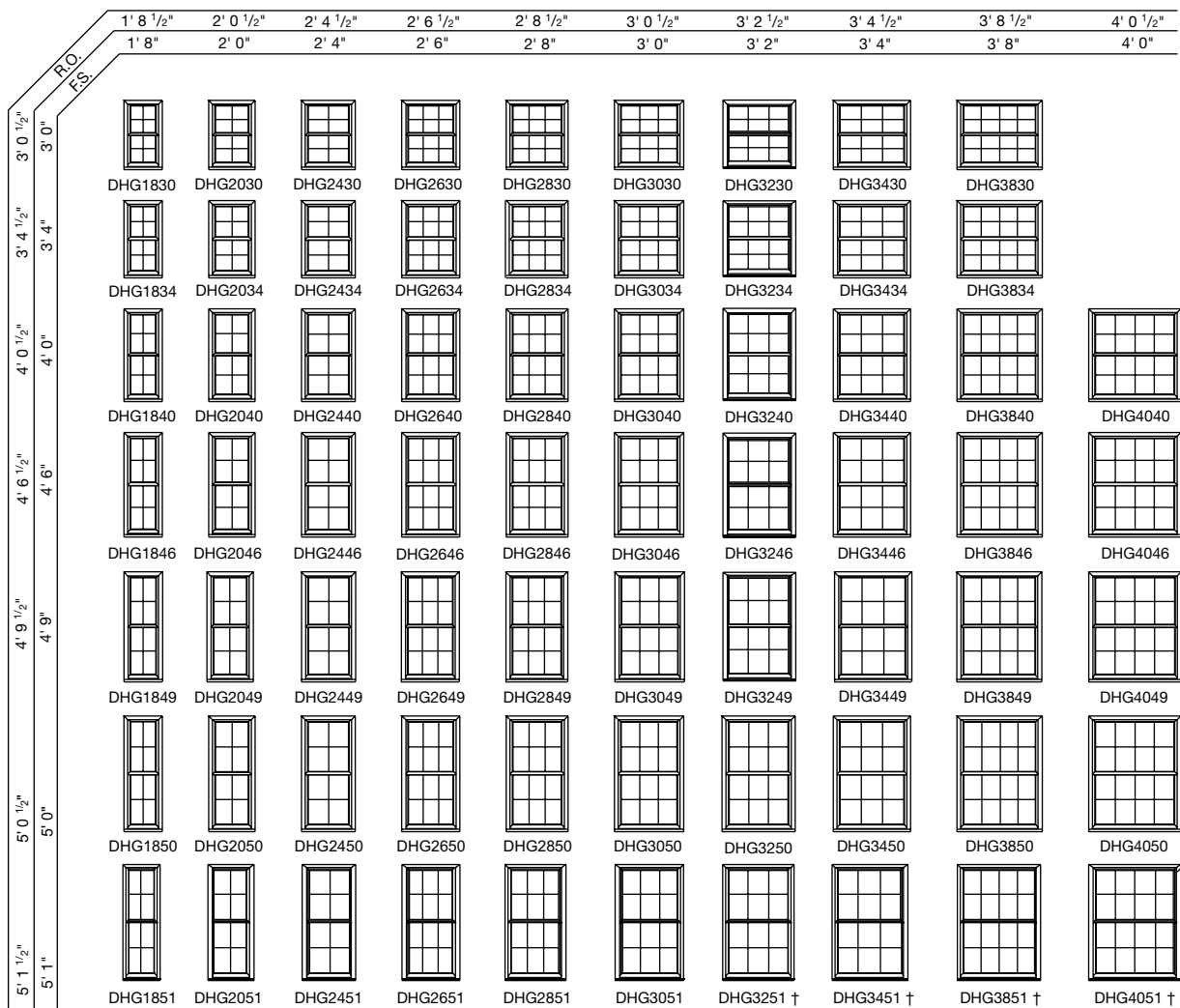

Joined Double-Hung Combinations					
2-Wide			3-Wide		
Single Unit Frame Width	Rough Opening Width	Frame Width	Single Unit Frame Width	Rough Opening Width	Frame Width
1'-8"	3'-4 1/2"	3'-4"	1'-8"	5'-0 1/2"	5'-0"
2'-0"	4'-0 1/2"	4'-0"	2'-0"	6'-0 1/2"	6'-0"
2'-4"	4'-8 1/2"	4'-8"	2'-4"	7'-0 1/2"	7'-0"
2'-6"	5'-0 1/2"	5'-0"	2'-6"	7'-6 1/2"	7'-6"
2'-8"	5'-4 1/2"	5'-4"	2'-8"	8'-0 1/2"	8'-0"
3'-0"	6'-0 1/2"	6'-0"	3'-0"	9'-0 1/2"	9'-0"
3'-2"	6'-4 1/2"	6'-4"	3'-2"	9'-6 1/2"	9'-6"
3'-4"	6'-8 1/2"	6'-8"	3'-4"	10'-0 1/2"	10'-0"
3'-8"	7'-4 1/2"	7'-4"	3'-8"	11'-0 1/2"	11'-0"
4'-0"	8'-0 1/2"	8'-0"	4'-0"	12'-0 1/2"	12'-0"

**NOTES**

† These units meet or exceed the following dimensions: Clear Opening Area 5.7 sq. ft., Clear Opening Width 20", Clear Opening Height 24" and 44" maximum floor to sill height (with standard 6'10-1/2" structural header height). See your local code official for requirements in your area.

Units may be ordered with sash lifts if desired. Units 3'0" and wider will use two sash lifts.

If glass is positioned within 18" of the finished floor, safety/tempered glass may be required. Local codes may differ. Verify tempered glass requirements with your local building code official.

Use structural joining material when necessary or required by code.

The light patterns illustrated apply to rectangular removable interior wood grilles, Full Divided Light, Simulated Divided Light, Decorelle 100, 150 and 400 and Finelight™ Grilles-Between-the-Glass. All removable interior wood grilles will be installed in the units unless otherwise specified.

For a metric conversion in millimeters, multiply dimensions in inches by 25.4.

**FORMULA FOR COMBINATION WINDOWS**

The overall frame dimension (both width and height) is equal to the sum of the individual unit frame dimensions plus joining material dimension(s).

The overall rough opening (both width and height) is equal to the overall frame dimensions plus 1/4" on all sides.

## Double-Hung Window Sizes

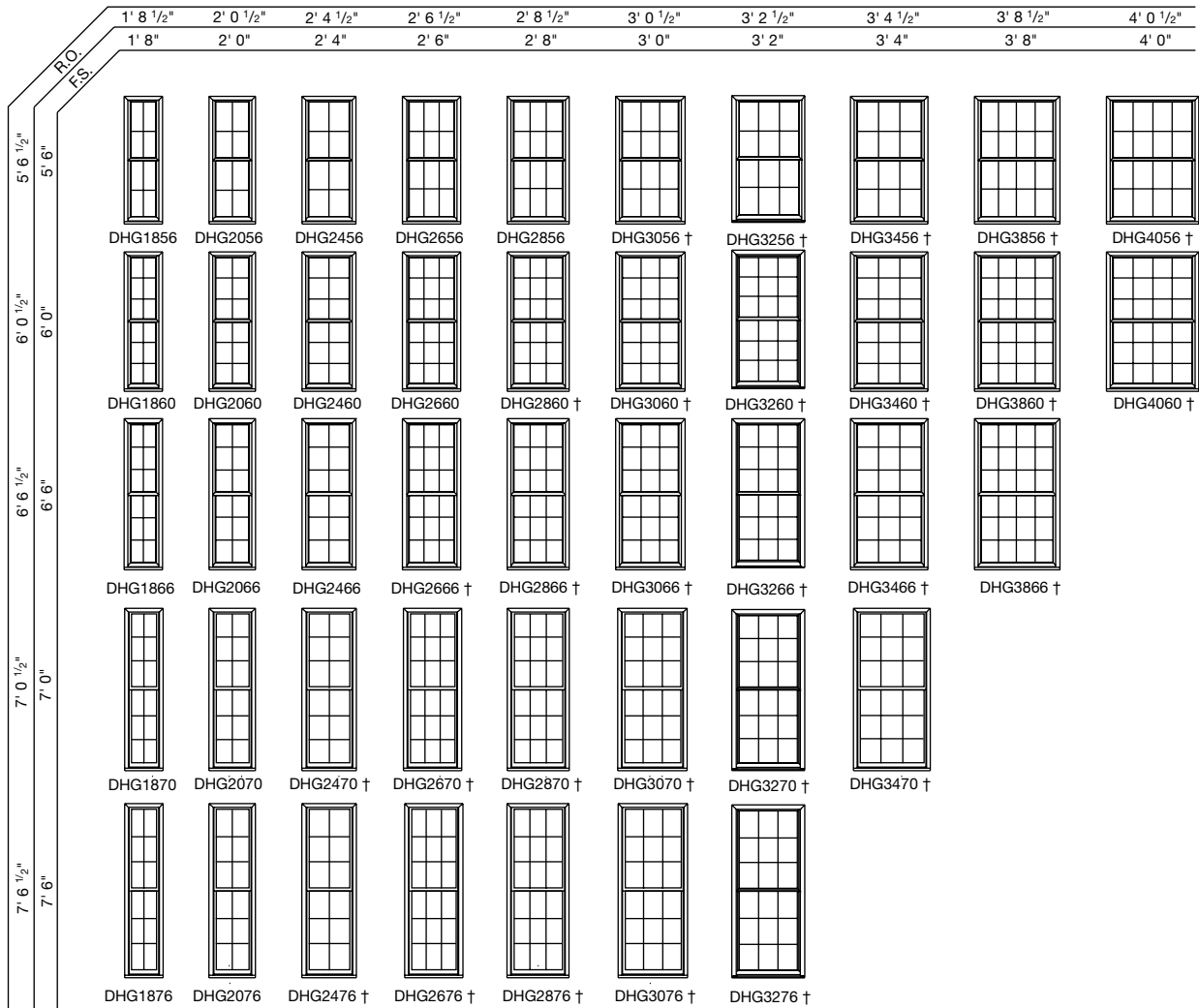

### NOTES

† These units meet or exceed the following dimensions: Clear Opening Area 5.7 sq. ft., Clear Opening Width 20", Clear Opening Height 24" and 44" maximum floor to sill height (with standard 6'10-1/2" structural header height). See your local code official for requirements in your area.

Units may be ordered with sash lifts if desired. Units 3'0" and wider will use two sash lifts.

If glass is positioned within 18" of the finished floor, safety/tempered glass may be required. Local codes may differ. Verify tempered glass requirements with your local building code official.

Use structural joining material when necessary or required by code.

The light patterns illustrated apply to rectangular removable interior wood grilles, Full Divided Light, Simulated Divided Light, Decorelle 100, 150 and 400 and Finelight™ Grilles-Between-the-Glass. All removable interior wood grilles will be installed in the units unless otherwise specified.

For a metric conversion in millimeters, multiply dimensions in inches by 25.4.

### FORMULA FOR COMBINATION WINDOWS

The overall frame dimension (both width and height) is equal to the sum of the individual unit frame dimensions plus joining material dimension(s).

The overall rough opening (both width and height) is equal to the overall frame dimensions plus 1/4" on all sides.

# Cottage & Reverse Cottage Double-Hung Window Sizes

	1' 8 1/2"	2' 0 1/2"	2' 4 1/2"	2' 6 1/2"	2' 8 1/2"	3' 0 1/2"	3' 2 1/2"	3' 4 1/2"	3' 8 1/2"
	1' 8"	2' 0"	2' 4"	2' 6"	2' 8"	3' 0"	3' 2"	3' 4"	3' 8"
4' 6 1/2"									
	DHC1846	DHC2046	DHC2446	DHC2646	DHC2846	DHC3046	DHC3246	DHC3446	DHC3846
4' 6"									
	DHRC1846	DHRC2046	DHRC2446	DHRC2646	DHRC2846	DHRC3046	DHRC3246	DHRC3446	DHRC3846
5' 0 1/2"									
	DHC1850	DHC2050	DHC2450	DHC2650	DHC2850	DHC3050	DHC3250	DHC3450	DHC3850
5' 0"									
	DHRC1850	DHRC2050	DHRC2450	DHRC2650	DHRC2850	DHRC3050	DHRC3250	DHRC3450	DHRC3850
5' 1 1/2"									
	DHC1851	DHC2051	DHC2451	DHC2651	DHC2851	DHC3051	DHC3251	DHC3451	DHC3851
5' 1"									
	DHRC1851	DHRC2051	DHRC2451	DHRC2651	DHRC2851	DHRC3051	DHRC3251	DHRC3451	DHRC3851
5' 6 1/2"									
	DHC1856	DHC2056	DHC2456	DHC2656	DHC2856	DHC3056	DHC3256	DHC3456	DHC3856
5' 6"									
	DHRC1856	DHRC2056	DHRC2456	DHRC2656	DHRC2856	DHRC3056	DHRC3256	DHRC3456	DHRC3856
6' 0 1/2"									
	DHC1860	DHC2060	DHC2460	DHC2660	DHC2860	DHC3060	DHC3260	DHC3460	DHC3860
6' 0"									
	DHRC1860	DHRC2060	DHRC2460	DHRC2660	DHRC2860	DHRC3060	DHRC3260	DHRC3460	DHRC3860

## NOTES

Units may be ordered with sash lifts if desired. Units 3'0" and wider will use two sash lifts.

If glass is positioned within 18" of the finished floor, safety/tempered glass may be required. Local codes may differ. Verify tempered glass requirements with your local building code official.

Use structural joining material when necessary or required by code.

The light patterns illustrated apply to rectangular removable interior wood grilles, Full Divided Light, Simulated Divided Light, Decorelle 100, 150 and 400 and Finelight™ Grilles-Between-the-Glass. All removable interior wood grilles will be installed in the units unless otherwise specified.

For a metric conversion in millimeters, multiply dimensions in inches by 25.4.

## FORMULA FOR COMBINATION WINDOWS

The overall frame dimension (both width and height) is equal to the sum of the individual unit frame dimensions plus joining material dimension(s).

The overall rough opening (both width and height) is equal to the overall frame dimensions plus 1/4" on all sides.

### Double-Hung Picture Window Sizes

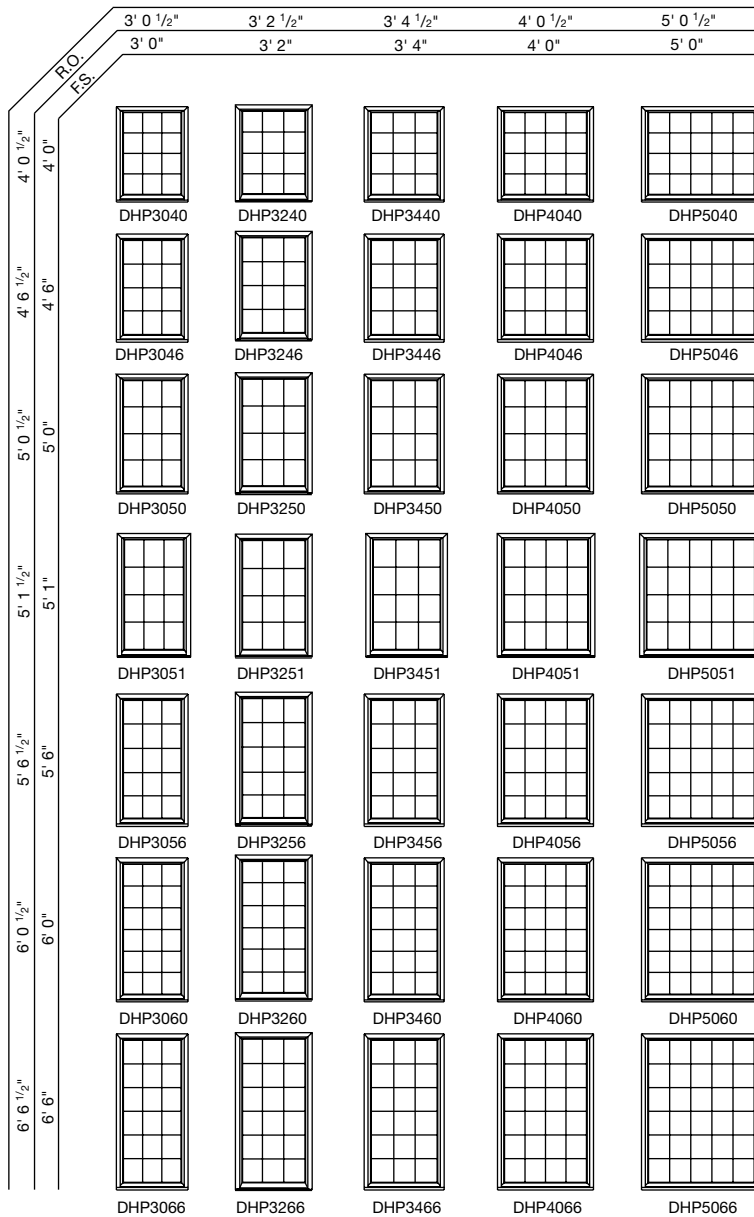

**NOTES**

If glass is positioned within 18" of the finished floor, safety/tempered glass may be required. Local codes may differ. Verify tempered glass requirements with your local building code official.

Use structural joining material when necessary or required by code.

The light patterns illustrated apply to rectangular removable interior wood grilles, Full Divided Light, Simulated Divided Light, Decorelle 100, 150 and 400 and Finelight™ Grilles-Between-the-Glass. All removable interior wood grilles will be installed in the units unless otherwise specified.

For a metric conversion in millimeters, multiply dimensions in inches by 25.4.

**FORMULA FOR COMBINATION WINDOWS**

The overall frame dimension (both width and height) is equal to the sum of the individual unit frame dimensions plus joining material dimension(s).

The overall rough opening (both width and height) is equal to the overall frame dimensions plus 1/4" on all sides.

E-Series Double-Hung Windows

### Double-Hung Transom Window Sizes

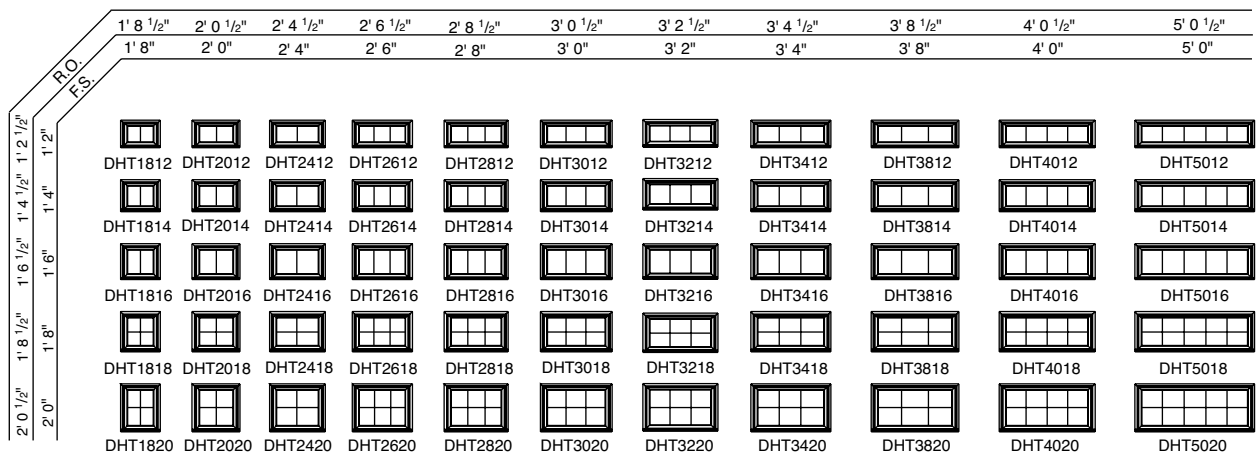

FOR WINDOWS OVER 30 SQUARE FEET OR RATED HIGHER THAN PG50, ONE OF THESE THREE INSTALLATION METHODS IS REQUIRED:  
A) THROUGH THE JAMB B) ALUMINUM NAILING FLANGE OR C) INSTALLATION CLIPS.  
ADDITIONAL CUSTOM SIZES ARE AVAILABLE. CONTACT YOUR LOCAL SUPPLIER FOR MORE INFORMATION. DRAWINGS ARE NOT TO SCALE.

# Arch Single-Hung Window Sizes

	2'-0 1/2"	4'-0 1/2"	2'-4 1/2"	4'-8 1/2"	2'-6 1/2"	5'-0 1/2"
	2'-0"	4'-0"	2'-4"	4'-8"	2'-6"	5'-0"
	3'-0" RAD	6'-0" RAD	3'-0" RAD	6'-0" RAD	3'-0" RAD	6'-0" RAD
3'-0" 3'-0"						
	RSHG2030	RSHG2030-2	RSHG2430	RSHG2430-2	RSHG2630	RSHG2630-2
3'-4 1/2" 3'-4"						
	RSHG2034	RSHG2034-2	RSHG2434	RSHG2434-2	RSHG2634	RSHG2634-2
4'-0 1/2" 4'-0"						
	RSHG2040	RSHG2040-2	RSHG2440	RSHG2440-2	RSHG2640	RSHG2640-2
4'-6 1/2" 4'-6"						
	RSHG2046	RSHG2046-2	RSHG2446	RSHG2446-2	RSHG2646	RSHG2646-2
5'-0 1/2" 5'-0"						
	RSHG2050	RSHG2050-2	RSHG2450	RSHG2450-2	RSHG2650	RSHG2650-2
5'-1 1/2" 5'-1"						
	RSHG2051	RSHG2051-2	RSHG2451	RSHG2451-2	RSHG2651	RSHG2651-2
5'-6 1/2" 5'-6"						
	RSHG2056	RSHG2056-2	RSHG2456	RSHG2456-2	RSHG2656	RSHG2656-2
6'-0 1/2" 6'-0"						
	RSHG2060	RSHG2060-2	RSHG2460	RSHG2460-2	RSHG2660	RSHG2660-2

**NOTES**

Units may be ordered with sash lifts if desired. Units 3'0" and wider will use two sash lifts.

Bottom sash operates up and down and tilts inward for cleaning. Top sash is fixed.

If glass is positioned within 18" of the finished floor, safety/tempered glass may be required. Local codes may differ. Verify tempered glass requirements with your local building code official.

Use structural joining material when necessary or required by code.

The light patterns illustrated apply to rectangular removable interior wood grilles, Full Divided Light, Simulated Divided Light, Decorelle 100, 150 and 400 and Finelight™ Grilles-Between-the-Glass. All removable interior wood grilles will be installed in the units unless otherwise specified.

For a metric conversion in millimeters, multiply dimensions in inches by 25.4.















































**FORMULA FOR COMBINATION WINDOWS**

The overall frame dimension (both width and height) is equal to the sum of the individual unit frame dimensions plus joining material dimension(s).

The overall rough opening (both width and height) is equal to the overall frame dimensions plus 1/4" on all sides.



## Arch Single-Hung Window Sizes

	2'-8 1/2"	5'-4 1/2"	3'-0 1/2"	6'-0 1/2"	3'-2 1/2"	6'-4 1/2"
	2'-8"	5'-4"	3'-0"	6'-0"	3'-2"	6'-4"
	3'-0" RAD	6'-0" RAD	3'-0" RAD	6'-0" RAD	3'-0" RAD	6'-0" RAD
3'-0 1/2" R.O. 3'-0"	 RSHG2830	 RSHG2830-2	 RSHG3030	 RSHG3030-2	 RSHG3230	
3'-4 1/2" R.O. 3'-4"	 RSHG2834	 RSHG2834-2	 RSHG3034	 RSHG3034-2	 RSHG3234	
4'-0 1/2" R.O. 4'-0"	 RSHG2840	 RSHG2840-2	 RSHG3040	 RSHG3040-2	 RSHG3240	 RSHG3240-2
4'-6 1/2" R.O. 4'-6"	 RSHG2846	 RSHG2846-2	 RSHG3046	 RSHG3046-2	 RSHG3246	 RSHG3246-2
5'-0 1/2" R.O. 5'-0"	 RSHG2850	 RSHG2850-2	 RSHG3050	 RSHG3050-2	 RSHG3250	 RSHG3250-2
5'-1 1/2" R.O. 5'-1"	 RSHG2851	 RSHG2851-2	 RSHG3051	 RSHG3051-2	 RSHG3251	 RSHG3251-2
5'-6 1/2" R.O. 5'-6"	 RSHG2856	 RSHG2856-2	 RSHG3056	 RSHG3056-2	 RSHG3256	 RSHG3256-2
6'-0 1/2" R.O. 6'-0"	 RSHG2860	 RSHG2860-2	 RSHG3060	 RSHG3060-2	 RSHG3260	 RSHG3260-2

### NOTES

Units may be ordered with sash lifts if desired. Units 3'0" and wider will use two sash lifts.

Bottom sash operates up and down and tilts inward for cleaning. Top sash is fixed.

If glass is positioned within 18" of the finished floor, safety/tempered glass may be required. Local codes may differ. Verify tempered glass requirements with your local building code official.

Use structural joining material when necessary or required by code.

The light patterns illustrated apply to rectangular removable interior wood grilles, Full Divided Light, Simulated Divided Light, Decorelle 100, 150 and 400 and Finelight™ Grilles-Between-the-Glass. All removable interior wood grilles will be installed in the units unless otherwise specified.

For a metric conversion in millimeters, multiply dimensions in inches by 25.4.

### FORMULA FOR COMBINATION WINDOWS

The overall frame dimension (both width and height) is equal to the sum of the individual unit frame dimensions plus joining material dimension(s).

The overall rough opening (both width and height) is equal to the overall frame dimensions plus 1/4" on all sides.

FOR WINDOWS OVER 30 SQUARE FEET OR RATED HIGHER THAN PG50, ONE OF THESE THREE INSTALLATION METHODS IS REQUIRED:  
A) THROUGH THE JAMB B) ALUMINUM NAILING FLANGE OR C) INSTALLATION CLIPS.

ADDITIONAL CUSTOM SIZES ARE AVAILABLE. CONTACT YOUR LOCAL SUPPLIER FOR MORE INFORMATION. DRAWINGS ARE NOT TO SCALE.

# Arch Reverse Cottage Single-Hung Window Sizes

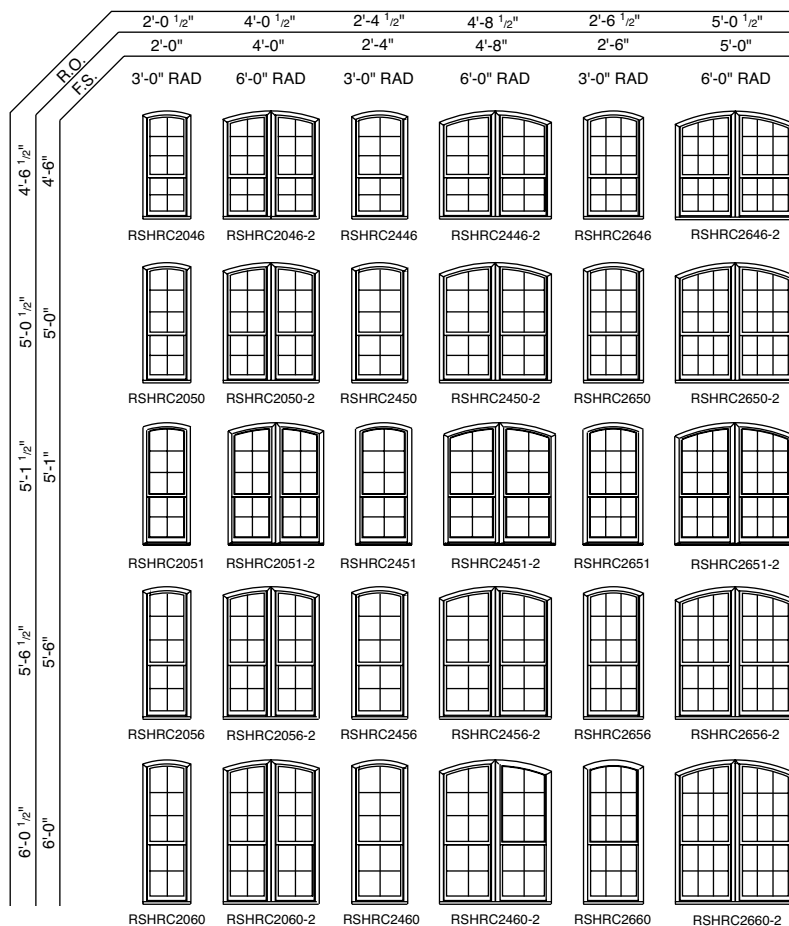

## NOTES

Units may be ordered with sash lifts if desired. Units 3'0" and wider will use two sash lifts.

Bottom sash operates up and down and tilts inward for cleaning. Top sash is fixed.

If glass is positioned within 18" of the finished floor, safety/tempered glass may be required. Local codes may differ. Verify tempered glass requirements with your local building code official.

Use structural joining material when necessary or required by code.

The light patterns illustrated apply to rectangular removable interior wood grilles, Full Divided Light, Simulated Divided Light, Decorelle 100, 150 and 400 and Finelight™ Grilles-Between-the-Glass. All removable interior wood grilles will be installed in the units unless otherwise specified.

For a metric conversion in millimeters, multiply dimensions in inches by 25.4.

## FORMULA FOR COMBINATION WINDOWS

The overall frame dimension (both width and height) is equal to the sum of the individual unit frame dimensions plus joining material dimension(s).

The overall rough opening (both width and height) is equal to the overall frame dimensions plus 1/4" on all sides.

### Arch Reverse Cottage Single-Hung Window Sizes

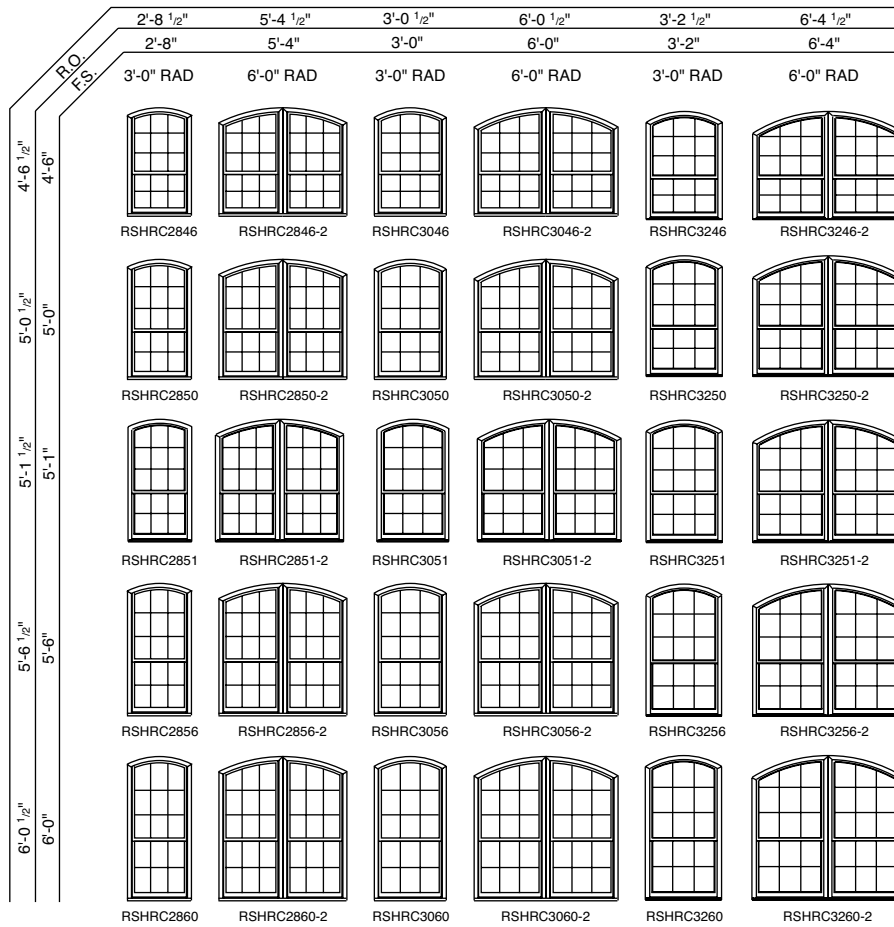

**NOTES**

Units may be ordered with sash lifts if desired. Units 3'0" and wider will use two sash lifts.

Bottom sash operates up and down and tilts inward for cleaning. Top sash is fixed.

If glass is positioned within 18" of the finished floor, safety/tempered glass may be required. Local codes may differ. Verify tempered glass requirements with your local building code official.

Use structural joining material when necessary or required by code.

The light patterns illustrated apply to rectangular removable interior wood grilles, Full Divided Light, Simulated Divided Light, Decorelle 100, 150 and 400 and Finelight™ Grilles-Between-the-Glass. All removable interior wood grilles will be installed in the units unless otherwise specified.

For a metric conversion in millimeters, multiply dimensions in inches by 25.4.

**FORMULA FOR COMBINATION WINDOWS**

The overall frame dimension (both width and height) is equal to the sum of the individual unit frame dimensions plus joining material dimension(s).

The overall rough opening (both width and height) is equal to the overall frame dimensions plus 1/4" on all sides.

E-Series Double-Hung Windows

### Double-Hung Direct-Set Transom Window Sizes

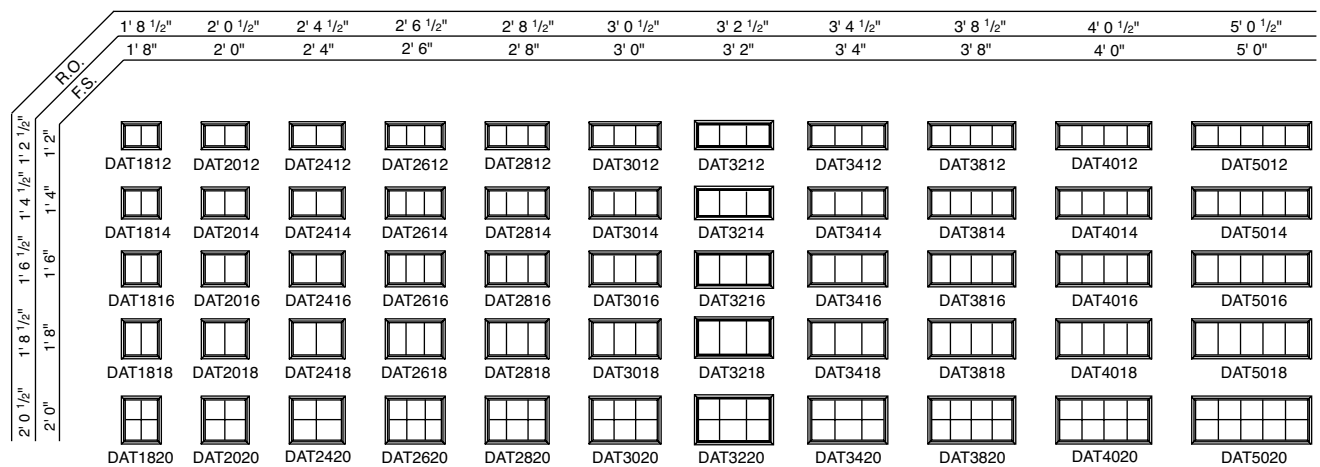

# Monumental Single-Hung Window Sizes

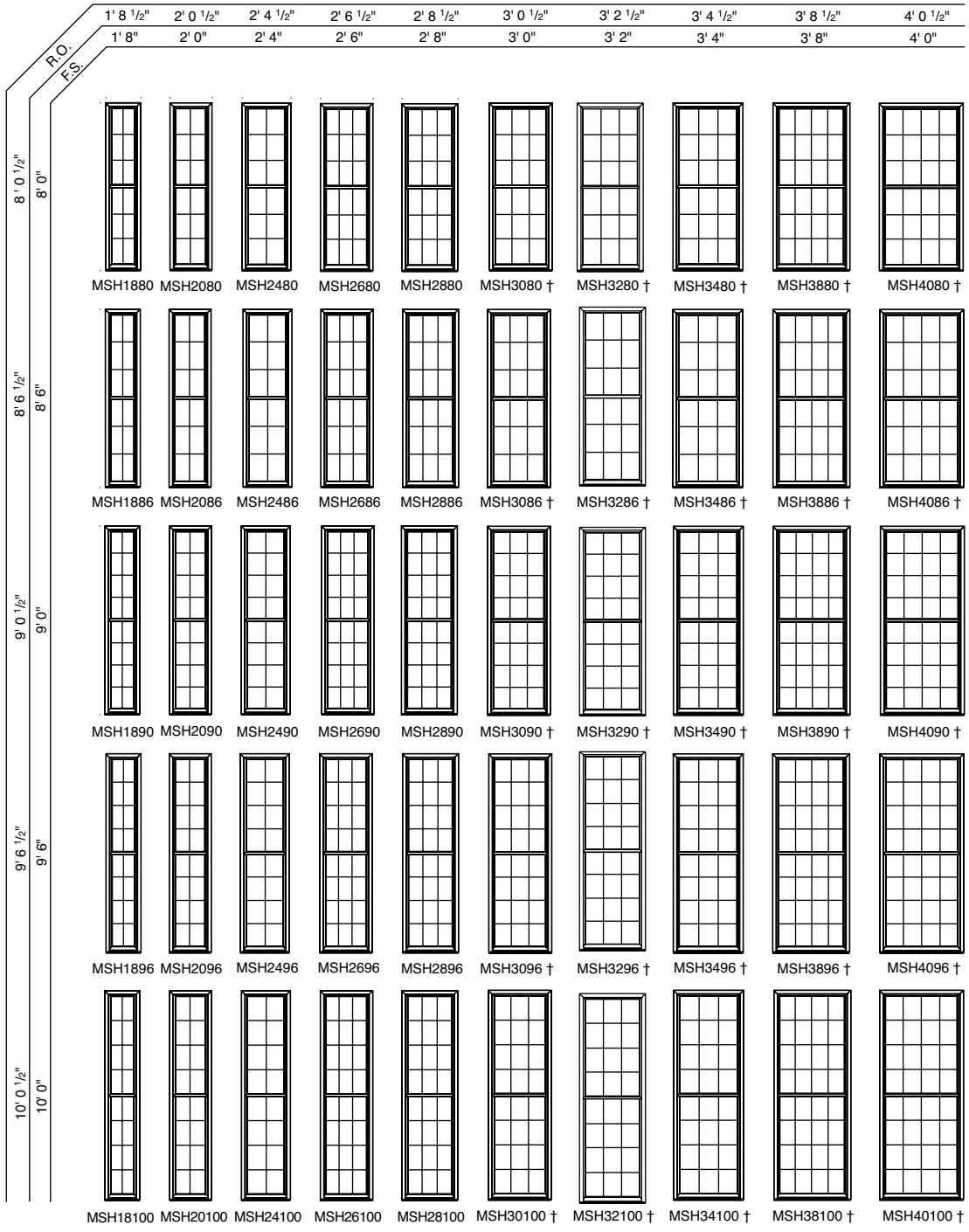

**NOTES**

† These units meet or exceed the following dimensions: Clear Opening Area 5.7 sq. ft., Clear Opening Width 20", Clear Opening Height 24" and 44" maximum floor to sill height (with standard 6'10-1/2" structural header height). See your local code official for requirements in your area.

Units may be ordered with sash lifts if desired. Units 3'0" and wider will use two sash lifts.

Bottom sash operates up and down but does not tilt. Top sash is fixed.

Units equal to or greater than 8'0" tall are limited to 24" of clear opening height.

Sash Ratio: Standard units are equal sash. However, Cottage and Reverse Cottage are available as an option with some limitations. Contact your local supplier for more information.

See notes on page 73 for more information.

## Monumental Single-Hung Window Sizes

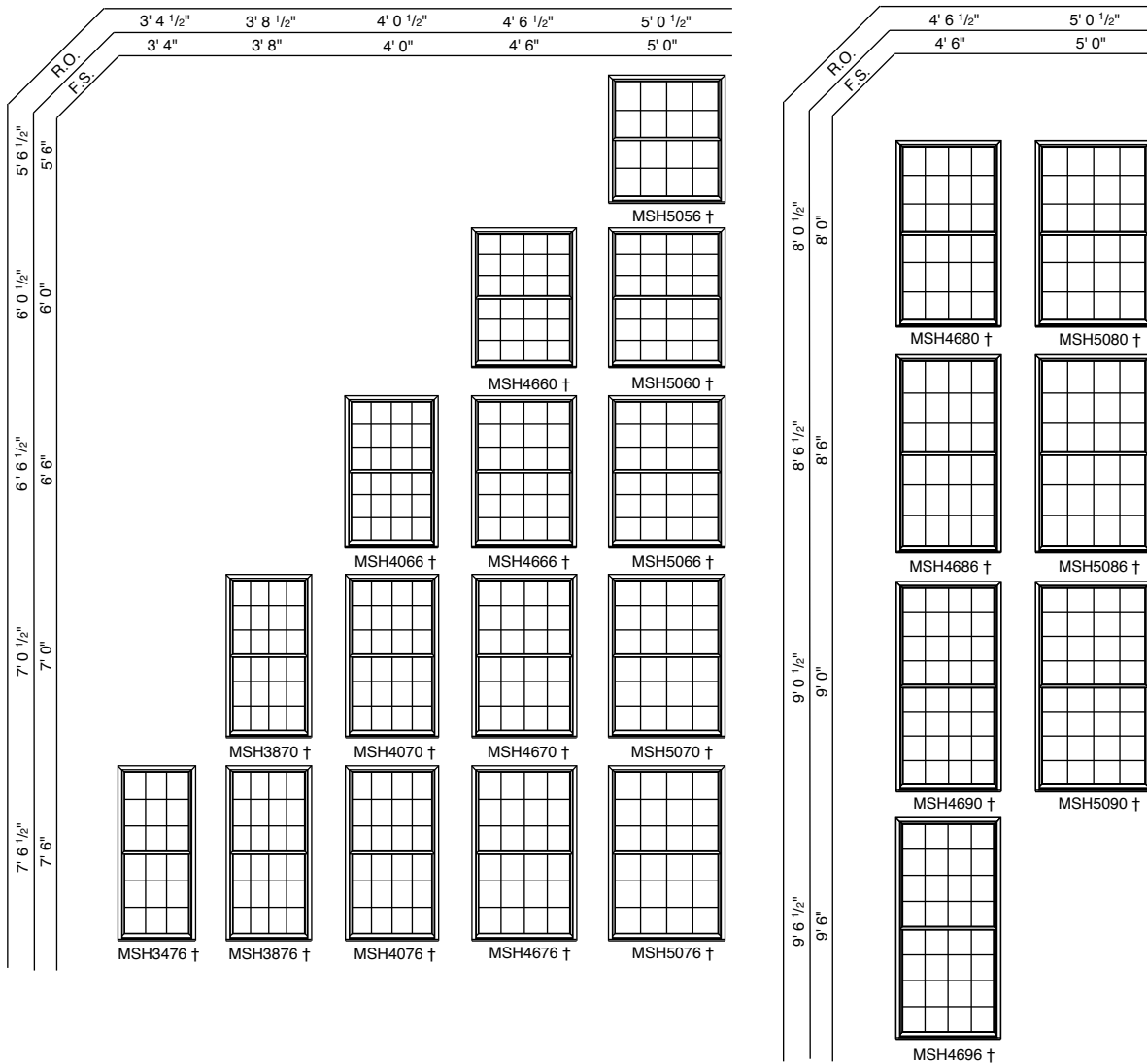

### NOTES

† These units meet or exceed the following dimensions: Clear Opening Area 5.7 sq. ft., Clear Opening Width 20", Clear Opening Height 24" and 44" maximum floor to sill height (with standard 6'10-1/2" structural header height). See your local code official for requirements in your area.

Units may be ordered with sash lifts if desired. Units 3'0" and wider will use two sash lifts.

Bottom sash operates up and down but does not tilt. Top sash is fixed.

Units equal to or greater than 8'0" tall are limited to 24" of clear opening height.

Sash Ratio: Standard units are equal sash. However, Cottage and Reverse Cottage are available as an option with some limitations. Contact your local supplier for more information.

If glass is positioned within 18" of the finished floor, safety/tempered glass may be required. Local codes may differ. Verify tempered glass requirements with your local building code official.

Use structural joining material when necessary or required by code.

The light patterns illustrated apply to rectangular removable interior wood grilles, Full Divided Light, Simulated Divided Light, Decorelle 100, 150 and 400 and Finelight™ Grilles-Between-the-Glass. All removable interior wood grilles will be installed in the units unless otherwise specified.

For a metric conversion in millimeters, multiply dimensions in inches by 25.4.

### FORMULA FOR COMBINATION WINDOWS

The overall frame dimension (both width and height) is equal to the sum of the individual unit frame dimensions plus joining material dimension(s).

The overall rough opening (both width and height) is equal to the overall frame dimensions plus 1/4" on all sides.

# Double-Hung Windows

**Double-Hung**

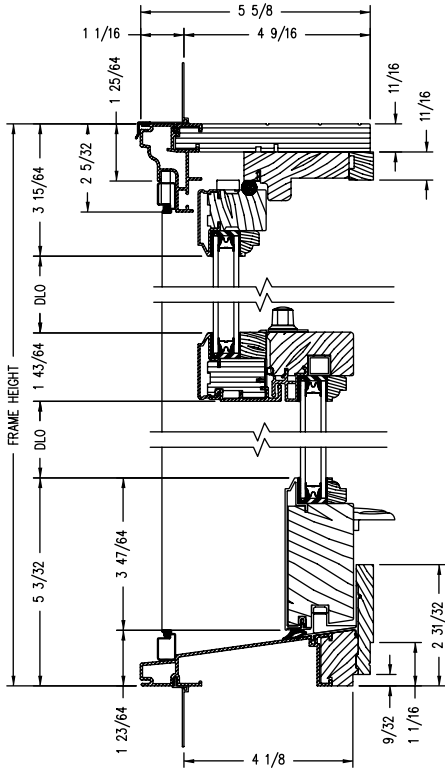

Vertical Section

**Double-Hung Picture**

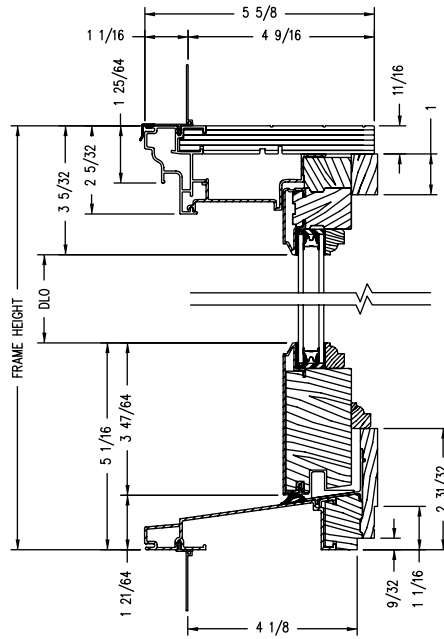

Vertical Section

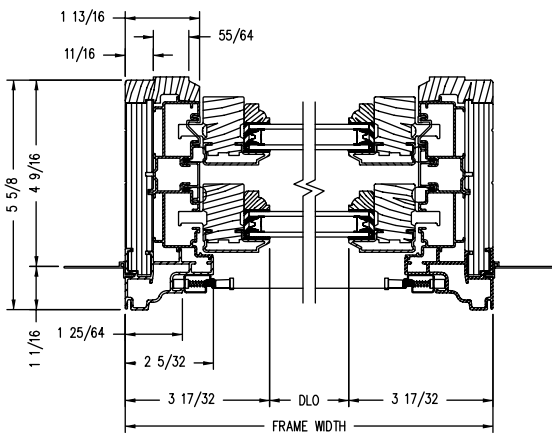

Horizontal Section

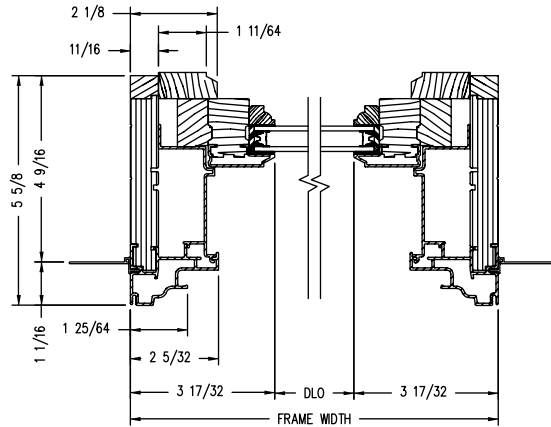

Horizontal Section

Shown with ovolo (colonial) glass stops.



## Double-Hung Insert Windows

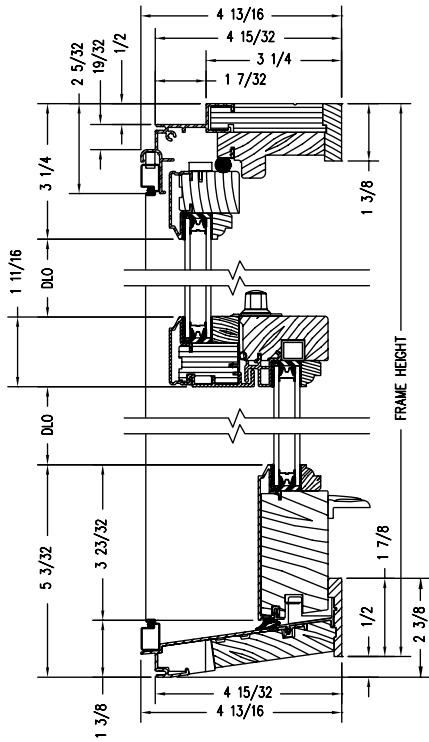

Vertical Section  
(For sill angles 8° and greater)

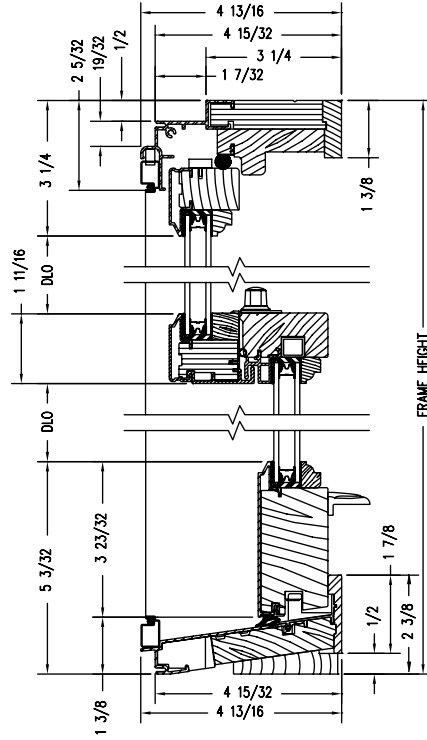

Vertical Section  
(For sill angles less than 8°)

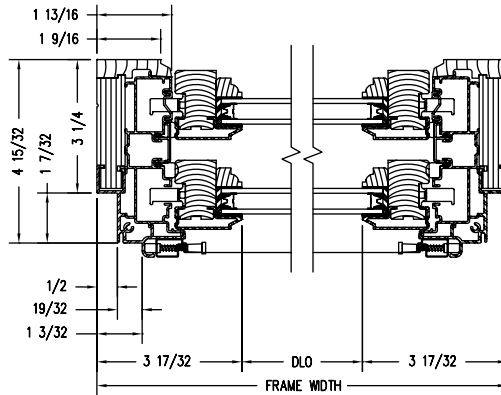

Horizontal Section

Shown with ovolo (colonial) glass stops.

## Double-Hung Picture Insert Windows

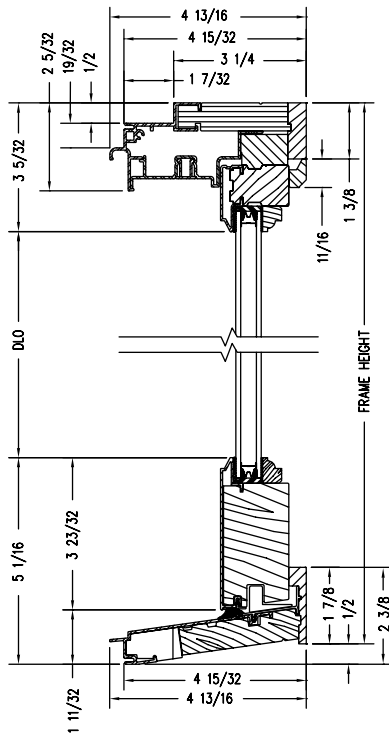

Vertical Section  
(For sill angles 8° and greater)

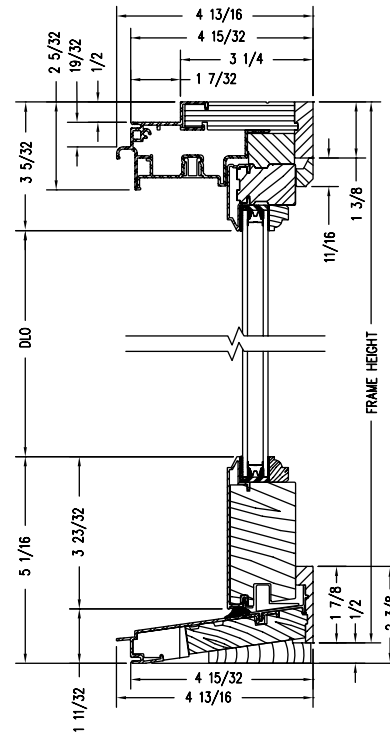

Vertical Section  
(For sill angles less than 8°)

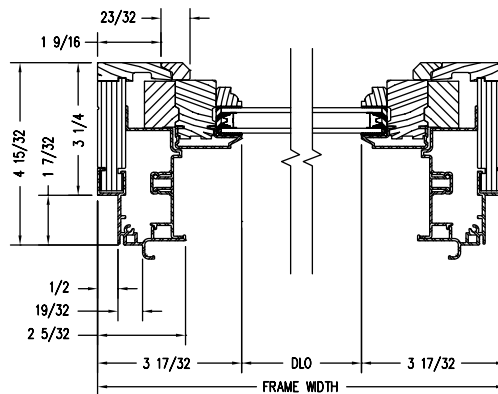

Horizontal Section

Shown with ovolo (colonial) glass stops.

# Double-Hung Sash Replacement Kits

## Double-Hung Sash Replacement

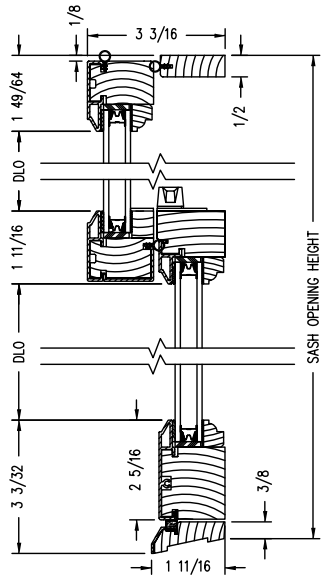

Vertical Section

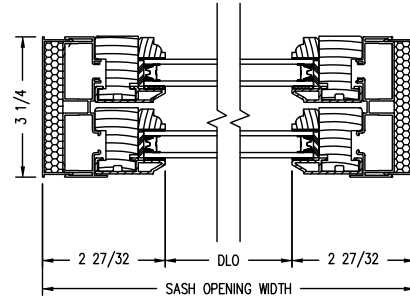

Horizontal Section

## Double-Hung Picture Sash Replacement

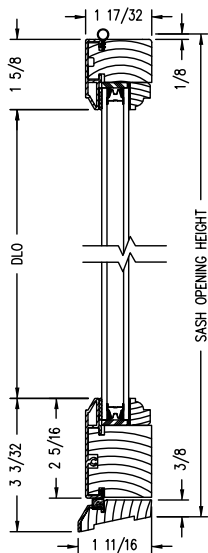

Vertical Section

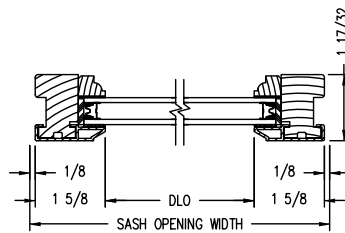

Horizontal Section

Shown with ovolo (colonial) glass stops.

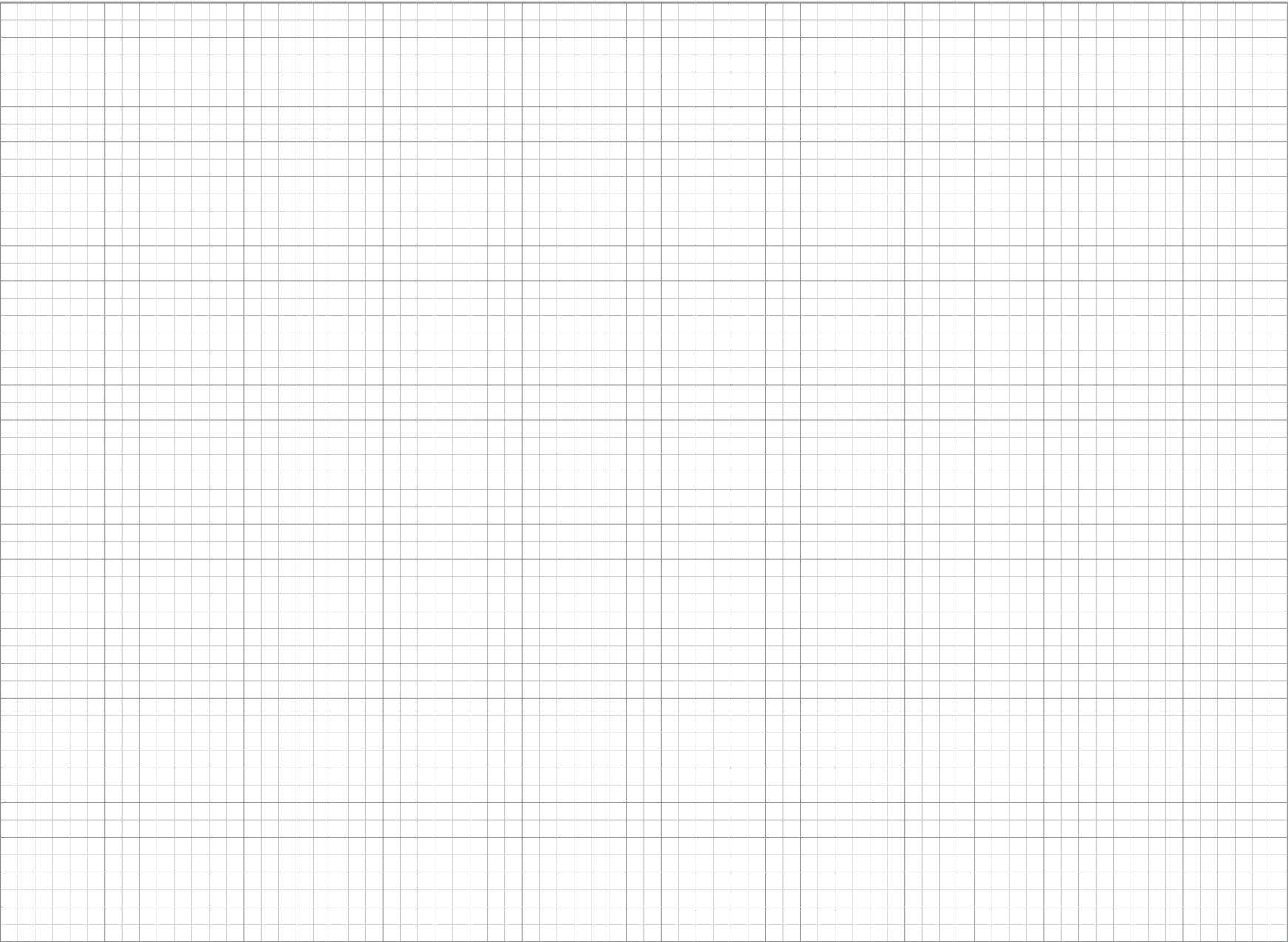

# Bay & Bow Windows

E-Series bay and bow windows provide a focal point that is architecturally consistent inside and out, making any room feel spacious. They feature consistent sight lines when integrated with double-hung or casement windows, head and seat boards in your wood selection and an all-inclusive accessory package when ordered as a kit.

---

<b>Bay &amp; Bow Overview</b> .....	<b>82</b>
Sizing	
10° Casement Bow .....	<b>84</b>
30° & 45° Casement Bay .....	<b>85</b>
90° Casement Box Bay .....	<b>86</b>
30° Double-Hung Bay .....	<b>89</b>
45° Double-Hung Bay .....	<b>90</b>
Details	
Casement .....	<b>87</b>
Double-Hung .....	<b>91</b>
Installation Materials .....	<b>154</b>
Product Performance .....	<b>158</b>





E-Series casement bow and picture windows with clear anodized exterior finish.

# Bay & Bow Windows



## Frame & Sash

① Select wood components are kiln dried and treated with water/insect repellent and preservative. Interior wood surfaces are available in pine, mixed grain douglas fir, cherry, hickory, mahogany,\* maple, oak, walnut, alder or vertical grain Douglas fir. Interior surfaces are available unfinished or factory primed. Optional factory-applied finishes are available in a variety of stain and paint options.

Wood components are fitted with aluminum extrusions on the exterior. 50 exterior colors that meet AAMA 2604 and 2605 specifications are available, as well as custom colors. Also available is a selection of seven exterior anodized options.

## Glazing

② High-Performance Low-E4\* glass with a low-conductivity spacer. Triple-pane glass, tinted, clear dual-pane, high-altitude glass and other special glazing options are available.

Glass is fixed in place from the interior with wood stops that can be removed for easy reglazing if necessary. Glass stops are available in ovolo (colonial) and contemporary profiles.

## Weatherstrip

Compression bulb weatherstrip is applied for a maximum weather seal.

## Head & Seat Boards

③ Wood head and seat boards are available in birch or oak.

## Hardware

④ See casement or double-hung sections for detailed hardware options.

## Window Anchorage

Support is required underneath all bay and bow units. We offer a cable support system for your use. Insulated platforms and brackets are not included.

## ⑤ Insect Screens

Charcoal fiberglass screen mesh fits into an aluminum frame. Aluminum screen mesh is available as an option.

See casement or double-hung sections for additional insect screen options.

### *Cable Support System*



## Features & Options

<p><b>4</b></p> <p><i>Casement Operator Handles &amp; Covers</i></p> <p>Bronze Polished Brass Gold White Black Antique Brass Pewter Oil Rubbed Bronze Satin Chrome Bright Chrome</p>	<p><i>Casement Sash Locks</i></p> <p>Bronze Polished Brass Gold White Black Antique Brass Pewter Oil Rubbed Bronze Satin Chrome Bright Chrome</p>	<p><b>5</b></p> <p><i>Insect Screens</i></p>
<p><i>Double-Hung Sash Lifts</i></p> <p>Bronze Polished Brass Gold White Black Antique Brass Pewter Oil Rubbed Bronze Satin Chrome Bright Chrome</p>	<p><i>Double-Hung Sash Locks</i></p> <p>Bronze Polished Brass Gold White Black Antique Brass Pewter Oil Rubbed Bronze Satin Chrome Bright Chrome</p>	<p><b>6</b></p> <p><i>Grilles</i></p> <p>5/8" FDL    7/8" FDL    1 1/8" FDL 1 1/2" FDL    7/8" SDL    7/8" Removable 5/8" Flat    1" Contoured</p> <p>FDL = Full Divided Light* SDL = Simulated Divided Light* Removable = Removable interior wood grilles Flat = Finelight™ grilles-between-the-glass Contoured = Finelight grilles-between-the-glass</p>

### 6 Grilles

**Full Divided Light.** Permanent interior and exterior grilles with grille spacer bars between two panes of glass. Available in 5/8", 7/8", 1 1/8", 1 1/2" or 2 1/4" widths and ovolo (colonial) or contemporary profiles.

**Simulated Divided Light.** Permanent exterior and interior grilles without grille spacer bars. Available in 5/8", 7/8", 1 1/8", 1 1/2" or 2 1/4" widths and ovolo or contemporary profiles.

### Finelight™ Grilles-Between-the-Glass.

Available in 5/8" flat or 1" contoured aluminum profiles. Two-tone colors of pebble tan/colony white, sierra bronze/colony white or forest green/colony white are available on the 1" profile.

### Removable interior wood grilles.

Removable interior wood grilles are available in a 7/8" width and ovolo or contemporary profiles. Optional surround for removable grille and permanent exterior grilles also available.

### Privacy Options

#### System 3 Blinds (Casement only).

A 5/8" aluminum slat blind is mounted to an extruded aluminum blind panel and applied to the window, creating a triple-glazed window boasting privacy and energy efficiency. Available in three colors. Blind panels are offered in white, tan, gold or an optional wood veneer to match your interior.

#### System 3 Shades (Casement only).

Pleated fabric shades are available in four colors to effortlessly and beautifully filter the light. See page 25 for more details.

\* FDL & SDL grille options also available in 2 1/4" width and in contemporary profile. See page 22 for more information. Oil rubbed bronze is a "living" finish that will change with time and use.

Printing limitations prevent exact finish replication. Please see your Andersen supplier for actual finish samples.

# 10° Casement Bow Window Sizes

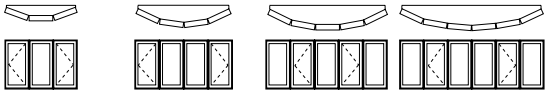

		WIDTH			
Rough Opp.	3-WIDE 4'-6 3/16"	4-WIDE 5'-11 5/8"	5-WIDE 7'-4 9/16"	6-WIDE 8'-8 3/4"	
3'-0 1/2"	15 3/4 30-3	15 3/4 30-4	15 3/4 30-5	15 3/4 30-6	
3'-4 1/2"	15 3/4 34-3	15 3/4 34-4	15 3/4 34-5	15 3/4 34-6	
4'-0 1/2"	15 3/4 40-3	15 3/4 40-4	15 3/4 40-5	15 3/4 40-6	
4'-6 1/2"	15 3/4 46-3	15 3/4 46-4	15 3/4 46-5	15 3/4 46-6	
5'-0 1/2"	15 3/4 50-3	15 3/4 50-4	15 3/4 50-5	15 3/4 50-6	
5'-6 1/2"	15 3/4 56-3	15 3/4 56-4	15 3/4 56-5	15 3/4 56-6	
6'-0 1/2"	15 3/4 60-3	15 3/4 60-4	15 3/4 60-5	15 3/4 60-6	
Projection	0'-3 5/32"	0'-6 1/4"	0'-9 11/32"	1'-1 15/16"	
Rough Opp.	5'-0 7/8"	6'-8 1/2"	8'-3 7/16"	9'-9 11/16"	
3'-0 1/2"	1830-3	1830-4	1830-5	1830-6	
3'-4 1/2"	1834-3	1834-4	1834-5	1834-6	
4'-0 1/2"	1840-3	1840-4	1840-5	1840-6	
4'-6 1/2"	1846-3	1846-4	1846-5	1846-6	
5'-0 1/2"	1850-3	1850-4	1850-5	1850-6	
5'-6 1/2"	1856-3	1856-4	1856-5	1856-6	
6'-0 1/2"	1860-3	1860-4	1860-5	1860-6	
Projection	0'-3 9/16"	0'-7 1/32"	0'-10 1/2"	1'-3 21/32"	
Rough Opp.	6'-0 3/4"	8'-0 3/16"	9'-10 7/8"	11'-8 5/8"	
3'-0 1/2"	2030-3	2030-4	2030-5	2030-6	
3'-4 1/2"	2034-3	2034-4	2034-5	2034-6	
4'-0 1/2"	2040-3	2040-4	2040-5	2040-6	
4'-6 1/2"	2046-3	2046-4	2046-5	2046-6	
5'-0 1/2"	2050-3	2050-4	2050-5	2050-6	
5'-6 1/2"	2056-3	2056-4	2056-5	2056-6	
6'-0 1/2"	2060-3	2060-4	2060-5	2060-6	
Projection	0'-4 1/4"	0'-8 13/32"	1'-0 9/16"	1'-6 3/4"	
Rough Opp.	7'-0 5/8"	9'-3 7/8"	11'-6 1/4"		
3'-0 1/2"	2430-3	2430-4	2430-5	-----	
3'-4 1/2"	2434-3	2434-4	2434-5	-----	
4'-0 1/2"	2440-3	2440-4	2440-5	-----	
4'-6 1/2"	2446-3	2446-4	2446-5	-----	
5'-0 1/2"	2450-3	2450-4	2450-5	-----	
5'-6 1/2"	2456-3	2456-4	2456-5	-----	
6'-0 1/2"	2460-3	2460-4	2460-5	-----	
Projection	0'-4 15/16"	0'-9 13/16"	1'-2 5/8"	-----	
Rough Opp.	7'-6 9/16"	9'-11 11/16"	12'-3 15/16"		
3'-0 1/2"	2630-3	2630-4	2630-5	-----	
3'-4 1/2"	2634-3	2634-4	2634-5	-----	
4'-0 1/2"	2640-3	2640-4	2640-5	-----	
4'-6 1/2"	2646-3	2646-4	2646-5	-----	
5'-0 1/2"	2650-3	2650-4	2650-5	-----	
5'-6 1/2"	2656-3	2656-4	2656-5	-----	
6'-0 1/2"	2660-3	2660-4	2660-5	-----	
Projection	0'-5 5/16"	0'-10 1/2"	1'-3 21/32"	-----	

**NOTES**  
Projection is measured from the outside of the exterior sheathing to the exterior sheathing line of the outermost unit.

Support is required underneath all bay and bow units. For additional support, we offer a cable support system.

Insulated platforms and brackets are not included.

HEIGHT

### 30° Casement Angle Bay Window Sizes

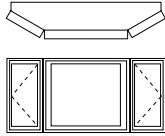

**NOTES**

Projection is measured from the outside of the exterior sheathing to the exterior sheathing line of the outermost unit.

Support is required underneath all bay and bow units. For additional support, we offer a cable support system.

Insulated platforms and brackets are not included.

		WIDTH						
		30 Degree Casement Angle Bay Units						
HEIGHT	Rough Opg.	6'-5 11/16"	7'-1 11/16"	8'-1 11/16"	7'-0 5/8"	7'-8 5/8"	8'-8 5/8"	
			1'-8" Wide Flanker Units			2'-0" Wide Flanker Units		
			3'-4" Center	4'-0" Center	5'-0" Center	3'-4" Center	4'-0" Center	5'-0" Center
	4'-0 1/2"	1840/3440/1840	1840/4040/1840	1840/5040/1840	2040/3440/2040	2040/4040/2040	2040/5040/2040	
	4'-6 1/2"	1846/3446/1846	1846/4046/1846	1846/5046/1846	2046/3446/2046	2046/4046/2046	2046/5046/2046	
	5'-0 1/2"	1850/3450/1850	1850/4050/1850	1850/5050/1850	2050/3450/2050	2050/4050/2050	2050/5050/2050	
	5'-6 1/2"	1856/3456/1856	1856/4056/1856	1856/5056/1856	2056/3456/2056	2056/4056/2056	2056/5056/2056	
	6'-0 1/2"	1860/3460/1860	1860/4060/1860	1860/5060/1860	2060/3460/2060	2060/4060/2060	2060/5060/2060	
	Projection	0'-10 17/32"	0'-10 17/32"	0'-10 17/32"	1'-0 17/32"	1'-0 17/32"	1'-0 17/32"	
		30 Degree Casement Angle Bay Units						
HEIGHT	Rough Opg.	7'-7 9/16"	8'-3 9/16"	9'-3 9/16"	7'-11"	8'-7"	9'-7"	
			2'-4" Wide Flanker Units			2'-6" Wide Flanker Units		
			3'-4" Center	4'-0" Center	5'-0" Center	3'-4" Center	4'-0" Center	5'-0" Center
	4'-0 1/2"	2440/3440/2440	2440/4040/2440	2440/5040/2440	2640/3440/2640	2640/4040/2640	2640/5040/2640	
	4'-6 1/2"	2446/3446/2446	2446/4046/2446	2446/5046/2446	2646/3446/2646	2646/4046/2646	2646/5046/2646	
	5'-0 1/2"	2450/3450/2450	2450/4050/2450	2450/5050/2450	2650/3450/2650	2650/4050/2650	2650/5050/2650	
	5'-6 1/2"	2456/3456/2456	2456/4056/2456	2456/5056/2456	2656/3456/2656	2656/4056/2656	2656/5056/2656	
	6'-0 1/2"	2460/3460/2460	2460/4060/2460	2460/5060/2460	2660/3460/2660	2660/4060/2660	2660/5060/2660	
	Projection	1'-2 17/32"	1'-2 17/32"	1'-2 17/32"	1'-3 17/32"	1'-3 17/32"	1'-3 17/32"	

### 45° Casement Angle Bay Window Sizes

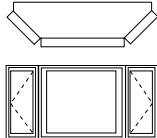

		WIDTH						
		45 Degree Casement Angle Bay Units						
HEIGHT	Rough Opg.	6'-0 3/4"	6'-8 3/4"	7'-8 3/4"	6'-6 3/8"	7'-2 3/8"	8'-2 3/8"	
			1'-8" Wide Flanker Units			2'-0" Wide Flanker Units		
			3'-4" Center	4'-0" Center	5'-0" Center	3'-4" Center	4'-0" Center	5'-0" Center
	4'-0 1/2"	1840/3440/1840	1840/4040/1840	1840/5040/1840	2040/3440/2040	2040/4040/2040	2040/5040/2040	
	4'-6 1/2"	1846/3446/1846	1846/4046/1846	1846/5046/1846	2046/3446/2046	2046/4046/2046	2046/5046/2046	
	5'-0 1/2"	1850/3450/1850	1850/4050/1850	1850/5050/1850	2050/3450/2050	2050/4050/2050	2050/5050/2050	
	5'-6 1/2"	1856/3456/1856	1856/4056/1856	1856/5056/1856	2056/3456/2056	2056/4056/2056	2056/5056/2056	
	6'-0 1/2"	1860/3460/1860	1860/4060/1860	1860/5060/1860	2060/3460/2060	2060/4060/2060	2060/5060/2060	
	Projection	1'-3 5/32"	1'-3 5/32"	1'-3 5/32"	1'-6"	1'-6"	1'-6"	
		45 Degree Casement Angle Bay Units						
HEIGHT	Rough Opg.	7'-0"	7'-8"	8'-8"	7'-2 7/8"	7'-10 7/8"	8'-10 7/8"	
			2'-4" Wide Flanker Units			2'-6" Wide Flanker Units		
			3'-4" Center	4'-0" Center	5'-0" Center	3'-4" Center	4'-0" Center	5'-0" Center
	4'-0 1/2"	2440/3440/2440	2440/4040/2440	2440/5040/2440	2640/3440/2640	2640/4040/2640	2640/5040/2640	
	4'-6 1/2"	2446/3446/2446	2446/4046/2446	2446/5046/2446	2646/3446/2646	2646/4046/2646	2646/5046/2646	
	5'-0 1/2"	2450/3450/2450	2450/4050/2450	2450/5050/2450	2650/3450/2650	2650/4050/2650	2650/5050/2650	
	5'-6 1/2"	2456/3456/2456	2456/4056/2456	2456/5056/2456	2656/3456/2656	2656/4056/2656	2656/5056/2656	
	6'-0 1/2"	2460/3460/2460	2460/4060/2460	2460/5060/2460	2660/3460/2660	2660/4060/2660	2660/5060/2660	
	Projection	1'-8 13/16"	1'-8 13/16"	1'-8 13/16"	1'-10 7/32"	1'-10 7/32"	1'-10 7/32"	

FOR WINDOWS OVER 30 SQUARE FEET OR RATED HIGHER THAN PG50, ONE OF THESE THREE INSTALLATION METHODS IS REQUIRED:  
A) THROUGH THE JAMB B) ALUMINUM NAILING FLANGE OR C) INSTALLATION CLIPS.  
ADDITIONAL CUSTOM SIZES ARE AVAILABLE. CONTACT YOUR LOCAL SUPPLIER FOR MORE INFORMATION. DRAWINGS ARE NOT TO SCALE.





### 3-Wide 10° Casement Bow Windows

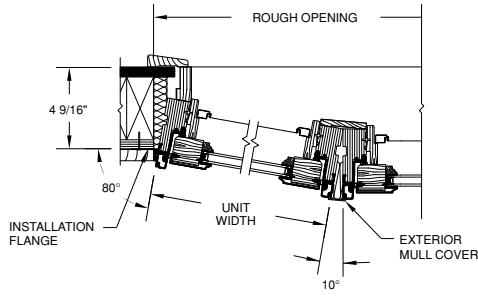

Horizontal Section

### 4-Wide 10° Casement Bow Windows

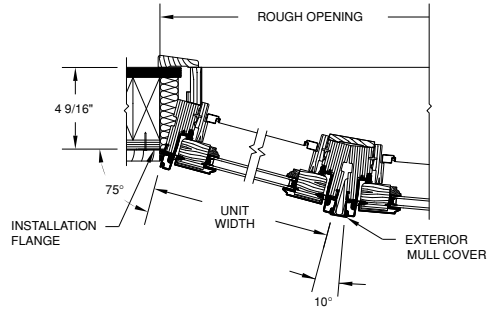

Horizontal Section

### 5-Wide 10° Casement Bow Windows

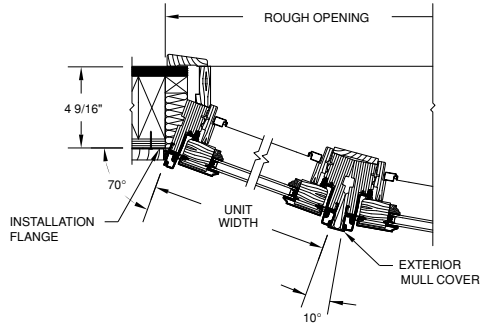

Horizontal Section

### 6-Wide 10° Casement Bow Windows

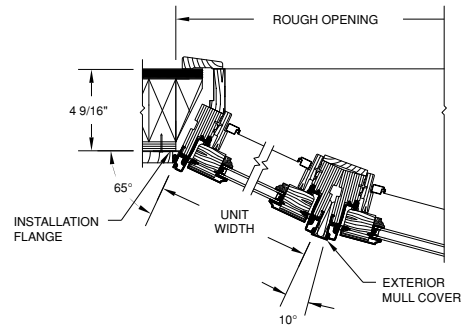

Horizontal Section

### 30° Casement Angle Bay Windows

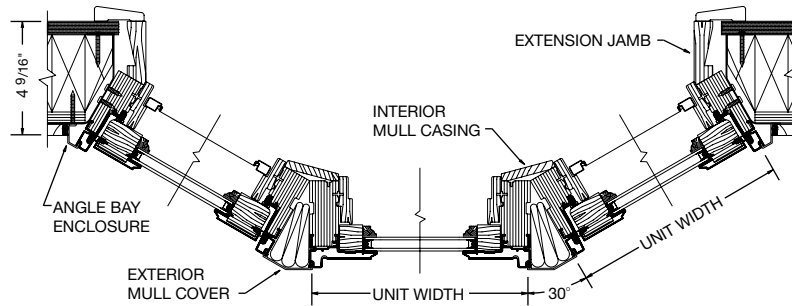

Horizontal Section

Shown with ovolo (colonial) glass stops.

## 45° Casement Angle Bay Windows

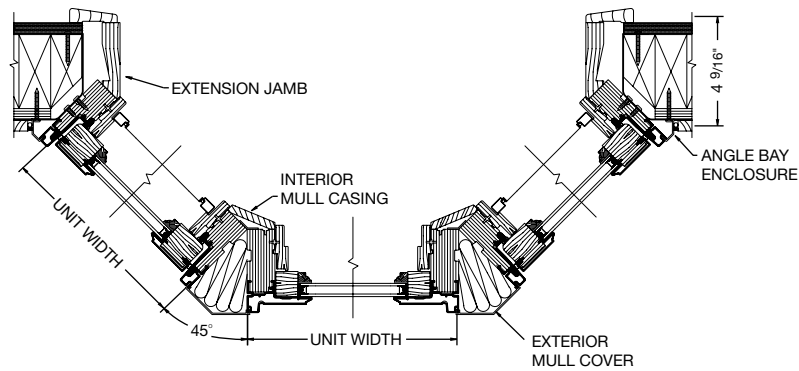

Horizontal Section

## Casement Bay/Bow Windows

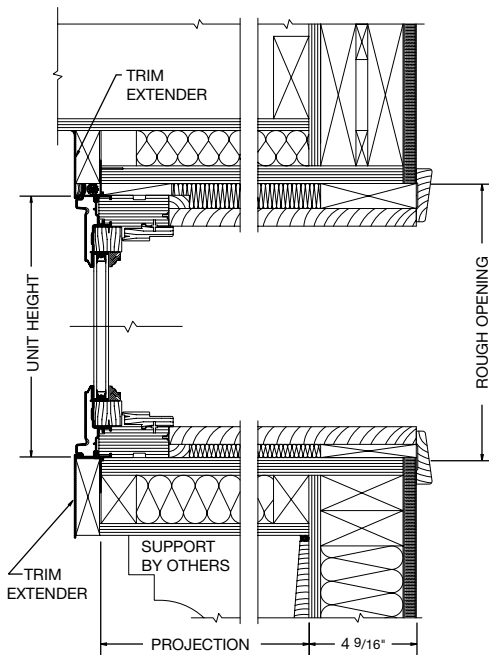

Vertical Section

## 90° Casement Box Bay Windows

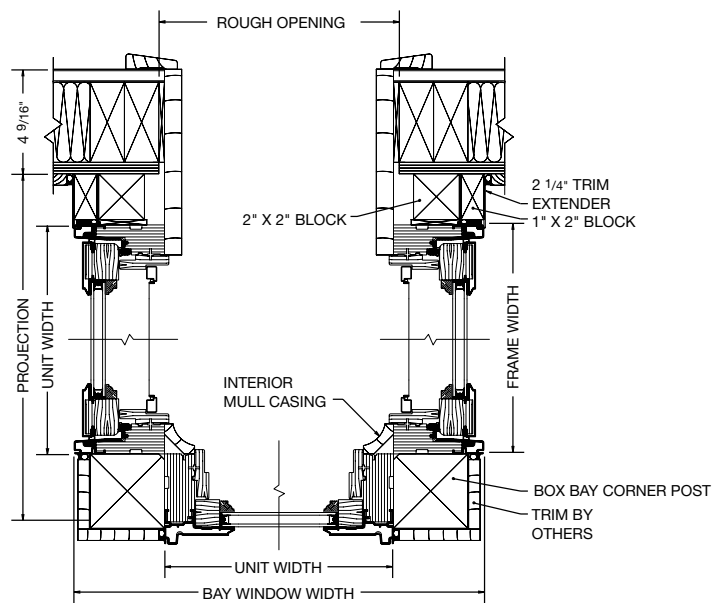

Horizontal Section

Shown with ovolo (colonial) glass stops.

### 30° Double-Hung Angle Bay Window Sizes

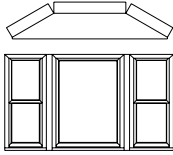

WIDTH					
30 Degree Double-Hung Angle Bay Units					
Rough Opp.	6'-3 11/16"	6'-5 11/16"	6'-7 11/16"	7'-3 11/16"	8'-3 11/16"
	1'-8" Wide Flanker Units				
	3'-0" Center	3'-2" Center	3'-4" Center	4'-0" Center	5'-0" Center
4'-0 1/2"	1840/3040/1840	1840/3240/1840	1840/3440/1840	1840/4040/1840	1840/5040/1840
4'-6 1/2"	1846/3046/1846	1846/3246/1846	1846/3446/1846	1846/4046/1846	1846/5046/1846
4'-9 1/2"	1849/3049/1849	1849/3249/1849	1849/3449/1849	1849/4049/1849	1849/5049/1849
5'-0 1/2"	1850/3050/1850	1850/3250/1850	1850/3450/1850	1850/4050/1850	1850/5050/1850
5'-1 1/2"	1851/3051/1851	1851/3251/1851	1851/3451/1851	1851/4051/1851	1851/5051/1851
5'-6 1/2"	1856/3056/1856	1856/3256/1856	1856/3456/1856	1856/4056/1856	1856/5056/1856
6'-0 1/2"	1860/3060/1860	1860/3260/1860	1860/3460/1860	1860/4060/1860	1860/5060/1860
Projection	0'-10 3/4"	0'-10 3/4"	0'-10 3/4"	0'-10 3/4"	0'-10 3/4"
Rough Opp.	6'-10 5/8"	7'-0 5/8"	7'-2 5/8"	7'-10 5/8"	8'-10 5/8"
	2'-0" Wide Flanker Units				
	3'-0" Center	3'-2" Center	3'-4" Center	4'-0" Center	5'-0" Center
4'-0 1/2"	2040/3040/2040	2040/3240/2040	2040/3440/2040	2040/4040/2040	2040/5040/2040
4'-6 1/2"	2046/3046/2046	2046/3246/2046	2046/3446/2046	2046/4046/2046	2046/5046/2046
4'-9 1/2"	2049/3049/2049	2049/3249/2049	2049/3449/2049	2049/4049/2049	2049/5049/2049
5'-0 1/2"	2050/3050/2050	2050/3250/2050	2050/3450/2050	2050/4050/2050	2050/5050/2050
5'-1 1/2"	2051/3051/2051	2051/3251/2051	2051/3451/2051	2051/4051/2051	2051/5051/2051
5'-6 1/2"	2056/3056/2056	2056/3256/2056	2056/3456/2056	2056/4056/2056	2056/5056/2056
6'-0 1/2"	2060/3060/2060	2060/3260/2060	2060/3460/2060	2060/4060/2060	2060/5060/2060
Projection	1'-0 3/4"	1'-0 3/4"	1'-0 3/4"	1'-0 3/4"	1'-0 3/4"
Rough Opp.	7'-5 1/2"	7'-7 1/2"	7'-9 1/2"	8'-5 1/2"	9'-5 1/2"
	2'-4" Wide Flanker Units				
	3'-0" Center	3'-2" Center	3'-4" Center	4'-0" Center	5'-0" Center
4'-0 1/2"	2440/3040/2440	2440/3240/2440	2440/3440/2440	2440/4040/2440	2440/5040/2440
4'-6 1/2"	2446/3046/2446	2446/3246/2446	2446/3446/2446	2446/4046/2446	2446/5046/2446
4'-9 1/2"	2449/3049/2449	2449/3249/2449	2449/3449/2449	2449/4049/2449	2449/5049/2449
5'-0 1/2"	2450/3050/2450	2450/3250/2450	2450/3450/2450	2450/4050/2450	2450/5050/2450
5'-1 1/2"	2451/3051/2451	2451/3251/2451	2451/3451/2451	2451/4051/2451	2451/5051/2451
5'-6 1/2"	2456/3056/2456	2456/3256/2456	2456/3456/2456	2456/4056/2456	2456/5056/2456
6'-0 1/2"	2460/3060/2460	2460/3260/2460	2460/3460/2460	2460/4060/2460	2460/5060/2460
Projection	1'-2 3/4"	1'-2 3/4"	1'-2 3/4"	1'-2 3/4"	1'-2 3/4"

**NOTES**

Projection is measured from the outside of the exterior sheathing to the exterior sheathing line of the outermost unit.

Support is required underneath all bay and bow units. For additional support, we offer a cable support system.

Insulated platforms and brackets are not included.

HEIGHT

E-Series  
Bay & Bow Windows

# 45° Double-Hung Angle Bay Window Sizes

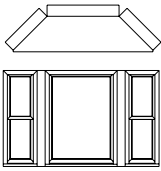

		WIDTH				
		45 Degree Double-Hung Angle Bay Units				
Rough Opp.		5'-11 1/16"	6'-1 1/16"	6'-3 1/16"	6'-11 1/16"	7'-11 1/16"
		1'-8" Wide Flanker Units				
		3'-0" Center	3'-2" Center	3'-4" Center	4'-0" Center	5'-0" Center
4'-0 1/2"		1840/3040/1840	1840/3240/1840	1840/3440/1840	1840/4040/1840	1840/5040/1840
4'-6 1/2"		1846/3046/1846	1846/3246/1846	1846/3446/1846	1846/4046/1846	1846/5046/1846
4'-9 1/2"		1849/3049/1849	1849/3249/1849	1849/3449/1849	1849/4049/1849	1849/5049/1849
5'-0 1/2"		1850/3050/1850	1850/3250/1850	1850/3450/1850	1850/4050/1850	1850/5050/1850
5'-1 1/2"		1851/3051/1851	1851/3251/1851	1851/3451/1851	1851/4051/1851	1851/5051/1851
5'-6 1/2"		1856/3056/1856	1856/3256/1856	1856/3456/1856	1856/4056/1856	1856/5056/1856
6'-0 1/2"		1860/3060/1860	1860/3260/1860	1860/3460/1860	1860/4060/1860	1860/5060/1860
Projection		1'-3 11/16"	1'-3 11/16"	1'-3 11/16"	1'-3 11/16"	1'-3 11/16"
		2'-0" Wide Flanker Units				
		3'-0" Center	3'-2" Center	3'-4" Center	4'-0" Center	5'-0" Center
4'-0 1/2"		2040/3040/2040	2040/3240/2040	2040/3440/2040	2040/4040/2040	2040/5040/2040
4'-6 1/2"		2046/3046/2046	2046/3246/2046	2046/3446/2046	2046/4046/2046	2046/5046/2046
4'-9 1/2"		2049/3049/2049	2049/3249/2049	2049/3449/2049	2049/4049/2049	2049/5049/2049
5'-0 1/2"		2050/3050/2050	2050/3250/2050	2050/3450/2050	2050/4050/2050	2050/5050/2050
5'-1 1/2"		2051/3051/2051	2051/3251/2051	2051/3451/2051	2051/4051/2051	2051/5051/2051
5'-6 1/2"		2056/3056/2056	2056/3256/2056	2056/3456/2056	2056/4056/2056	2056/5056/2056
6'-0 1/2"		2060/3060/2060	2060/3260/2060	2060/3460/2060	2060/4060/2060	2060/5060/2060
Projection		1'-6 1/2"	1'-6 1/2"	1'-6 1/2"	1'-6 1/2"	1'-6 1/2"
		2'-4" Wide Flanker Units				
		3'-0" Center	3'-2" Center	3'-4" Center	4'-0" Center	5'-0" Center
4'-0 1/2"		2440/3040/2440	2440/3240/2440	2440/3440/2440	2440/4040/2440	2440/5040/2440
4'-6 1/2"		2446/3046/2446	2446/3246/2446	2446/3446/2446	2446/4046/2446	2446/5046/2446
4'-9 1/2"		2449/3049/2449	2449/3249/2449	2449/3449/2449	2449/4049/2449	2449/5049/2449
5'-0 1/2"		2450/3050/2450	2450/3250/2450	2450/3450/2450	2450/4050/2450	2450/5050/2450
5'-1 1/2"		2451/3051/2451	2451/3251/2451	2451/3451/2451	2451/4051/2451	2451/5051/2451
5'-6 1/2"		2456/3056/2456	2456/3256/2456	2456/3456/2456	2456/4056/2456	2456/5056/2456
6'-0 1/2"		2460/3060/2460	2460/3260/2460	2460/3460/2460	2460/4060/2460	2460/5060/2460
Projection		1'-9 11/32"	1'-9 11/32"	1'-9 11/32"	1'-9 11/32"	1'-9 11/32"

### 30° Double-Hung Angle Bay Windows

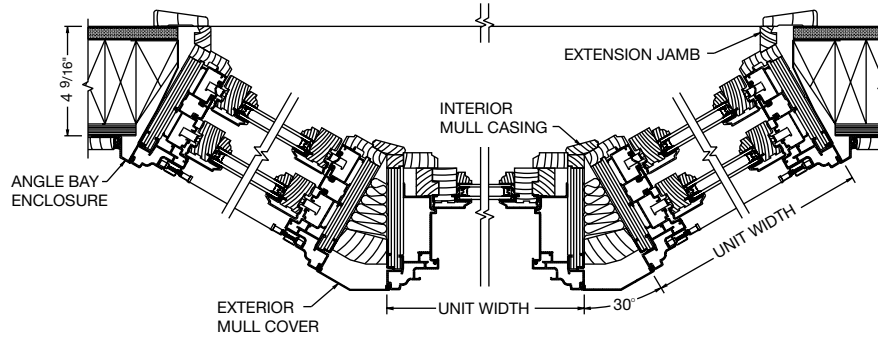

Horizontal Section

### Double-Hung Angle Bay Windows

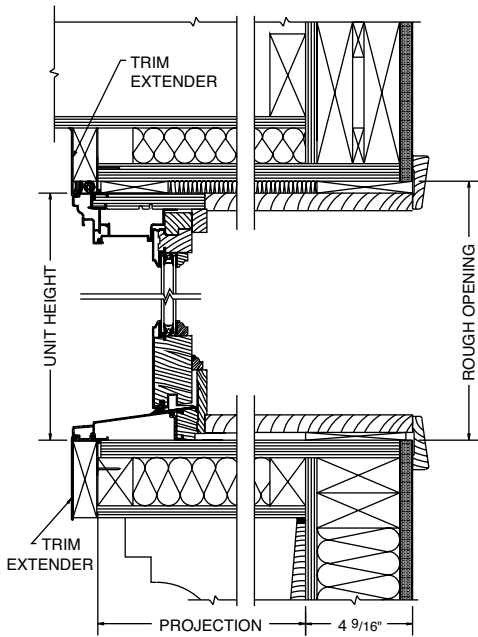

Vertical Section

### 45° Double-Hung Angle Bay Windows

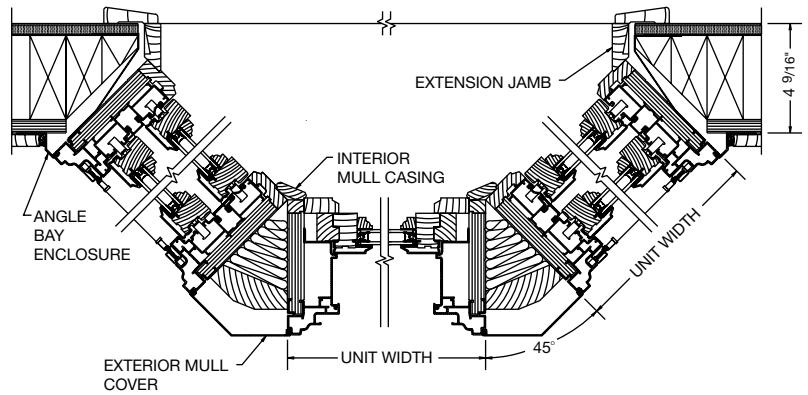

Horizontal Section

Shown with ovolo (colonial) glass stops.

# Gliding Windows

Functionality is the key to our gliding window. Efficient space utilization and sleek lines make this window the right choice for that tight, hard-to-manage space. With two or three sash systems all in one frame and discreet hardware creating clear, unobstructed views, these windows offer a cost-effective design with modern efficiencies.

---

<b>Gliding Overview .....</b>	<b>94</b>
Sizing	
Gliding 2-Sash .....	<b>96</b>
Gliding 3-Sash .....	<b>96</b>
Details .....	<b>97</b>
Installation Materials .....	<b>154</b>
Product Performance .....	<b>158</b>





E-Series gliding windows with prefinished pine interiors.

# Gliding Windows

---



## Frame & Sash

❶ Select wood components are kiln dried and treated with water/insect repellent and preservative. Interior wood surfaces are available in pine, mixed grain douglas fir, cherry, hickory, mahogany,\* maple, oak, walnut, alder or vertical grain Douglas fir. Interior surfaces are available unfinished or factory primed. Optional factory-applied finishes are available in a variety of stain and paint options.

❷ Wood components are fitted with aluminum extrusions on the exterior. 50 exterior colors that meet AAMA 2604 and 2605 specifications are available, as well as custom colors. Also available is a selection of seven exterior anodized options.

## Glazing

❸ High-performance Low-E4\* glass with a low-conductivity spacer. Tinted, clear dual-pane, high-altitude glass and other special glazing options are available.

❹ Glass is fixed in place from the interior with wood stops that can be removed for easy reglazing if necessary. Glass stops are available in ovolo (colonial) or contemporary profiles.

## Weatherstrip

Compression foam-filled bulb weatherstrip is applied on the sill for maximum resistance to water and air infiltration. Outside and inside sash are sealed with a compression bulb weatherstrip at the meeting stile.

## Head & Sill Track

❺ The frame consists of a rigid vinyl head and sill track. The compression-style head track helps create a positive seal between the sash and frame.

## Hardware



❻ Sash locks and keepers give a slim, more traditional design and allow easy opening.

Sash locks are available in finishes of bronze, polished brass, gold, white, black, antique brass, pewter, oil rubbed bronze, satin chrome and bright chrome.

Slim Line sash pulls allow easy operation and do not interfere with window coverings.

Sash pulls are available in finishes of bronze, white, black and gold. Optional polished brass plated finish also available.

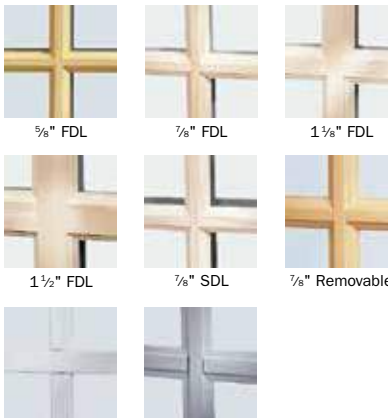
## Features & Options

6 <i>Sash Locks</i>	7 <i>Insect Screens</i>	8 <i>Grilles</i>
		
<p><i>Slim Line Sash Pulls</i></p> 		<p>FDL = Full Divided Light*          SDL = Simulated Divided Light*          Removable = Removable interior wood grilles          Flat = Finelight™ grilles-between-the-glass          Contoured = Finelight grilles-between-the-glass</p>

### Window Anchorage

Vinyl installation flanges are pre-applied into a kerf on the frame exterior to facilitate installation. Optional aluminum flanges or metal installation clips are available.

### 7 Insect Screens

Charcoal fiberglass screen mesh fits into an aluminum frame in all 50 exterior colors. Aluminum screen mesh is available as an option.

TruScene® insect screens available in all 50 exterior colors and seven anodized finishes.

See page 24 for more information on our insect screen options.

### 8 Grilles

**Full Divided Light.** Permanent interior and exterior grilles with grille spacer bars between two panes of glass. Available in 5/8", 7/8", 1 1/8", 1 1/2" or 2 1/4" widths and ovolo or contemporary profiles.

**Simulated Divided Light.** Permanent exterior and interior grilles without grille spacer bars. Available in 5/8", 7/8", 1 1/8", 1 1/2" or 2 1/4" widths and ovolo or contemporary profiles.

**Finelight™ Grilles-Between-the-Glass.** Available in 5/8" flat or 1" contoured aluminum profiles. Two-tone colors of pebble tan/colony white, sierra bronze/colony white or forest green/colony white are available on the 1" profile.

### Removable interior wood grilles.

Removable interior wood grilles are available in a 7/8" width and ovolo or contemporary profiles. Optional surround for removable grille and permanent exterior grilles also available.

\* FDL & SDL grille options also available in 2 1/4" width and in contemporary profile. See page 22 for more information. Oil rubbed bronze is a "living" finish that will change with time and use.

Printing limitations prevent exact finish replication. Please see your Andersen supplier for actual finish samples.

## 2-Sash Gliding Window Sizes

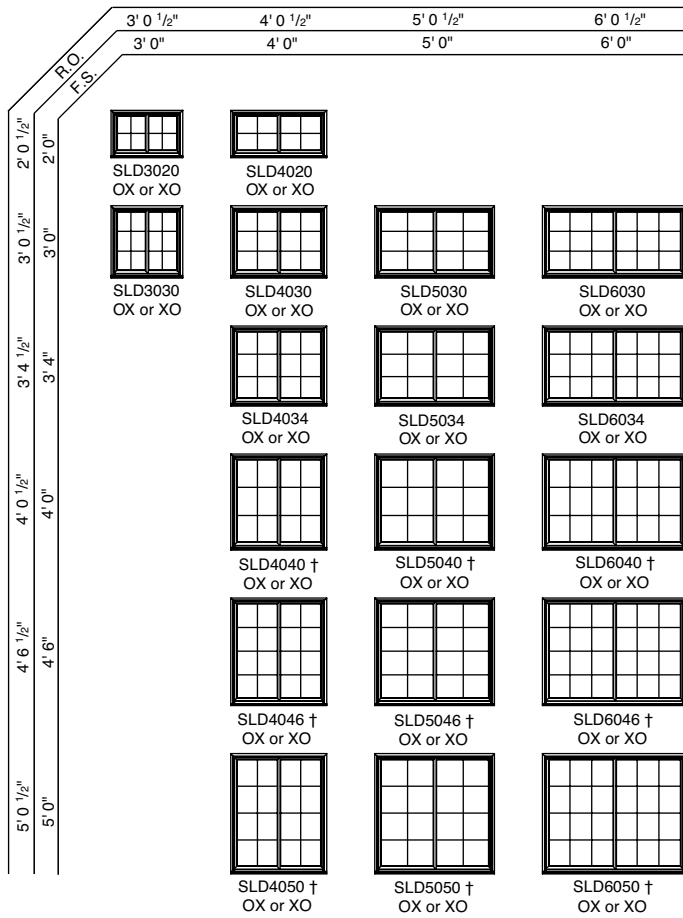

## 3-Sash Gliding Window Sizes

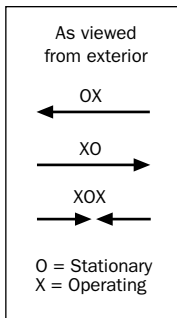
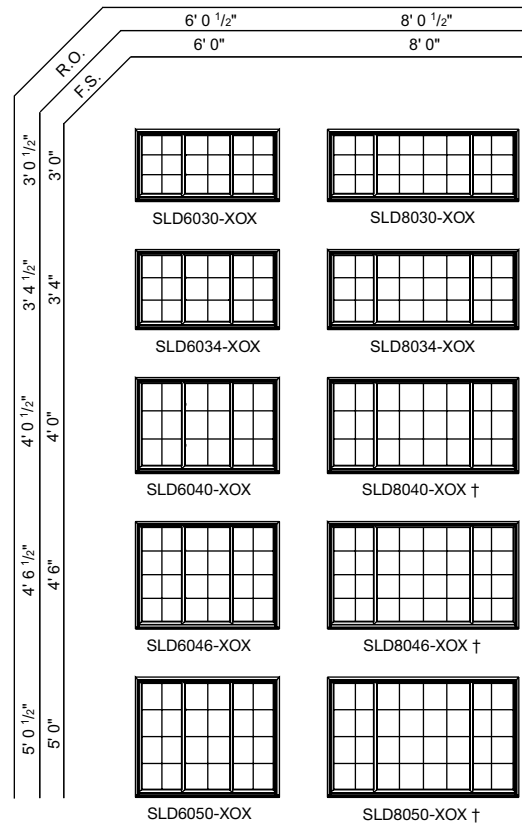

### NOTES

† These units meet or exceed the following dimensions: Clear Opening Area 5.7 sq. ft., Clear Opening Width 20", Clear Opening Height 24" and 44" maximum floor to sill height (with standard 6'10-1/2" structural header height). See your local code official for requirements in your area.

3-sash gliding units use 2'0" operating sash as a standard. Additional sash ratios also available.

If glass is positioned within 18" of the finished floor, safety/tempered glass may be required. Local codes may differ. Verify tempered glass requirements with your local building code official.

Use structural joining material when necessary or required by code.

The light patterns illustrated apply to rectangular removable interior wood grilles, Full Divided Light, Simulated Divided Light, Decorelle 100, 150 and 400 and Finelight™ Grilles-Between-the-Glass. All removable interior wood grilles will be installed in the units unless otherwise specified.

For a metric conversion in millimeters, multiply dimensions in inches by 25.4.

## 2-Sash Gliding Windows

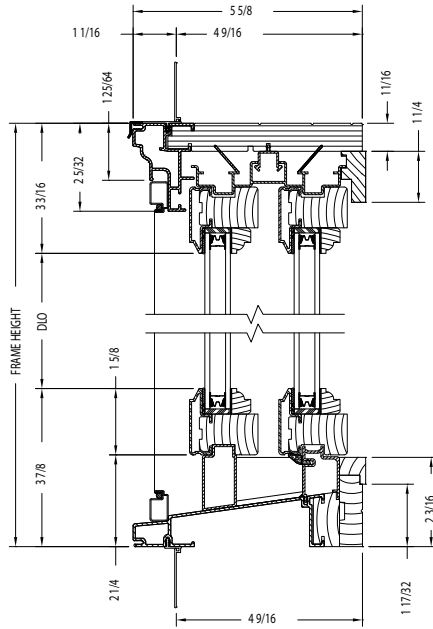

Vertical Section

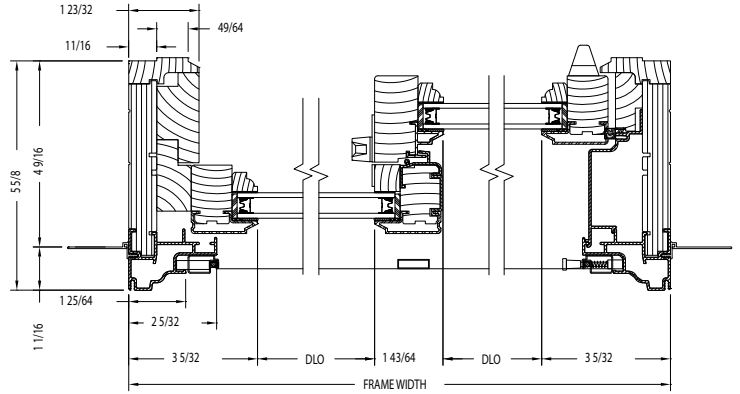

Horizontal Section

Shown with ovolo (colonial) glass stops.

## 3-Sash Gliding Windows

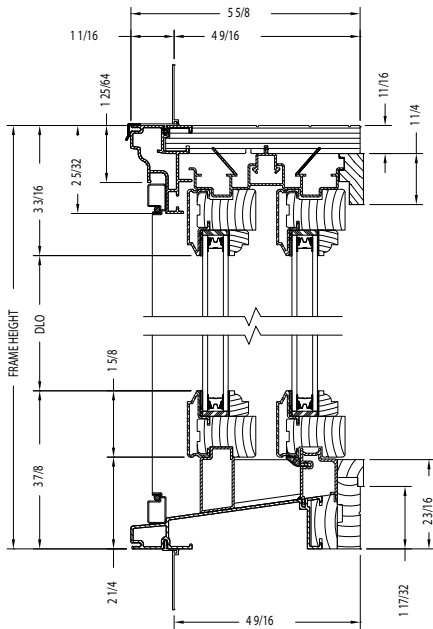

Vertical Section

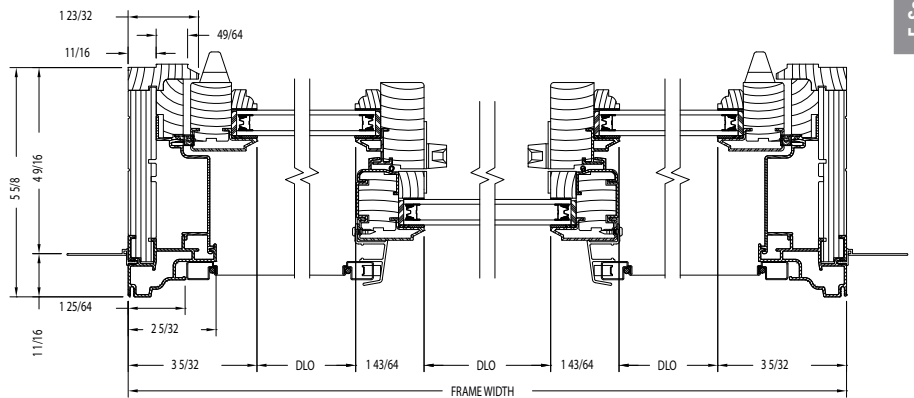

Horizontal Section

Shown with ovolo (colonial) glass stops.

# Specialty Windows

Our made-to-order philosophy lets you be creative with your look. Design your very own window using basic or unique shapes and add decorative glass for a creative accent. Our specialty profiles even complement double-hung and casement details for ultimate design flexibility.

---

<b>Specialty Overview</b> .....	<b>100</b>
Shapes .....	<b>102</b>
Sizing	
Half Circle .....	<b>103</b>
Quarter Circle .....	<b>104</b>
Circle & Oval .....	<b>104</b>
Details .....	<b>105</b>
Installation Materials .....	<b>154</b>
Product Performance .....	<b>158</b>



E-Series right triangle windows with mahogany\* wood with cinnamon interior finish.



\* Actual wood species is either Sapele or Sipo, both non-endangered species grown in Africa, with color and characteristics similar to Central American mahoganies.

# Specialty Windows

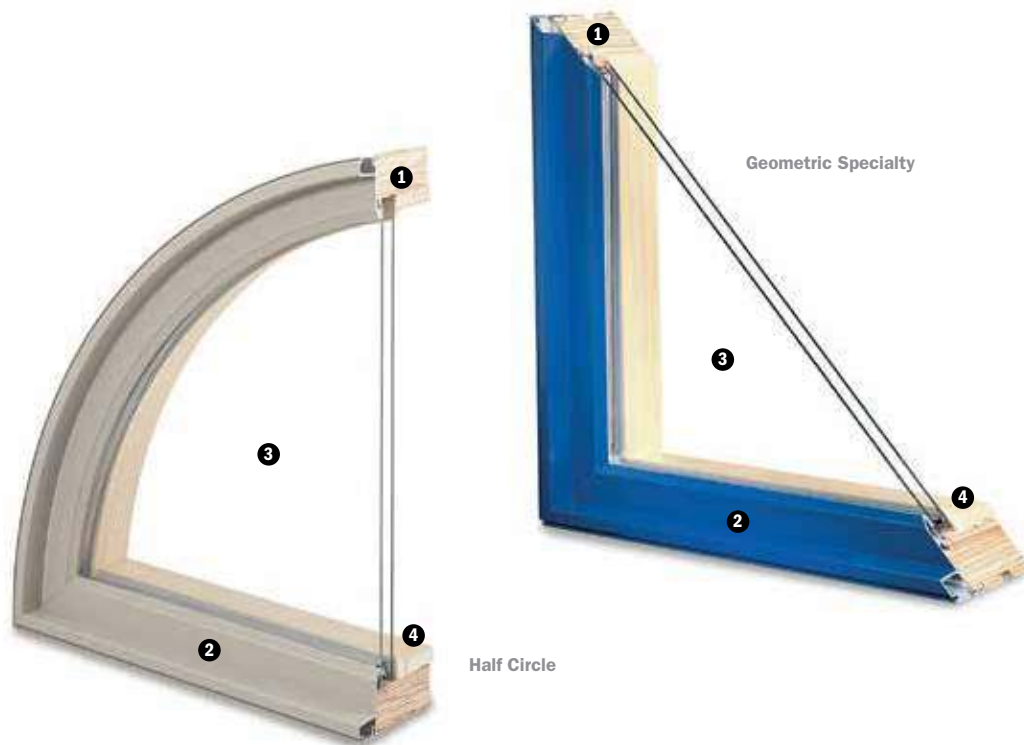

## Frame

**1** Select wood components are kiln dried and treated with water/insect repellent and preservative. Interior wood surfaces are available in pine, mixed grain douglas fir, cherry, hickory, mahogany,\* maple, oak, walnut, alder or vertical grain douglas fir. Interior surfaces are available unfinished or factory primed. Optional factory-applied finishes are available in a variety of stain and paint options.

**2** Wood components are fitted with aluminum extrusions on the exterior. 50 exterior colors that meet AAMA 2604 and 2605 specifications are available, as well as custom colors. Also available is a selection of seven exterior anodized options.

## Glazing

**3** High-Performance Low-E4\* glass with a low-conductivity spacer. Triple-pane glass, tinted, clear dual-pane, high-altitude glass and other special glazing options are available.

**4** Glass is fixed in place from the interior with wood stops that can be removed for easy reglazing if necessary. Glass stops available in ovolo (colonial) or contemporary profiles.

## Window Anchorage

Vinyl installation flanges are pre-applied into a kerf on the frame exterior to facilitate installation. Optional aluminum flanges or metal installation clips are available.

## 5 Grilles

*Full Divided Light.* Permanent interior and exterior grilles with grille spacer bars between two panes of glass. Available in  $\frac{5}{8}$ ",  $\frac{7}{8}$ ",  $1\frac{1}{8}$ ",  $1\frac{1}{2}$ " or  $2\frac{1}{4}$ " widths and ovolo (colonial) or contemporary profiles.

*Simulated Divided Light.* Permanent exterior and interior grilles without grille spacer bars. Available in  $\frac{5}{8}$ ",  $\frac{7}{8}$ ",  $1\frac{1}{8}$ ",  $1\frac{1}{2}$ " or  $2\frac{1}{4}$ " widths and ovolo or contemporary profiles.

*Finelight™ Grilles-Between-the-Glass.* Available in  $\frac{5}{8}$ " flat or 1" contoured aluminum profiles. Two-tone colors of colony white/pebble tan, colony white/sierra bronze or colony white/forest green are available on the 1" profile.



## Features & Options

<p style="text-align: center;"><b>5</b></p> <p style="text-align: center;"><i>Grilles</i></p>  <p style="text-align: center;"> <span>5/8" FDL</span>    <span>7/8" FDL</span>    <span>1 1/8" FDL</span>  <span>1 1/2" FDL</span>    <span>7/8" SDL</span>    <span>7/8" Removable</span>  <span>5/8" Flat</span>    <span>1" Contoured</span> </p> <p>FDL = Full Divided Light*          SDL = Simulated Divided Light*          Removable = Removable interior wood grille          Flat = Finelight™ grilles-between-the-glass          Contoured = Finelight grilles-between-the-glass</p>	<p style="text-align: center;"><b>6</b></p> <p style="text-align: center;"><i>Blinds-Between-the-Glass</i></p>  <p style="text-align: center;"><b>7</b></p> <p style="text-align: center;"><i>System 3 Blinds or Shades</i></p> 	 <p>Double-hung specialty frame profile is also available for half circle and geometric specialty windows.</p>
---	---	---

### *Removable interior wood grilles.*

Available in a 7/8" width, with or without surround for removable grille on rectangular shapes. A 7/8" width, without surround for removable grille is available on non-rectangular shapes. Ovolo and contemporary grille profiles available.

### **Privacy Options**

**6** *Blinds-Between-the-Glass.* A 5/8" aluminum slat blind is encased between two panes of insulated glass in a dust-free environment (rectangular shapes only). Available colors are white, tan and almond. Blind can be tilted or raised and lowered with the use of one cord. (Not all sizes are retractable.)

**7** *System 3 Blinds.* A 5/8" aluminum slat blind is mounted to an extruded aluminum blind panel and applied to the window (rectangular shapes only), creating a triple-glazed window boasting privacy and energy efficiency. Available in three colors. Blind panels are offered in white, tan, gold or an optional wood veneer to match your interior.

*System 3 Shades.* Pleated fabric shades are available in four colors to effortlessly and beautifully filter the light (rectangular shapes only). See page 25 for more details.

\* FDL & SDL grille options also available in 2 1/4" width and in contemporary profile. See page 22 for more information.

## Specialty Shapes

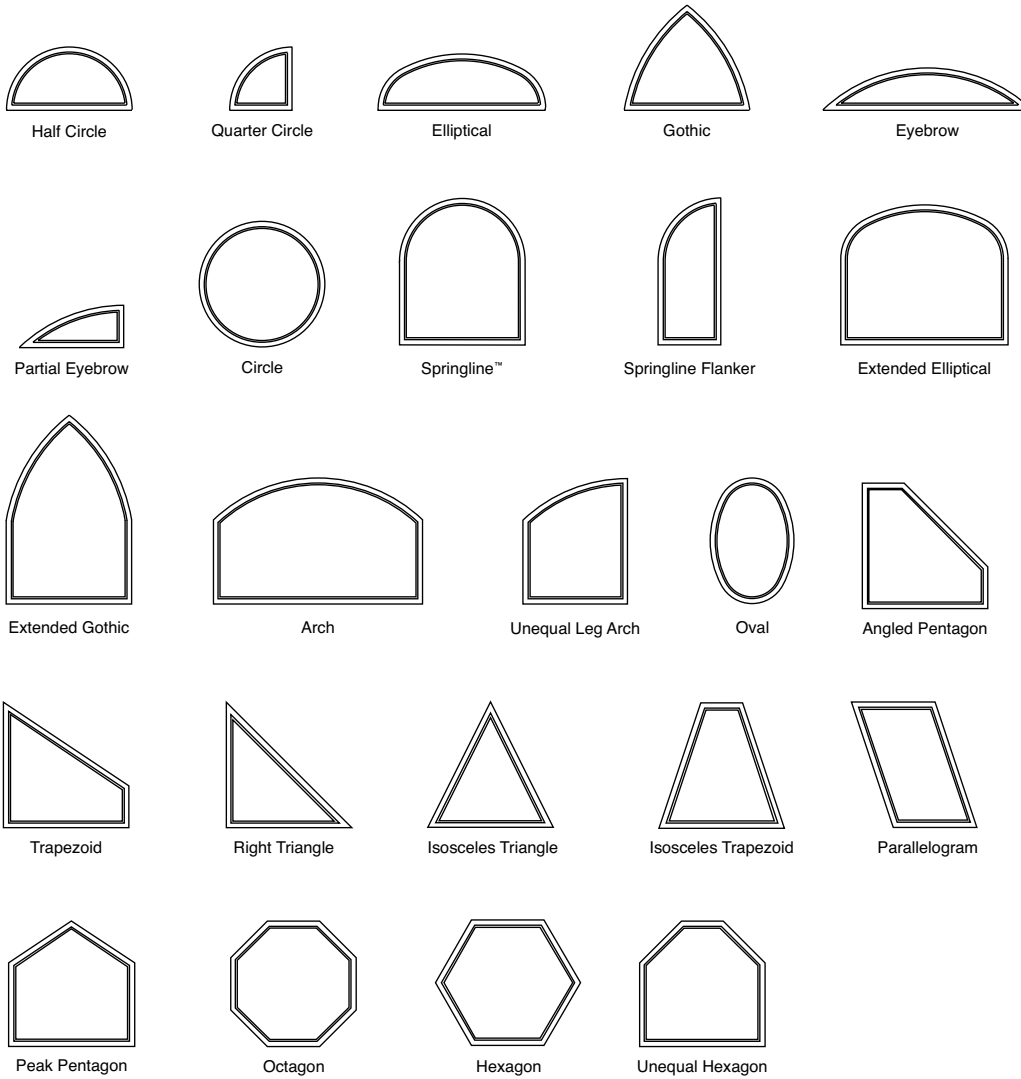

### NOTES

The following general guidelines do not apply to every specialty shape. Contact your local supplier for specific limitations of the specialty shapes shown above or about creating custom shapes beyond those shown here.

Overall unit block size should not be larger than 50 sq. ft.

Frame width and height must be between 9" and 144".

Units can only be larger than 82" in one direction.

Corners/angles cannot be less than 27°.

Standard radiuses include:

1' 0"	3' 0"	7' 0"
1' 2"	3' 1"	7' 6"
1' 3"	3' 3"	8' 0"
1' 4"	3' 4"	9' 0"
1' 6"	3' 6"	10' 7"
1' 6-23/32"	3' 9"	12' 0"
1' 8"	4' 0"	13' 8"
1' 10"	4' 6"	15' 0"
2' 0"	5' 0"	16' 0"
2' 4"	5' 6"	17' 10"
2' 6"	6' 0"	19' 8"
2' 8"	6' 6"	
2' 10-19/32"		

## Half Circle Window Sizes

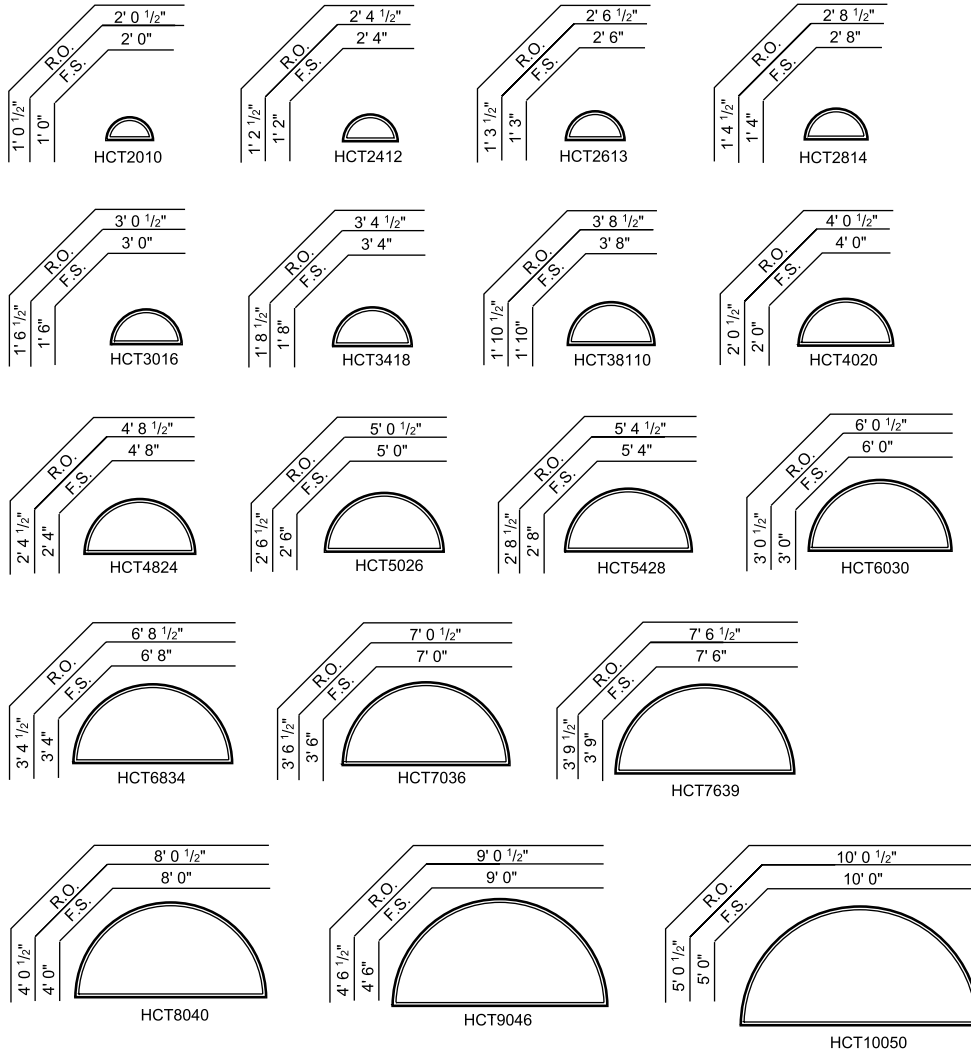

### NOTES

If glass is positioned within 18" of the finished floor, safety/tempered glass may be required. Local codes may differ. Verify tempered glass requirements with your local building code official.

Use structural joining material when necessary or required by code.

Some limitations exist for light patterns for removable interior wood grilles, Full Divided Light, Simulated Divided Light, Decorelle 100, 150 and 400 and Finelight™ Grilles-Between-the-Glass. Please contact your local supplier for more information. All wood grilles will be installed in the units unless otherwise specified.

For a metric conversion in millimeters, multiply dimensions in inches by 25.4.

## Quarter Circle Window Sizes

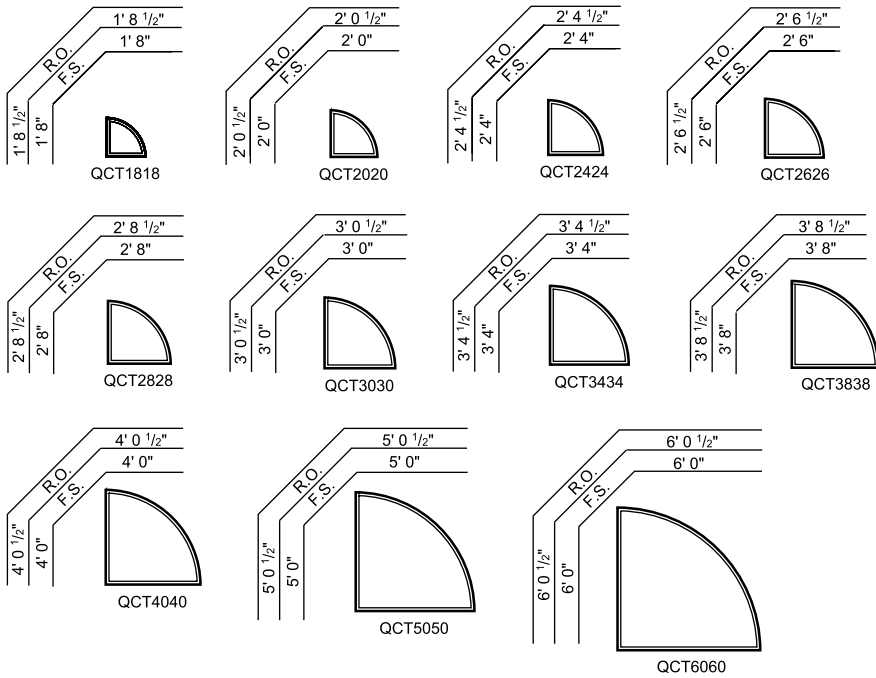

## Circle Window Sizes

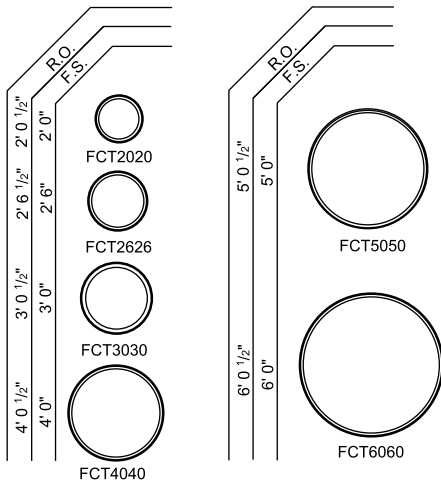

## Oval Window Sizes

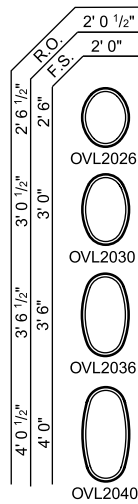

### NOTES

If glass is positioned within 18" of the finished floor, safety/tempered glass may be required. Local codes may differ. Verify tempered glass requirements with your local building code official.

Use structural joining material when necessary or required by code.

Some limitations exist for light patterns for removable interior wood grilles, Full Divided Light, Simulated Divided Light, Decorelle 100, 150 and 400 and Finelight™ Grilles-Between-the-Glass. Please contact your local supplier for more information. All wood grilles will be installed in the units unless otherwise specified.

For a metric conversion in millimeters, multiply dimensions in inches by 25.4.

Specialty Windows

Specialty

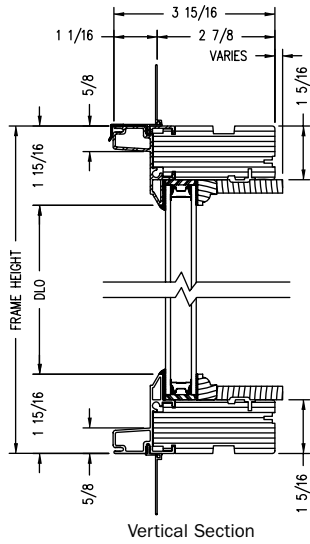

Vertical Section

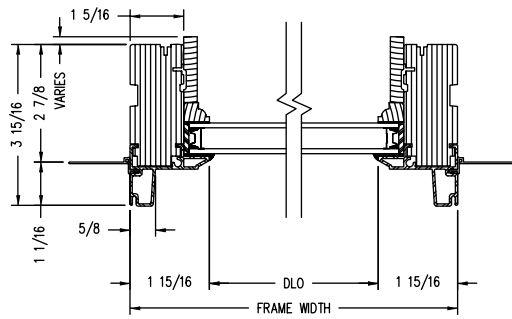

Horizontal Section

Specialty  
(Double-Hung  
Frame  
Profile)

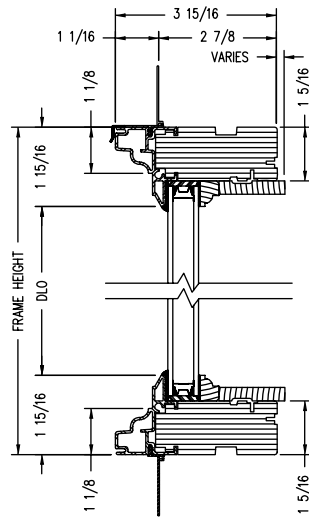

Vertical Section

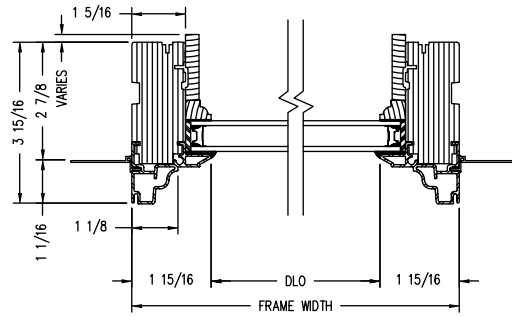

Horizontal Section

Exterior  
Glazed  
Specialty

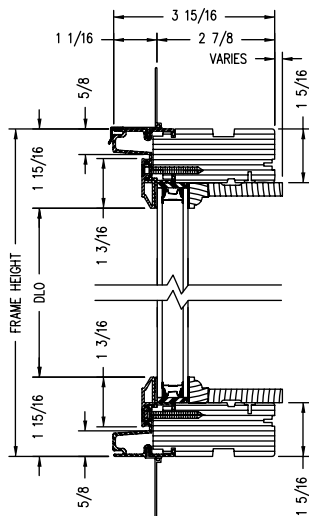

Vertical Section

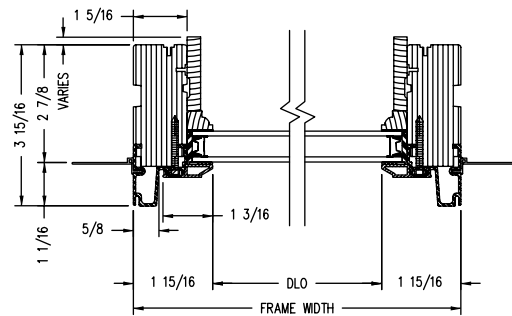

Horizontal Section

# Hinged Patio Doors

Bottom and intermediate rail options are just the start to this door's solid design. Select contemporary or French styling, go as high as 10 feet, add venting inswing or outswing sidelights or raised solid wood panel inserts and create a truly custom look.

---

<b>Hinged Overview</b> .....	<b>108</b>
Panel Labeling .....	<b>112</b>
Panel Handing .....	<b>116, 132</b>
Inswing Sizing	
Single Panel Doors .....	<b>118</b>
Two-Panel Doors .....	<b>119</b>
Sash-Set & Direct-Set Sidelights .....	<b>120</b>
Sash-Set Transoms .....	<b>121</b>
Specialty Transoms .....	<b>122</b>
Direct-Set Transoms .....	<b>123</b>
Arch Doors .....	<b>125</b>
Inswing Details .....	<b>127</b>
Outswing Sizing	
Two-Panel Doors .....	<b>133</b>
Single Panel Doors & Sash-Set Sidelights .....	<b>134</b>
Sash-Set Transoms .....	<b>135</b>
Direct-Set & Specialty Transoms .....	<b>136</b>
Arch Doors .....	<b>137</b>
Concealed Panic System Sizing .....	<b>138</b>
Outswing Details .....	<b>139</b>
Installation Materials .....	<b>154</b>
Product Performance .....	<b>158</b>





E-Series hinged inswing patio door and sidelights with white interior.

# Hinged Patio Doors

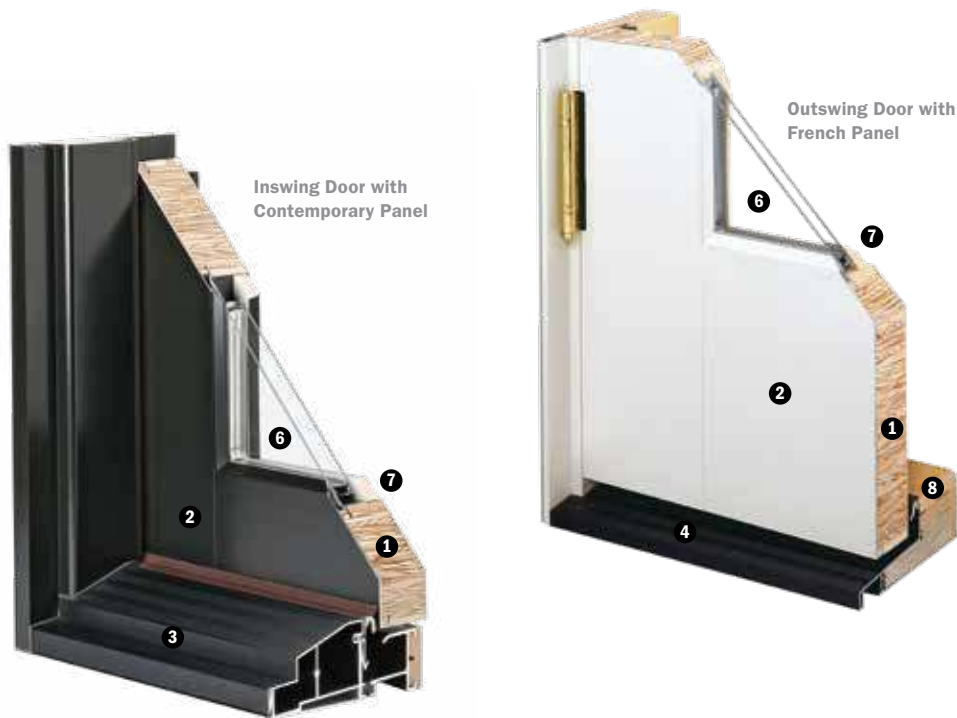

## Frame & Panel

**1** Select wood components are kiln dried and treated with water/insect repellent and preservative. Interior wood surfaces are available in pine, mixed grain Douglas fir, cherry, hickory, mahogany,\* maple, oak, walnut, alder or vertical grain Douglas fir. Interior surfaces are available unfinished or factory primed. Optional factory-applied finishes are available in a variety of stain and paint options.

**2** Wood components are fitted with aluminum extrusions on the exterior. 50 exterior colors that meet AAMA 2604 and 2605 specifications are available, as well as custom colors. Also available is a selection of seven exterior anodized options.

## Sill

**3** Premium grade aluminum inswing sill with an oak threshold. Sills have a built-in drainage channel that allows water to drain away from the interior of the door. A top plate is removable for easy channel cleaning. A polyurethane thermal barrier helps reduce heat loss. Available in clear anodized or dark bronze anodized finish.

**4** Premium grade aluminum outswing sill with oak threshold. Outswing door sill is backed with a compression foam weatherstrip. Available in clear anodized or dark bronze anodized finish.

**5** Aluminum low threshold sill available for outswing doors and inswing doors with jamb depths of 4 $\frac{1}{16}$ " and 6 $\frac{1}{16}$ ". Low threshold design provides a smooth transition from interior to exterior and is wheelchair-accessible. A polyurethane thermal barrier helps reduce heat loss. Available in dark bronze anodized finish.

## Glazing

**6** High-Performance Low-E4° glass with a low-conductivity spacer. Triple-pane glass, tinted, clear dual-pane, high-altitude glass and other special glazing options are available.

**7** Glass is fixed in place from the interior with wood stops that can be removed for easy reglazing if necessary. Glass stops available in ovolo (colonial) and contemporary profiles.

## Weatherstrip

**8** The frame perimeter consists of a high-quality foam-filled weatherstrip.

## Door Anchorage

Inswing and outswing doors receive a factory-applied vinyl installation flange with drip cap. Some inswing patio doors require an adjustable metal installation flange. Optional aluminum flanges or metal installation clips are available.

## Hardware

Autolatch® stainless steel multi-point locking system locks the panel in three locations to provide a secure, weather-resistant entry system. Some door heights lock the panel in four locations.

**9** Hinged patio door hardware is available in eight different designs to match virtually any style. Yuma®, Encino®, Anvers®, Newbury®, Covington™ and Whitmore® hardware options each feature solid, drop-forged brass for added strength, while Albany and Tribeca® hardware options are made of zinc die cast with durable powder-coated finishes. Additional hardware options such as FSB® hardware, exterior keyed locks and more are also available.

## Features & Options

<p><b>3</b> <i>4 1/16" Inswing Drainage Sill</i></p> 	<p><b>5</b> <i>Inswing Low Threshold Sill</i></p> 	<p><b>9</b> <i>FSB® Handles</i></p> 	<p><b>10</b> <i>Yale® Assure Lock®*</i></p> 
<p><b>4</b> <i>Outswing On-Floor Sill</i></p> 	<p><i>Outswing Low Threshold Sill</i></p> 		

**9**  
*Handle Sets*

							
<p><b>Yuma®</b> Distressed Bronze <b>Distressed Nickel</b></p>	<p><b>Encino®</b> <b>Distressed Bronze</b> Distressed Nickel</p>	<p><b>Covington™</b> Antique Brass <b>Bright Brass</b> Oil Rubbed Bronze</p>	<p><b>Whitmore®</b> <b>Antique Brass</b> Bright Brass Oil Rubbed Bronze Satin Nickel</p>	<p><b>Anvers®</b> Bright Brass Oil Rubbed Bronze <b>Satin Nickel</b></p>	<p><b>Newbury®</b> Antique Brass Bright Brass Brushed Chrome <b>Oil Rubbed Bronze</b> Polished Chrome Satin Nickel</p>	<p><b>Albany</b> Black <b>Gold Dust</b> Stone White</p>	<p><b>Tribeca®</b> Stone <b>White</b></p>

<p><b>11</b> <i>Temporary Construction Handle</i></p> 	<p><b>12</b> <i>Heavy-Duty Commercial Grade Hinges</i></p> 
---	---

**10** Monitor, lock and unlock from anywhere with the Yale Assure Lock. The sleek keyless lock includes Bluetooth® technology for key-free unlocking and is compatible with Z-Wave® for integration with a wide range of smart home platforms.

**11** Temporary construction handle is sent with all hinged patio doors. This handle allows operation during the construction phase, protecting finished hardware from damage or jobsite theft.

**12** Heavy-duty commercial grade hinges are available in a standard finish of polished brass or optional finishes of limited lifetime brass, antique brass, oil rubbed bronze, pewter, satin chrome, bright chrome, white, black, stainless steel or gold dust to match your handle set. Hinges are complete with matching screws. An innovative hinge shimming system allows for minor adjustments.

\* Available on select hinged doors, see your Andersen supplier for details.  
Tribeca and Albany hardware are zinc die cast with powder-coated durable finish. Other hardware is solid forged brass. Mix-and-match interior and exterior style and finish options are available.  
Distressed bronze and oil rubbed bronze are "living" finishes that will change with time and use.  
Bright brass and satin nickel finishes feature a 10-year limited warranty.  
All marks where denoted are trademarks of their respective owners.  
Printing limitations prevent exact finish replication. See your Andersen supplier for actual finish samples.

# Features & Options

12 Insect Screens	13 Grilles	14 Raised Panel Inserts
 <p>Retractable insect screen shown.</p>	 <p>5/8" FDL      7/8" FDL      1 1/8" FDL 1 1/2" FDL      7/8" SDL      7/8" Removable 5/8" Flat      1" Contoured</p> <p>FDL = Full Divided Light* SDL = Simulated Divided Light* Removable = Removable interior wood grilles Flat = Finelight™ grilles-between-the-glass Contoured = Finelight grilles-between-the-glass</p>	
<p>15 <i>Blinds-Between-the-Glass</i></p> 	<p>16 <i>Transoms</i></p> 	

## Sensors

VeriLock® sensors are unique as they detect whether the doors are locked or unlocked\*\* — a feature no other sensors can provide. See pages 27 and 29 for Smart Home options.

## 12 Insect Screens

**Retractable Insect Screens.** Concealed, retractable insect screen has charcoal fiberglass screen mesh. Available for inswing single or double door units. Insect screen rolls out when needed and retracts into concealed housing when not in use. Available in 50 exterior colors.

Retractable insect screens for outswing doors are field applied to the interior of the door. Available in five colors including white, almond, desert sand, bronze and black.

### Hinged Insect Screens (Inswing only).

Charcoal fiberglass screen mesh fits into an aluminum frame in 50 exterior colors. Provided with a black lockable latch and

automatic closer for smooth operation. Available in single or multiple door units. Aluminum screen mesh is also available.

### Top-Hung Gliding Insect Screens

(Inswing Center Post Door). Charcoal fiberglass screen mesh fits into an aluminum frame available in 50 exterior colors. Aluminum screen mesh is also available as an option.

## 13 Grilles

**Full Divided Light.** Permanent interior and exterior grilles with grille spacer bars between two panes of glass. Available in 5/8", 7/8", 1 1/8", 1 1/2" or 2 1/4" widths and ovolo (colonial) or contemporary profiles.

**Simulated Divided Light.** Permanent exterior and interior grilles without grille spacer bars. Available in 5/8", 7/8", 1 1/8", 1 1/2" or 2 1/4" widths and ovolo or contemporary profiles.

## Finelight™ Grilles-Between-the-Glass.

Available in 5/8" flat or 1" contoured aluminum profiles. Two-tone colors of pebble tan/colony white, sierra bronze/colony white or forest green/colony white are available on the 1" profile.

## Removable interior wood grilles.

Removable interior wood grilles are available in a 7/8" width and ovolo or contemporary profiles. Optional surround for removable grille and permanent exterior grilles also available.

## 14 Raised Panel Inserts

Available in 1/2" and 3/4" light options. Real wood, available in all wood species, makes up the interior panel insert. The exterior panel insert is made of formed aluminum cladding and is available in all 50 exterior colors and any custom color.

The raised panel inserts are based on the standard 8" bottom rail with 4 11/16" stiles. Available in nine widths to match standard door panel sizes.

## Features & Options



Additional intermediate rail options available allowing glass lights to be placed above and below the intermediate rail.

### 15 Privacy Options

*Blinds-Between-the-Glass.* A  $\frac{5}{16}$ " aluminum slat blind mounted between two panes of insulated glass in a dust-free environment. Available in white, tan and almond. Blinds are magnetically controlled and can be tilted or raised and lowered with one cord. (Not available on arch patio doors.)

### 16 Transoms

Available in three jamb depths to align with your inswing door jamb depth. Design is sloped for water disbursement. Inswing and outswing sash-set transoms are available with  $2\frac{3}{4}$ ",  $3\frac{1}{16}$ ",  $4\frac{1}{16}$ " and  $6\frac{1}{2}$ " stiles to match your door.

### 17 Venting Sidelights

Outswing sidelights have concealed locks and operate with our convenient folding operator handles. Interior wood-veneered insect screen can be customized to match your interior wood species and finish.

Inswing sidelights come with special hardware that locks in the center and complements the door's handle set. When the handle is activated upwards, shoot bolts engage at the head and sill for added security. Inswing sidelights feature an exterior insect screen.

### 18 Center Post Door

Allows door panels to be hinged at the center or at the jamb. Available in two jamb depths:  $4\frac{9}{16}$ " and  $6\frac{9}{16}$ ".

The center post is clad laminated veneer lumber (LVL) that provides exceptional structural integrity. A top-hung gliding insect screen is available on the inswing center post door.

### Commercial Door Panels

Available in single or double door applications. The commercial door panels have a 12" bottom rail and  $6\frac{1}{2}$ " stiles and an intermediate rail that allows for commercial hardware installation.

### 19 Concealed Panic System Door

We have created an innovative Concealed Panic System (CPS), eliminating the need for a center astragal and exposed vertical rods on double doors. This system provides a clear opening while maintaining a sleek, uncluttered interior look. The system locks at the head and sill for added security. You get the same warm, real wood interior you've come to expect from us without the unsightly clutter common to most commercial doors.

We've also aligned with Von Duprin,<sup>®</sup> the most recognized and trusted brand of commercial hardware in the window and door industry. Von Duprin, along with the Ingersoll-Rand family of brands, provides premium push bars, handle sets, closers and kick plates to make the CPS door truly innovative. Plus, our doors are factory-prepped, making installation much easier.

\* Not all sizes are retractable. See your local Andersen supplier for details.

\*\* When properly configured and maintained with a professionally installed security system and/or self-monitoring system compatible with Honeywell<sup>®</sup> 5800 controls. See your Andersen supplier for more information.

<sup>®</sup>"Von Duprin" is a registered trademark of Ingersoll-Rand Co.

# Hinged Patio Door Panel Labeling

## Door Panel Options

Andersen® E-Series offers a wide range of door styles to accommodate any home project style. Both contemporary and French panel styles are available to complement traditional or modern architecture.

Hinged Patio Door Contemporary Panels

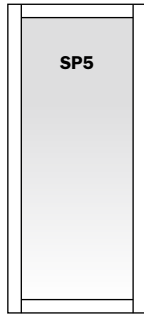

3<sup>1</sup>/<sub>16</sub>" stiles & rails

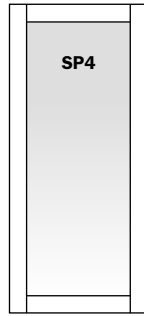

4<sup>1</sup>/<sub>16</sub>" stiles & rails

Hinged Patio Door French Panels

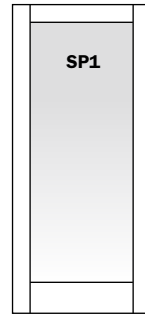

4<sup>1</sup>/<sub>16</sub>" stiles, 4<sup>1</sup>/<sub>16</sub>" top rail & 8" bottom rail

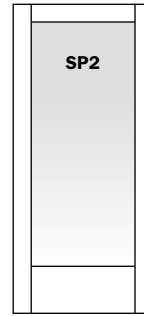

4<sup>1</sup>/<sub>16</sub>" stiles, 4<sup>1</sup>/<sub>16</sub>" top rail & 12" bottom rail

---

## Panels with 5<sup>5</sup>/<sub>16</sub>" Intermediate Rail 23<sup>1</sup>/<sub>4</sub>" from Bottom of Panel

---

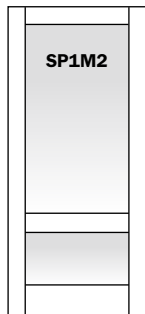

4<sup>1</sup>/<sub>16</sub>" stiles, 4<sup>1</sup>/<sub>16</sub>" top rail & 8" bottom rail

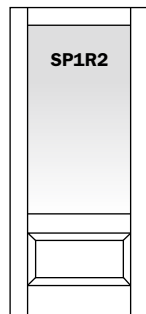

4<sup>1</sup>/<sub>16</sub>" stiles, 4<sup>1</sup>/<sub>16</sub>" top rail, 8" bottom rail & raised panel insert

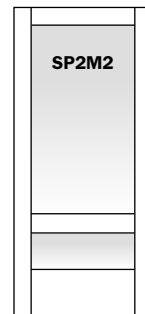

4<sup>1</sup>/<sub>16</sub>" stiles, 4<sup>1</sup>/<sub>16</sub>" top rail & 12" bottom rail

---

## Panels with 5<sup>5</sup>/<sub>16</sub>" Intermediate Rail 35" from Bottom of Panel

---

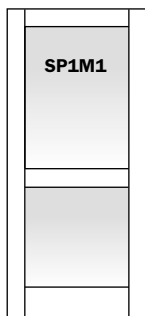

4<sup>1</sup>/<sub>16</sub>" stiles, 4<sup>1</sup>/<sub>16</sub>" top rail & 8" bottom rail

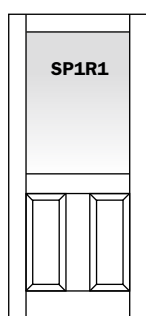

4<sup>1</sup>/<sub>16</sub>" stiles, 4<sup>1</sup>/<sub>16</sub>" top rail, 8" bottom rail & raised panel insert

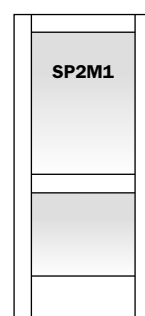

4<sup>1</sup>/<sub>16</sub>" stiles, 4<sup>1</sup>/<sub>16</sub>" top rail & 12" bottom rail

## Sidelight Panels

Contemporary Panel

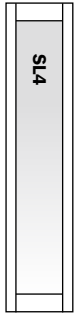

2 3/4" stiles  
4 1/16" top rail  
& bottom rail

French Panels

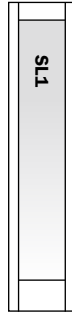

2 3/4" stiles  
4 1/16" top rail  
8" bottom rail

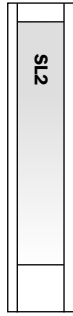

2 3/4" stiles  
4 1/16" top rail  
12" bottom rail

5 5/16" Intermediate Rail 23 3/4" from Bottom of Panel

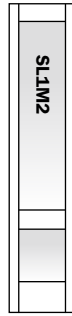

2 3/4" stiles  
4 1/16" top rail  
8" bottom rail

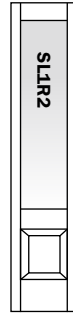

2 3/4" stiles  
4 1/16" top rail  
8" bottom rail &  
raised panel insert

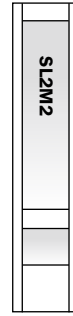

2 3/4" stiles  
4 1/16" top rail  
12" bottom rail

5 5/16" Intermediate Rail 35" from Bottom of Panel

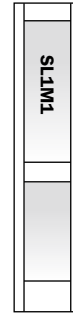

2 3/4" stiles  
4 1/16" top rail  
8" bottom rail



2 3/4" stiles  
4 1/16" top rail  
8" bottom rail &  
raised panel insert

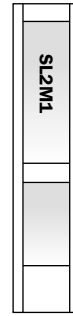

2 3/4" stiles  
4 1/16" top rail  
12" bottom rail

## Transom Panels



2 3/4" stiles & rails



2 3/4" stiles & 4 1/16" rails

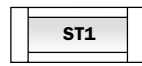

4 1/16" stiles & 2 3/4" rails

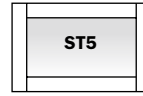

3 1/16" stiles & rails

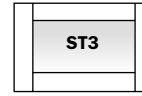

4 1/16" stiles & rails

## Commercial Door, Sidelight & Transom Panels\*

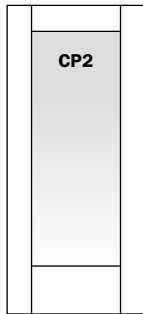

6 1/2" stiles, 6 1/2" top rail  
& 12" bottom rail

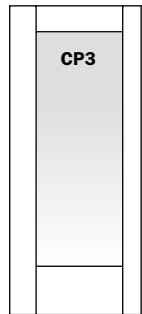

6 1/2" stiles, 6 1/2" top rail  
& 12" bottom rail  
Concealed Panic System

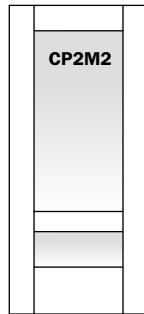

6 1/2" stiles, 6 1/2" top rail  
& 12" bottom rail with  
5 5/16" intermediate rail  
23 3/4" from bottom of panel

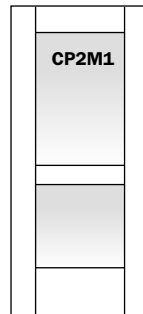

6 1/2" stiles, 6 1/2" top rail  
& 12" bottom rail with  
5 5/16" intermediate rail  
35" from bottom of panel

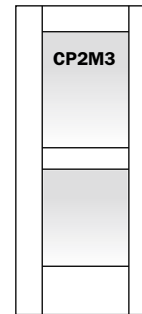

6 1/2" stiles, 6 1/2" top rail  
& 12" bottom rail with  
5 5/16" intermediate rail  
39" from bottom of panel

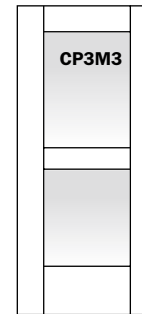

6 1/2" stiles, 6 1/2" top rail  
& 12" bottom rail with  
5 5/16" intermediate rail  
39" from bottom of panel  
Concealed Panic System

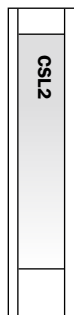

2 3/4" stiles,  
6 1/2" top rail &  
12" bottom rail

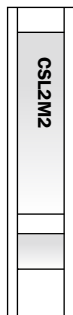

2 3/4" stiles, 6 1/2" top rail  
& 12" bottom rail with  
5 5/16" intermediate rail  
23 3/4" from bottom of panel

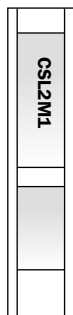

2 3/4" stiles, 6 1/2" top rail  
& 12" bottom rail with  
5 5/16" intermediate rail  
35" from bottom of panel

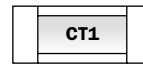

6 1/2" stiles & 2 3/4" rails

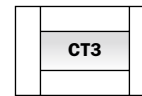

6 1/2" stiles & rails



2 3/4" stiles & 6 1/2" rails

\* Also available for residential applications.

## Arch Panels

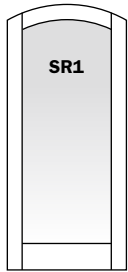

4 1/16" stiles, 4 1/16" top rail  
& 8" bottom rail

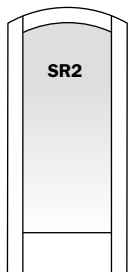

4 1/16" stiles, 4 1/16" top rail  
& 12" bottom rail

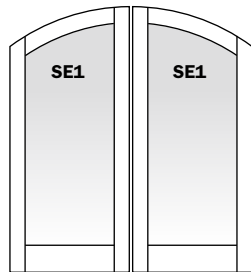

4 1/16" stiles, 4 1/16" top rail  
& 8" bottom rail

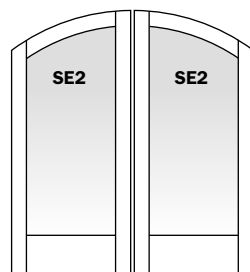

4 1/16" stiles, 4 1/16" top rail  
& 12" bottom rail

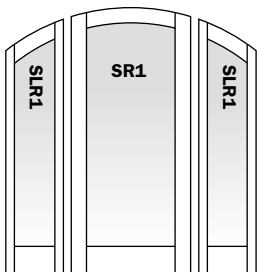

2 3/4" stiles 4 1/16" stiles  
4 1/16" top rail 4 1/16" top rail  
8" bottom rail 8" bottom rail

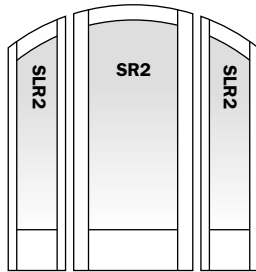

2 3/4" stiles 4 1/16" stiles  
4 1/16" top rail 4 1/16" top rail  
12" bottom rail 12" bottom rail

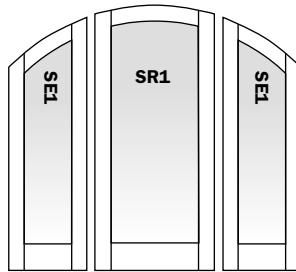

4 1/16" stiles 4 1/16" stiles  
4 1/16" top rail 4 1/16" top rail  
8" bottom rail 8" bottom rail

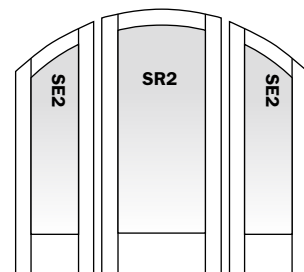

4 1/16" stiles 4 1/16" stiles  
4 1/16" top rail 4 1/16" top rail  
12" bottom rail 12" bottom rail

## Arch Panels with 5 5/16" Intermediate Rail 23 1/4" from Bottom of Panel

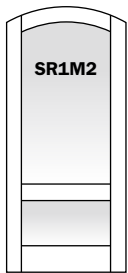

4 1/16" stiles, 4 1/16" top rail  
& 8" bottom rail

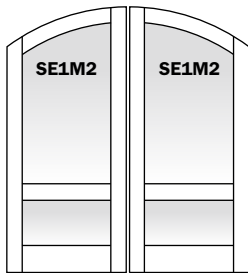

4 1/16" stiles, 4 1/16" top rail  
& 8" bottom rail

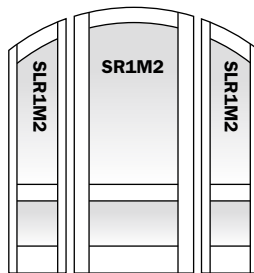

2 3/4" stiles 4 1/16" stiles  
4 1/16" top rail 4 1/16" top rail  
8" bottom rail 8" bottom rail

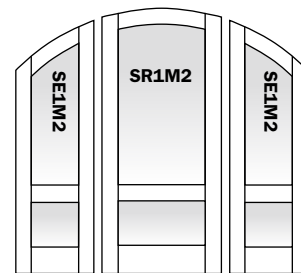

4 1/16" stiles 4 1/16" stiles  
4 1/16" top rail 4 1/16" top rail  
8" bottom rail 8" bottom rail

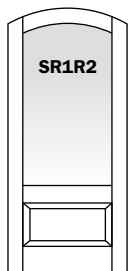

4 1/16" stiles, 4 1/16" top rail,  
8" bottom rail & raised panel insert

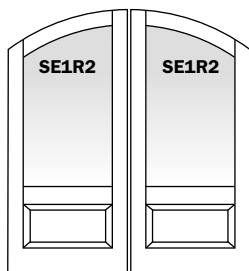

4 1/16" stiles, 4 1/16" top rail,  
8" bottom rail & raised panel inserts

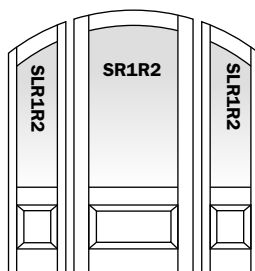

2 3/4" stiles, 4 1/16" stiles,  
4 1/16" top rail, 4 1/16" top rail,  
8" bottom rail & raised panel insert  
8" bottom rail & raised panel insert

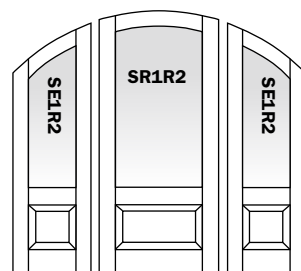

4 1/16" stiles, 4 1/16" stiles,  
4 1/16" top rail, 4 1/16" top rail,  
8" bottom rail & raised panel insert  
8" bottom rail & raised panel insert



**Arch Panels with 5 5/16" Intermediate Rail 23 1/4" from Bottom of Panel (Continued)**

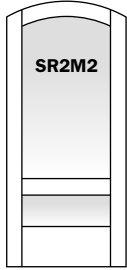

4 1/16" stiles, 4 1/16" top rail  
& 12" bottom rail

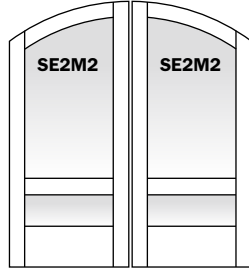

4 1/16" stiles, 4 1/16" top rail  
& 12" bottom rail

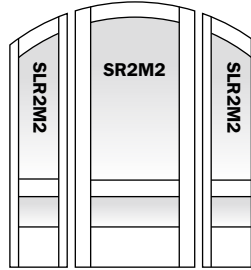

2 3/8" stiles 4 1/16" stiles  
4 1/16" top rail 4 1/16" top rail  
12" bottom rail 12" bottom rail

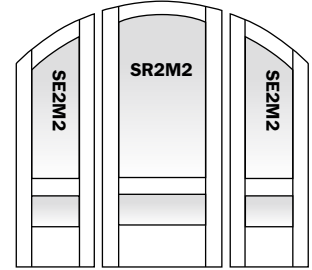

4 1/16" stiles 4 1/16" stiles  
4 1/16" top rail 4 1/16" top rail  
12" bottom rail 12" bottom rail

**Arch Panels with 5 5/16" Intermediate Rail 35" from Bottom of Panel**

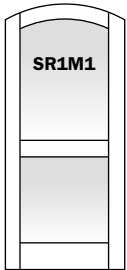

4 1/16" stiles, 4 1/16" top rail  
& 8" bottom rail

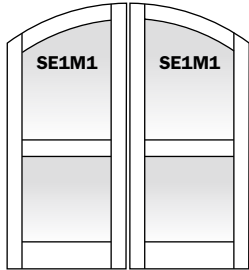

4 1/16" stiles, 4 1/16" top rail  
& 8" bottom rail

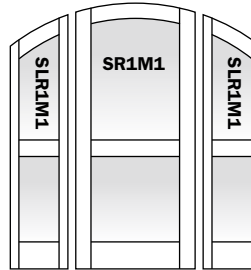

2 3/8" stiles 4 1/16" stiles  
4 1/16" top rail 4 1/16" top rail  
8" bottom rail 8" bottom rail

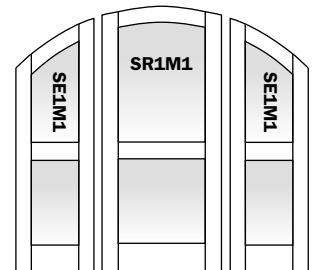

4 1/16" stiles 4 1/16" stiles  
4 1/16" top rail 4 1/16" top rail  
8" bottom rail 8" bottom rail

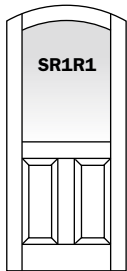

4 1/16" stiles, 4 1/16" top rail,  
8" bottom rail &  
raised panel insert

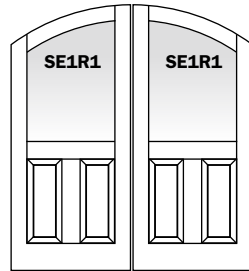

4 1/16" stiles, 4 1/16" top rail,  
8" bottom rail &  
raised panel inserts

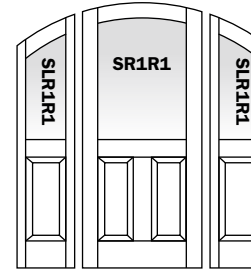

2 3/8" stiles, 4 1/16" stiles,  
4 1/16" top rail, 4 1/16" top rail,  
8" bottom rail 8" bottom rail  
& raised panel insert & raised panel  
insert

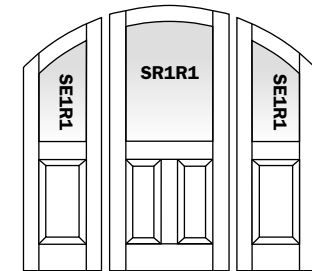

4 1/16" stiles, 4 1/16" stiles,  
4 1/16" top rail, 4 1/16" top rail,  
8" bottom rail 8" bottom rail  
& raised panel insert & raised panel  
insert

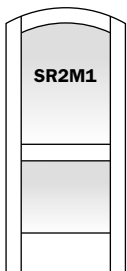

4 1/16" stiles, 4 1/16" top rail  
& 12" bottom rail

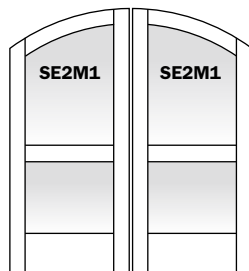

4 1/16" stiles, 4 1/16" top rail  
& 12" bottom rail

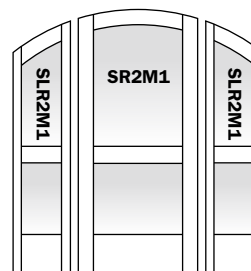

2 3/8" stiles 4 1/16" stiles  
4 1/16" top rail 4 1/16" top rail  
12" bottom rail 12" bottom rail

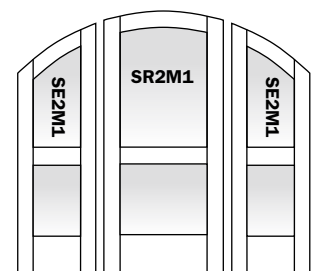

4 1/16" stiles 4 1/16" stiles  
4 1/16" top rail 4 1/16" top rail  
12" bottom rail 12" bottom rail

# Hinged Patio Door Handing

The door handing and order designation noted below and on the opposite page is consistent with the handing of other Andersen® doors and is used throughout the remainder of the hinged patio doors section.

## Identification

All hinged doors are **viewed from the exterior**. From left to right, choose stationary, active or passive, then choose hinging.

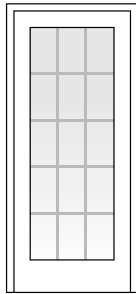

**Stationary Panel**  
Non-operating panel.

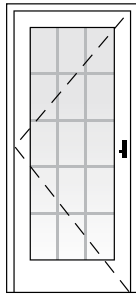

**Left Hinged**  
Hinges mounted on the left side of the panel.

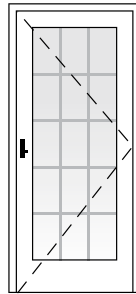

**Right Hinged**  
Hinges mounted on the right side of the panel.

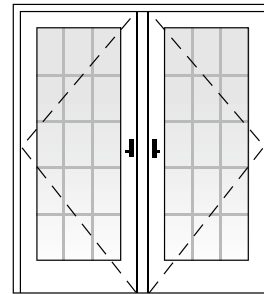

**Active Panel**   **Passive Panel**  
The operating panel most often used.   The operating panel with astragal attached.

## Hinged Patio Doors — Inswing

### Handing Options

#### Single Door

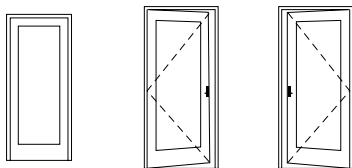

**S**  
Stationary Panel

**A L**  
Active Panel  
Left Hinged

**A R**  
Active Panel  
Right Hinged

#### Double Door

(shown as APLR)

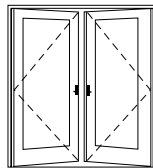

**A P L R**  
Active Panel   Left Hinged  
Passive Panel   Right Hinged

#### Center Post Door

(shown as hinged off astragal)

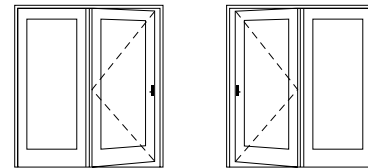

**S A L**  
Stationary Panel   Left Hinged  
Active Panel

**A S R**  
Active Panel   Right Hinged  
Stationary Panel

Order Designation Description	
	As Viewed From Exterior
Single Door	S
	AL
	AR
Double Door	PALR
	APLR
	SS
Center Post Door – Hinged Off Jamb	SAR
	ASL
Center Post Door – Hinged Off Astragal	SAL
	ASR

## Hinged Patio Doors — Outswing

### Handing Options

#### Single Door

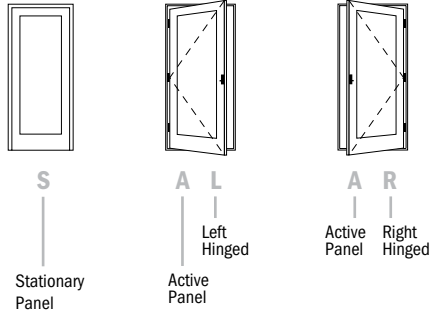

#### Double Door

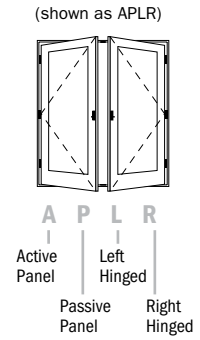

Order Designation Description	
	As Viewed From Exterior
Single Door	S
	AR
	AL
Double Door	APLR
	PALR
	SS

# Single Hinged Inswing Patio Door & Sidelight Sizes

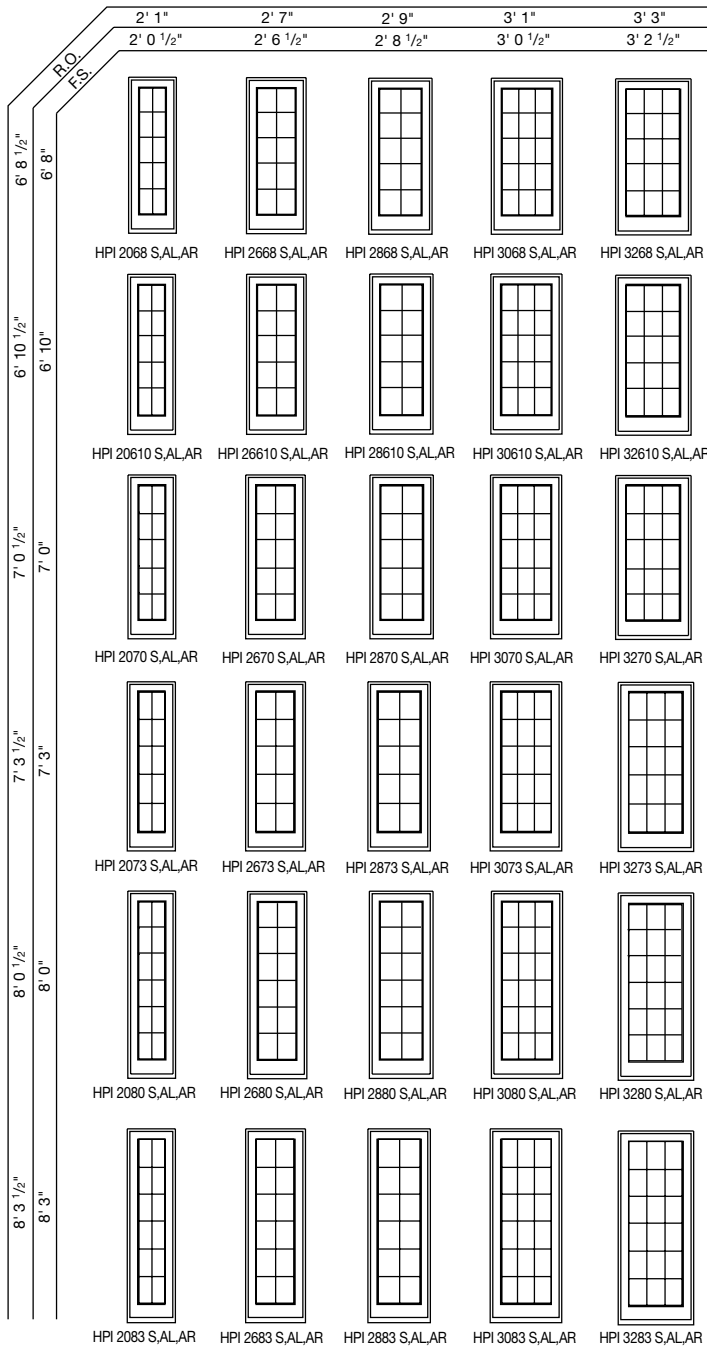

**NOTES**

All doors and sidelights use safety/tempered glass.

The minimum vertical joining material width for doors and sidelights is 1/2".

See handing chart on page 132 for operation options.

Use structural joining material when necessary or required by code.

The light patterns illustrated apply to removable interior wood grilles, Full Divided Light, Simulated Divided Light, Decorelle 100, 150 and 400 and Finelight™ Grille-Between-the-Glass. All removable interior wood grilles will be installed in the units unless otherwise specified.

For a metric conversion in millimeters, multiply dimensions in inches by 25.4.

**Inswing Frame Height  
(using Low Threshold Sill)**  
= Standard Inswing Frame Height – 15/16"

**FORMULA FOR COMBINATION DOORS**

The overall frame dimension (both width and height) is equal to the sum of the individual unit frame dimensions plus joining material dimension(s).

The overall rough opening (both width and height) is equal to the overall frame dimensions plus 1/4" on all sides.

Any unit within each combination can be operating or stationary except for direct-set units and transoms.

## Double Hinged Inswing Patio Door Sizes

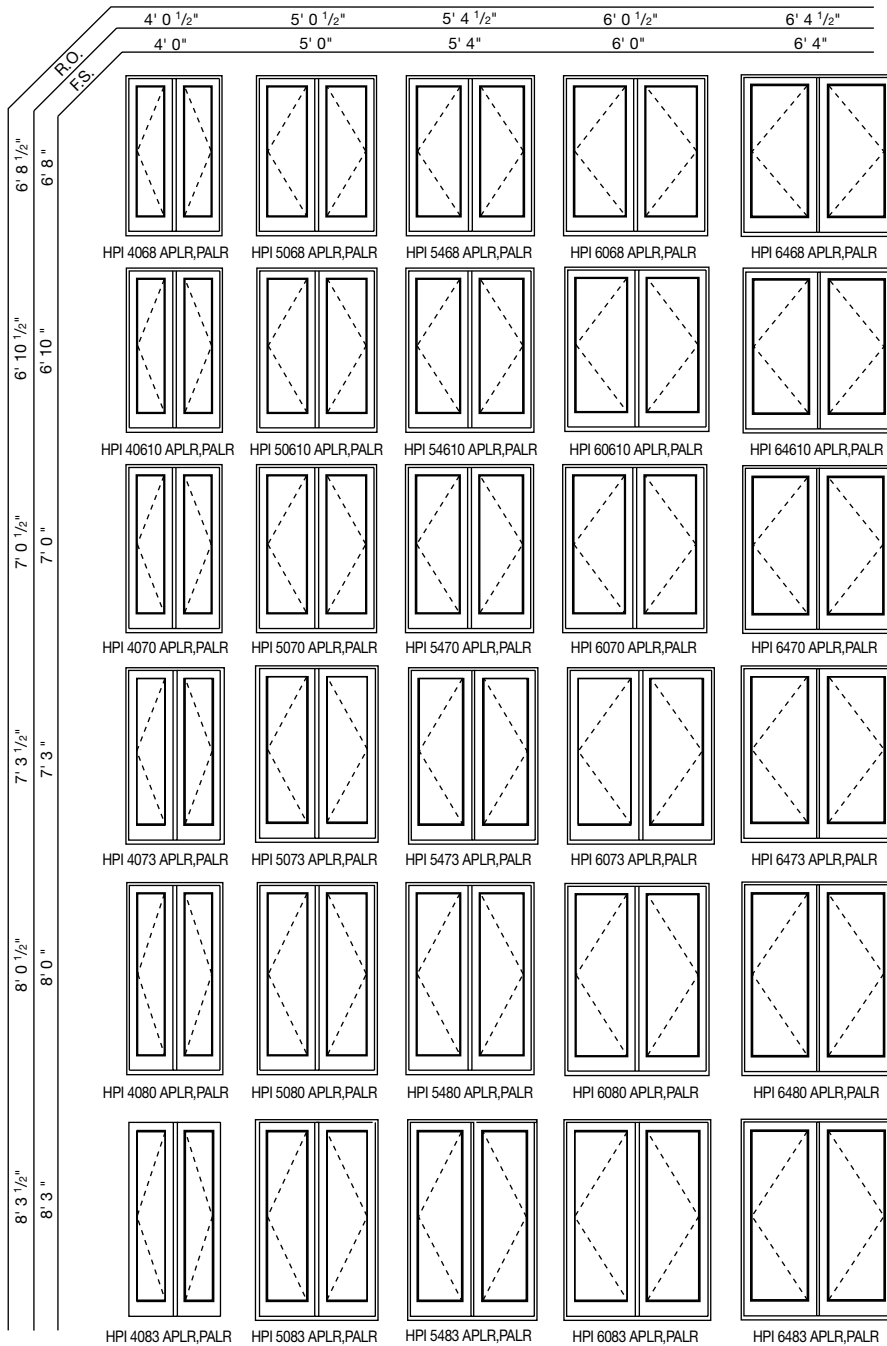

### NOTES

All doors and sidelights use safety/tempered glass.

The minimum vertical joining material width for doors and sidelights is 1/2".

See handing chart on page 132 for operation options.

Use structural joining material when necessary or required by code.

For a metric conversion in millimeters, multiply dimensions in inches by 25.4.

### Inswing Frame Height (using Low Threshold Sill)

= Standard Inswing Frame Height - 15/16"

### FORMULA FOR COMBINATION DOORS

The overall frame dimension (both width and height) is equal to the sum of the individual unit frame dimensions plus joining material dimension(s).

The overall rough opening (both width and height) is equal to the overall frame dimensions plus 1/4" on all sides.

Any unit within each combination can be operating or stationary except for direct-set units and transoms.

### ALSO AVAILABLE AS:

Stationary Doors SS  
Center Post Doors SAR, ASL, SAL, ASR

## Inswing Sash-Set Sidelight Sizes

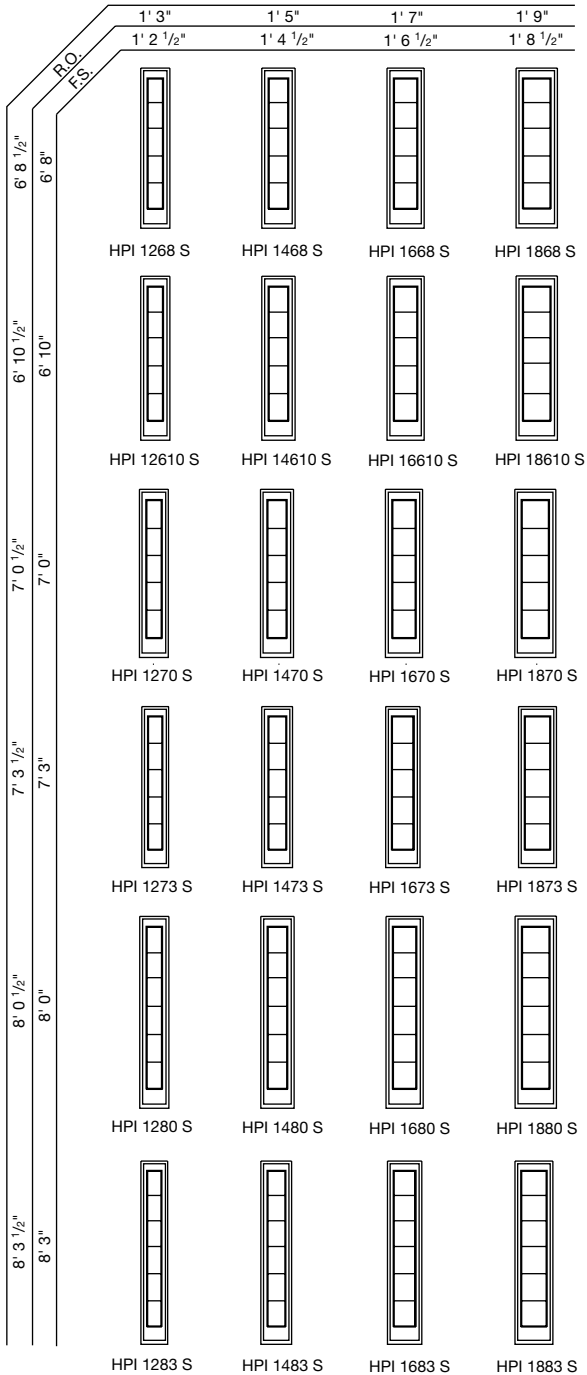

## Inswing Direct-Set Sidelight Sizes

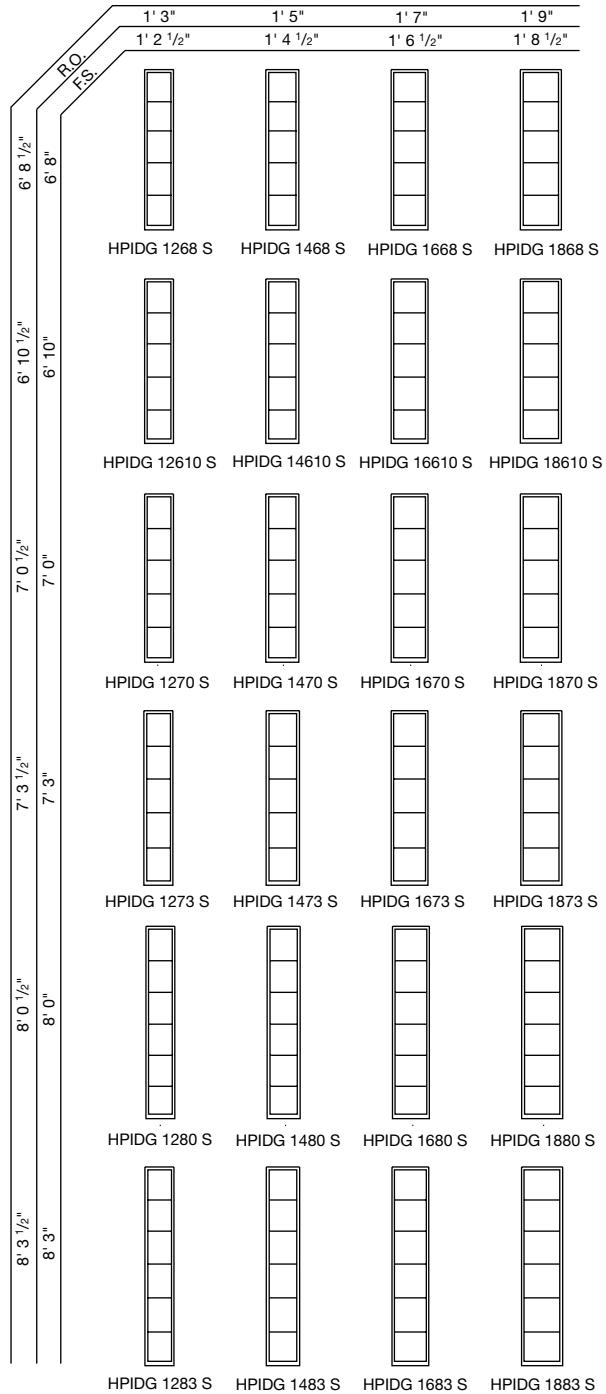

### NOTES

All doors and sidelights use safety/tempered glass.

The minimum vertical joining material width for doors and sidelights is 1/2". When joining a venting sidelight to a door, the minimum vertical joining material width is 2".

Use structural joining material when necessary or required by code.

The light patterns illustrated apply to removable interior wood grilles, Full Divided Light, Simulated Divided Light, Decorelle 100, 150 and 400 and Finelight™ Grilles-Between-the-Glass. All removable interior wood grilles will be installed in the units unless otherwise specified.

For a metric conversion in millimeters, multiply dimensions in inches by 25.4.

### Inswing Frame Height (using Low Threshold Sill)

= Standard Inswing Frame Height - 15/16"

### FORMULA FOR COMBINATION DOORS

The overall frame dimension (both width and height) is equal to the sum of the individual unit frame dimensions plus joining material dimension(s).

The overall rough opening (both width and height) is equal to the overall frame dimensions plus 1/4" on all sides.

Any unit within each combination can be operating or stationary except for direct-set units and transoms.

### Hinged Inswing Patio Door Sash-Set Transom Sizes

	2' 1"	2' 7"	2' 9"	3' 1"	3' 3"	4' 0 <sup>1</sup> / <sub>2</sub> "	5' 0 <sup>1</sup> / <sub>2</sub> "	5' 4 <sup>1</sup> / <sub>2</sub> "	6' 0 <sup>1</sup> / <sub>2</sub> "	6' 4 <sup>1</sup> / <sub>2</sub> "
	2' 0 <sup>1</sup> / <sub>2</sub> "	2' 6 <sup>1</sup> / <sub>2</sub> "	2' 8 <sup>1</sup> / <sub>2</sub> "	3' 0 <sup>1</sup> / <sub>2</sub> "	3' 2 <sup>1</sup> / <sub>2</sub> "	4' 0"	5' 0"	5' 4"	6' 0"	6' 4"
1' 2"										
1' 4"										
1' 6"										
1' 8"										
2' 0"										
2' 4"										
2' 6"										
2' 8"										
3' 0"										

### Hinged Inswing Patio Door Sash-Set Transom Sizes

	1' 3"	1' 5"	1' 7"	1' 9"
	1' 2 <sup>1</sup> / <sub>2</sub> "	1' 4 <sup>1</sup> / <sub>2</sub> "	1' 6 <sup>1</sup> / <sub>2</sub> "	1' 8 <sup>1</sup> / <sub>2</sub> "
1' 2"				
1' 4"				
1' 6"				
1' 8"				
2' 0"				
2' 4"				
2' 6"				
2' 8"				
3' 0"				

**NOTES**

If glass is positioned within 18" of the finished floor, safety/tempered glass may be required. Local codes may differ. Verify tempered glass requirements with your local building code official.

Use structural joining material when necessary or required by code.

The light patterns illustrated apply to removable interior wood grilles, Full Divided Light, Simulated Divided Light, Decorelle 100, 150 and 400 and Finelight™ Grilles-Between-the-Glass. All removable interior wood grilles will be installed in the units unless otherwise specified. The staggered light patterns illustrated align with light patterns in double doors. Other light patterns are available upon request.

For a metric conversion in millimeters, multiply dimensions in inches by 25.4.

**FORMULA FOR COMBINATION DOORS**

The overall frame dimension (both width and height) is equal to the sum of the individual unit frame dimensions plus joining material dimension(s).

The overall rough opening (both width and height) is equal to the overall frame dimensions plus 1/4" on all sides.

Any unit within each combination can be operating or stationary except for direct-set units and transoms.

## Hinged Inswing Patio Door Direct-Set Transom Sizes (Specialty Frame)

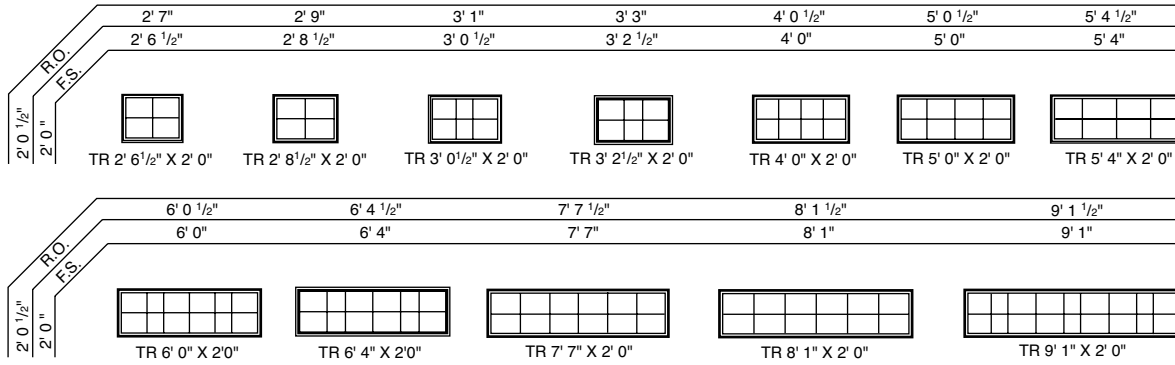

## Hinged Inswing Patio Door Direct-Set Elliptical Sizes (Specialty Frame)

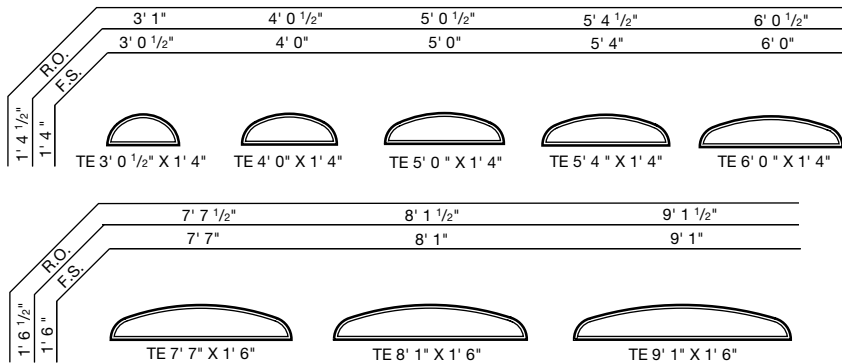

### NOTES

If glass is positioned within 18" of the finished floor, safety/tempered glass may be required. Local codes may differ. Verify tempered glass requirements with your local building code official.

- 2' 6-1/2" wide transoms are used above 2668, 26610 or 2680 Hinged Inswing Patio Doors.
- 2' 8-1/2" wide transoms are used above 2868, 28610 or 2880 Hinged Inswing Patio Doors.
- 3' 0-1/2" wide transoms are used above 3068, 30610 or 3080 Hinged Inswing Patio Doors.
- 4' 0" wide transoms are used above 4068, 40610 or 4080 Hinged Inswing Patio Doors.
- 5' 0" wide transoms are used above 5068, 50610 or 5080 Hinged Inswing Patio Doors.
- 5' 4" wide transoms are used above 5468, 54610 or 5480 Hinged Inswing Patio Doors.
- 6' 0" wide transoms are used above 6068, 60610 or 6080 Hinged Inswing Patio Doors.
- 7' 7" wide transoms are used above 5068/50610/5080 Hinged Inswing Patio Doors with 2668/26610/2680 Sidelights.
- 8' 1" wide transoms are used above 5468/54610/5480 Hinged Inswing Patio Doors with 2868/28610/2880 Sidelights.
- 9' 1" wide transoms are used above 6068/60610/6080 Hinged Inswing Patio Doors with 3068/30610/3080 Sidelights.

Use structural joining material when necessary or required by code.

The light patterns illustrated apply to removable interior wood grilles, Full Divided Light, Simulated Divided Light, Decorelle 100, 150 and 400 and Finelight™ Grilles-Between-the-Glass. All removable interior wood grilles will be installed in the units unless otherwise specified. The staggered light patterns illustrated align with light patterns in double doors. Other light patterns are available upon request.

For a metric conversion in millimeters, multiply dimensions in inches by 25.4.

### FORMULA FOR COMBINATION DOORS

The overall frame dimension (both width and height) is equal to the sum of the individual unit frame dimensions plus joining material dimension(s).

The overall rough opening (both width and height) is equal to the overall frame dimensions plus 1/4" on all sides.

Any unit within each combination can be operating or stationary except for direct-set units and transoms.

### Hinged Inswing Patio Door Direct-Set Half Circle Sizes (Specialty Frame)

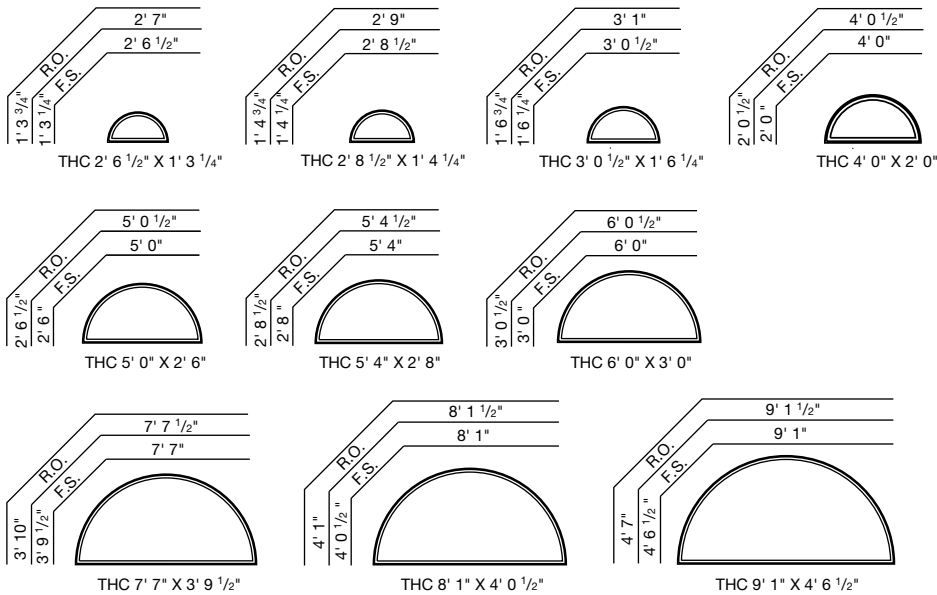

### Hinged Inswing Patio Door Direct-Set Transom Sizes

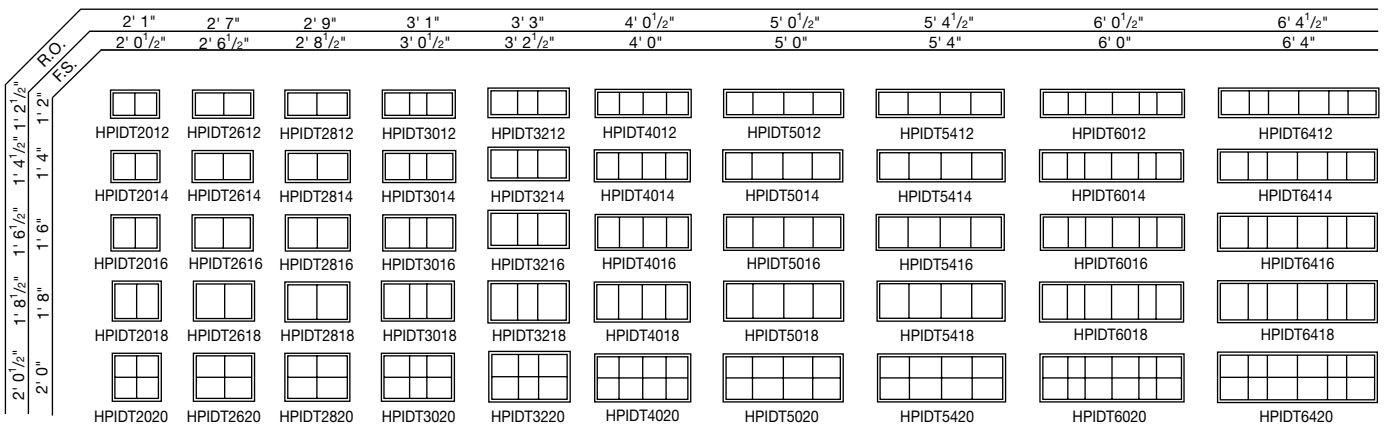

**NOTES**

If glass is positioned within 18" of the finished floor, safety/tempered glass may be required. Local codes may differ. Verify tempered glass requirements with your local building code official.

- 2' 6-1/2" wide transoms are used above 2668, 26610 or 2680 Hinged Inswing Patio Doors.
- 2' 8-1/2" wide transoms are used above 2868, 28610 or 2880 Hinged Inswing Patio Doors.
- 3' 0-1/2" wide transoms are used above 3068, 30610 or 3080 Hinged Inswing Patio Doors.
- 4' 0" wide transoms are used above 4068, 40610 or 4080 Hinged Inswing Patio Doors.
- 5' 0" wide transoms are used above 5068, 50610 or 5080 Hinged Inswing Patio Doors.
- 5' 4" wide transoms are used above 5468, 54610 or 5480 Hinged Inswing Patio Doors.
- 6' 0" wide transoms are used above 6068, 60610 or 6080 Hinged Inswing Patio Doors.
- 7' 7" wide transoms are used above 5068/50610/5080 Hinged Inswing Patio Doors with 2668/26610/2680 Sidelights.
- 8' 1" wide transoms are used above 5468/54610/5480 Hinged Inswing Patio Doors with 2868/28610/2880 Sidelights.
- 9' 1" wide transoms are used above 6068/60610/6080 Hinged Inswing Patio Doors with 3068/30610/3080 Sidelights.

Use structural joining material when necessary or required by code.

The light patterns illustrated apply to removable interior wood grilles, Full Divided Light, Simulated Divided Light, Decorelle 100, 150 and 400 and Finelight™ Grilles-Between-the-Glass. All removable interior wood grilles will be installed in the units unless otherwise specified. The staggered light patterns illustrated align with light patterns in double doors. Other light patterns are available upon request.

For a metric conversion in millimeters, multiply dimensions in inches by 25.4.

**FORMULA FOR COMBINATION DOORS**

The overall frame dimension (both width and height) is equal to the sum of the individual unit frame dimensions plus joining material dimension(s).

The overall rough opening (both width and height) is equal to the overall frame dimensions plus 1/4" on all sides.

Any unit within each combination can be operating or stationary except for direct-set units and transoms.

**FOR WINDOWS OVER 30 SQUARE FEET OR RATED HIGHER THAN PG50, ONE OF THESE THREE INSTALLATION METHODS IS REQUIRED:  
A) THROUGH THE JAMB B) ALUMINUM NAILING FLANGE OR C) INSTALLATION CLIPS.  
ADDITIONAL CUSTOM SIZES ARE AVAILABLE. CONTACT YOUR LOCAL SUPPLIER FOR MORE INFORMATION. DRAWINGS ARE NOT TO SCALE.**

## Hinged Inswing Patio Door Direct-Set Transom Sizes

		2' 1"	2' 7"	2' 9"	3' 1"	3' 3"	4' 0 <sup>1</sup> / <sub>2</sub> "	5' 0 <sup>1</sup> / <sub>2</sub> "	5' 4 <sup>1</sup> / <sub>2</sub> "	6' 0 <sup>1</sup> / <sub>2</sub> "	6' 4 <sup>1</sup> / <sub>2</sub> "
		2' 0 <sup>1</sup> / <sub>2</sub> "	2' 6 <sup>1</sup> / <sub>2</sub> "	2' 8 <sup>1</sup> / <sub>2</sub> "	3' 0 <sup>1</sup> / <sub>2</sub> "	3' 2 <sup>1</sup> / <sub>2</sub> "	4' 0"	5' 0"	5' 4"	6' 0"	6' 4"
RO FS	2' 4 <sup>1</sup> / <sub>2</sub> "										
	2' 4"										
	2' 6 <sup>1</sup> / <sub>2</sub> "										
	2' 6"										
2' 8 <sup>1</sup> / <sub>2</sub> "											
2' 8"											
3' 0 <sup>1</sup> / <sub>2</sub> "											
3' 0"											

## Hinged Inswing Patio Door Direct-Set Transom Sizes

		1' 3"	1' 5"	1' 7"	1' 9"
		1' 2 <sup>1</sup> / <sub>2</sub> "	1' 4 <sup>1</sup> / <sub>2</sub> "	1' 6 <sup>1</sup> / <sub>2</sub> "	1' 8 <sup>1</sup> / <sub>2</sub> "
RO FS	1' 2"				
	1' 4"				
	1' 4 <sup>1</sup> / <sub>2</sub> "				
	1' 6"				
	1' 6 <sup>1</sup> / <sub>2</sub> "				
	1' 8"				
	1' 8 <sup>1</sup> / <sub>2</sub> "				
	2' 0"				
	2' 0 <sup>1</sup> / <sub>2</sub> "				
	2' 2"				
	2' 2 <sup>1</sup> / <sub>2</sub> "				
	2' 4"				
	2' 4 <sup>1</sup> / <sub>2</sub> "				
	2' 6"				
	2' 6 <sup>1</sup> / <sub>2</sub> "				
	2' 8"				
3' 0 <sup>1</sup> / <sub>2</sub> "					

### NOTES

If glass is positioned within 18" of the finished floor, safety/tempered glass may be required. Local codes may differ. Verify tempered glass requirements with your local building code official.

Use structural joining material when necessary or required by code.

The light patterns illustrated apply to removable interior wood grilles, Full Divided Light, Simulated Divided Light, Decorelle 100, 150 and 400 and Finelight™ Grilles-Between-the-Glass. All removable interior wood grilles will be installed in the units unless otherwise specified. The staggered light patterns illustrated align with light patterns in double doors. Other light patterns are available upon request.

For a metric conversion in millimeters, multiply dimensions in inches by 25.4.

### FORMULA FOR COMBINATION DOORS

The overall frame dimension (both width and height) is equal to the sum of the individual unit frame dimensions plus joining material dimension(s).

The overall rough opening (both width and height) is equal to the overall frame dimensions plus 1/4" on all sides.

Any unit within each combination can be operating or stationary except for direct-set units and transoms.



## Single Arch Inswing Patio Door & Sidelight Sizes

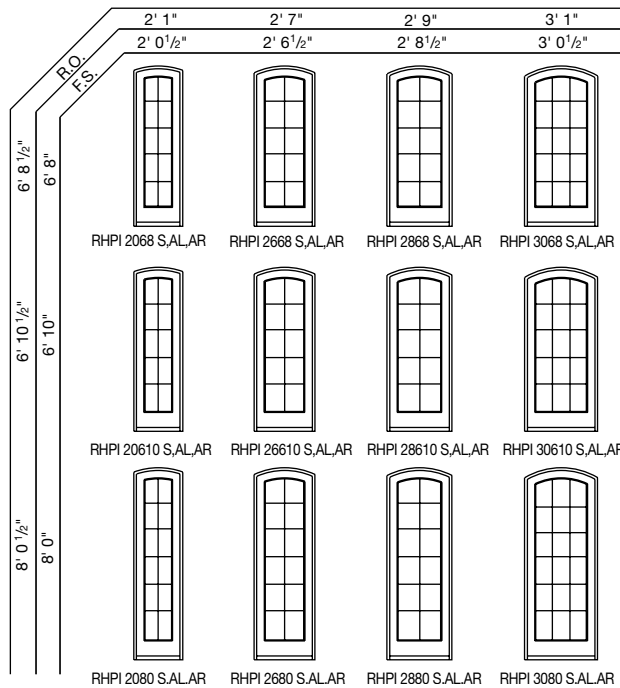

### NOTES

All doors and sidelights use safety/tempered glass.

Single doors have a 3' 0" radius.

Double doors have a 5' 0" radius.

See handing chart on page 132 for operation options.

Use structural joining material when necessary or required by code.

The light patterns illustrated apply to removable interior wood grilles, Full Divided Light, Simulated Divided Light, Decorelle 100, 150 and 400 and Finelight™ Grilles-Between-the-Glass. All removable wood grilles will be installed in the units unless otherwise specified.

For a metric conversion in millimeters, multiply dimensions in inches by 25.4.

### Inswing Frame Height (using Low Threshold Sill)

= Standard Inswing Frame Height - 15/16"

### FORMULA FOR COMBINATION DOORS

The overall frame dimension (both width and height) is equal to the sum of the individual unit frame dimensions plus joining material dimension(s).

The overall rough opening (both width and height) is equal to the overall frame dimensions plus 1/4" on all sides.

Any unit within each combination can be operating or stationary except for direct-set units and transoms.

## Double Arch Inswing Patio Door Sizes

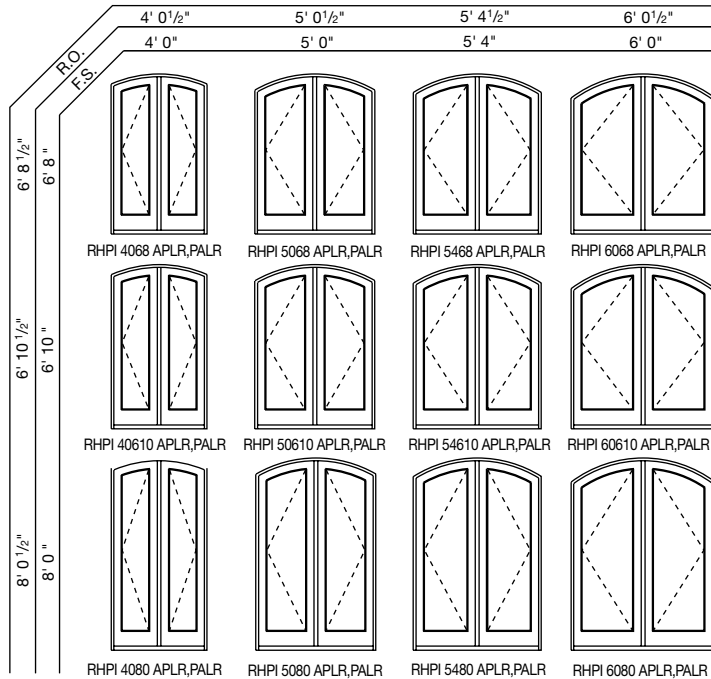

### 3-Wide Arch Inswing Patio Door & Sidelight Sizes

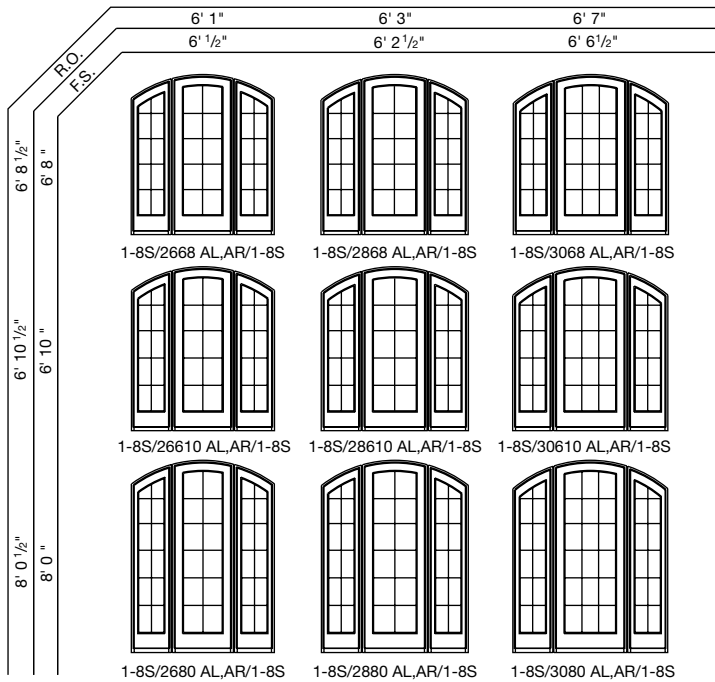

**NOTES**

All doors and sidelights use safety/tempered glass.

3-wide doors have a 5' 0" radius.

See handing chart on page 132 for operation options.

Use structural joining material when necessary or required by code.

The light patterns illustrated apply to removable interior wood grilles, Full Divided Light, Simulated Divided Light, Decorelle 100, 150 and 400 and Finelight™ Grilles-Between-the-Glass. All removable interior wood grilles will be installed in the units unless otherwise specified.

For a metric conversion in millimeters, multiply dimensions in inches by 25.4.

**Inswing Frame Height Formula  
(using Low Threshold Sill)**  
= Standard Inswing Frame Height – 15/16"

**FORMULA FOR COMBINATION DOORS**

The overall frame dimension (both width and height) is equal to the sum of the individual unit frame dimensions plus joining material dimension(s).

The overall rough opening (both width and height) is equal to the overall frame dimensions plus 1/4" on all sides.

Any unit within each combination can be operating or stationary except for arch sidelights.

## Hinged Inswing Patio Doors (4 9/16" Jamb Depth)

### Hinged Inswing Patio Door

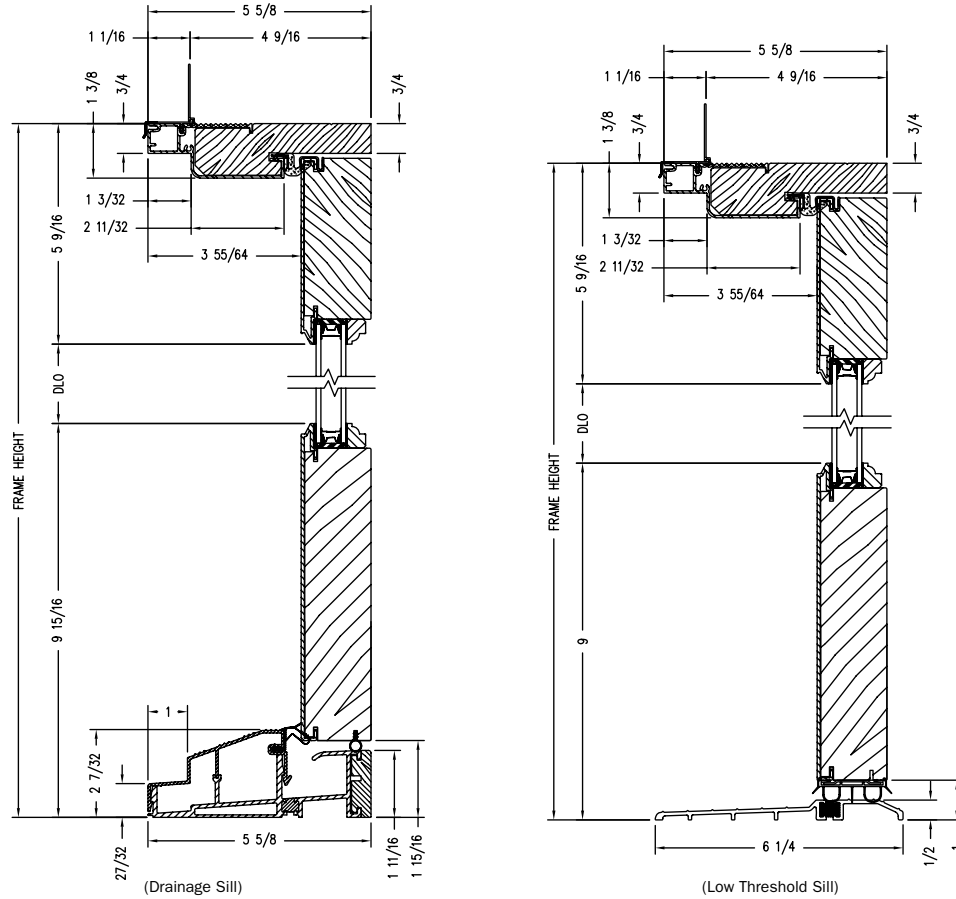

Vertical Section

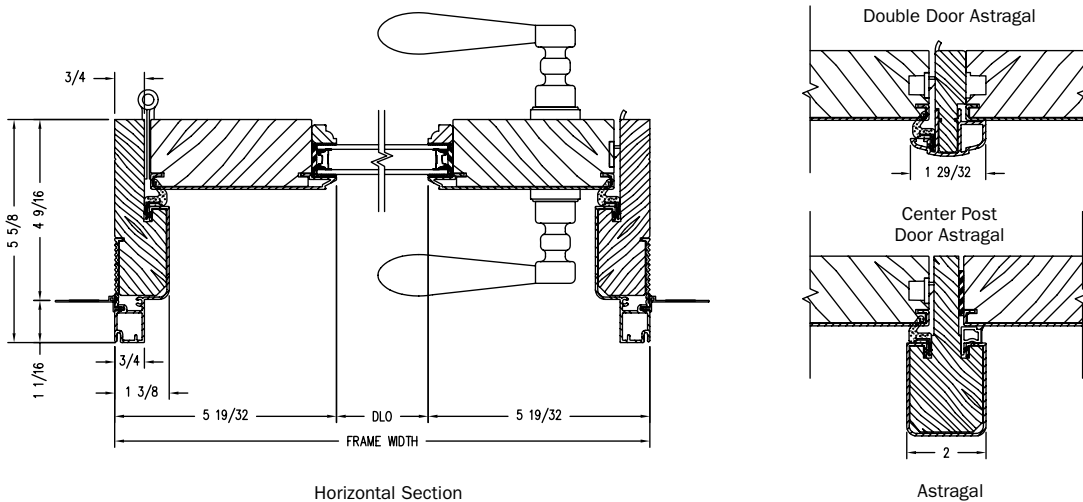

Shown with ovolo (colonial) glass stops.  
French panel shown, also available with a contemporary panel.

# Inswing Hinged Patio Doors (4 9/16" Jamb Depth)

## Inswing Sash-Set Sidelight

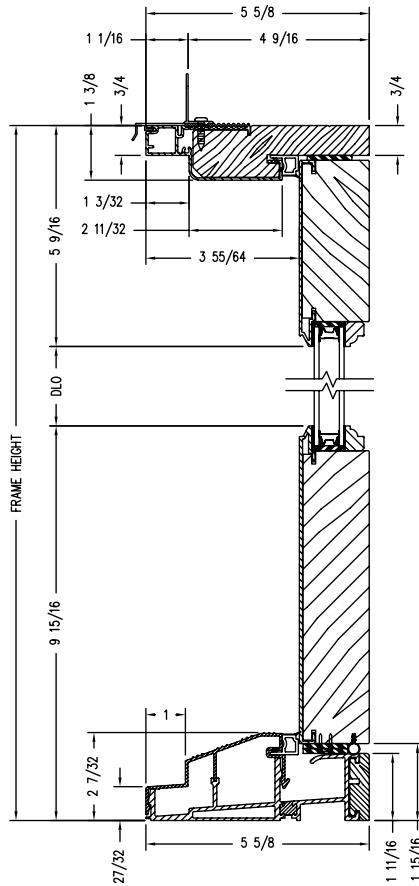

(Drainage Sill)

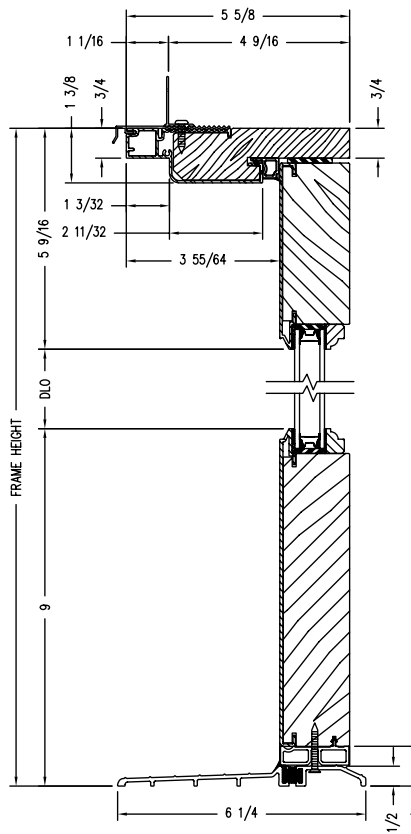

(Low Threshold Sill)

Vertical Section

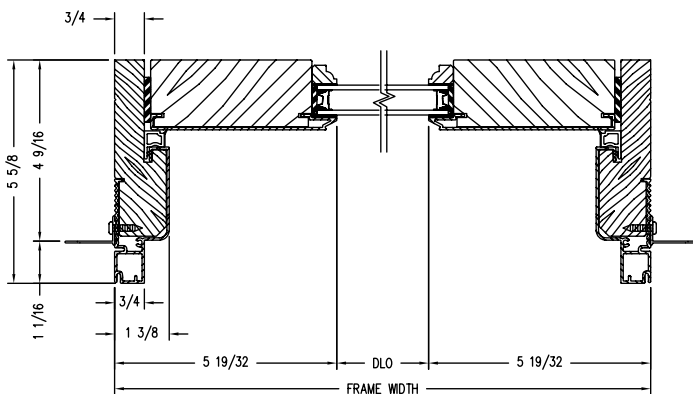

Horizontal Section

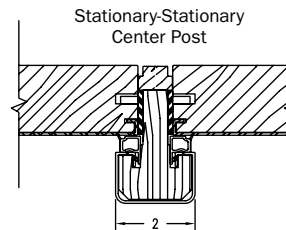

Astragal

Shown with ovolo (colonial) glass stops.



## Hinged Inswing Patio Doors (4 9/16" Jamb Depth)

**Inswing Direct-Set Sidelight**

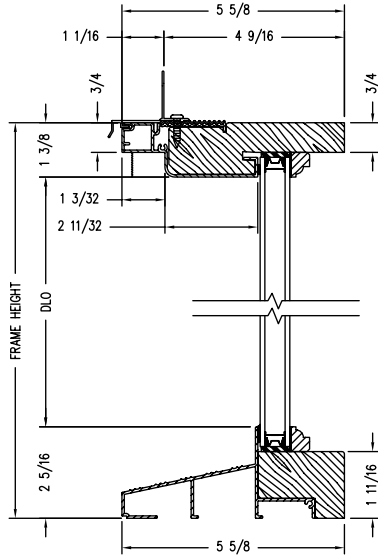

Vertical Section

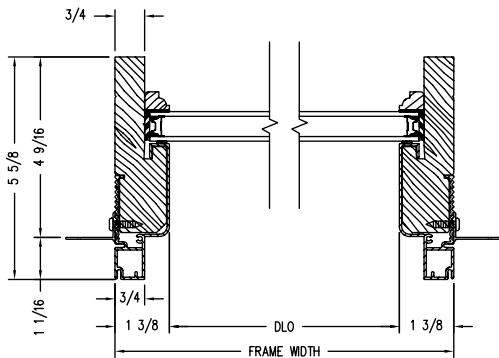

Horizontal Section

**Inswing Venting Sidelight**

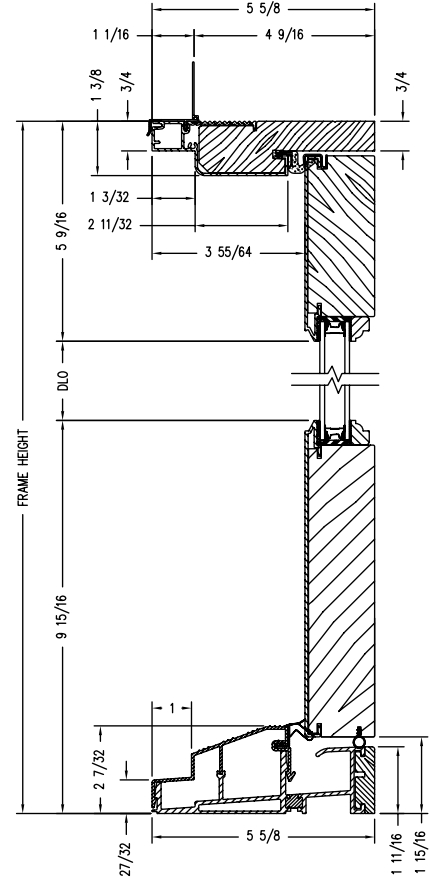

Vertical Section

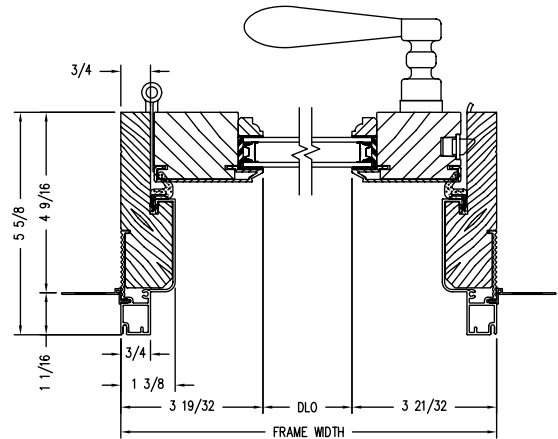

Horizontal Section

Shown with ovolo (colonial) glass stops.

## Hinged Inswing Patio Doors (4 9/16" Jamb Depth)

**Inswing Sash-Set Transom**

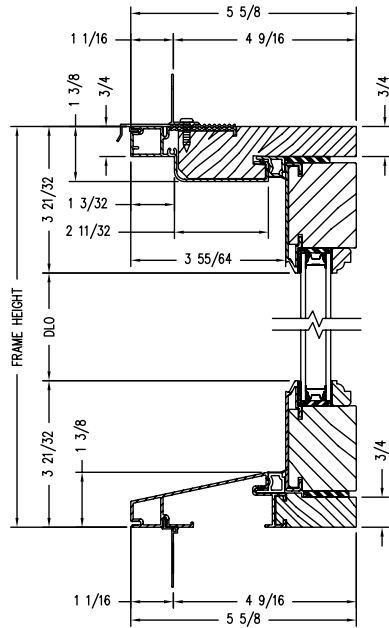

Vertical Section

**Inswing Direct-Set Transom**

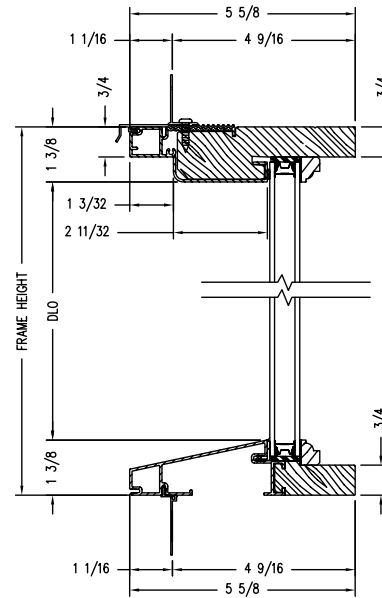

Vertical Section

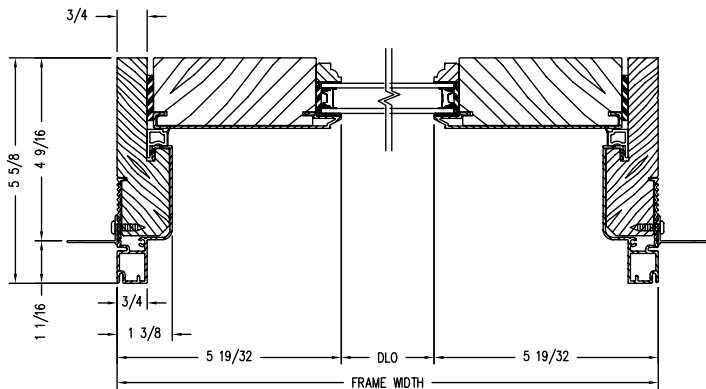

Horizontal Section

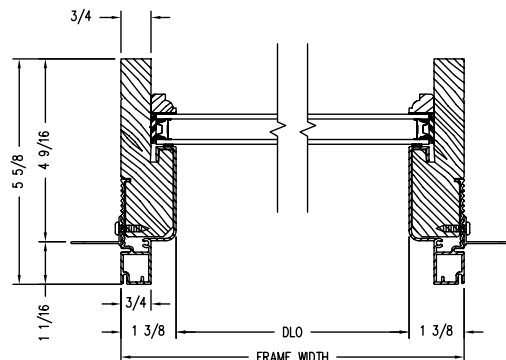

Horizontal Section

Shown with ovolo (colonial) glass stops.



## Hinged Inswing Patio Doors (6 9/16" Jamb Depth)

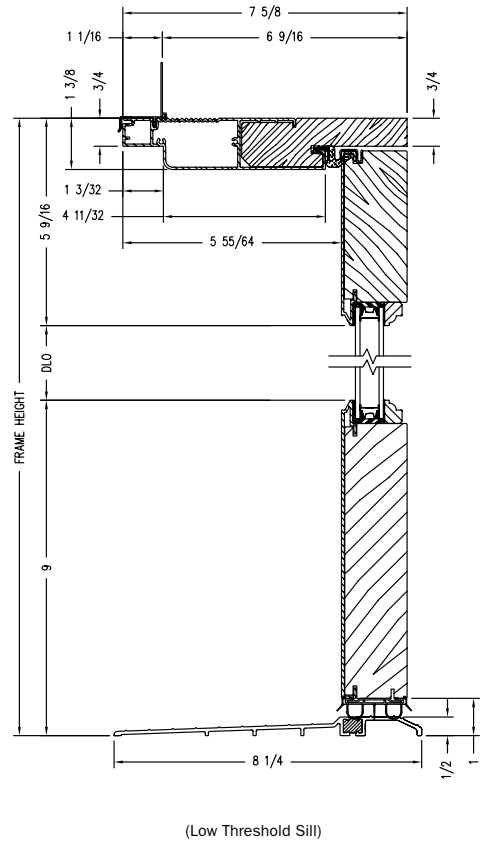
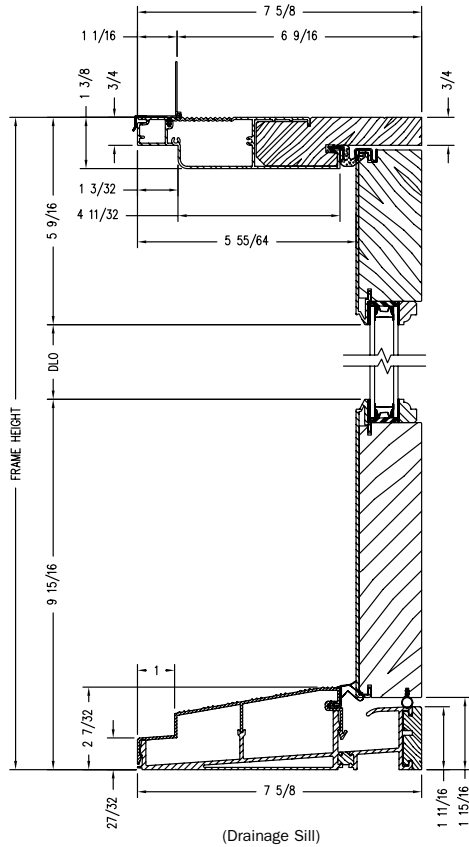

Vertical Section

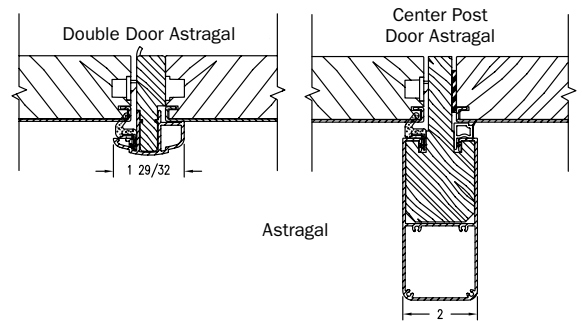
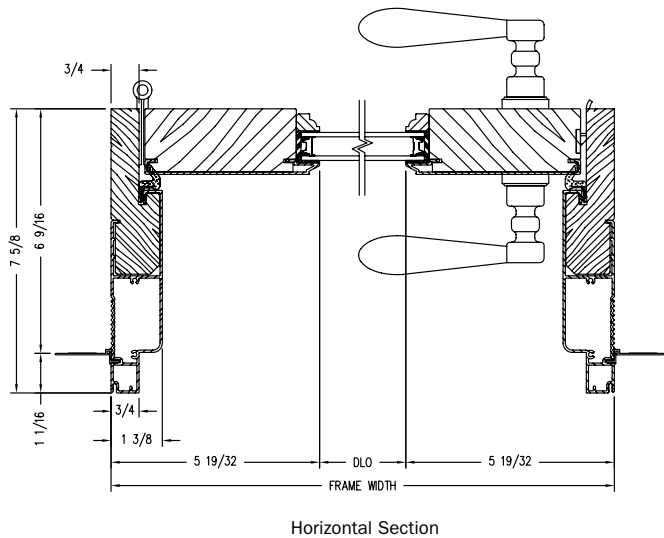

Shown with ovolo (colonial) glass stops.

French panel shown, also available with a contemporary panel.

Visit our website to see transoms and sidelight units with 6-9/16" jamb depth.

---

## Hinged Inswing Patio Door Handing (As Viewed From Exterior)

---

INSWING SINGLE DOOR



INSWING DOUBLE DOOR



INSWING CENTER POST DOOR

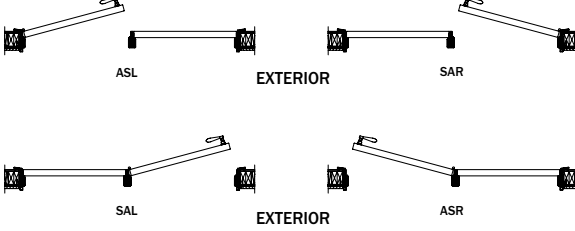

---

## Hinged Outswing Patio Door Handing (As Viewed From Exterior)

---

OUTSWING SINGLE DOOR

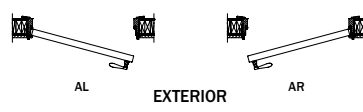

OUTSWING DOUBLE DOOR

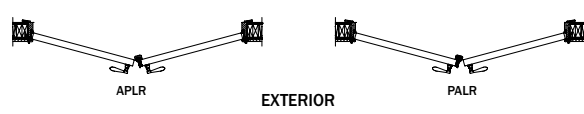



## Double Hinged Outswing Patio Door Sizes

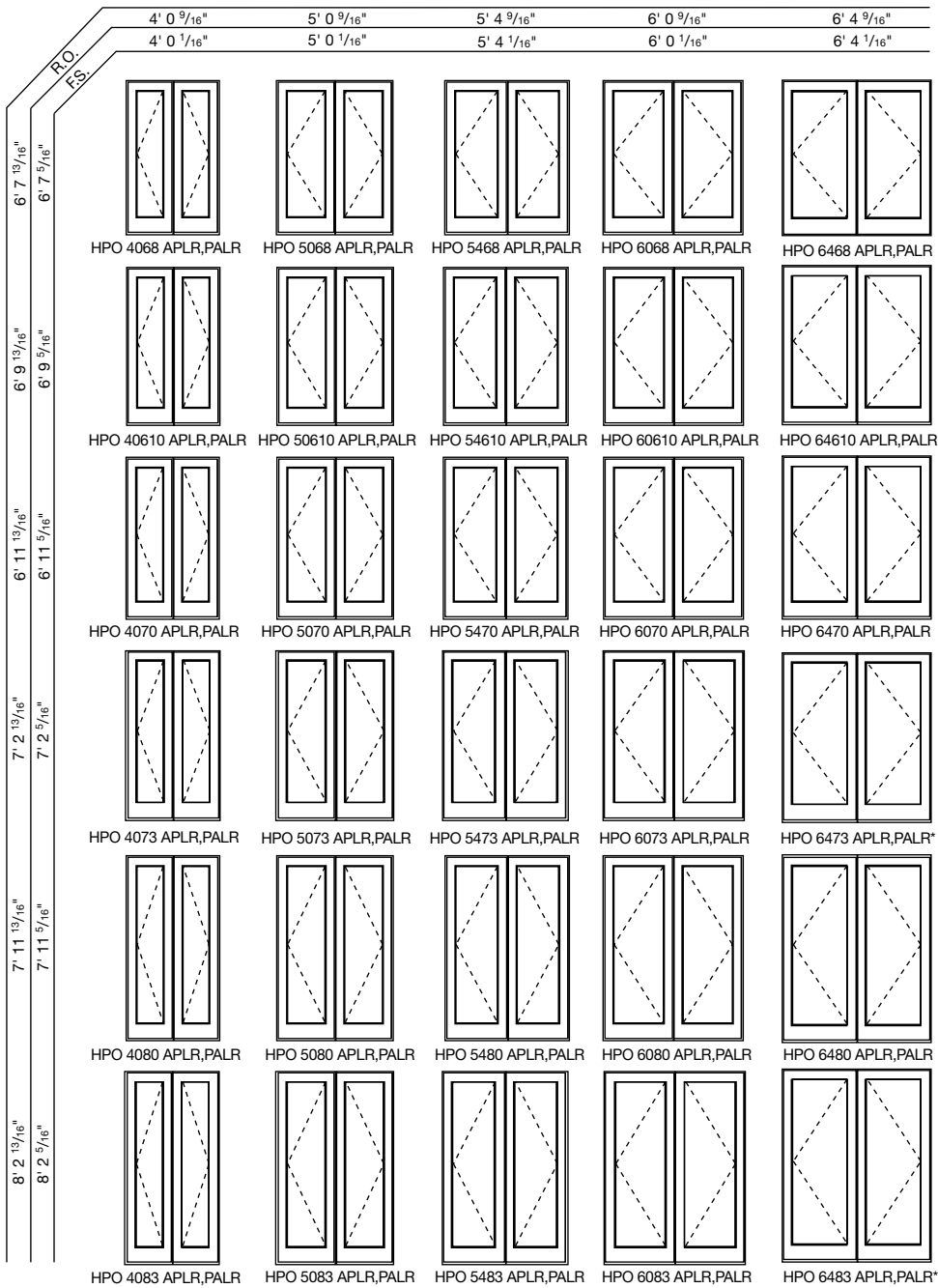

**NOTES**

All doors and sidelights use safety/tempered glass.

The minimum vertical joining material width for doors and sidelights is 1/2".

\*Commercial sized door panels.

See handing chart on page 132 for operation options.

Use structural joining material when necessary or required by code.

For a metric conversion in millimeters, multiply dimensions in inches by 25.4.

**FORMULA FOR COMBINATION DOORS**

The overall frame dimension (both width and height) is equal to the sum of the individual unit frame dimensions plus joining material dimension(s).

The overall rough opening (both width and height) is equal to the overall frame dimensions plus 1/4" on all sides.

Any unit within each combination can be operating or stationary except for direct-set units and transoms.

**Outswing Frame Height Formula**  
(using Low Threshold Sill)  
= Standard Outswing Frame Height – 7/16"

## Outswing Sash-Set Sidelight Sizes

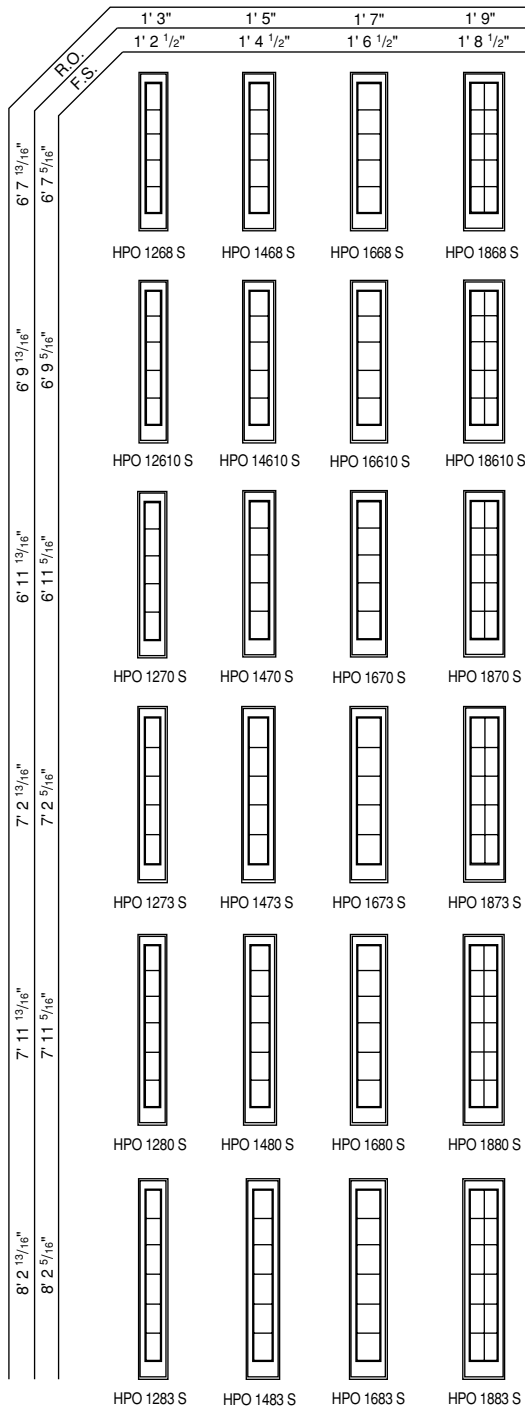

### NOTES

All doors and sidelights use safety/tempered glass.

The minimum vertical joining material width for doors and sidelights is 1/2". When joining a venting sidelight to a door, the minimum vertical joining material width is 2".

\*Commercial sized door panels.

See handing chart on page 132 for operation options.

Use structural joining material when necessary or required by code.

The light patterns illustrated apply to removable interior wood grilles, Full Divided Light, Simulated Divided Light, Decorelle 100, 150 and 400 and Finelight™ Grilles-Between-the-Glass. All removable interior wood grilles will be installed in the units unless otherwise specified.

134

**FOR WINDOWS OVER 30 SQUARE FEET OR RATED HIGHER THAN PG50, ONE OF THESE THREE INSTALLATION METHODS IS REQUIRED:  
A) THROUGH THE JAMB B) ALUMINUM NAILING FLANGE OR C) INSTALLATION CLIPS.  
ADDITIONAL CUSTOM SIZES ARE AVAILABLE. CONTACT YOUR LOCAL SUPPLIER FOR MORE INFORMATION. DRAWINGS ARE NOT TO SCALE.**

## Single Hinged Outswing Patio Door & Sidelight Sizes

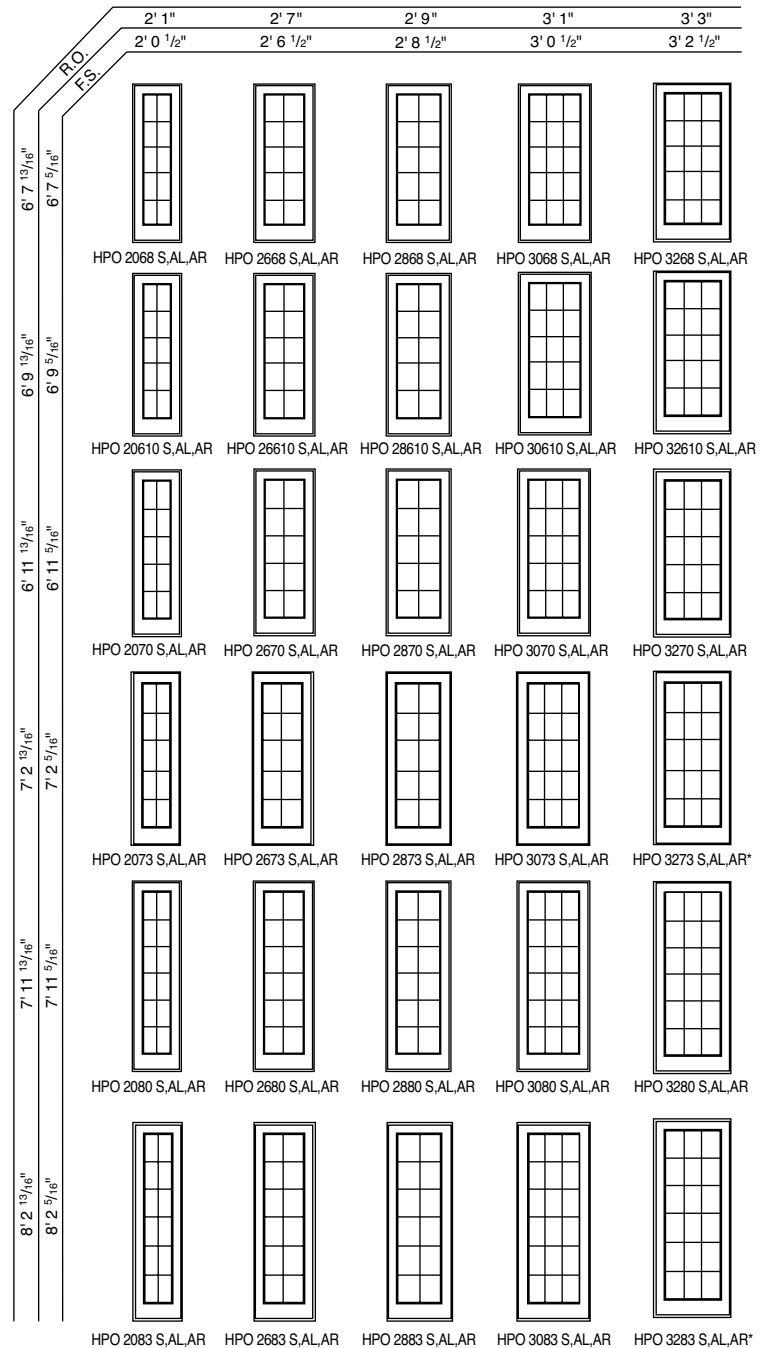

For a metric conversion in millimeters, multiply dimensions in inches by 25.4.

### Outswing Frame Height Formula (using Low Threshold Sill)

$$= \text{Standard Outswing Frame Height} - 7/16"$$

### FORMULA FOR COMBINATION DOORS

The overall frame dimension (both width and height) is equal to the sum of the individual unit frame dimensions plus joining material dimension(s).

The overall rough opening (both width and height) is equal to the overall frame dimensions plus 1/4" on all sides.

Any unit within each combination can be operating or stationary except for direct-set units and transoms.

### Hinged Outswing Patio Door Sash-Set Transom Sizes

	2' 1"	2' 7"	2' 9"	3' 1"	3' 3"	4' 0 <sup>9</sup> / <sub>16</sub> "	5' 0 <sup>9</sup> / <sub>16</sub> "	5' 4 <sup>9</sup> / <sub>16</sub> "	6' 0 <sup>9</sup> / <sub>16</sub> "	6' 4 <sup>9</sup> / <sub>16</sub> "
	2' 0 <sup>1</sup> / <sub>2</sub> "	2' 6 <sup>1</sup> / <sub>2</sub> "	2' 8 <sup>1</sup> / <sub>2</sub> "	3' 0 <sup>1</sup> / <sub>2</sub> "	3' 2 <sup>1</sup> / <sub>2</sub> "	4' 0 <sup>1</sup> / <sub>16</sub> "	5' 0 <sup>1</sup> / <sub>16</sub> "	5' 4 <sup>1</sup> / <sub>16</sub> "	6' 0 <sup>1</sup> / <sub>16</sub> "	6' 4 <sup>1</sup> / <sub>16</sub> "
1' 2"	HPOST2012	HPOST2612	HPOST2812	HPOST3012	HPOST3212	HPOST4012	HPOST5012	HPOST5412	HPOST6012	HPOST6412
1' 4"	HPOST2014	HPOST2614	HPOST2814	HPOST3014	HPOST3214	HPOST4014	HPOST5014	HPOST5414	HPOST6014	HPOST6414
1' 6"	HPOST2016	HPOST2616	HPOST2816	HPOST3016	HPOST3216	HPOST4016	HPOST5016	HPOST5416	HPOST6016	HPOST6416
1' 8"	HPOST2018	HPOST2618	HPOST2818	HPOST3018	HPOST3218	HPOST4018	HPOST5018	HPOST5418	HPOST6018	HPOST6418
2' 0"	HPOST2020	HPOST2620	HPOST2820	HPOST3020	HPOST3220	HPOST4020	HPOST5020	HPOST5420	HPOST6020	HPOST6420
2' 4"	HPOST2024	HPOST2624	HPOST2824	HPOST3024	HPOST3224	HPOST4024	HPOST5024	HPOST5424	HPOST6024	HPOST6424
2' 6"	HPOST2026	HPOST2626	HPOST2826	HPOST3026	HPOST3226	HPOST4026	HPOST5026	HPOST5426	HPOST6026	HPOST6426
2' 8"	HPOST2028	HPOST2628	HPOST2828	HPOST3028	HPOST3228	HPOST4028	HPOST5028	HPOST5428	HPOST6028	HPOST6428
3' 0"	HPOST2030	HPOST2630	HPOST2830	HPOST3030	HPOST3230	HPOST4030	HPOST5030	HPOST5430	HPOST6030	HPOST6430

### Hinged Outswing Patio Door Sash-Set Transom Sizes

	1' 3"	1' 5"	1' 7"	1' 9"
	1' 2 <sup>1</sup> / <sub>2</sub> "	1' 4 <sup>1</sup> / <sub>2</sub> "	1' 6 <sup>1</sup> / <sub>2</sub> "	1' 8 <sup>1</sup> / <sub>2</sub> "
1' 2"	HPOST1212	HPOST1412	HPOST1612	HPOST1812
1' 4"	HPOST1214	HPOST1414	HPOST1614	HPOST1814
1' 6"	HPOST1216	HPOST1416	HPOST1616	HPOST1816
1' 8"	HPOST1218	HPOST1418	HPOST1618	HPOST1818
2' 0"	HPOST1220	HPOST1420	HPOST1620	HPOST1820

**NOTES**

If glass is positioned within 18" of the finished floor, safety/tempered glass may be required. Local codes may differ. Verify tempered glass requirements with your local building code official.

Use structural joining material when necessary or required by code.

The light patterns illustrated apply to removable interior wood grilles, Full Divided Light, Simulated Divided Light, Decorelle 100, 150 and 400 and Finelight™ Grilles-Between-the-Glass. All removable interior wood grilles will be installed in the units unless otherwise specified. The staggered light patterns illustrated align with light patterns in double doors. Other light patterns are available upon request.

For a metric conversion in millimeters, multiply dimensions in inches by 25.4.

### Hinged Outswing Patio Door Sash-Set Transom Sizes

	1' 3"	1' 5"	1' 7"	1' 9"
	1' 2 <sup>1</sup> / <sub>2</sub> "	1' 4 <sup>1</sup> / <sub>2</sub> "	1' 6 <sup>1</sup> / <sub>2</sub> "	1' 8 <sup>1</sup> / <sub>2</sub> "
2' 4"	HPOST1224	HPOST1424	HPOST1624	HPOST1824
2' 6"	HPOST1226	HPOST1426	HPOST1626	HPOST1826
2' 8"	HPOST1228	HPOST1428	HPOST1628	HPOST1828
3' 0"	HPOST1230	HPOST1430	HPOST1630	HPOST1830

**FORMULA FOR COMBINATION DOORS**

The overall frame dimension (both width and height) is equal to the sum of the individual unit frame dimensions plus joining material dimension(s).

The overall rough opening (both width and height) is equal to the overall frame dimensions plus 1/4" on all sides.

Any unit within each combination can be operating or stationary except for direct-set units and transoms.

## Hinged Outswing Patio Door Direct-Set Transom Sizes (Specialty Frame)

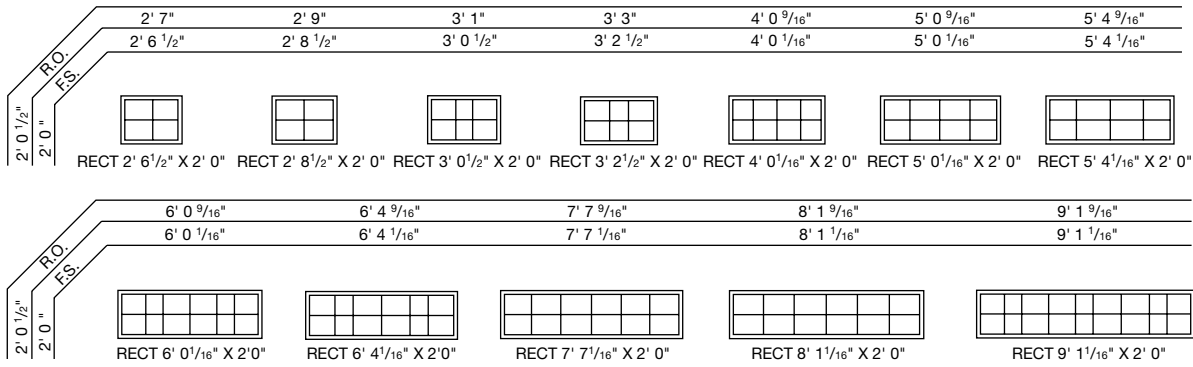

## Hinged Outswing Patio Door Direct-Set Elliptical Sizes (Specialty Frame)

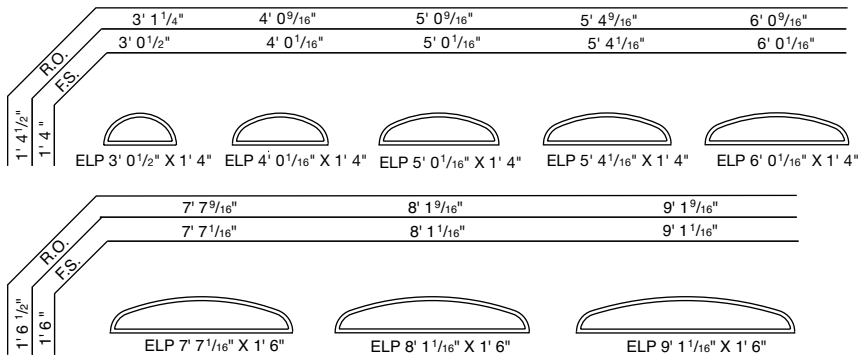

## Hinged Outswing Patio Door Direct-Set Half Circle Sizes (Specialty Frame)

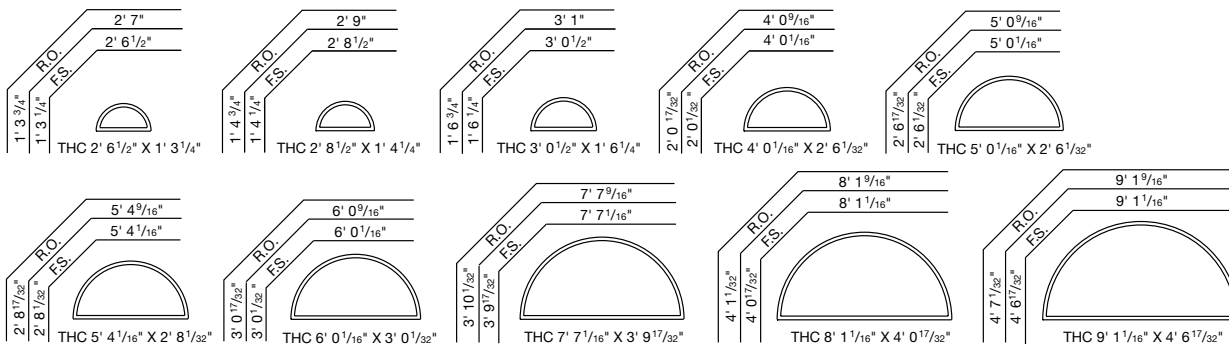

### NOTES

If glass is positioned within 18" of the finished floor, safety/tempered glass may be required. Local codes may differ. Verify tempered glass requirements with your local building code official.

- 2' 6-1/2" wide transoms are used above 2668, 26610 or 2680 Hinged Outswing Patio Doors.
- 2' 8-1/2" wide transoms are used above 2868, 28610 or 2880 Hinged Outswing Patio Doors.
- 3' 0-1/2" wide transoms are used above 3068, 30610 or 3080 Hinged Outswing Patio Doors.
- 4' 0" wide transoms are used above 4068, 40610 or 4080 Hinged Outswing Patio Doors.
- 5' 0" wide transoms are used above 5068, 50610 or 5080 Hinged Outswing Patio Doors.
- 5' 4" wide transoms are used above 5468, 54610 or 5480 Hinged Outswing Patio Doors.
- 6' 0" wide transoms are used above 6068, 60610 or 6080 Hinged Outswing Patio Doors.
- 7' 7" wide transoms are used above 5068/50610/5080 Hinged Outswing Patio Doors with 2668/26610/2680 Sidelights.
- 8' 1" wide transoms are used above 5468/54610/5480 Hinged Outswing Patio Doors with 2868/28610/2880 Sidelights.
- 9' 1" wide transoms are used above 6068/60610/6080 Hinged Outswing Patio Doors with 3068/30610/3080 Sidelights.

The light patterns illustrated apply to removable interior wood grilles, Full Divided Light, Simulated Divided Light, Decorelle 100, 150 and 400 and Finelight™ Grilles-Between-the-Glass. All removable interior wood grilles will be installed in the units unless otherwise specified. The staggered light patterns illustrated align with light patterns in double doors. Other light patterns are available upon request.

## Single Arch Outswing Patio Door & Sidelight Sizes

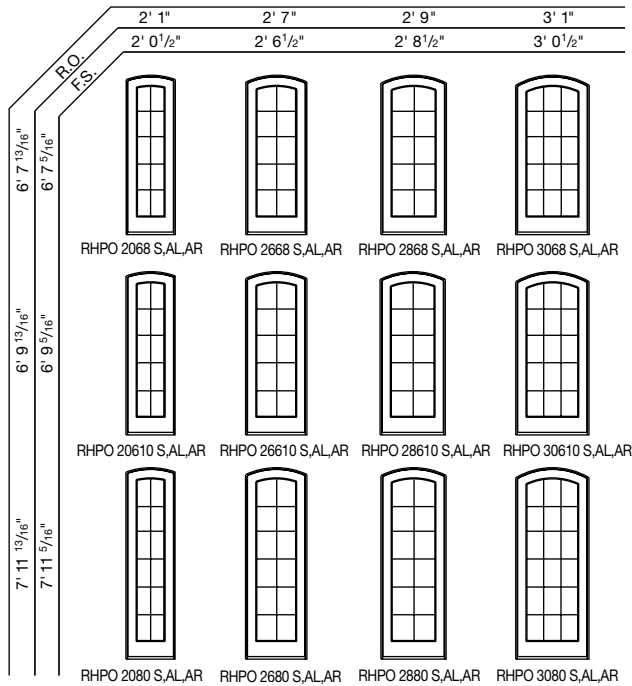

### NOTES

All doors and sidelights use safety/tempered glass.

Single doors have a 3' 0" radius.

Double doors have a 5' 0" radius.

See handing chart on page 132 for operation options.

Use structural joining material when necessary or required by code.

The light patterns illustrated apply to removable interior wood grilles, Full Divided Light, Simulated Divided Light, Decorelle 100, 150 and 400 and Finelight™ Grilles-Between-the-Glass. All removable interior wood grilles will be installed in the units unless otherwise specified.

For a metric conversion in millimeters, multiply dimensions in inches by 25.4.

### Outswing Frame Height Formula (using Low Threshold Sill)

$$= \text{Standard Outswing Frame Height} - 7/16''$$

### FORMULA FOR COMBINATION DOORS

The overall frame dimension (both width and height) is equal to the sum of the individual unit frame dimensions plus joining material dimension(s).

The overall rough opening (both width and height) is equal to the overall frame dimensions plus 1/4" on all sides.

Any unit within each combination can be operating or stationary except for direct-set units and transoms.

## Double Arch Outswing Patio Door Sizes

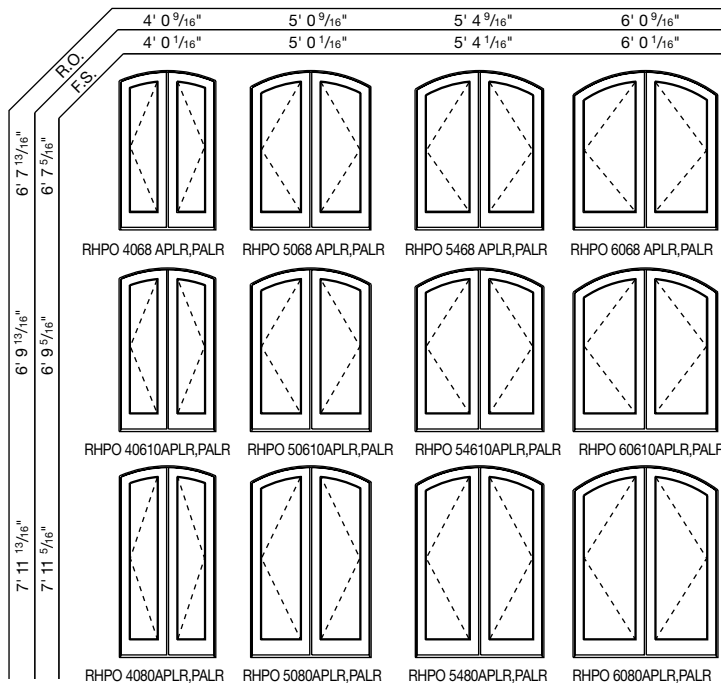

### 3-Wide Arch Outswing Patio Door & Sidelight Sizes

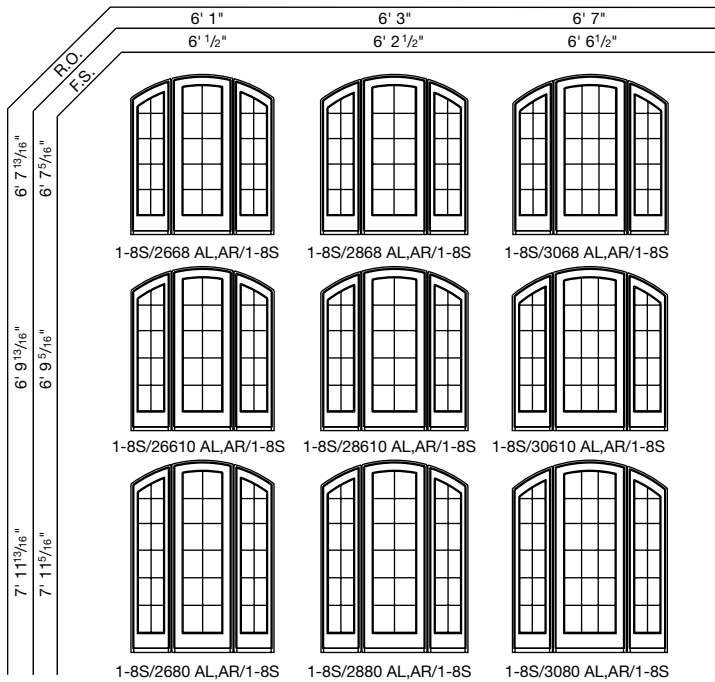

**NOTES**

All doors and sidelights use safety/tempered glass.

3-wide doors have a 5' 0" radius.

CPS doors shown with optional mid-rail.

See handing chart on page 132 for operation options.

Use structural joining material when necessary or required by code.

The light patterns illustrated apply to removable interior wood grilles, Full Divided Light, Simulated Divided Light, Decorelle 100, 150 and 400 and Finelight™ Grilles-Between-the-Glass. All removable interior wood grilles will be installed in the units unless otherwise specified.

For a metric conversion in millimeters, multiply dimensions in inches by 25.4.

**Outswing Frame Height Formula\*  
(using Low Threshold Sill)**

= Standard Outswing Frame Height - 7/16"

\*Does not apply to Concealed Panic System (CPS) doors

**FORMULA FOR COMBINATION DOORS**

The overall frame dimension (both width and height) is equal to the sum of the individual unit frame dimensions plus joining material dimension(s).

The overall rough opening (both width and height) is equal to the overall frame dimensions plus 1/4" on all sides.

Any unit within each combination can be operating or stationary except for arch sidelights.

### Concealed Panic System (CPS) Door Sizes

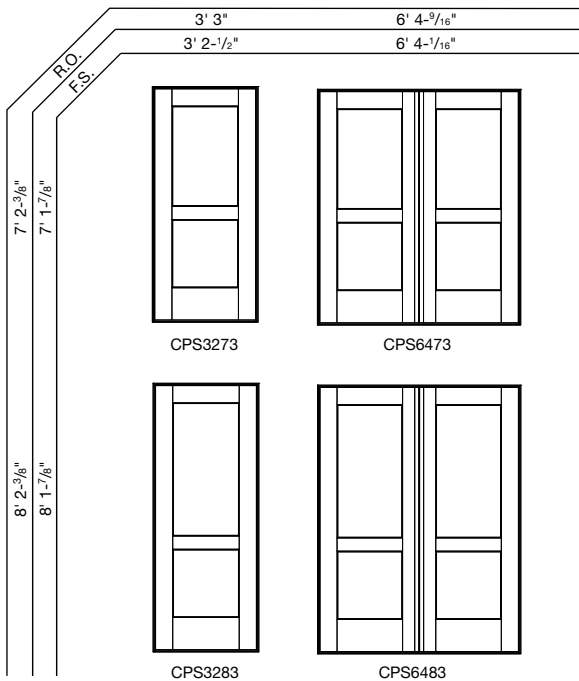



## Hinged Outswing Patio Doors

### Hinged Outswing Patio Door

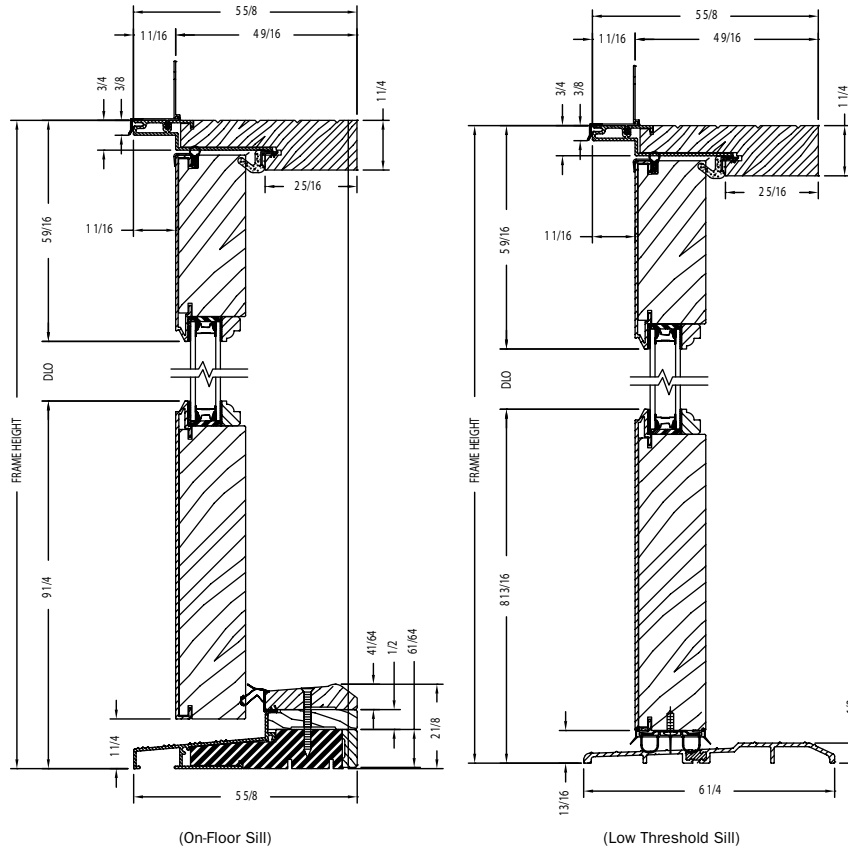

### Astragal

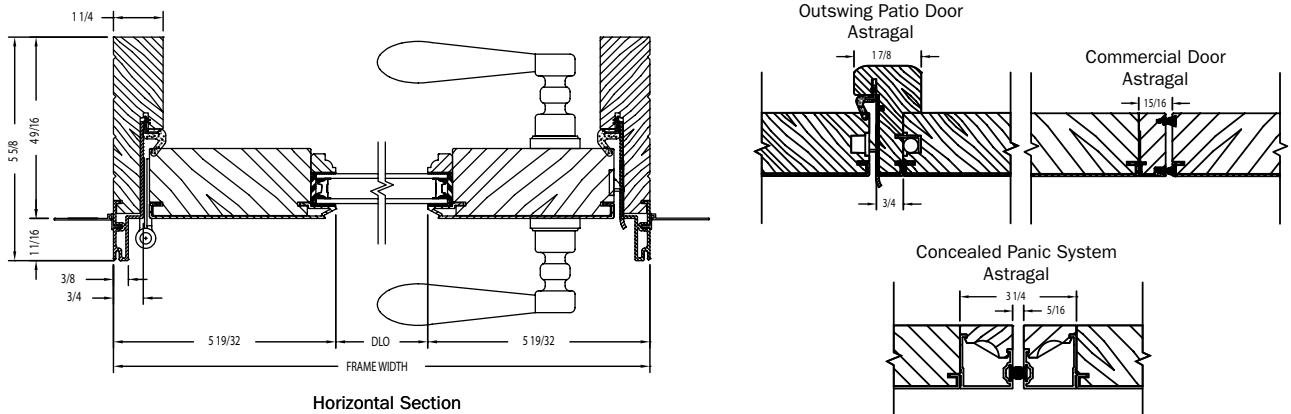

Shown with ovolo (colonial) glass stops.  
French panel shown, also available with a contemporary panel.

# Hinged Outswing Patio Doors

## Outswing Sash-Set Sidelight

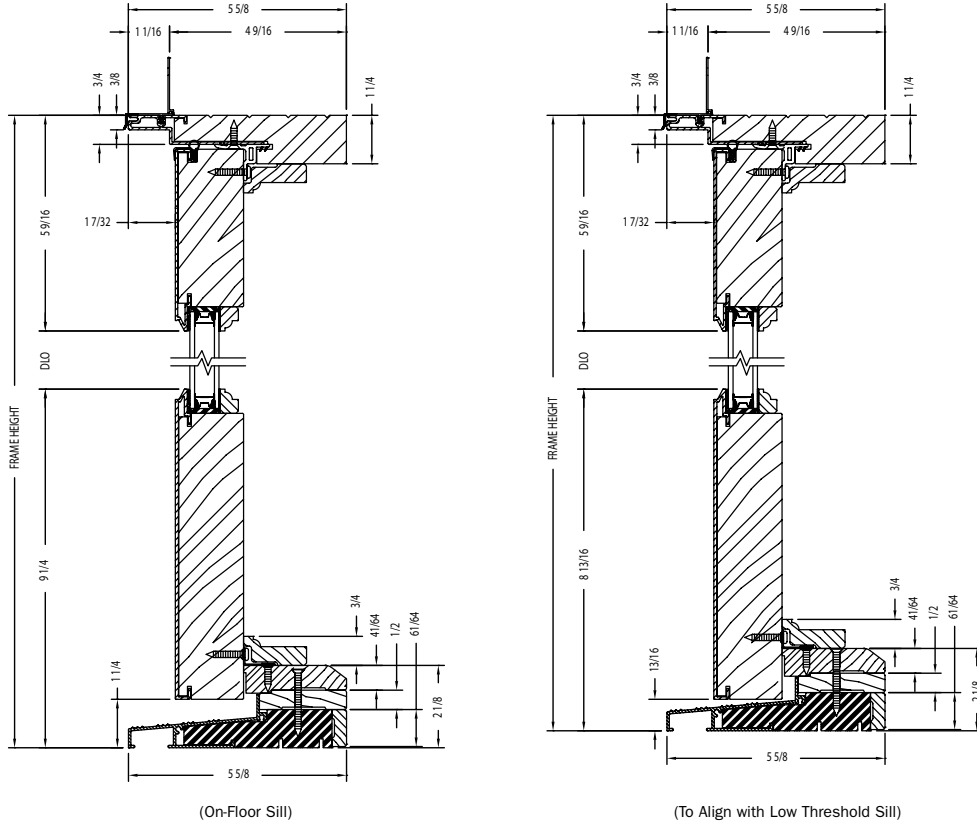

Vertical Section

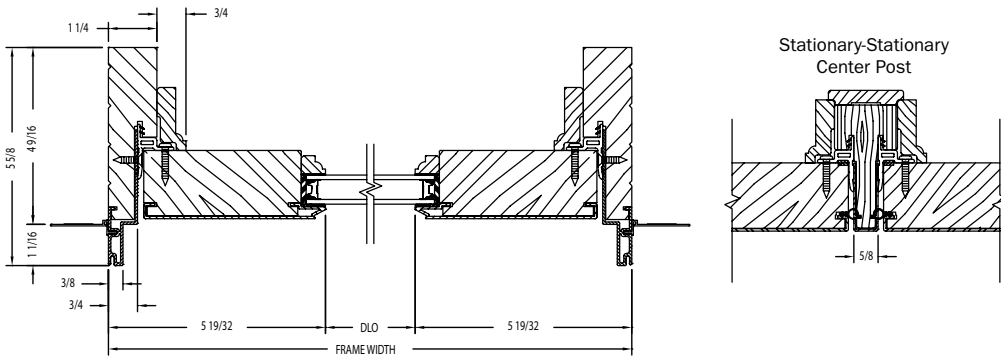

Horizontal Section

Shown with ovolo (colonial) glass stops.

## Hinged Outswing Patio Doors

### Outswing Venting Sidelight

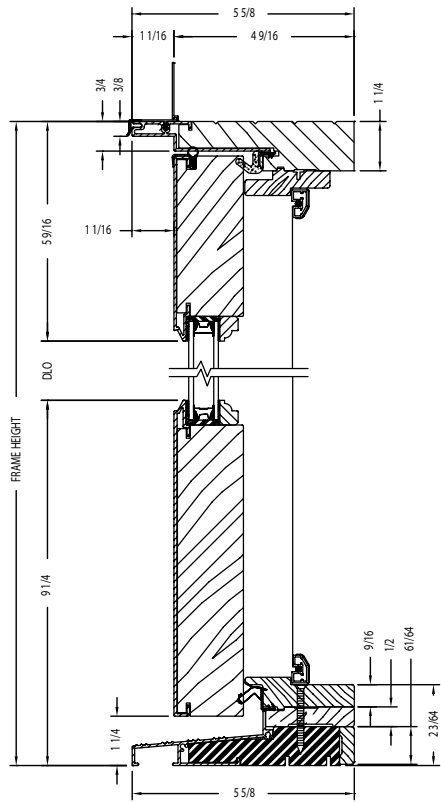

Vertical Section

### Outswing Sash-Set Transom

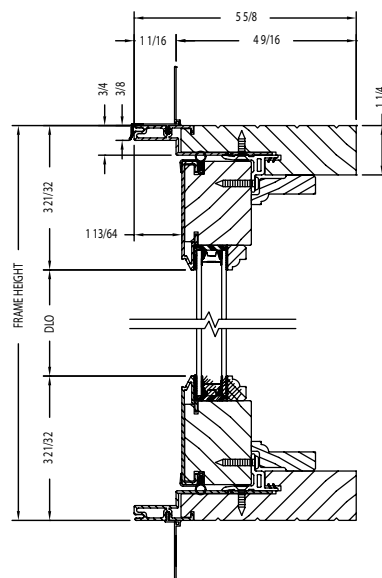

Vertical Section

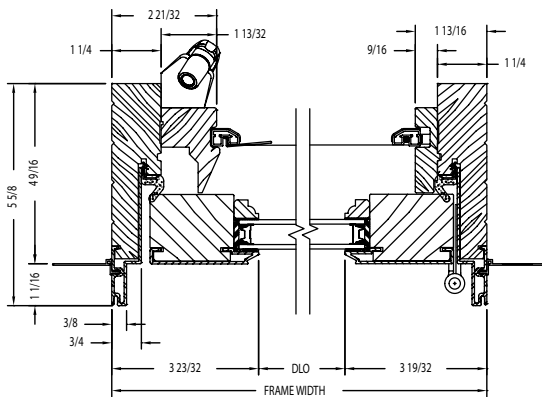

Horizontal Section

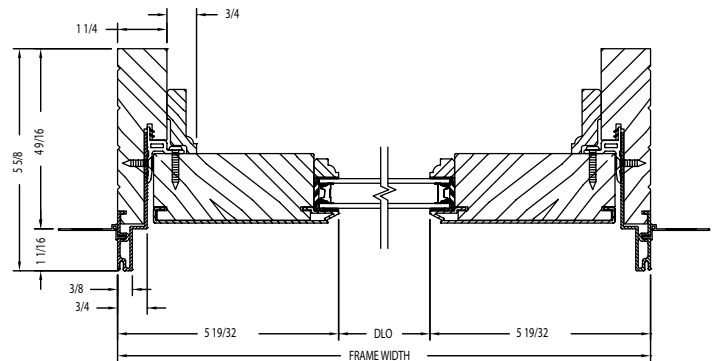

Horizontal Section

Shown with ovolo (colonial) glass stops.

# Gliding Patio Doors

Choose from our French 8" or 12" bottom rail options, or one of two thinner profiles for a more contemporary look, to create an open view to the outside. E-Series gliding patio doors feature multi-point locking hardware for a firm, secure seal and tandem ball bearing rollers for smooth operation.

---

<b>Hinged Overview .....</b>	<b>144</b>
Panel Labeling & Handing .....	146
Gliding Sizing	
Stationary & Two-Panel Doors .....	147
Four-Panel Doors .....	147
Specialty Transoms .....	148
Gliding Details .....	149
French Gliding Sizing	
Stationary & Two-Panel .....	150
Four-Panel .....	151
Specialty Transoms.....	152
French Gliding Details .....	153
Installation Materials .....	154
Product Performance .....	158



E-Series gliding patio door with white interior.



# Gliding Patio Doors



## Frame & Panel

❶ Select wood components are kiln dried and treated with water/insect repellent and preservative. Interior wood surfaces are available in pine, mixed grain Douglas fir, cherry, hickory, mahogany,\* maple, oak, walnut, alder or vertical grain Douglas fir. Interior surfaces are available unfinished or factory primed. Optional factory-applied finishes are available in a variety of stain and paint options.

❷ Wood components are fitted with aluminum extrusions on the exterior. 50 exterior colors that meet AAMA 2604 and 2605 specifications are available, as well as custom colors. Also available is a selection of seven exterior anodized options.

## Sill

❸ A durable fiberglass sill is an excellent thermal barrier. Stainless steel roller caps provide smooth operation of the door panel. Available in dark bronze or gray.

## Glazing

❹ High-Performance Low-E4\* glass with a low-conductivity spacer. Triple-pane glass, tinted, clear dual-pane, high-altitude glass and other special glazing options are available.

❺ Glass is fixed in place from the interior with wood stops that can be removed for easy reglazing if necessary. Glass stops available in ovolo (colonial) or contemporary profiles.

## Weatherstrip

The frame consists of foam-filled leaf weatherstrip on the exterior creating a weather-resistant pocket for the door panel. A dual weatherstrip seal on the interlock is fitted between the fixed and operating meeting stiles.

## Door Anchorage

Vinyl installation flanges are pre-applied into a kerf on the frame exterior to facilitate installation. Optional aluminum flanges or metal installation clips are available. Standard jamb depth is 4 5/16" for gliding patio doors.

## Hardware



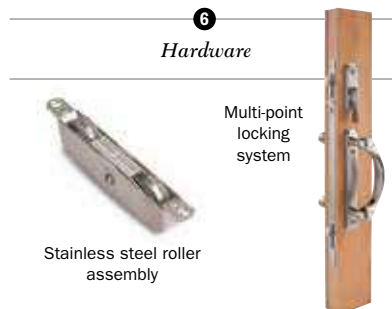













❻ Operating panel consists of two tandem ball bearing steel roller assemblies. Stainless steel roller assemblies are available as an option. The multi-point locking system features a unique reachout design that pulls the door panel tightly closed for a weather-tight seal and enhanced security.



❼ Gliding patio door hardware is available in eight different designs to match virtually any style. Yuma®, Encino®, Anvers®, Newbury®, Covington™ and Whitmore® hardware options each feature solid,

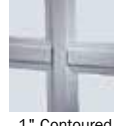

## Features & Options

7 Handle Sets				8 Grilles		
						
<b>Yuma*</b> Distressed Bronze <b>Distressed Nickel</b>	<b>Encino*</b> Distressed Bronze Distressed Nickel	<b>Covington™</b> Antique Brass <b>Bright Brass</b> Oil Rubbed Bronze	<b>Whitmore*</b> <b>Antique Brass</b> Bright Brass Oil Rubbed Bronze Satin Nickel	<b>5/8" FDL</b>	<b>7/8" FDL</b>	<b>1 1/8" FDL</b>
						
<b>Anvers*</b> Bright Brass Oil Rubbed Bronze <b>Satin Nickel</b>	<b>Newbury*</b> Antique Brass Bright Brass Brushed Chrome <b>Oil Rubbed Bronze</b> Polished Chrome Satin Nickel	<b>Albany</b> Black <b>Gold Dust</b> Stone White	<b>Tribeca*</b> Stone <b>White</b>	<b>1 1/2" FDL</b>	<b>7/8" SDL</b>	<b>7/8" Removable</b>
						
				<b>5/8" Flat</b>	<b>1" Contoured</b>	
				FDL = Full Divided Light* SDL = Simulated Divided Light* Removable = Removable interior wood grilles Flat = Finelight™ grilles-between-the-glass Contoured = Finelight grilles-between-the-glass		
9 Blinds-Between-the-Glass						
						

drop-forged brass for added strength, while Albany and Tribeca® hardware options are made of diecast zinc with durable powder-coated finishes. Additional hardware options such as exterior keyed locks and more are also available.

### Auxiliary Foot Lock

An enhanced foot lock is discreetly positioned on the side of the panel. Foot lock provides an extra measure of security when door is in locked position. Available in finish options to complement handle sets.



### Sensors

VeriLock® sensors are unique as they detect whether the doors are locked or unlocked\*\* — a feature no other sensors can provide. See pages 27 and 29 for Smart Home options.

### Insect Screens

**Top-Hung Gliding Insect Screen.** Charcoal fiberglass screen mesh fits into an aluminum frame in 50 exterior colors. Aluminum screen mesh is also available.

**Retractable Insect Screens.** The retractable insect screen has charcoal fiberglass screen mesh. Insect screen retracts when not needed, providing an unobstructed view through the glass. Available in 50 exterior colors. See page 24 for more information on our insect screen options.

### 8 Grilles

**Full Divided Light.** Permanent interior and exterior grilles with grille spacer bars between two panes of glass. Available in 5/8", 7/8", 1 1/8", 1 1/2" or 2 1/4" widths and ovolo or contemporary profiles.

**Simulated Divided Light.** Permanent exterior and interior grilles without grille spacer bars. Available in 5/8", 7/8", 1 1/8", 1 1/2" or 2 1/4" widths and ovolo or contemporary profiles.

**Finelight™ Grilles-Between-the-Glass.** Available in 5/8" flat or 1" contoured aluminum profiles. Two-tone colors of pebble tan/colony white, sierra bronze/colony white or forest green/colony white are available on the 1" profile.

**Removable interior wood grilles.** Removable interior wood grilles are available in a 7/8" width and ovolo or contemporary profiles. Optional surround for removable grille and permanent exterior grilles also available.

### 9 Privacy Options

**Blinds-Between-the-Glass.** A 5/8" aluminum slat blind mounted between two panes of insulated glass in a dust-free environment. Available in white, tan and almond. Blinds are magnetically controlled and can be tilted or raised and lowered with one cord.†

\* FDL & SDL grille options also available in 2 1/4" width and in contemporary profile. See page 22 for more information.

\*\* When properly configured and maintained with a professionally installed security system and/or self-monitoring system compatible with Honeywell® 5800 controls. See your Andersen supplier for more information.

† Not all sizes are retractable. See your Andersen supplier for details.

Tribeca and Albany hardware are zinc die cast with powder-coated durable finish. Other hardware is solid forged brass.

Distressed bronze and oil rubbed bronze are "living" finishes that will change with time and use.

Mix-and-match interior and exterior style and finish options are available.

Bright brass and satin nickel finishes feature a 10-year limited warranty.

Printing limitations prevent exact finish replication. See your Andersen supplier for actual finish samples.

# Gliding Patio Door Panel Labeling

## Door Panel Options

Andersen® E-Series offers both contemporary and French panel styles to complement traditional or modern architecture.

Gliding Patio Door Contemporary Panels

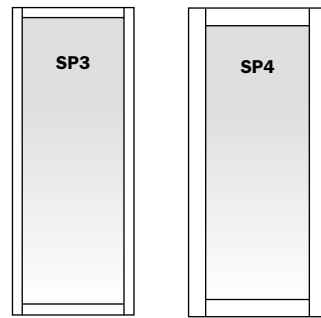

2 3/4" stiles & rails

4 1/16" stiles & rails

Gliding Patio Door French Panels

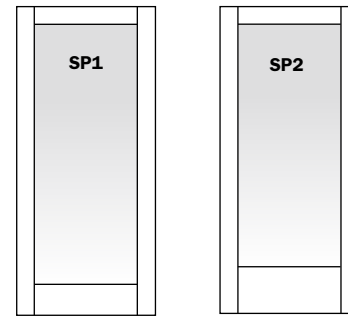

4 1/16" stiles, 4 1/16" top rail & 8" bottom rail

4 1/16" stiles, 4 1/16" top rail & 12" bottom rail

# Gliding Patio Door Handing

The door handing and order designation noted below is consistent with the handing of other Andersen® gliding patio doors and is used throughout the remainder of the gliding patio doors section.

## Identification

As viewed from the exterior, either the left or the right panel operates. The arrow designates the direction of panel operation. Stationary (S) doors can be used as an individual unit or as a sidelight.

## Gliding Patio Doors & French Gliding Patio Doors

### Handing Options

#### Single Door

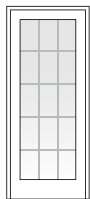

S

Stationary Panel

#### 2-Panel Door

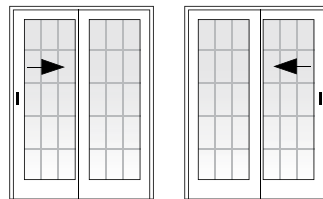

LS

Left (L) panel is operating, right panel is stationary (S).

SR

Left panel is stationary (S), right (R) panel is operating.

#### 4-Panel Door

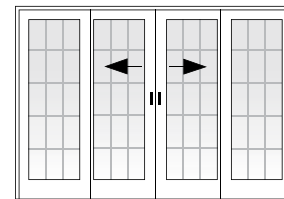

Astragal is attached on third panel from the left (as viewed from the exterior)

### Order Designation Description

	As Viewed From Exterior
Stationary	S
2-Panel Door	SR
	LS
4-Panel Door	—



### Gliding Patio Door Sizes

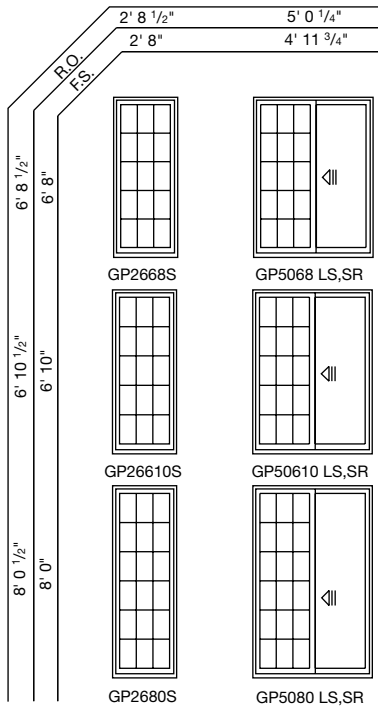

### Gliding Patio Door Sizes

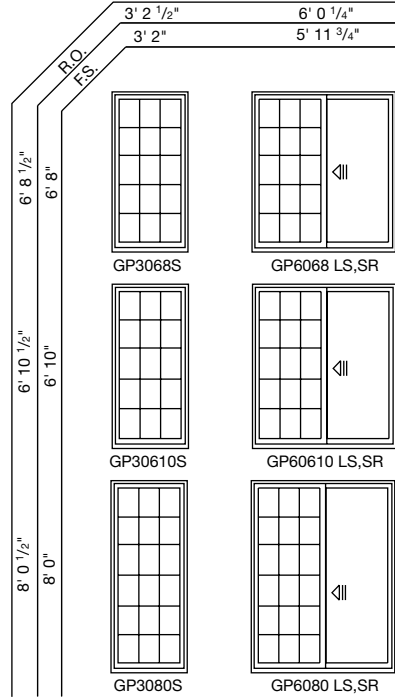

**NOTES**

All doors and sidelights use safety/tempered glass.

Astragal is applied to third panel from the left (as viewed from the exterior) on a 4-panel gliding patio door.

\*\*4-panel doors are shipped knocked down and require field assembly because of size and weight.

Use structural joining material when necessary or required by code.

The light patterns illustrated apply to removable interior wood grilles, Full Divided Light, Simulated Divided Light, Decorelle 100, 150 and 400 and FineLight™ Grilles-Between-the-Glass. All removable interior wood grilles will be installed in the units unless otherwise specified.

For a metric conversion in millimeters, multiply dimensions in inches by 25.4.

**FORMULA FOR COMBINATION DOORS**

The overall frame dimension (both width and height) is equal to the sum of the individual unit frame dimensions plus joining material dimension(s).

The overall rough opening (both width and height) is equal to the overall frame dimensions plus 1/4" on all sides.

### Gliding Patio Door Sizes

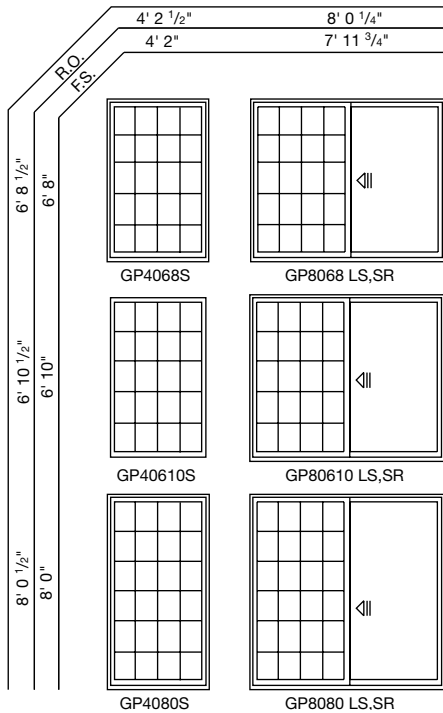

### 4-Panel Gliding Patio Door Sizes

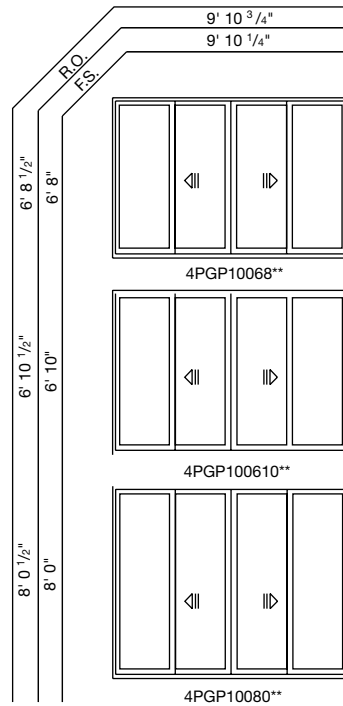

## 4-Panel Gliding Patio Door Sizes

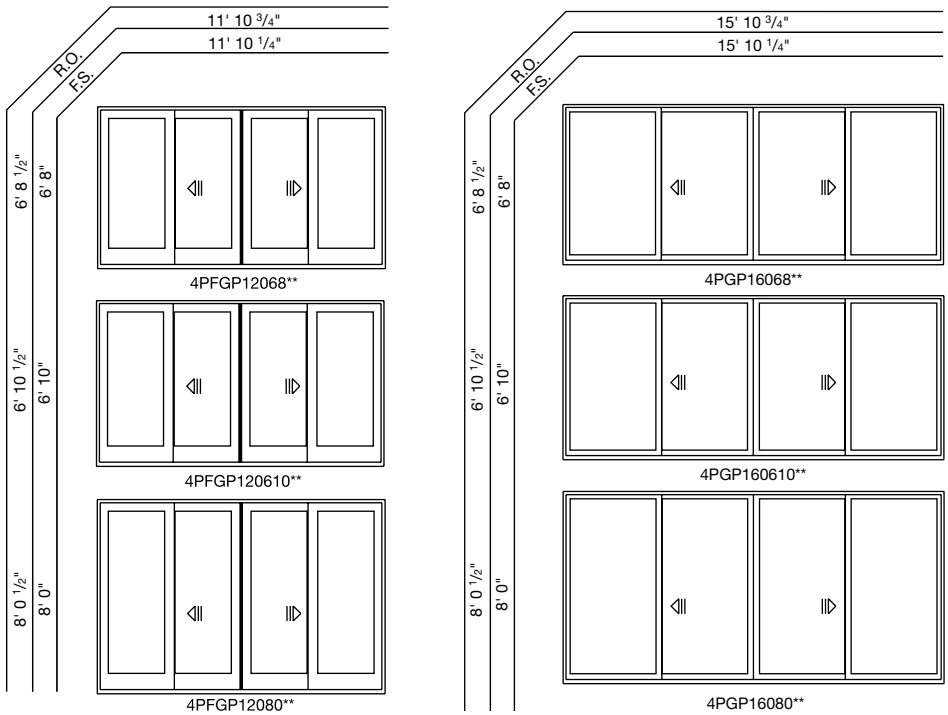

## Gliding Patio Door Direct-Set Elliptical Sizes (Specialty Frame)

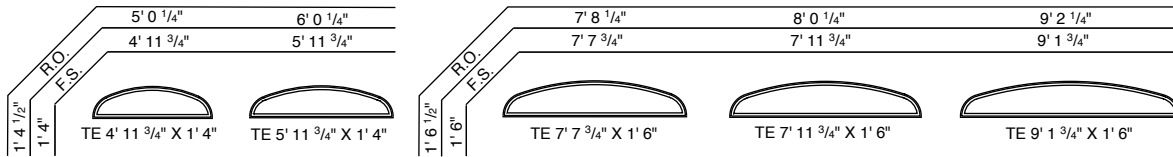

## Gliding Patio Door Direct-Set Transom Sizes (Specialty Frame)

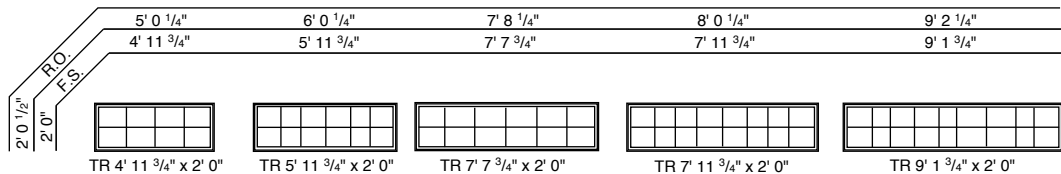

### NOTES

All doors and sidelights use safety/tempered glass.

If glass is positioned within 18" of the finished floor, safety/tempered glass may be required. Local codes may differ. Verify tempered glass requirements with your local building code official.

Astragal is applied to third panel from the left (as viewed from the exterior) on a 4-panel gliding patio door.

\*\*4-panel doors are shipped knocked down and require field assembly because of size and weight.

See transom notes on page 149.

Use structural joining material when necessary or required by code.

The light patterns illustrated apply to removable interior wood grilles, Full Divided Light, Simulated Divided Light, Decorelle 100, 150 and 400 and Finelight™ Grilles-Between-the-Glass. All removable interior wood grilles will be installed in the units unless otherwise specified. The staggered light patterns illustrated align with light patterns for the gliding door. Other light patterns are available upon request.

For a metric conversion in millimeters, multiply dimensions in inches by 25.4.

### FORMULA FOR COMBINATION DOORS

The overall frame dimension (both width and height) is equal to the sum of the individual unit frame dimensions plus joining material dimension(s).

The overall rough opening (both width and height) is equal to the overall frame dimensions plus 1/4" on all sides.

### Gliding Patio Door Direct-Set Half Circle Sizes (Specialty Frame)

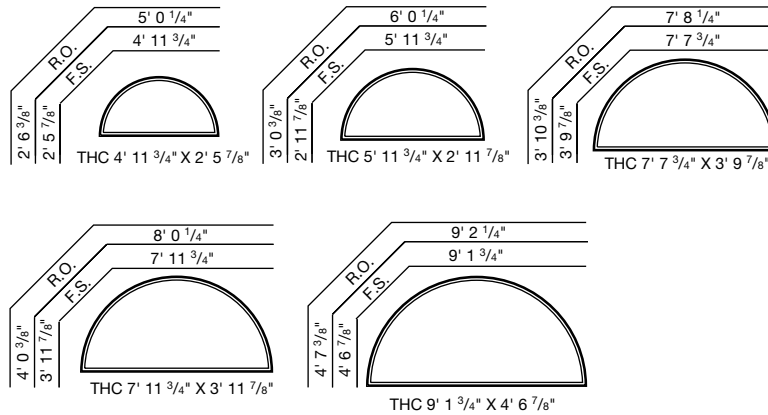

**NOTES**

4' 11-3/4" wide units are used above 5068, 50610 or 5080 Gliding Patio Doors.

5' 11-3/4" wide units are used above 6068, 60610 or 6080 Gliding Patio Doors.

7' 7-3/4" wide units are used above 7668, 76610 or 7680 Gliding Patio Doors.

7' 11-3/4" wide units are used above 8068, 80610 or 8080 Gliding Patio Doors.

9' 1-3/4" wide units are used above 9068, 90610 or 9080 Gliding Patio Doors.

See notes on page 148 for more information.

### Gliding Patio Doors

#### Astragal

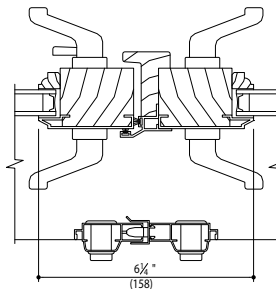

Contemporary door panel shown with ovolo (colonial) glass stops.

Dimensions in parentheses are in millimeters.

#### Gliding Patio Door

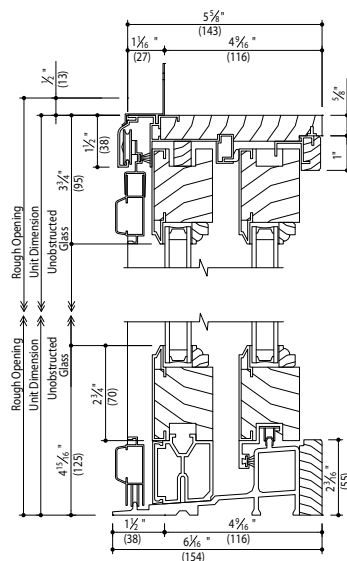

Vertical Section

#### Gliding Patio Door Sidelight

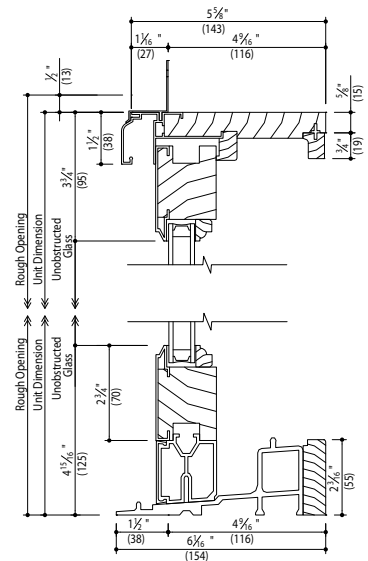

Vertical Section

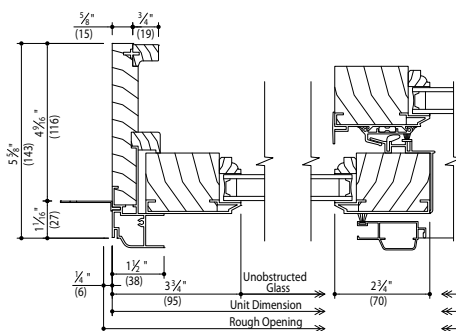

Horizontal Section

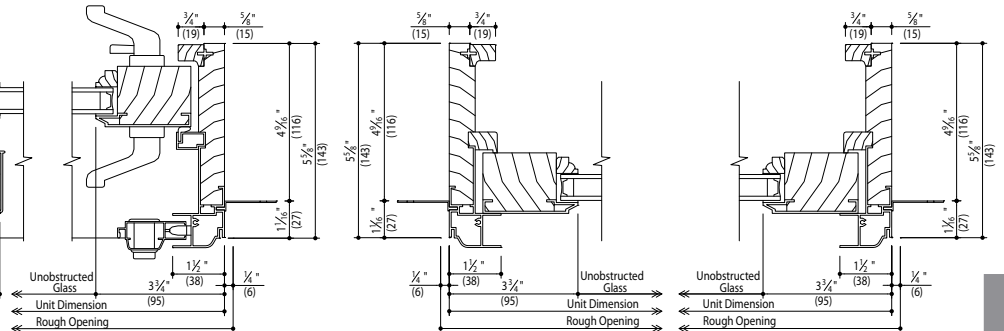

Horizontal Section

**FOR WINDOWS OVER 30 SQUARE FEET OR RATED HIGHER THAN PG50, ONE OF THESE THREE INSTALLATION METHODS IS REQUIRED: A) THROUGH THE JAMB B) ALUMINUM NAILING FLANGE OR C) INSTALLATION CLIPS. ADDITIONAL CUSTOM SIZES ARE AVAILABLE. CONTACT YOUR LOCAL SUPPLIER FOR MORE INFORMATION. DRAWINGS ARE NOT TO SCALE. WRITTEN INSTALLATION INSTRUCTIONS THAT PROVIDE GUIDELINES FOR PROPER INSTALLATION ARE AVAILABLE BY VISITING ANDERSENWINDOWS.COM. CUSTOM SIZES ARE AVAILABLE. CONTACT YOUR LOCAL SUPPLIER FOR MORE INFORMATION. DRAWINGS ARE NOT TO SCALE.**

## French Gliding Patio Door Sizes

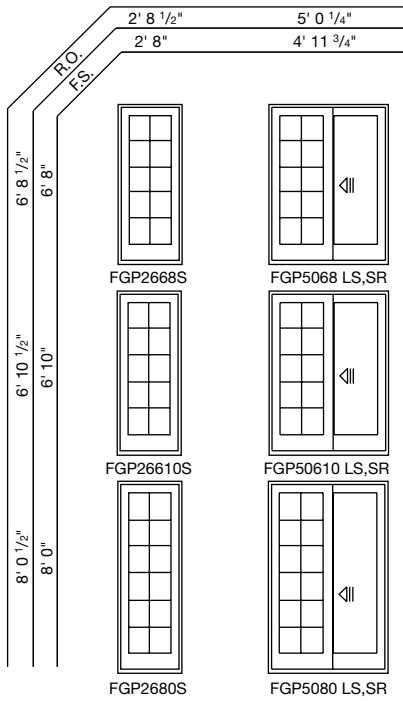

### NOTES

All doors and sidelights use safety/tempered glass.

Use structural joining material when necessary or required by code.

The light patterns illustrated apply to removable interior wood grilles, Full Divided Light, Simulated Divided Light, Decorelle 100, 150 and 400 and Finelight™ Grilles-Between-the-Glass. All removable interior wood grilles will be installed in the units unless otherwise specified.

For a metric conversion in millimeters, multiply dimensions in inches by 25.4.

### FORMULA FOR COMBINATION DOORS

The overall frame dimension (both width and height) is equal to the sum of the individual unit frame dimensions plus joining material dimension(s).

The overall rough opening (both width and height) is equal to the overall frame dimensions plus 1/4" on all sides.

## French Gliding Patio Door Sizes

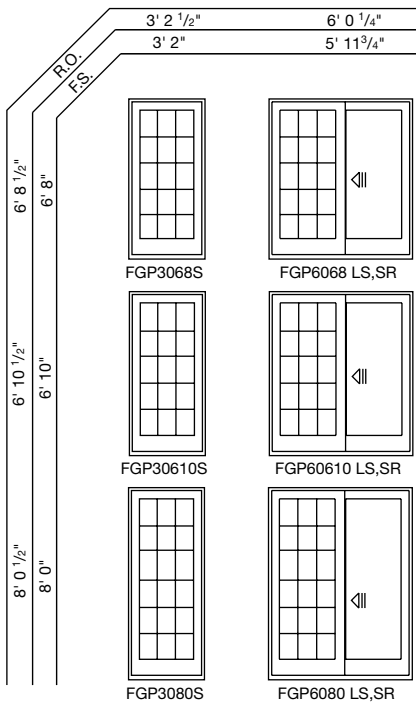



### French Gliding Patio Door Sizes

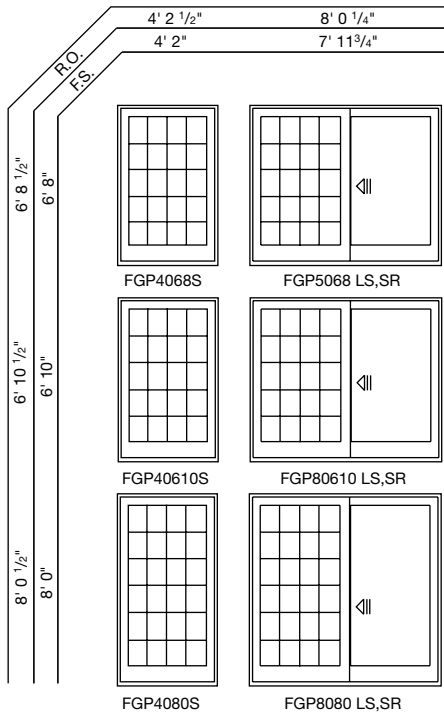

### 4-Panel French Gliding Patio Door Sizes

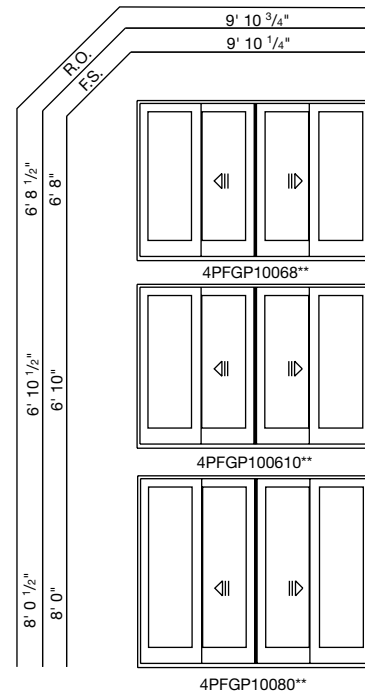

### 4-Panel French Gliding Patio Door Sizes

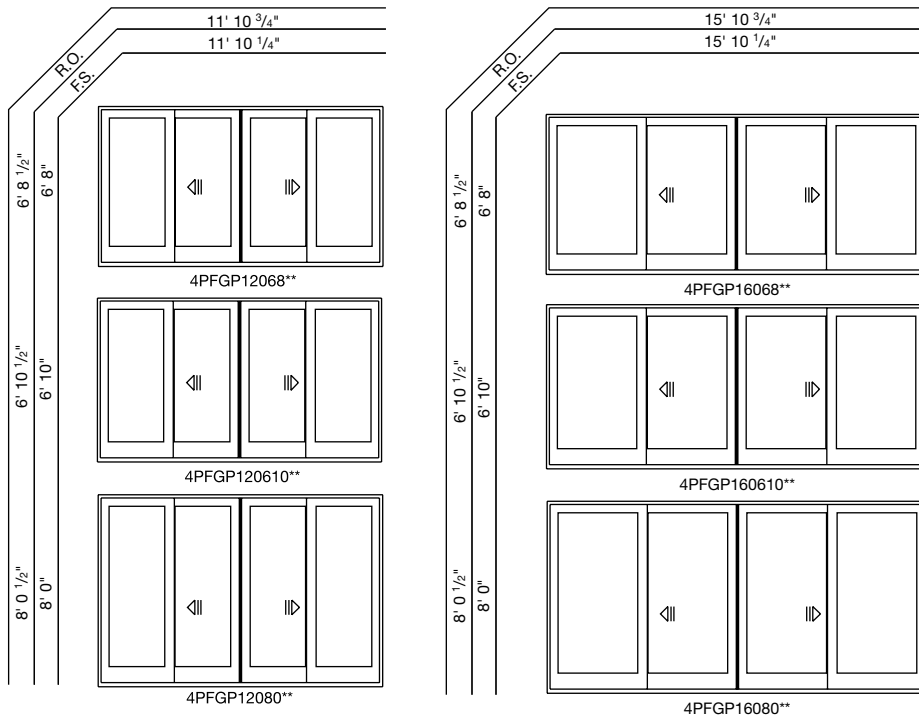

**NOTES**

All doors and sidelights use safety/tempered glass.

Astragal is applied to third panel from the left (as viewed from the exterior) on a 4-panel French gliding patio door.

\*\* 4-panel doors are shipped knocked down and require field assembly because of size and weight.

See notes on page 150 for more information.

## French Gliding Patio Door Direct-Set Transom Sizes (Specialty Frame)

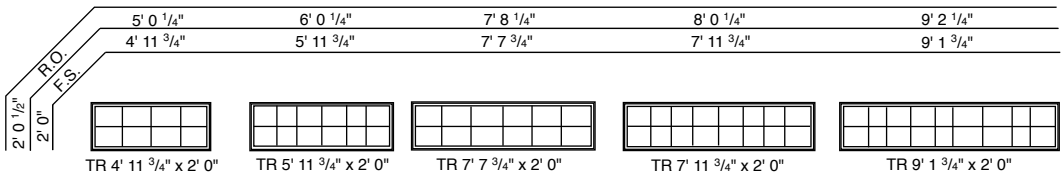

## French Gliding Patio Door Direct-Set Elliptical Sizes (Specialty Frame)

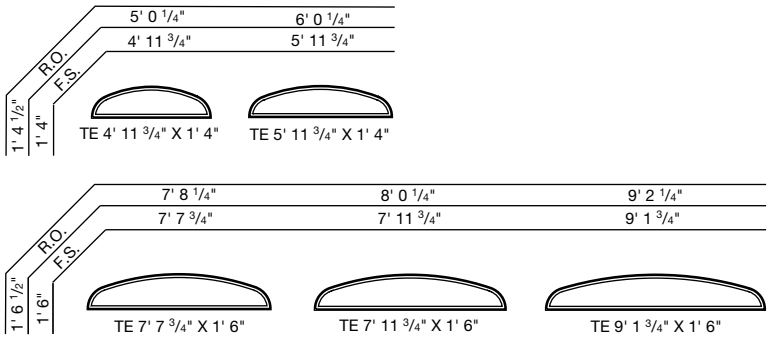

## French Gliding Patio Door Direct-Set Half Circle Sizes (Specialty Frame)

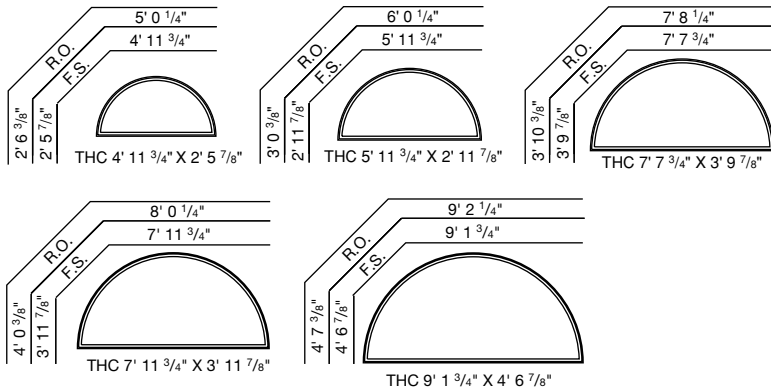

### NOTES

All doors and sidelights use safety/tempered glass.

If glass is positioned within 18" of the finished floor, safety/tempered glass may be required. Local codes may differ. Verify tempered glass requirements with your local building code official.

4' 11-3/4" wide units are used above 5068, 50610 or 5080 French Gliding Patio Doors.

5' 11-3/4" wide units are used above 6068, 60610 or 6080 French Gliding Patio Doors.

7' 7-3/4" wide units are used above 7668, 76610 or 7680 French Gliding Patio Doors.

7' 11-3/4" wide units are used above 8068, 80610 or 8080 French Gliding Patio Doors.

9' 1-3/4" wide units are used above 9068, 90610 or 9080 French Gliding Patio Doors.

Use structural joining material when necessary or required by code.

The light patterns illustrated apply to removable interior wood grilles, Full Divided Light, Simulated Divided Light, Decorelle 100, 150 and 400 and Finelight™ Grilles-Between-the-Glass. All removable interior wood grilles will be installed in the units unless otherwise specified. The staggered light patterns illustrated align with light patterns in the gliding door. Other light patterns are available upon request.

For a metric conversion in millimeters, multiply dimensions in inches by 25.4.

### FORMULA FOR COMBINATION DOORS

The overall frame dimension (both width and height) is equal to the sum of the individual unit frame dimensions plus joining material dimension(s).

The overall rough opening (both width and height) is equal to the overall frame dimensions plus 1/4" on all sides.

## French Gliding Patio Doors

### French Gliding Patio Door

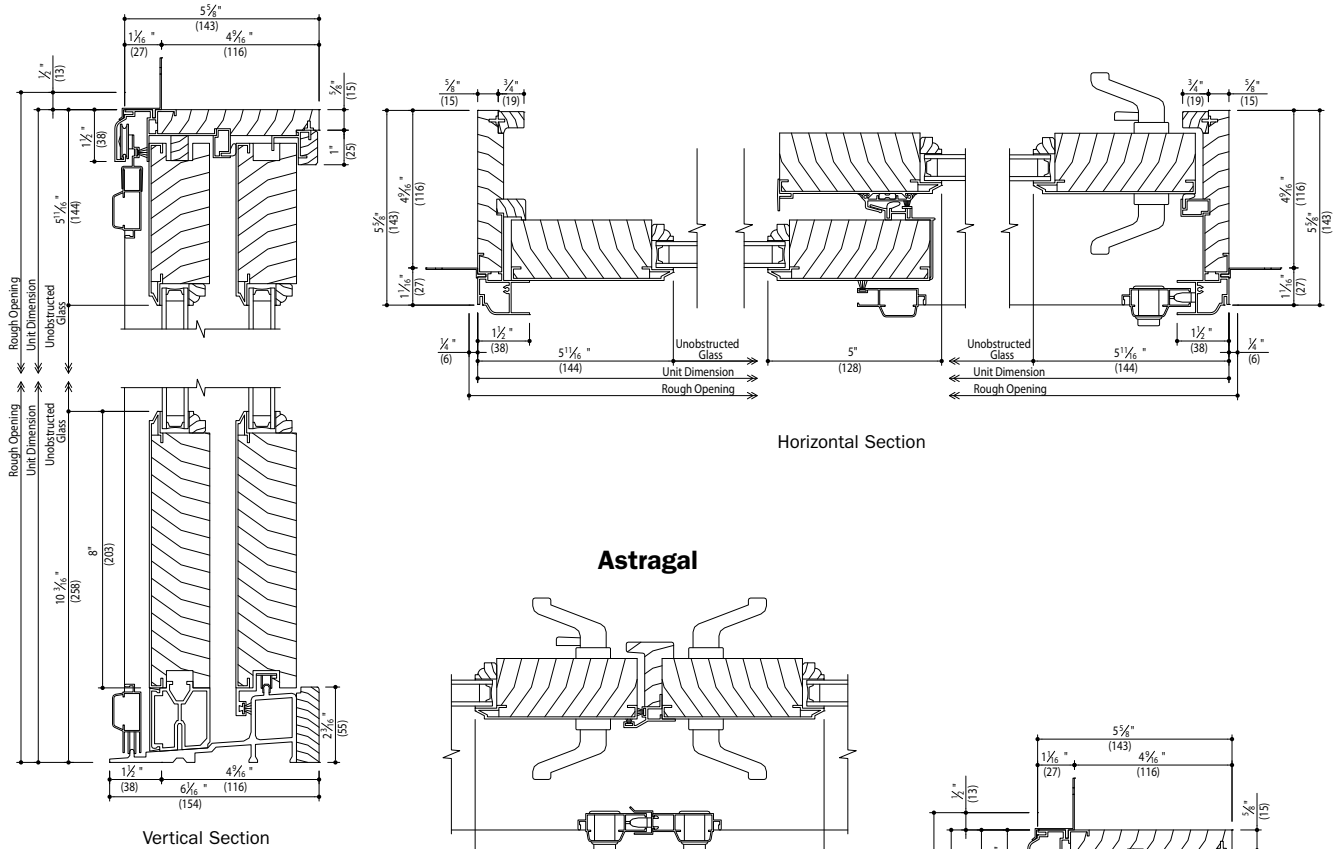

Shown with ovolo (colonial) glass stops.  
Door panel with 8" bottom rail shown, also available with 12" bottom rail.  
Dimensions in parentheses are in millimeters.

### French Gliding Patio Door Sidelight

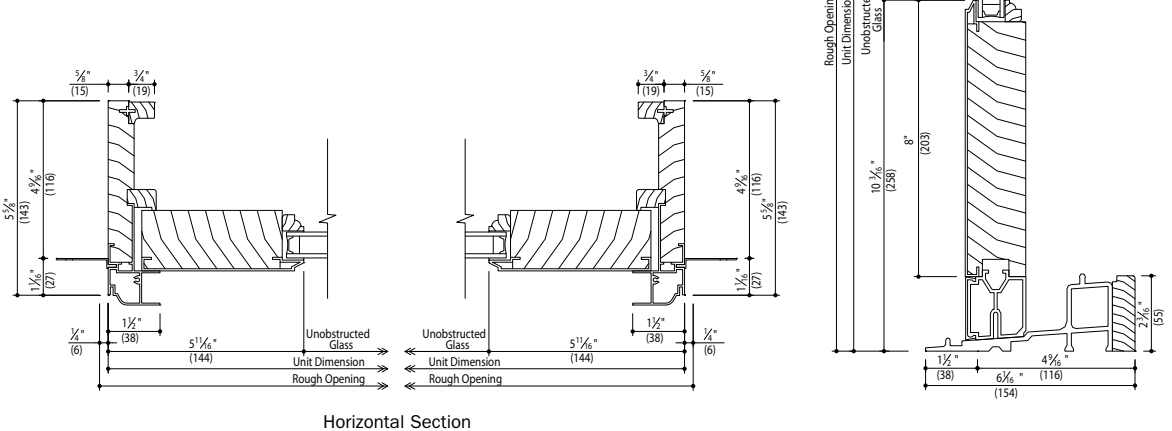

# Installation Materials

We offer a variety of accessory metals to ensure a coordinated, low-maintenance window or door system. Available in 50 exterior colors at no additional cost, these trims save time on the job site.

## Joining Components

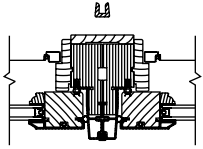

Standard Exterior Mull Cover

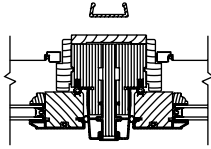

1/2" Exterior Mull Cover

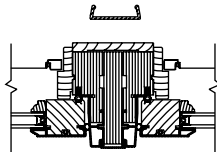

3/4" Exterior Mull Cover

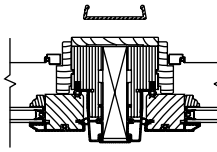

1" Exterior Mull Cover

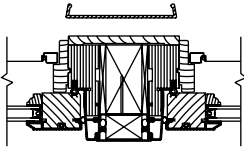

2" Exterior Mull Cover

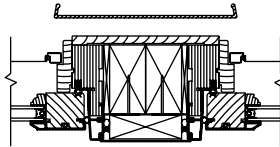

3-1/2" Exterior Mull Cover

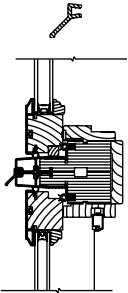

Standard Exterior Mull Cover with Drip

## Bay and Bow Trim Metals & Applications

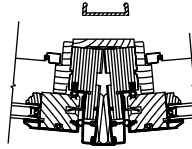

10° Casement Bow Exterior Mull Cover

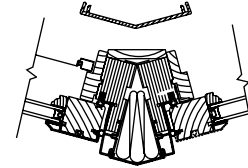

30° Casement Angle Bay Exterior Mull Cover

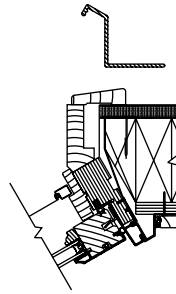

30° Angle Bay Enclosure

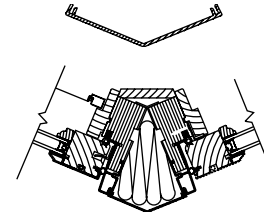

45° Casement Angle Bay Exterior Mull Cover

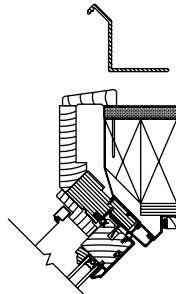

45° Angle Bay Enclosure



30° Angle Bay Exterior Mull Cover



45° Double-Hung Exterior Mull Cover



Trim Metals & Applications

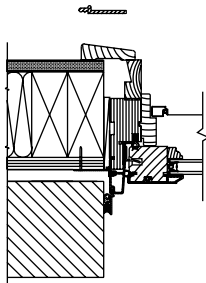

3/4" Frame Extender

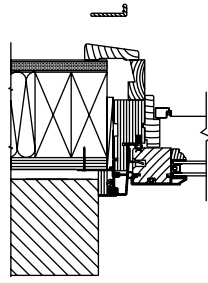

3/4" Frame Expander

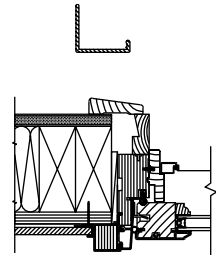

90° Angle Expander

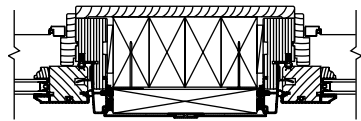

1-1/2" Mull Expander – May be used with adjustable mull covers or frame expanders (vertical joins only)

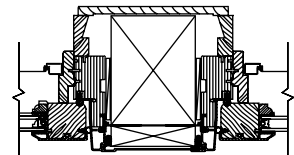

1" - 5" Adjustable Mull Cover and Receiver (vertical join)

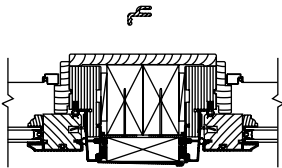

Frame Expander Receiver

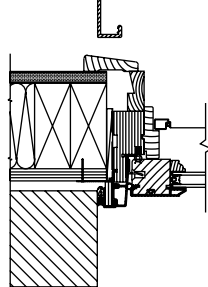

Expander Return

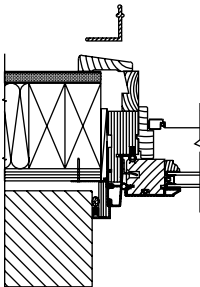

3/4" Frame Enclosure

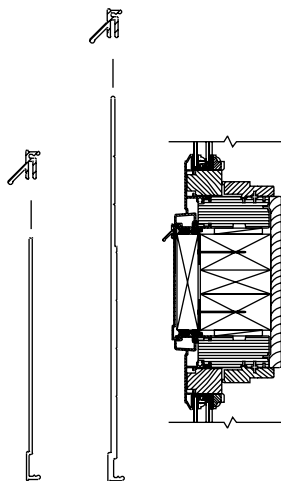

1" - 5" and 5-1/4" - 8" Adjustable Mull Cover and Receiver with Drip Leg (horizontal join)

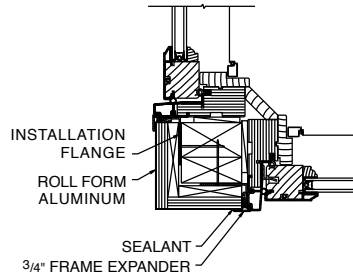

Corner Post Section of Box Bay Using Roll Form Metal on Corners

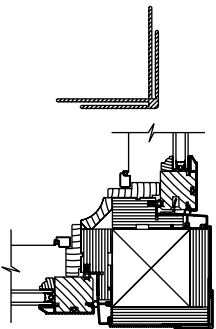

90° Outside Corner



2-1/4" Frame Expander

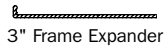

3" Frame Expander

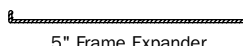

5" Frame Expander

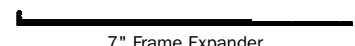

7" Frame Expander

## Applications

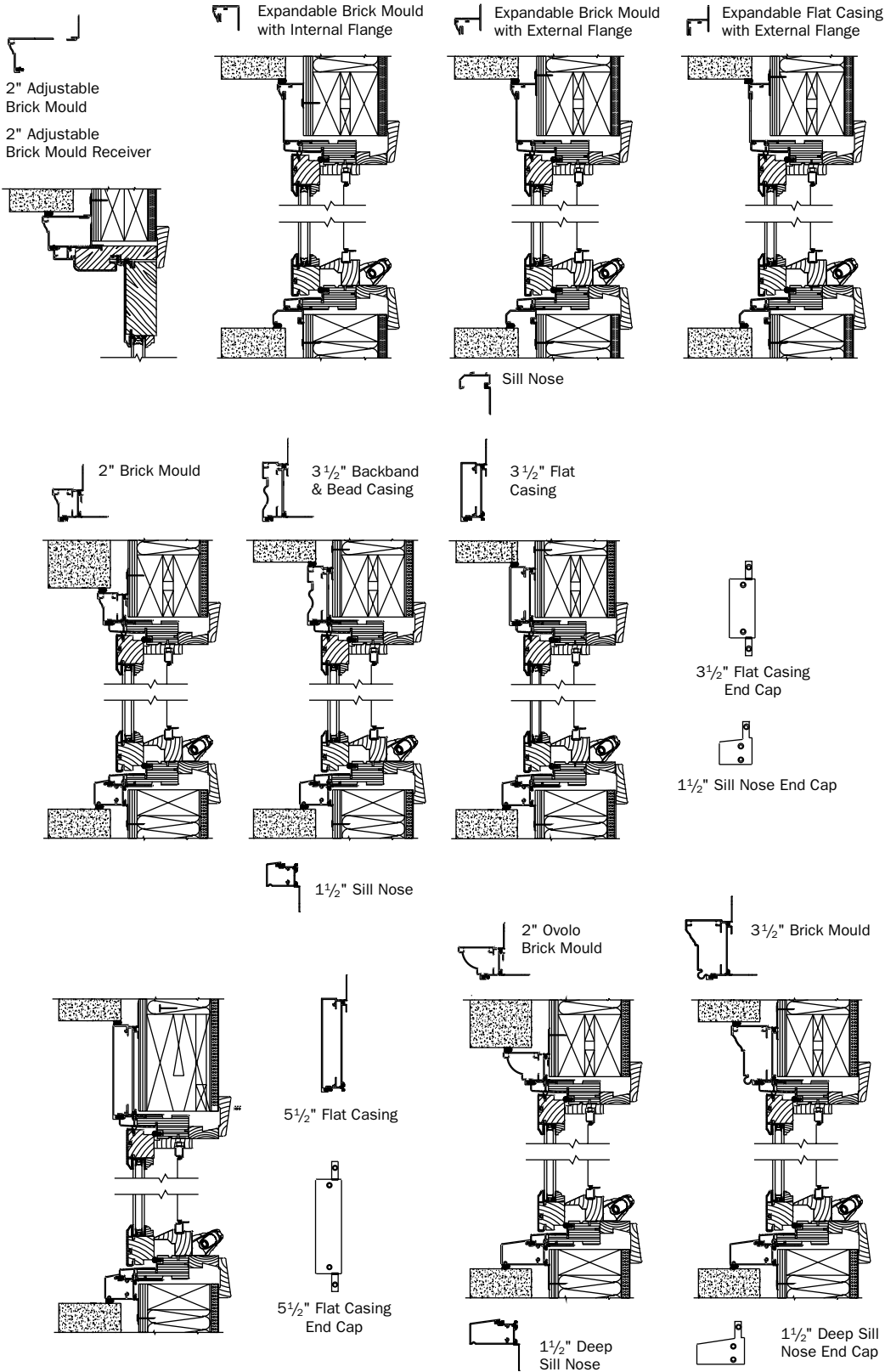

## Drip Caps & Applications

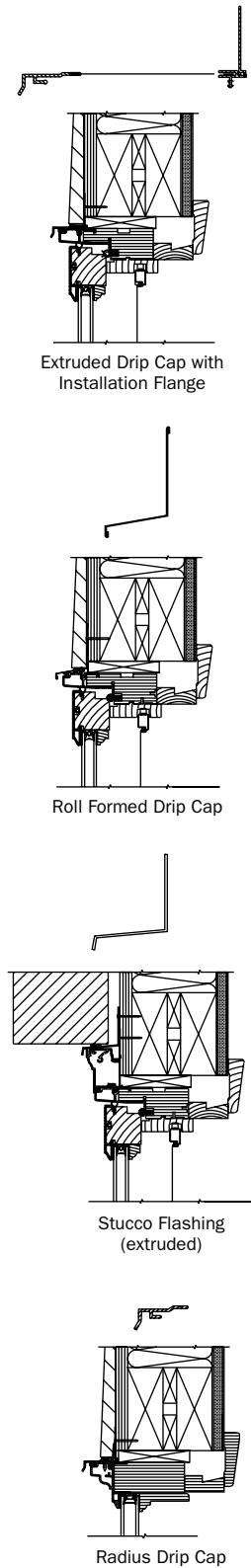

## Miscellaneous Trim Metals & Applications

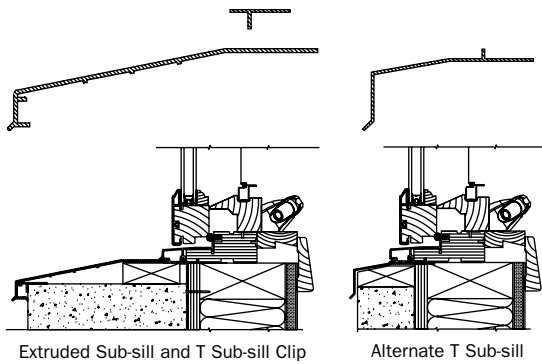

Extruded Sub-sill and T Sub-sill Clip

Alternate T Sub-sill

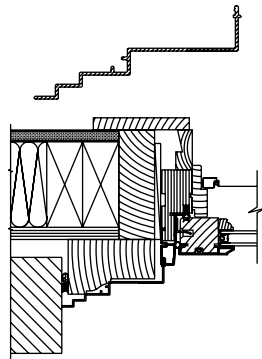

Historical Panning

## Sub-Frame Shell System

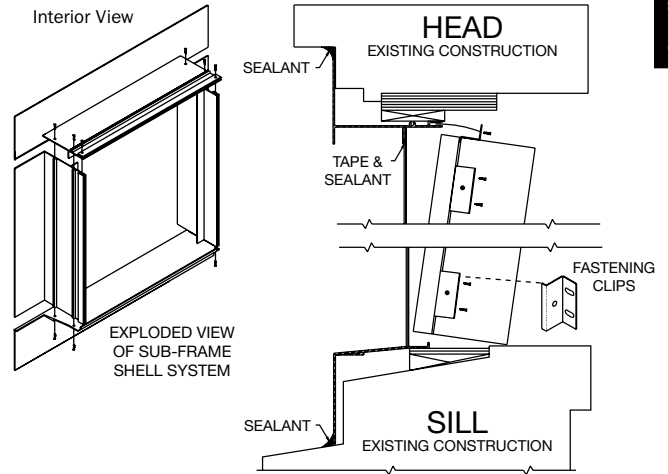

The E-Series Sub-Frame Shell System is a simple and effective way to meet remodeling needs for residential and commercial projects. Preserving existing buildings and neighborhoods has become increasingly important to our society. And a good, sound, older structure can be as efficient as, if not more efficient than, a new building.

Many E-Series products will work in the Sub-Frame Shell System for remodeling, which means you have unlimited design choices to fit the existing architecture. The Sub-Frame Shell System is a heavy aluminum perimeter-flange sub-frame that covers most existing construction conditions. It can be installed from the inside without costly scaffolding or off-staging.

## Masonry Opening Formulas

Masonry Opening Formulas			
Formulas allow 1/4" for backer rod and sealant around entire perimeter			
2" Brick Mould 2" Ovolo Brick Mould	WIDTH		Frame + 3 3/4"
	HEIGHT	w/ Sill Nose	Frame + 3 1/4"
		4-Sides	Frame + 3 3/4"
3 1/2" Flat Casing 3 1/2" Brick Mould 3 1/2" Backband & Bead Casing	WIDTH		Frame + 6 3/4"
	HEIGHT	w/ Sill Nose	Frame + 4 3/4"
		4-Sides	Frame + 6 3/4"
5 1/2" Flat Casing	WIDTH		Frame + 10 3/4"
	HEIGHT	w/ Sill Nose	Frame + 6 3/4"
		4-Sides	Frame + 10 3/4"
	3-Sides	Frame + 5 5/8"	

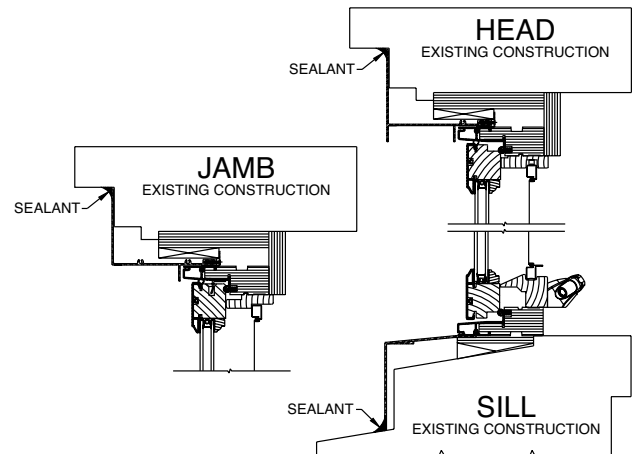

## Performance Grade & Air Infiltration Ratings for E-Series Windows & Patio Doors – Dual-Pane & Triple-Pane Glass

For current performance information, please visit [andersenwindows.com](http://andersenwindows.com).

Andersen® Product	Panel Type	AAMA/WDMA/CSA 101/I.S.2/A440 Performance Grade (PG)	+/- Corresponding Design Pressure (DP)	Air Infiltration CFM/FT <sup>2</sup>
<b>Casement Windows</b>				
Stationary (6060)	-	Class CW-PG50-FW Size Tested 72" x 72"	50/50	≤0.2
Venting (2660)	-	Class CW-PG55-C Size Tested 30" x 72" *	55/55	≤0.2
Venting (3028)	-	Class CW-PG55-C Size Tested 36" x 32"	55/55	≤0.2
Venting (3056)	-	Class CW-PG60-C Size Tested 36" x 66"	60/60	≤0.2
Venting, piano hinge (3060)	-	Class CW-PG70-C Size Tested 36" x 72"	70/70	≤0.2
<b>Awning Windows</b>				
Venting (4030)	-	Class LC-PG50-AP Size Tested 48" x 36"	50/50	≤0.2
Venting (4050)	-	Class LC-PG50-AP Size Tested 48" x 60"	50/50	≤0.2
Venting (4056)	-	Class LC-PG65-AP Size Tested 48" x 66"	65/65	≤0.2
<b>Casement &amp; Awning Picture/Transom Windows</b>				
Fixed (46100) <i>dual-pane glass only</i>	-	Class CW-PG80-FW Size Tested 54" x 120" *	80/80	≤0.2
Fixed (6080) <i>dual-pane glass only</i>	-	Class CW-PG80-FW Size Tested 72" x 96"	80/80	≤0.2
<b>Arch Casement Windows</b>				
Stationary (6060)	-	Class LC-PG50-FW Size Tested 72" x 72"	50/50	≤0.2
Venting (3028)	-	Class CW-PG55-C Size Tested 36" x 32" *	55/55	≤0.2
Venting (3056)	-	Class CW-PG60-C Size Tested 36" x 66"	60/60	≤0.2
Venting (3060)	-	Class CW-PG70-C Size Tested 36" x 72"	70/70	≤0.2
<b>French Casement Windows</b>				
Venting (5050) <i>dual-pane glass only</i>	-	Class LC-PG30-C Tested 60" x 60"	30/30	≤0.2
<b>Push Out Casement Windows</b>				
Venting (3034)	-	Class LC-PG50-C Size Tested 36" x 40"	50/50	≤0.2
Venting (3060)	-	Class LC-PG50-C Size Tested 36" x 72"	50/50	≤0.2
<b>Push Out Awning Windows</b>				
Venting (3440)	-	Class LC-PG40-AP Size Tested 40" x 48"	40/40	≤0.2
Venting (4040)	-	Class LC-PG40-AP Size Tested 48" x 48"	40/40	≤0.2
<b>Double-Hung Full-Frame Windows</b>				
Venting (3470)	-	Class LC-PG55-H Size Tested 40" x 84"	55/55	≤0.2
Venting (3866)	-	Class LC-PG55-H Size Tested 44" x 78"	55/55	≤0.2
Venting (4060)	-	Class LC-PG55-H Size Tested 48" x 72"	55/55	≤0.2
Venting (4686)	-	Class LC-PG30-H Size Tested 54" x 102"	30/30	≤0.2
<b>Double-Hung Picture Full-Frame Windows</b>				
Fixed (5066)	-	Class CW-PG55-FW Size Tested 60" x 78"	55/55	≤0.2
<b>Double-Hung Transom Full-Frame Windows</b>				
Fixed (4040)	-	Class R-PG55-FW Size Tested 48" x 48"	55/55	≤0.2
<b>Double-Hung Insert Windows</b>				
Venting (3866)	-	Class LC-PG30-H Size Tested 44" x 78"	30/30	≤0.2
<b>Double-Hung Picture Insert Windows</b>				
Fixed (5066)	-	Class CW-PG30-FW Size Tested 60" x 78"	30/30	≤0.2
<b>Monumental Single-Hung Windows</b>				
Venting (40100)	-	Class LC-PG35-H Size Tested 48" x 120"	35/35	≤0.2
Venting (5090)	-	Class LC-PG30-H Size Tested 60" x 108"	30/30	≤0.2

\* "Performance Grade (PG)" ratings may vary from tested performance rating for larger or smaller units of a particular type.

*continued on next page*

\* This data is accurate as of October 2018. Due to ongoing product changes, updated test results or new industry standards, this data may change over time.

\* Where designated, Andersen products are certified and labeled to the requirements of the Hallmark Certification Program. Actual performance may vary based on variations in manufacturing, shipping, installation, environmental conditions and conditions of use.

\* Contact your Andersen supplier for more information.

\* Test specimen size is smaller than the North American Fenestration Standard (NAFS) gateway size specified for this product type and performance class.

**Performance Grade & Air Infiltration Ratings for E-Series Windows & Patio Doors – Dual-Pane & Triple-Pane Glass** *(continued)*

For current performance information, please visit [andersenwindows.com](http://andersenwindows.com).

Andersen® Product	Panel Type	AAMA/WDMA/CSA 101/I.S.2/A440 Performance Grade (PG)	+/- Corresponding Design Pressure (DP)	Air Infiltration CFM/FT <sup>2</sup>
<b>Gliding Windows</b>				
Venting, active-stationary (6040)	-	Class CW-PG30-HS Size Tested 72" x 48"	30/30	≤0.2
Venting, active-stationary (6050)	-	Class CW-PG30-HS Size Tested 72" x 60"	30/30	≤0.2
<b>Specialty Windows</b>				
Fixed, rectangle (46120)	-	Class CW-PG55-FW Size Tested 54" x 144" *	55/55	≤0.2
Fixed, rectangle (5080)	-	Class CW-PG75-FW Size Tested 60" x 96"	75/75	≤0.2
<b>Gliding &amp; French Gliding Patio Doors</b>				
Single, stationary (4080)	Contemporary panel with 2 3/4" stiles & rails <sup>1</sup>	Class LC-PG50-SLT Size Tested 50" x 96"	50/50	≤0.2
Two-panel (6080)	Contemporary panels with 4 11/16" stiles & rails <sup>2</sup>	Class LC-PG50-SD Size Tested 71" x 96"	50/50	≤0.2
Two-panel (8080)	Contemporary panels with 4 11/16" stiles & rails <sup>2</sup>	Class LC-PG40-SD Size Tested 95" x 96"	40/40	≤0.2
Two-panel (8080)	Contemporary panels with 2 3/4" stiles & rails	Class LC-PG30-SD Size Tested 95" x 96"	30/30	≤0.2
Four-panel (12080)	Contemporary panels with 4 11/16" stiles & rails <sup>2</sup>	Class LC-PG40-SD Size Tested 142" x 96"	40/40	≤0.2
Four-panel (16080)	Contemporary panels with 2 3/4" stiles & rails <sup>3</sup>	Class LC-PG25-SD Size Tested 190" x 96"	25/25	≤0.2
<b>Hinged Inswing Patio Doors &amp; Sidelights</b>				
Single, stationary or sidelight (34100)	French panel with 2 3/4" stiles, 4 11/16" top rail & 8" bottom rail <sup>4</sup>	Class LC-PG45-FD Size Tested 40" x 119.5"	45/60	≤0.2
Single, stationary (34100)	Contemporary panel with 3 11/16" stiles & rails <sup>5</sup>	Class LC-PG45-FD Size Tested 40.5" x 120"	45/50	≤0.2
Single, active (3486)	Contemporary panel with 4 11/16" stiles & rails <sup>6</sup>	Class LC-PG45-SHD Size Tested 40" x 102"	45/65	≤0.2
Single, active (3486)	Contemporary panel with 3 11/16" stiles & rails	Class LC-PG45-SHD Size Tested 40.5" x 102"	45/50	≤0.2
Single, active, low threshold sill ** (3486)	Contemporary panel with 3 11/16" stiles & rails <sup>5</sup>	Class LC-PG50-LW SHD Size Tested 40.5" x 101.18"	50/50	≤0.2
Single, active, low threshold sill ** (3486)	French panel with 4 11/16" stiles, 4 11/16" top rail & 8" bottom rail <sup>7</sup>	Class LC-PG50-LW SHD Size Tested 40" x 101"	50/60	≤0.2
Single, active (34100)	French panel with 4 11/16" stiles, 4 11/16" top rail & 8" bottom rail <sup>8</sup>	Class LC-PG45-SHD Size Tested 40" x 119.5"	45/65	≤0.2
Single, active (34100)	Contemporary panel with 3 11/16" stiles & rails <sup>5</sup>	Class LC-PG45-SHD Size Tested 40.5" x 120"	45/50	≤0.2
Two-panel, stationary-stationary (6780)	French panels with 4 11/16" stiles, 4 11/16" top rail & 8" bottom rail <sup>7</sup>	Class LC-PG40-FD Size Tested 79" x 96"	40/40	≤0.2
Two-panel, stationary-stationary (6780)	Contemporary panels with 3 11/16" stiles & rails <sup>5</sup>	Class LC-PG40-FD Size Tested 79" x 95.3"	40/40	≤0.2
Two-panel, active-stationary, jamb hinged (6780)	Contemporary panels with 4 11/16" stiles & rails <sup>6</sup>	Class LC-PG45-SHD Size Tested 79" x 96"	45/45	≤0.2
Two-panel, active-stationary, jamb hinged (6780)	Contemporary panels with 3 11/16" stiles & rails	Class LC-PG45-SHD Size Tested 79" x 96"	45/45	≤0.2
Two-panel, active-stationary, astragal hinged (6780)	Contemporary panels with 4 11/16" stiles & rails <sup>6</sup>	Class LC-PG45-SHD Size Tested 79" x 96"	45/45	≤0.2
Two-panel, active-stationary, astragal hinged (6780)	Contemporary panels with 3 11/16" stiles & rails	Class LC-PG45-SHD Size Tested 79" x 96"	45/45	≤0.2
Two-panel, active-passive (6780)	Contemporary panels with 4 11/16" stiles & rails <sup>6</sup>	Class LC-PG40-SHD Size Tested 79" x 96"	40/40	≤0.2
Two-panel, active-passive, low threshold sill ** (6786)	Contemporary panels with 3 11/16" stiles & rails <sup>5</sup>	Class LC-PG30-LW SHD Size Tested 79" x 101"	30/30	≤0.2
Two-panel, active-passive (6786)	Contemporary panels with 4 11/16" stiles & rails <sup>9</sup>	Class LC-PG30-SHD Size Tested 79" x 102"	30/30	≤0.2
Two-panel, active-passive (6786)	Contemporary panels with 3 11/16" stiles & rails	Class LC-PG30-SHD Size Tested 79" x 101.8"	30/40	≤0.2
Two-panel, active-passive, low threshold sill ** (6786)	French panels with 4 11/16" stiles, 4 11/16" top rail & 8" bottom rail <sup>7</sup>	Class LC-PG30-LW SHD Size Tested 79" x 101"	30/30	≤0.2
Two-panel, active-passive (67100)	French panels with 4 11/16" stiles, 4 11/16" top rail & 8" bottom rail <sup>8</sup>	Class LC-PG35-SHD Size Tested 79" x 120"	35/35	≤0.2
Two-panel, active-passive (67100)	Contemporary panels with 3 11/16" stiles & rails <sup>5</sup>	Class LC-PG30-SHD Size Tested 79" x 120"	30/40	≤0.2

\*Performance Grade (PG) ratings may vary from tested performance rating for larger or smaller units of a particular type. *continued on next page*  
 \*This data is accurate as of October 2018. Due to ongoing product changes, updated test results or new industry standards, this data may change over time.  
 \*Where designated, Andersen products are certified and labeled to the requirements of the Hallmark Certification Program. Actual performance may vary based on variations in manufacturing, shipping, installation, environmental conditions and conditions of use.  
 \*Contact your Andersen supplier for more information.  
 \*Test specimen size is smaller than the North American Fenestration Standard (NAFS) gateway size specified for this product type and performance class.  
 \*\*Hinged doors with a low threshold sill have limited water performance.

**Numbered footnotes provide additional panel types for the same patio door, sidelight or transom listed above that are covered by the given test data. Commercial patio door panels, referenced as an additional panel type in the numbered footnotes below, do not include commercial doors with Concealed Panic System (CPS).**

- 1** Applies to similar contemporary door panel with 4 11/16" stiles & rails. Also applies to French door panel with 4 11/16" stiles, 4 11/16" top rail and 8" or 12" bottom rail.
- 2** Also applies to French door panels with 4 11/16" stiles, 4 11/16" top rail and 8" or 12" bottom rail.
- 3** Applies to similar contemporary door panels with 4 11/16" stiles & rails in doors with a unit dimension greater than 12' wide. Also applies to French door panels with 4 11/16" stiles, 4 11/16" top rail and 8" or 12" bottom rail in doors with a unit dimension greater than 12' wide.
- 4** Applies to similar French sidelight panel with 12" bottom rail; includes comparable commercial panel and similar non-commercial panel with intermediate rail and raised panel insert. Also applies to French door panel with 4 11/16" stiles, 4 11/16" top rail and 8" or 12" bottom rail; includes comparable commercial panel and similar non-commercial panel with intermediate rail and raised panel insert.
- 5** Also applies to contemporary door panel(s) with 4 11/16" stiles & rails.
- 6** Also applies to French door panel(s) with 4 11/16" stiles, 4 11/16" top rail and 8" or 12" bottom rail with or without intermediate rail and with or without raised panel insert; includes comparable commercial panel(s).
- 7** Applies to similar French door panel(s) with 12" bottom rail with or without intermediate rail and with or without raised panel insert; includes comparable commercial panel(s).
- 8** Applies to similar French door panel(s) with 12" bottom rail; includes comparable commercial panel(s).
- 9** Also applies to French door panels with 4 11/16" stiles, 4 11/16" top rail and 8" or 12" bottom rail; includes comparable commercial panels.

## Performance Grade & Air Infiltration Ratings for E-Series Windows & Patio Doors – Dual-Pane & Triple-Pane Glass *(continued)*

For current performance information, please visit [andersenwindows.com](http://andersenwindows.com).

Andersen® Product	Panel Type	AAMA/WDMA/CSA 101/I.S.2/A440 Performance Grade (PG)	+/- Corresponding Design Pressure (DP)	Air Infiltration CFM/FT <sup>2</sup>
<b>Hinged Inswing Patio Door Venting Sidelights</b>				
Sidelight, venting (2080)	French panel with 2 3/4" stiles, 4 11/16" top rail & 8" bottom rail <b>10</b>	Class CW-PG45-SLT Size Tested 24" x 96"	45/50	≤0.2
<b>Hinged Inswing Patio Door Transoms</b>				
Fixed (6720)	Panel with 2 3/4" stiles & rails <b>11</b>	Class CW-PG60-TR Size Tested 79" x 24"	60/60	≤0.2
<b>Arch Hinged Inswing Patio Doors &amp; Sidelights</b>				
Single, stationary or sidelight (3480)	French arch panel with 4 11/16" stiles, 4 11/16" top rail & 8" bottom rail <b>12</b>	Class CW-PG45-FD Size Tested 40" x 96"	45/60	≤0.2
Single, active (3480)	French arch panel with 4 11/16" stiles, 4 11/16" top rail & 8" bottom rail <b>13</b>	Class CW-PG45-SHD Size Tested 40" x 96"	45/55	≤0.2
Two-panel, active-passive (6080)	French unequal leg arch panels with 4 11/16" stiles, 4 11/16" top rail & 8" bottom rail <b>13</b>	Class LC-PG40-SHD Size Tested 72" x 96"	40/40	≤0.2
<b>Hinged Outswing Patio Doors &amp; Sidelights</b>				
Single, stationary or sidelight (2080)	French panel with 2 3/4" stiles, 4 11/16" top rail & 8" bottom rail, with intermediate rail at 35" location <b>10</b>	Class CW-PG80-SLT Size Tested 24.5" x 95.3"	80/80	≤0.2
Single, stationary or sidelight (21080)	French panel with 2 3/4" stiles, 4 11/16" top rail & 8" bottom rail, with intermediate rail at 35" location & raised panel insert <b>14</b>	Class CW-PG75-SLT Size Tested 34.6" x 95.3"	75/75	≤0.2
Single, stationary or sidelight (34100)	French panel with 2 3/4" stiles, 4 11/16" top rail & 8" bottom rail <b>15</b>	Class LC-PG75-SLT Size Tested 40" x 119.3"	75/80	≤0.2
Single, stationary (34100)	Contemporary panel with 3 11/16" stiles & rails <b>5</b>	Class LC-PG50-SLT Size Tested 40.5" x 120"	50/50	≤0.2
Single, active (3080)	French panel with 4 11/16" stiles, 4 11/16" top rail & 8" bottom rail, with intermediate rail at 35" location & raised panel insert	Class LC-PG60-SHD Size Tested 36.5" x 95.3"	60/60	≤0.2
Single, active (3080)	French panel with 2 3/4" stiles, 4 11/16" top rail & 8" bottom rail, with intermediate rail at 23 3/4" location & raised panel insert	Class LC-PG60-SHD Size Tested 36.5" x 95.3"	60/60	≤0.2
Single, active (3480)	French panel with 4 11/16" stiles, 4 11/16" top rail & 8" bottom rail <b>8</b>	Class LC-PG60 SHD Size Tested 40" x 95"	60/60	≤0.2
Single, active (3480)	French panel with 4 11/16" stiles, 4 11/16" top rail & 8" bottom rail, with intermediate rail at 35" location <b>16</b>	Class LC-PG60-SHD Size Tested 40" x 95.3"	60/60	≤0.2
Single, active, low threshold sill** (3480)	French panel with 4 11/16" stiles, 4 11/16" top rail & 8" bottom rail <b>7</b>	Class LC-PG60-LW SHD Size Tested 40" x 94"	60/60	≤0.2
Single, active, low threshold sill** (3480)	Contemporary panel with 3 11/16" stiles & rails <b>5</b>	Class LC-PG50-LW SHD Size Tested 40.5" x 94.8"	50/50	≤0.2
Single, active (3486)	Contemporary panel with 4 11/16" stiles & rails	Class LC-PG50-SHD Size Tested 40" x 101"	50/50	≤0.2
Single, active (3486)	Contemporary panel with 3 11/16" stiles & rails	Class LC-PG45-SHD Size Tested 40.5" x 101.5"	50/50	≤0.2
Single, active (34100)	French panel with 4 11/16" stiles, 4 11/16" top rail & 8" bottom rail <b>8</b>	Class LC-PG50-SHD Size Tested 40" x 119.3"	50/50	≤0.2
Single, active (34100)	Contemporary panel with 3 11/16" stiles & rails <b>5</b>	Class LC-PG45-SHD Size Tested 40.5" x 119.3"	50/50	≤0.2
Two-panel, stationary-stationary (6780)	French panels with 4 11/16" stiles, 4 11/16" top rail & 8" bottom rail <b>7</b>	Class LC-PG60-FD Size Tested 79" x 95.3"	60/60	≤0.2
Two-panel, stationary-stationary (6780)	Contemporary panels with 3 11/16" stiles & rails <b>5</b>	Class LC-PG50-FD Size Tested 79" x 96"	50/50	≤0.2

\*Performance Grade (PG) ratings may vary from tested performance rating for larger or smaller units of a particular type.

*continued on next page*

\*This data is accurate as of October 2018. Due to ongoing product changes, updated test results or new industry standards, this data may change over time.

\*Where designated, Andersen products are certified and labeled to the requirements of the Hallmark Certification Program. Actual performance may vary based on variations in manufacturing, shipping, installation, environmental conditions and conditions of use.

\*Contact your Andersen supplier for more information.

\*\*Hinged doors with a low threshold sill have limited water performance.

**Numbered footnotes provide additional panel types for the same patio door, sidelight or transom listed above that are covered by the given test data.**

**Commercial patio door panels, referenced as an additional panel type in the numbered footnotes below, do not include commercial doors with Concealed Panic System (CPS).**

**5** Also applies to contemporary door panel(s) with 4 11/16" stiles & rails.

**7** Applies to similar French door panel(s) with 12" bottom rail with or without intermediate rail and with or without raised panel insert; includes comparable commercial panel(s).

**8** Applies to similar French door panel(s) with 12" bottom rail; includes comparable commercial panel(s).

**10** Also applies to all available panels.

**11** Also applies to transom panel with 4 11/16" stiles and 2 3/4" rails and transom panel with 4 11/16" stiles and rails; includes all commercial transom panels.

**12** Applies to similar French door panel with 12" bottom rail; includes arch and unequal leg arch door panel with or without intermediate rail and with or without raised panel insert. Also applies to French sidelight panel with 8" or 12" bottom rail with or without intermediate rail and with or without raised panel insert.

**13** Also applies to all arch and unequal leg arch door panels with 4 11/16" stiles.

**14** Applies to similar French sidelight panel with intermediate rail at 23 3/4" location and raised panel insert. Also applies to French door panel with 4 11/16" stiles, 4 11/16" top rail and 8" or 12" bottom rail with intermediate rail with raised panel insert.

**15** Applies to similar French sidelight panel with 12" bottom rail; includes comparable commercial sidelight panel. Also applies to French door panel with 4 11/16" stiles, 4 11/16" top rail and 8" or 12" bottom rail; includes comparable commercial door panel.

**16** Applies to similar French door panel with intermediate rail at 23 3/4" location. Also applies to French door panel with 4 11/16" stiles, 4 11/16" top rail and 12" bottom rail and intermediate rail; includes comparable commercial door panel.

**Performance Grade & Air Infiltration Ratings for E-Series Windows & Patio Doors – Dual-Pane & Triple-Pane Glass** *(continued)*

For current performance information, please visit [andersenwindows.com](http://andersenwindows.com).

Andersen® Product	Panel Type	AAMA/WDMA/CSA 101/I.S.2/A440 Performance Grade (PG)	+/- Corresponding Design Pressure (DP)	Air Infiltration CFM/FT <sup>2</sup>
<b>Hinged Outswing Patio Doors &amp; Sidelights</b>				
Two-panel, active-passive (6780)	French panels with 4 11/16" stiles, 4 11/16" top rail & 8" bottom rail <b>7</b>	Class LC-PG60-SHD Size Tested 79" x 95"	60/60	≤0.2
Two-panel, active-passive, low threshold sill ** (6780)	French panels with 4 11/16" stiles, 4 11/16" top rail & 8" bottom rail <b>17</b>	Class LC-PG50-LW SHD Size Tested 79" x 94"	50/50	≤0.2
Two-panel, active-passive, low threshold sill ** (6780)	Contemporary panels with 3 11/16" stiles & rails <b>5</b>	Class LC-PG40-LW SHD Size Tested 79" x 95"	40/40	≤0.2
Two-panel, active-passive (6786)	Contemporary panels with 4 11/16" stiles & rails	Class LC-PG40-SHD Size Tested 79" x 101"	40/40	≤0.2
Two-panel, active-passive (6786)	Contemporary panels with 3 11/16" stiles & rails	Class LC-PG45-SHD Size Tested 79" x 101.5"	45/45	≤0.2
Two-panel, active-passive (67100)	French panels with 4 11/16" stiles, 4 11/16" top rail & 8" bottom rail <b>8</b>	Class LC-PG40-SHD Size Tested 79" x 119"	40/40	≤0.2
Two-panel, active-passive (67100)	Contemporary panels with 3 11/16" stiles & rails <b>5</b>	Class LC-PG30-SHD Size Tested 79" x 120"	30/40	≤0.2
<b>Hinged Outswing Patio Door Venting Sidelights</b>				
Sidelight, venting (2080)	French panel with 2 3/4" stiles, 4 11/16" top rail & 8" bottom rail with intermediate rail at 35" location <b>10</b>	Class CW-PG50 Size Tested 24" x 96"	50/50	≤0.2
<b>Hinged Outswing Patio Door Transoms</b>				
Fixed (6720)	Panel with 2 3/4" stiles, top rail & bottom rail <b>10</b>	Class CW-PG80-TR Size Tested 79" x 24"	80/80	≤0.2
<b>Arch Hinged Outswing Patio Doors &amp; Sidelights</b>				
Single, stationary or sidelight (3480)	French arch panel with 4 11/16" stiles, 4 11/16" top rail & 8" bottom rail <b>12</b>	Class CW-PG80-FD Size Tested 40" x 96"	80/80	≤0.2
Single, active (3480)	French arch panel with 4 11/16" stiles, 4 11/16" top rail & 8" bottom rail <b>13</b>	Class LC-PG60-SHD Size Tested 40" x 96"	60/60	≤0.2
Two-panel (6080)	French unequal leg arch panels with 4 11/16" stiles, 4 11/16" top rail & 8" bottom rail <b>13</b>	Class LC-PG60-SHD Size Tested 79" x 96"	60/60	≤0.2

\*Performance Grade (PG) ratings may vary from tested performance rating for larger or smaller units of a particular type.

\*This data is accurate as of October 2018. Due to ongoing product changes, updated test results or new industry standards, this data may change over time.

\*Where designated, Andersen products are certified and labeled to the requirements of the Hallmark Certification Program. Actual performance may vary based on variations in manufacturing, shipping, installation, environmental conditions and conditions of use.

\*Contact your Andersen supplier for more information.

\*\*Hinged doors with a low threshold sill have limited water performance.

**Numbered footnotes provide a list of additional panel types for the same patio door, sidelight or transom listed above that are covered by the given test data.**

**Commercial patio door panels, referenced as an additional panel type in the numbered footnotes below, do not include commercial doors with Concealed Panic System (CPS).**

**5** Also applies to contemporary door panel(s) with 4 11/16" stiles & rails.

**7** Applies to similar French door panel(s) with 12" bottom rail with or without intermediate rail and with or without raised panel insert; includes comparable commercial panel(s).

**8** Applies to similar French door panel(s) with 12" bottom rail; includes comparable commercial panel(s).

**10** Also applies to all available panels.

**12** Applies to similar French door panel with 12" bottom rail; includes arch and unequal leg arch door panel with or without intermediate rail and with or without raised panel insert. Also applies to French sidelight panel with 8" or 12" bottom rails with or without intermediate rail and with or without raised panel insert.

**13** Also applies to all arch and unequal leg arch door panels with 4 11/16" stiles.

**17** Applies to similar French door panel with 12" bottom rail; includes comparable commercial panel. Also applies to French door panel with 4 11/16" stiles, 4 11/16" top rail and 8" or 12" bottom rail with intermediate rail and raised panel insert.

For performance ratings for E-Series products with Stormwatch® Protection, go to [andersenwindows.com](http://andersenwindows.com).

## Sound Transmission Ratings for E-Series Windows & Patio Doors

For current performance information, please visit [andersenwindows.com](http://andersenwindows.com).

Andersen® Product & Glass Type	Panel Type	Test Size	Sound Transmission Class (STC)	Outdoor/Indoor Transmission Class (OITC)
<b>Casement Windows - Stationary</b>				
Dual-Pane	-	48" x 60"	29	25
Dual-Pane Laminated, 0.030"			33	29
STC Upgrade			32	29
<b>Casement Windows - Venting</b>				
Dual-Pane	-	24" x 80"	29	25
Triple-Pane			30	24
Dual-Pane Laminated, 0.030"			33	29
STC Upgrade			33	28
<b>Double-Hung Windows</b>				
Dual-Pane	-	48" x 60"	28	24
Triple-Pane			28	24
Dual-Pane Laminated, 0.030"			33	29
STC Upgrade			32	27
<b>Double-Hung Picture Windows</b>				
Dual-Pane	-	48" x 60"	31	26
Dual-Pane Laminated, 0.030"			35	30
STC Upgrade			34	30
<b>Specialty Windows</b>				
Dual-Pane	-	48" x 60"	28	24
Dual-Pane Laminated, 0.030"			31	25
STC Upgrade			34	29
<b>French Gliding Patio Doors</b>				
Dual-Pane	French panels with 4 11/16" stiles, 4 11/16" top rail & 8" bottom rail	72" x 80"	29	24
Triple-Pane			30	25
Dual-Pane Laminated, 0.030"			32	29
STC Upgrade			30	28
<b>Hinged Inswing Patio Doors - Single Panel</b>				
Dual-Pane	French panel with 4 11/16" stiles, 4 11/16" top rail & 12" bottom rail	37.875" x 84"	31	26
Triple-Pane			31	27
Dual-Pane Laminated, 0.030"			33	30
STC Upgrade			33	30
<b>Hinged Inswing Patio Doors - Two-Panel</b>				
Dual-Pane	French panels with 4 11/16" stiles, 4 11/16" top rail & 12" bottom rail	74.812" x 84"	30	26
Triple-Pane			31	26
Dual-Pane Laminated, 0.030"			33	30
STC Upgrade			32	29
<b>Hinged Outswing Patio Doors - Single Panel</b>				
Dual-Pane	French panel with 4 11/16" stiles, 4 11/16" top rail & 12" bottom rail	37.875" x 84"	30	26
Triple-Pane			31	26
Dual-Pane Laminated, 0.030"			33	30
STC Upgrade			33	30
<b>Hinged Outswing Patio Doors - Two-Panel</b>				
Dual-Pane	French panels with 4 11/16" stiles, 4 11/16" top rail & 12" bottom rail	74.812" x 84"	29	25
Triple-Pane			30	26
Dual-Pane Laminated, 0.030"			33	30
STC Upgrade			32	29

- "Sound Transmission Class (STC)" & "Outdoor/Indoor Transmission Class (OITC)" ratings are for individual units based on independent tests and represent entire unit.
- This data is accurate as of October 2018. Due to ongoing product changes, updated test results or new industry standards, this data may change over time.
- Contact your Andersen supplier for more information.

**Notes**

A large grid of graph paper, consisting of 30 columns and 40 rows of small squares, intended for taking notes.

# Notes

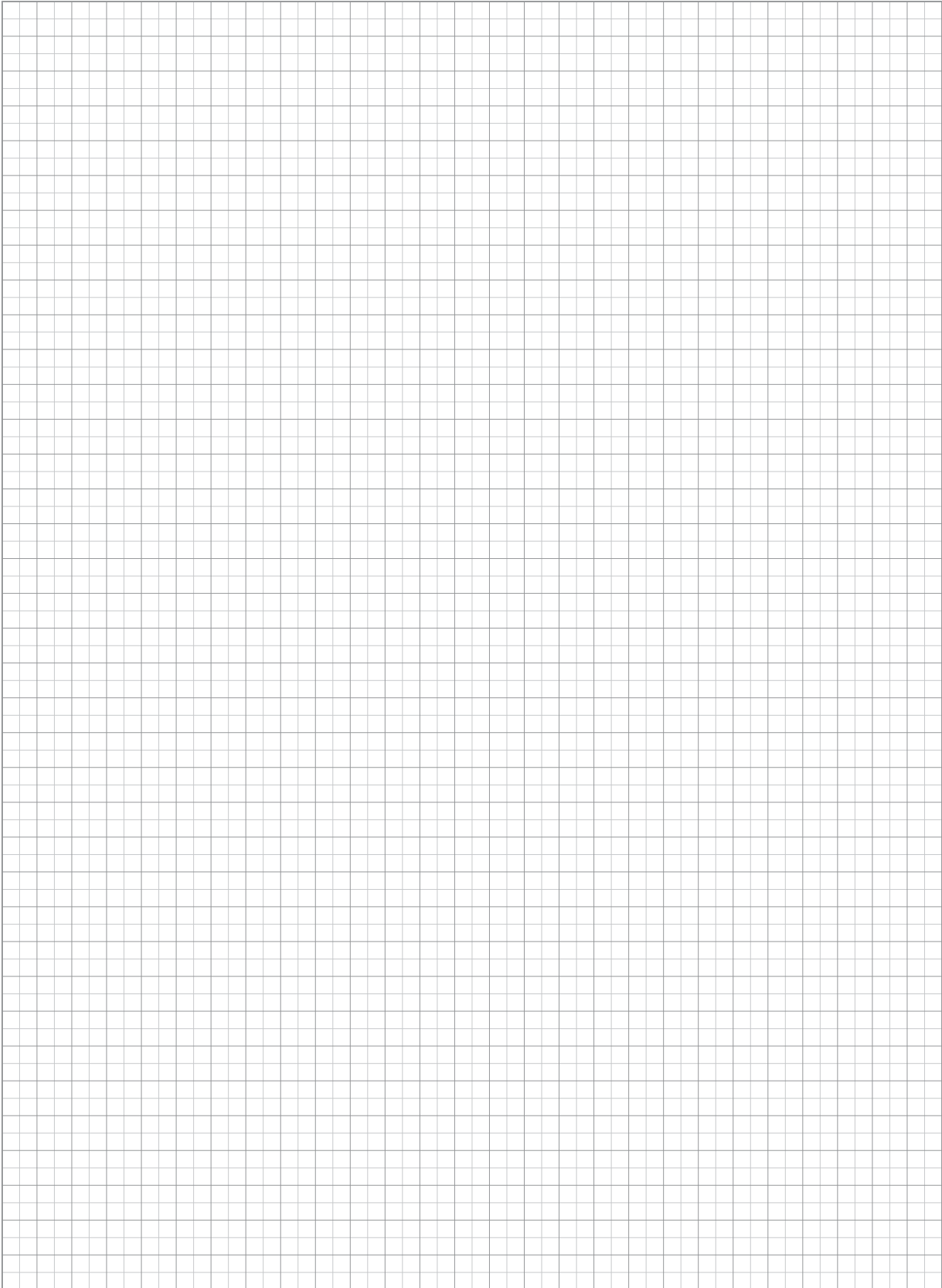



142 E-Series  
Gliding Patio Doors

106 E-Series  
Hinged Patio Doors

98 E-Series  
Specialty Windows

92 E-Series  
Gliding Windows

80 E-Series  
Bay & Bow Windows

56 E-Series  
Double-Hung Windows

48 E-Series  
Awning Windows

32 E-Series  
Casement Windows

154 Installation Materials &  
Product Performance



"Andersen" and all other marks where denoted are trademarks of Andersen Corporation.  
©2019 Andersen Corporation. All rights reserved. 09/19 Part #9067500



## PDF NAVIGATION TIPS

Welcome to an overview of the enhanced navigation tools available in this PDF. Here are some simple tips on PDF navigation. Before you begin be sure you are using the latest version of Adobe Acrobat Reader DC, available at – <https://get.adobe.com/reader/>

To watch a 3-minute tutorial on navigating catalog PDFs, go to: <https://youtu.be/sWWnYn6ON3Y>

### BOOKMARK NAVIGATION

①

Acrobat will display the bookmarks panel when you open the PDF.

**Bookmarks** are the easiest way to find specific product information.

Select a topic and that page will be displayed.

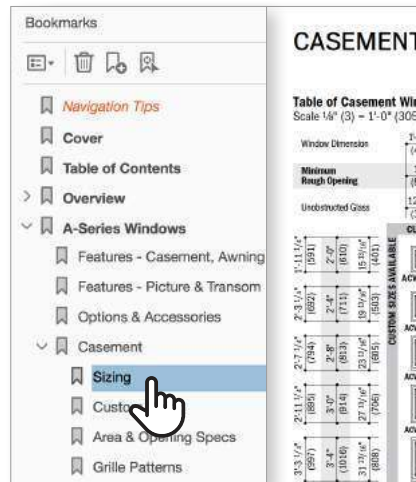

②

If you need to print a specific section, **right click on that section** within in the bookmarks panel and choose “**Print Section.**”

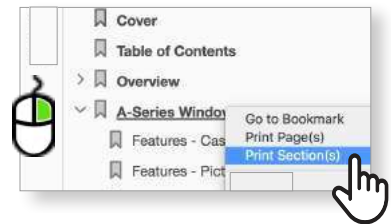

### LINKS AND URL NAVIGATION

①

You can also use the **embedded links** to navigate between sections. All links are underlined in blue.

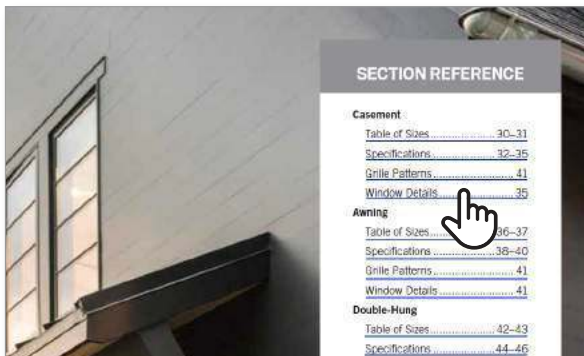

②

Website links automatically open in your web browser.



Add additional navigation tools by adjusting the default settings in Acrobat.

## TOOL BAR NAVIGATION

1

To add a **“Jump Back” Button** to your tool bar, **right click on tool bar**, select **Show Page Navigation Tools** and choose **Show All Page Navigation Tools**.

Right and left facing arrows are added to the tool bar allowing you to go back or forward to the last page you viewed.

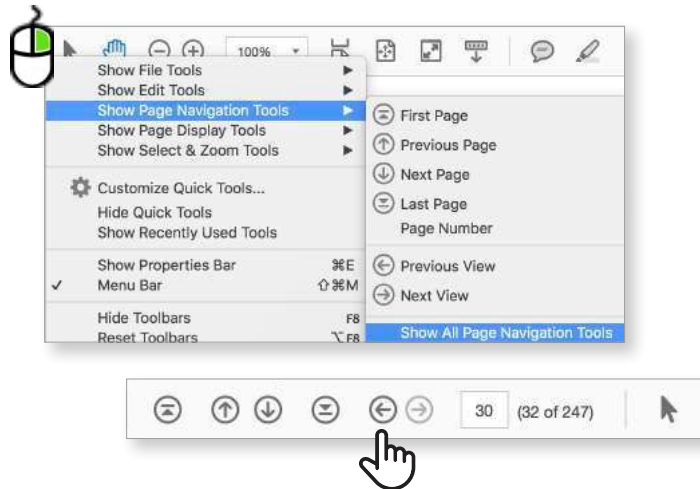

2

Another helpful tool is the **Loupe Tool**. It allows you to zoom in on the page without having to increase the page size.

To add a **Loupe Tool** to your tool bar, **right click on tool bar**, select **Show Select & Zoom Tools** and then choose **Show All Select & Zoom Tools**.

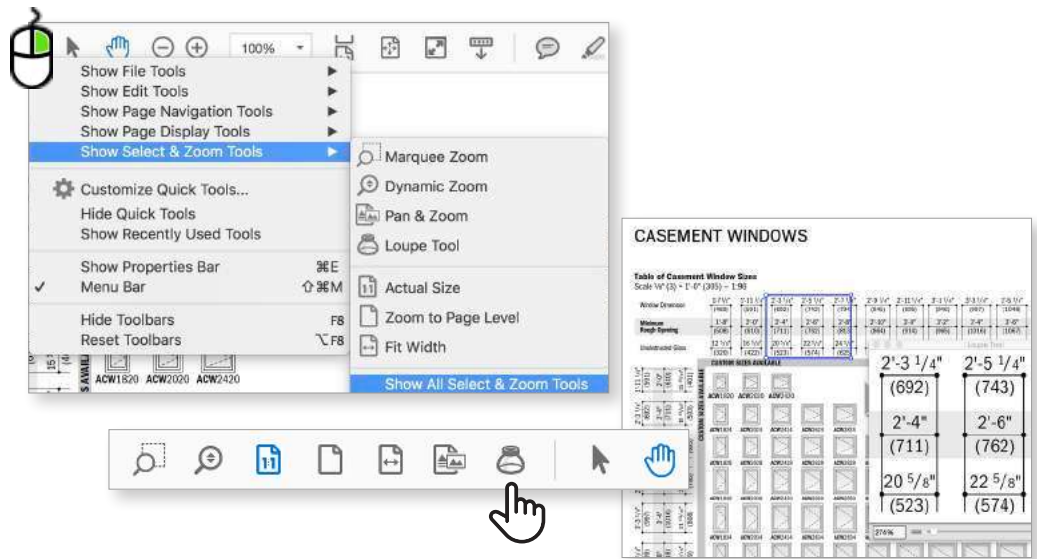

3

You can also use the **commenting tools**. Add a post-it-note with your comments or highlight important information.

Be sure to save the file.



To watch a 3-minute tutorial on navigating catalog PDFs, go to: <https://youtu.be/sWWnYn60N3Y>

We are always looking for ways to improve.  
Please send feedback to [webmarketing@andersencorp.com](mailto:webmarketing@andersencorp.com).