

# **400 SERIES**

---

## **WINDOWS & DOORS**



**THE WINDOW CONTRACTORS  
TRUST THE MOST\***

\* 2018 Contractor Survey of Andersen 400 Series windows.

# CONTENTS

## 400 SERIES WINDOWS & PATIO DOORS

Performance & Replacement Solutions . . . . .	2-3
Home Styles & Product Overview . . . . .	4-5
Exterior & Interior Options . . . . .	6
Exterior Trim System . . . . .	7
Window Hardware . . . . .	8
Patio Door Hardware . . . . .	10
Glass & Grille Options . . . . .	12-13
Insect Screen Options & Smart Home Solutions . . . . .	14-15
Comparison Chart . . . . .	17
<hr/>	
Casement & Awning Windows . . . . .	19
Replacement Casement & Awning Windows . . . . .	37
Complementary Casement Windows . . . . .	41
Woodwright® Double-Hung Full-Frame Windows . . . . .	47
Woodwright Double-Hung Insert Windows . . . . .	67
Tilt-Wash Double-Hung Full-Frame Windows . . . . .	75
Narroline® Conversion Kit . . . . .	87
Tilt-Wash Double-Hung Insert Windows . . . . .	89
Bay & Bow Windows . . . . .	97
Gliding Windows . . . . .	111
Specialty Windows . . . . .	117
Complementary Specialty Windows . . . . .	137
Frenchwood® Gliding Patio Doors . . . . .	141
Frenchwood Hinged Inswing Patio Doors . . . . .	149
Frenchwood Patio Door Sidelights & Transoms . . . . .	159
Complementary Curved Top Patio Doors . . . . .	163
<hr/>	
Art Glass . . . . .	173
Exterior Trim . . . . .	175
<hr/>	
Combination Designs . . . . .	181
Product Performance . . . . .	194
Sustainability . . . . .	208
Installation . . . . .	210

For warranty information, visit [andersenwindows.com/warranty](http://andersenwindows.com/warranty).



**The MOST RECOGNIZED, TRUSTED  
and RECOMMENDED  
brand of windows and patio doors.\***



**Hanley Wood Builder Brand Use Study  
1998-2018  
Windows – Wood & Clad-Wood Category**



**Hanley Wood Remodeling Brand Use Study  
2006, 2010, 2013, 2015, 2017  
Windows – Wood & Clad-Wood Category**



**Awarded Most Environmentally Friendly  
Windows 7 years running  
2011-2018**



**Andersen Corporation, including its subsidiaries, has been named a 2019 ENERGY STAR Partner of the Year – Sustained Excellence Award winner, the highest honor given by ENERGY STAR, for continued leadership in protecting the environment through superior energy efficiency achievements.**

\* 2018 U.S. Homeowner Brand Study of Andersen and Renewal by Andersen brands vs. competitive brands.  
“ENERGY STAR” is a registered trademark of the U.S. Environmental Protection Agency.



When you choose Andersen, you not only get the quality, style and performance that we've built our reputation on, but also exceptional service and support. Our exclusive Owner-2-Owner® limited warranties offer homeowners peace of mind, plus real added value.

## 400 SERIES PRODUCTS

### TIME-TESTED, CLASSIC WOOD CRAFTSMANSHIP

As our most popular products, the 400 Series product line brings you the best overall blend of performance and style to satisfy just about any window or patio door need. With fewer callbacks, easy installation and a reputation that withstands the test of time, it's no wonder why 400 Series windows are the clad window of choice for contractors.\*



#### Time-Tested

Our best-selling product line, 400 Series windows and patio doors are durable and stand the test of time.\*\*



#### Easy to Install

400 Series windows and patio doors are designed for easy installation.



#### Fewer Callbacks

The window with fewer callbacks according to contractors.\*

With Andersen 400 Series products, have confidence knowing you and your customers will be getting the quality and performance in which Andersen built its reputation, along with extraordinary customer service and support.

**THAT'S WHY CONTRACTORS TRUST THEM IN THEIR OWN HOMES  
MORE THAN ANY OTHER WINDOW.\***

\* 2018 Contractor survey of Andersen 400 Series windows.

\*\* Visit [andersenwindows.com/warranty](http://andersenwindows.com/warranty) for details.

# RELIABLE & ENERGY EFFICIENT

As our most popular and longest-standing products, the 400 Series product line offers a distinct blend of design, reliability and trade confidence. Designed for easy installation for replacement, remodel or new construction projects, 400 Series products feature our Perma-Shield® exterior cladding that revolutionized the window industry. They are also backed by our renowned limited warranty and the largest service network in the industry.

## ENERGY-SAVING GLASS FOR ANY CLIMATE

Andersen makes windows and patio doors with options that make them ENERGY STAR® v. 6.0 certified throughout the United States.

Visit [andersenwindows.com/energystar](http://andersenwindows.com/energystar) for more information and to verify that the product with your glass option is ENERGY STAR certified in your area.



## RIGOROUSLY TESTED

The exclusive Andersen® Perma-Shield system gives our windows and doors a tough, protective shell that safeguards the wood inside. It repels water, resists dents\* and stays beautiful for years.

## OPTIONS FOR THE HARSHTEST WEATHER

400 Series windows with Stormwatch® Protection meet building code requirements in coastal areas. Products with Stormwatch Protection are energy efficient, resist the effects of salt water and stand up to hurricane-force winds and wind-borne debris.\*\* For details, visit [andersenwindows.com/coastal](http://andersenwindows.com/coastal).



## LOW MAINTENANCE, NEVER NEEDS PAINTING

The Perma-Shield exteriors on Andersen 400 Series windows and doors offer superior weather resistance and are virtually maintenance free.

## QUALITY SO SOLID, THE WARRANTY IS TRANSFERABLE\*

Many other window and door warranties end when a home is sold, but our coverage — 20 years on glass, 10 years on non-glass parts — transfers from each owner to the next. And, because it is not prorated, the coverage offers full benefits, year after year, owner after owner. So it can add real value when you decide to sell your home.

## OWNER2OWNER<sup>®</sup> LIMITED WARRANTY

## BUILT FOR YEARS TO COME<sup>®</sup>

Our products are built strong to last long. We use the right materials in the right places, including solid wood, fiberglass and our own Fibrex® composite material. These give our windows and doors superior strength, stability and long-term beauty.

## KEEPS THE WEATHER OUT

Our weather-resistant construction and careful selection of weatherstrip by product type, seals out drafts, wind and water whatever the weather.

\* Visit [andersenwindows.com/warranty](http://andersenwindows.com/warranty) for details.

\*\* Andersen 400 Series casement window, other product performance may vary.

# REPLACEMENT SOLUTIONS

Find the comfort and low maintenance your customers are looking for in replacement windows with Andersen. Our replacement and insert windows are available in custom sizes, designed for easy installation and arrive with an installation kit, so you finish in less time. Andersen® windows and patio doors have beautiful wood interiors that add value to your customers' homes — so they're not just replacing, they're upgrading.



## 400 SERIES WOODWRIGHT® DOUBLE-HUNG INSERT WINDOW

The classic, traditional style of Woodwright full-frame windows in a time-saving insert.



## 400 SERIES TILT-WASH DOUBLE-HUNG INSERT WINDOW

Our best-selling double-hung window in an insert for easy replacement.



## 400 SERIES REPLACEMENT CASEMENT & AWNING WINDOWS

Available without an installation flange for easy window replacement from inside or outside. Features predrilled, through-the-jamb installation holes for quick installation.

Our insert and replacement windows include flat, self-hanging shims, backer rod, installation screws and complete instructions.



## CUSTOM-SIZE PATIO DOORS

Whether you need a hinged or gliding patio door for replacement, Andersen has a number of custom-size options to fit your project.



## CUSTOM-SIZE FULL-FRAME WINDOWS

When the existing window frame is rotted or deteriorated or you're modifying the size or shape of the existing window opening, our full-frame double-hung, casement, awning and specialty windows are available in custom sizes to fit your project.



# HOME STYLES

From contemporary design to traditional and classic architecture, 400 Series products offer a time-tested blend of engineering and craftsmanship, combined with a variety of style options that can elevate a classic wood window into a stunning focal point in any home style. Visit our Home Style Library at [andersenwindows.com/stylelibrary](https://andersenwindows.com/stylelibrary).

## TRADITIONAL



## FARMHOUSE



## MODERN



# PRODUCT OVERVIEW



## DOUBLE-HUNG WINDOWS

Choose Woodwright® double-hung windows that replicate the look of traditional architecture or our best-selling tilt-wash double-hung windows that are extremely energy efficient. Both are available as full-frame or insert windows and can be part of bay or bow window combinations. Coordinating picture and transom windows are also available.



## SPECIALTY WINDOWS

Choose from a collection of stylish shapes to help distinguish a home's style or create a delicate accent.



Woodwright full-frame windows come in a variety of shapes.



Our **Narroline® Conversion Kit** can upgrade Andersen® Narroline double-hung windows to tilt-wash windows.



**Complementary Specialty Windows** offer 35 additional shapes and custom sizes.



## CASEMENT & AWNING WINDOWS

Casement and awning windows are energy efficient and are built with our low-maintenance Perma-Shield® cladding. Available for new construction or replacement, as integral twin or triple units or as part of bay or bow window combinations. Coordinating picture and transom windows are also available.



## GLIDING WINDOWS

Superior energy efficiency, reliable performance and uncommon beauty. Both sash on our gliding windows open for improved ventilation.

**Complementary Casement Windows** come in a variety of shapes and in French casement options.



## FRENCHWOOD® GLIDING & HINGED PATIO DOORS

Wide wood profiles provide the authentic craftsmanship of traditional French doors and our Perma-Shield exterior cladding protects the unit and offers low maintenance. Add blinds-between-the-glass to conveniently control light and privacy. To learn more about other traditional and contemporary style Andersen door options, visit [andersenwindows.com/doors](http://andersenwindows.com/doors).

Frame any Frenchwood patio door with **Frenchwood Patio Door Sidelights and Transoms**.



**Complementary Curved Top Patio Doors**, including Springline™ and arch hinged doors, are handcrafted and complement our 400 Series products.



# EXTERIOR & INTERIOR OPTIONS

## EXTERIOR COLORS

Our Perma-Shield® exterior cladding system, a time-tested Andersen innovation, offers low maintenance and durability while also providing an attractive appearance.



White Canvas Sandtone Terratone Forest Green Dark Bronze Black

## INTERIOR OPTIONS\*

Most 400 Series windows are available in unfinished stain-grade pine or with a long-lasting,\*\* low-maintenance white, dark bronze or black finish. 400 Series Woodwright® windows and Frenchwood® patio doors can also be ordered with unfinished oak or maple interiors.

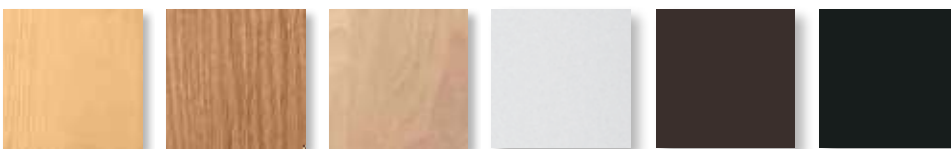

Pine Oak Maple White Dark Bronze†‡ Black†‡

\* Some products are not available in all colors or wood species. See your Andersen supplier for details.

\*\* Visit [andersenwindows.com/warranty](http://andersenwindows.com/warranty) for details.

Printing limitations prevent exact replication of color and finishes. See your Andersen supplier for actual color and finish samples.

† Dark bronze and black interior units have matching exteriors.

‡ Not available on 400 Series Woodwright double-hung windows.

# EXTERIOR TRIM SYSTEM

Add curb appeal with Andersen® exterior trim. Our trim is made with Fibrex® composite material, an environmentally smart composite that contains 40% pre-consumer reclaimed wood fiber by weight. For details, see page 175.

**Time-saving and cost-effective**



**Innovative attachment strip**

**No nail holes, no visible fasteners, no painting**



Sandtone window with cocoa bean trim

**Independent of water management system for easy installation**

**Style that gets noticed**

Our wide trim profiles overlap the window frame to create clean lines without visible sealant joints. Mitered brick mould corners and butt joints on flat casing profiles reflect traditional corner joints.



Visit [andersenwindows.com/exteriortrim](https://andersenwindows.com/exteriortrim) to learn more.

## TRIM COLORS



White

Canvas

Sandtone

Terratone

Dark Bronze

Forest Green

Dove Gray

Prairie Grass

Red Rock

Cocoa Bean

Black

# WINDOW HARDWARE\*

Window hardware enhances the overall design of a window and harmonizes with a home's décor. That's why we offer a broad range of hardware styles and finishes.

## HARDWARE FINISHES

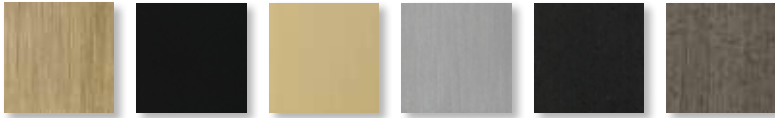

Antique Brass    Black    Bright Brass    Brushed Chrome    Distressed Bronze    Distressed Nickel



Gold Dust    Oil Rubbed Bronze    Polished Chrome    Satin Nickel    Stone    White

\* Hardware is sold separately, except standard hardware. Distressed bronze and oil rubbed bronze are "living" finishes that will change with time and use. Printing limitations prevent exact finish replication. See your Andersen supplier for actual finish samples.



## WOODWRIGHT® DOUBLE-HUNG



**STANDARD**  
Lock & Keeper

Antique Brass | **Black** | Bright Brass  
Brushed Chrome | Distressed Bronze | Distressed Nickel  
Gold Dust | Oil Rubbed Bronze | Polished Chrome  
Satin Nickel | Stone | White

## TILT-WASH DOUBLE-HUNG



**STANDARD**  
Lock & Keeper

Standard: Stone | White  
Optional: Black | **Gold Dust**



**ESTATE™**  
Lock & Keeper

Antique Brass | **Bright Brass** | Brushed Chrome  
Distressed Bronze | Distressed Nickel | Oil Rubbed Bronze  
Polished Chrome | Satin Nickel

Estate lock and keeper is available only for 400 Series tilt-wash double-hung windows.

## DOUBLE-HUNG SASH LIFTS



Bar Lift



Finger Lift



Hand Lift

### TRADITIONAL

Antique Brass | Black | Bright Brass | Brushed Chrome  
Distressed Bronze | Distressed Nickel | Gold Dust | **Oil Rubbed Bronze**  
Polished Chrome | Satin Nickel | Stone | White



Bar Lift



Finger Lift



Hand Lift

### CLASSIC™

Stone | White

Classic double-hung sash lifts are only available for 400 Series Woodwright® double-hung windows.



Bar Lift



Finger Lift



Hand Lift

### CONTEMPORARY

Antique Brass | Black  
Bright Brass | Brushed Chrome  
Distressed Bronze | **Distressed Nickel**  
Gold Dust | Oil Rubbed Bronze  
Polished Chrome | Satin Nickel  
Stone | White

### ESTATE

Antique Brass | **Bright Brass** | Brushed Chrome  
Distressed Bronze | Distressed Nickel  
Oil Rubbed Bronze | Polished Chrome | Satin Nickel

Estate double-hung sash lifts are only available for 400 Series Woodwright double-hung windows.

## GLIDING WINDOW



Antique Brass | Black | Bright Brass | **Brushed Chrome**  
Distressed Bronze | Distressed Nickel | Oil Rubbed Bronze  
Polished Chrome | Satin Nickel | Stone | White

## CASEMENT & AWNING



### CONTEMPORARY FOLDING

Black | Bright Brass | Gold Dust  
Oil Rubbed Bronze | **Satin Nickel**  
Stone | White



### TRADITIONAL FOLDING

Antique Brass | Black | Bright Brass  
**Distressed Bronze** | Distressed Nickel  
Gold Dust | Oil Rubbed Bronze  
Satin Nickel | Stone | White

Folding handles avoid interference with window treatments.



### CLASSIC SERIES

Stone | White



### ESTATE

Antique Brass | **Bright Brass** | Brushed Chrome  
Distressed Bronze | Distressed Nickel  
Oil Rubbed Bronze | Polished Chrome | Satin Nickel

Bold names denote finish shown.

Hardware is sold separately, except standard hardware.

Distressed bronze and oil rubbed bronze are "living" finishes that will change with time and use.

# PATIO DOOR HARDWARE\*



**YUMA®**  
Distressed Bronze  
Distressed Nickel

**ENCINO®**  
Distressed Bronze  
Distressed Nickel

**NEWBURY®**  
Antique Brass | Bright Brass  
Brushed Chrome | **Oil Rubbed Bronze**  
Polished Chrome | Satin Nickel

**ANVERS®**  
Bright Brass | Oil Rubbed Bronze  
**Satin Nickel**

## HARDWARE FINISHES

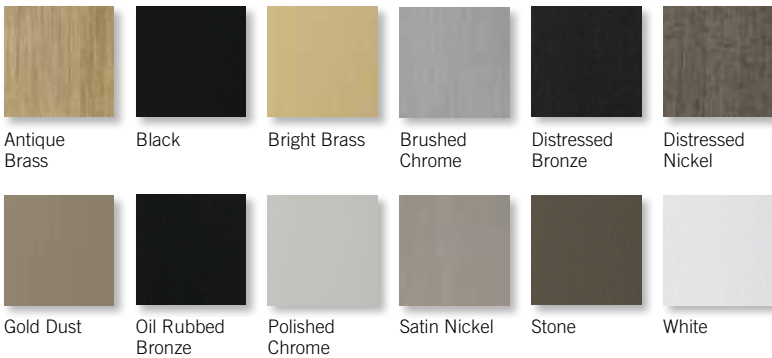

\* Hardware sold separately.  
Matching hinges available for inswing patio doors.  
Distressed bronze and oil rubbed bronze are "living" finishes that will change with time and use.  
Bright brass and satin nickel finishes on patio door hardware feature a 10-year limited warranty.  
Printing limitations prevent exact finish replication. See your Andersen supplier for actual finish samples.

With Andersen, you have a wider selection of hardware styles and finishes than you'll find with just about any other manufacturer. We offer six distinctively different hardware styles — Yuma,<sup>®</sup> Encino,<sup>®</sup> Newbury,<sup>®</sup> Anvers,<sup>®</sup> Covington™ and Whitmore<sup>®</sup> — in solid forged brass with eight metal finish options. And we offer two hardware styles — Albany and Tribeca<sup>®</sup> — in zinc die cast with durable powder-coated finishes. Also, look for additional hardware options such as exterior keyed locks and matching hinge finishes in the detailed product sections for each individual patio door.



**COVINGTON™**

Antique Brass | **Bright Brass**  
Oil Rubbed Bronze



**WHITMORE<sup>®</sup>**

Antique Brass | Bright Brass  
Oil Rubbed Bronze | Satin Nickel



**ALBANY**

Black | **Gold Dust**  
Stone | White



**TRIBECA<sup>®</sup>**

Stone | **White**

**FSB<sup>®</sup> HINGED PATIO DOOR HARDWARE\***

Durable, stainless steel FSB hinged door hardware features clean lines and a sleek satin finish for a thoroughly modern look. Choose from four handle styles.



Satin Stainless Steel



1035



1075



1076



1102

\* Hardware sold separately.  
"FSB" is a registered trademark of Franz Schneider Brakel GmbH & Co.

# GLASS OPTIONS

Andersen has the glass you need to get the performance you want. From SmartSun™ glass with HeatLock® coating that is ENERGY STAR® certified in all climate zones\* to PassiveSun® glass that helps heat homes in northern areas, there's an option for every climate, project and customer. Check with your supplier for the selections that meet ENERGY STAR requirements in your area.

## PERFORMANCE COMPARISON OF ANDERSEN® GLASS OPTIONS

GLASS	ENERGY		LIGHT	
	U-FACTOR	SOLAR HEAT GAIN COEFFICIENT	VISIBLE LIGHT TRANSMITTANCE	UV PROTECTION
	How well a product prevents heat from escaping.	How well a product blocks heat caused by sunlight.	How much visible light comes through a product.	How well a product blocks ultraviolet rays.
SmartSun	● ● ● ○	● ● ● ●	● ● ● ○	● ● ● ●
SmartSun with HeatLock Coating	● ● ● ●	● ● ● ●	● ● ○ ○	● ● ● ●
Low-E4®	● ● ● ○	● ● ● ○	● ● ● ○	● ● ● ○
Low-E4 with HeatLock Coating	● ● ● ●	● ● ● ○	● ● ● ○	● ● ● ○
Sun	● ● ● ○	● ● ● ●	● ○ ○ ○	● ● ● ○
PassiveSun	● ● ● ○	● ○ ○ ○	● ● ● ○	● ● ● ○
PassiveSun with HeatLock Coating	● ● ● ○	● ○ ○ ○	● ● ● ○	● ● ● ○
Clear Dual-Pane	● ○ ○ ○	○ ○ ○ ○	● ● ● ●	○ ○ ○ ○

Center of glass performance only. Ratings based on glass options as of January 2019. Visit [andersenwindows.com](http://andersenwindows.com) for ENERGY STAR map and NFRC total unit performance data.



### TIME-SAVING FILM

We help protect our products during delivery and construction with a translucent film on the glass. It also minimizes time spent masking on the jobsite, then peels away for a virtually spotless window.



Visit [andersenwindows.com/glass](http://andersenwindows.com/glass) for more details on our glass options.

### ADDITIONAL GLASS OPTIONS

**TEMPERED** safety glass, standard on patio doors

**LAMINATED** glass for added strength, enhanced security and sound control

**PATTERNED** glass lets in light while obscuring vision and adds a unique, decorative touch. Cascade and Reed patterns can be ordered with either a vertical or horizontal orientation.



Cascade

Fern



Obscure

Reed

### ART GLASS

With art glass from Andersen, you can add interest, create focal points and make your work stand out. These finely crafted inserts are available in two distinctly different series — Classic and Artisan — to complement any home's architecture. Visit [andersenwindows.com/artglass](http://andersenwindows.com/artglass) for more information.



### STORMWATCH® PROTECTION

Most Andersen 400 Series windows are available with impact-resistant glass and structural upgrades to meet the tough building codes of hurricane-prone coastal areas. See your local code official for specific requirements.



\* Andersen 400 Series products only with SmartSun glass with HeatLock coating (argon gas blend), no grilles, no capillary breather tubes. Excludes patterned/textured glass.



# GRILLE OPTIONS

Grille patterns are available in widths and configurations to fit any architectural style or the taste of any customer. We can match virtually any existing grille pattern and we'll even work with you and your customers to create custom patterns.

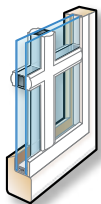

Permanent exterior  
Permanent interior  
with spacer

## FULL DIVIDED LIGHT

Permanently applied to the exterior and interior of the window with a spacer between the glass.



Permanent exterior  
Permanent interior

## SIMULATED DIVIDED LIGHT

Permanent grilles on the exterior and interior with no spacer between the glass. We also offer permanent exterior grilles with removable interior grilles.

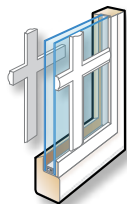

Permanent exterior  
Removable interior

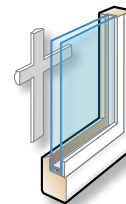

Removable interior

## CONVENIENT CLEANING OPTIONS

Removable interior grilles come off for easy cleaning. Finelight™ grilles-between-the-glass are installed between the glass panes and feature a contoured profile in 1" (25) and 3/4" (19) widths.



Finelight  
Grilles-  
Between-  
the-Glass\*

## GRILLE BAR WIDTHS

Actual size shown.



3/4" (19)



7/8" (22)



1 1/8" (29)



2 1/4" (59)



To see all of the standard patterns available for a specific window, refer to the detailed product sections in this product guide.

\* 7/8" (22), 1 1/8" (29) and 2 1/4" (57) not available in Finelight grilles-between-the-glass. Dimensions in parentheses are in millimeters.

# INSECT SCREEN OPTIONS

Exclusive Andersen® TruScene® insect screens provide more than 50% greater clarity than our conventional insect screens for a beautifully unobstructed view. And they let in more fresh air and sunlight while doing a better job of keeping out small insects.



## TRUSCENE INSECT SCREENS

For casement and awning windows, TruScene insect screen frames are available in stone, white, dark bronze, black or natural pine veneer that can be stained to match the window. Insect screen frames for all other windows are installed on the exterior of the window and match the unit's exterior color.

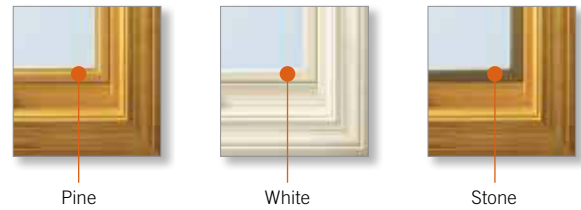

Pine | White | Stone | Black | Dark Bronze

## CONVENTIONAL INSECT SCREENS

Conventional insect screen frames are available in white, stone, dark bronze and black for casement and awning windows. Insect screen frames for all other windows are installed on the exterior of the window and match the unit's exterior color.

## CONFIGURATIONS

### DOUBLE-HUNG WINDOWS

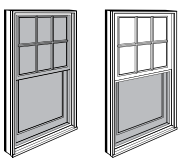

#### FULL OR HALF INSECT SCREEN

Full insect screens are available for Andersen venting windows. Andersen also offers the option of half insect screens for the lower sash of our Woodwright® and tilt-wash double-hung windows.

### GLIDING PATIO DOORS

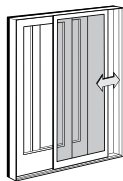

#### GLIDING INSECT SCREEN

Gliding insect screens are available for two- and four-panel doors.

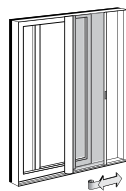

#### RETRACTABLE INSECT SCREEN

The retractable insect screen is installed on the exterior of the door and opens side to side across the width of the opening. When the insect screen is not in use, it neatly retracts into a small canister. Available for two-panel doors.

### HINGED INSWING PATIO DOORS

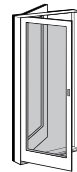

#### HINGED INSECT SCREEN

Available for single-panel doors.

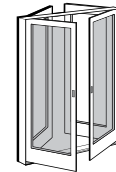

#### DOUBLE-HINGED INSECT SCREEN

Available for two-panel active-passive doors.

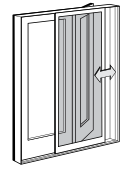

#### GLIDING INSECT SCREEN

Available for all two- and three-panel doors.

# SMART HOME SOLUTIONS

Andersen® smart home solutions provide increased security, convenience and peace of mind. Homeowners can manage the status of their windows and patio doors anytime and from anywhere with our VeriLock® security sensors and wireless open/closed sensors.\* To learn more, visit [andersenwindows.com/connect](http://andersenwindows.com/connect).



## VERILOCK SECURITY SENSORS

With the most advanced technology in the industry, VeriLock security sensors not only indicate whether windows and patio doors are open or closed, they even tell you if they are locked or unlocked†. No other sensor can do that.

### MAINTAINS WARRANTY

No drilling required which can void warranties.

### HELPS MAXIMIZE ENERGY EFFICIENCY

Windows that are closed but unlocked lose air at a rate up to 3X that of a closed and locked window.\*\* VeriLock sensors tell you which windows and patio doors are open or unlocked\* so you can help manage energy efficiency.

### PRESERVES BEAUTY

Available in a variety of colors to complement many Andersen hardware or interior finishes.



### COLOR OPTIONS



## WIRELESS OPEN/CLOSED SENSORS

These wireless sensors provide the peace of mind of knowing whether windows and patio doors are open or closed†.

### EASY INSTALLATION

No tools are required to install our sensors. Simply place the sensor on a window or patio door and line up the magnet with the sensor until the LED glows blue!

### MAINTAINS WARRANTY

No drilling required which can void warranties.

### COMPACT DESIGN

Sleek, compact design for a clean appearance, available in a variety of colors to blend in with the window or patio door.



### COLOR OPTIONS

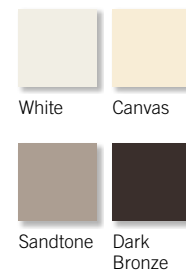

\* When properly configured and maintained with a professionally installed security system and/or self-monitoring system compatible with Honeywell® 5800 controls. See your Andersen supplier for more information.

\*\* Based on testing of thirty-two (32) A-Series double-hung windows. Air loss through unlocked windows will vary based on window type and age, pressure differential, temperatures inside and outside the home, altitude and application.

† See product installation for details.

‡ Not available on 400 Series tilt-wash double-hung windows.



# COMPARISON CHART

Use the quick reference chart below to decide which Andersen® 400 Series products best fit your project needs.

FEATURES		WINDOWS								PATIO DOORS	
		WOODRIGHT® DOUBLE-HUNG FULL-FRAME	WOODRIGHT DOUBLE-HUNG INSERT	TILT-WASH DOUBLE-HUNG FULL-FRAME	TILT-WASH DOUBLE-HUNG INSERT	NARROLINE® CONVERSION KIT	CASEMENT	AWNING	GLIDING	FRENCHWOOD® GLIDING	FRENCHWOOD HINGED INSWING
<b>LOW-MAINTENANCE EXTERIORS</b>											
	White	●	●	●	●	●	●	●	●	●	●
	Canvas	●	●	●	●		●	●	●		
	Sandtone	●	●	●	●	●	●	●	●	●	●
	Terratone	●	●	●	●	●	●	●	●	●	●
	Forest Green	●	●	●	●		●	●	●	●	●
	Dark Bronze	●	●	●	●		●	●	●		
	Black	●	●	●	●		●	●	●		
<b>INTERIORS*</b>											
	Maple	●	●							●	●
	Oak	●	●							●	●
	Pine	●	●	●	●	●	●	●	●	●	●
	White	●	●	●	●	●	●	●	●	●	●
	Sandtone							●			
	Dark Bronze			●	●		●	●	●		
	Black			●	●		●	●	●		
<b>EASY CLEANING</b>											
	Tilt-to-Clean Sash	●	●	●	●	●					
<b>GRILLES &amp; BLINDS</b>											
	Full Divided Light	●	●	●	●	●	●	●	●	●	●
	Simulated Divided Light	●	●	●	●	●	●	●	●	●	●
	Finelight™ Grilles-Between-the-Glass	●	●	●	●	●	●	●	●	●	●
	Removable Interior Grilles	●	●	●	●	●	●	●	●	●	●
	Blinds-Between-the-Glass (select sizes only)									●	●
<b>HIGH-PERFORMANCE GLASS</b> Additional glass options are available. See page 19 for details. For patio doors, all glass options are tempered.											
	Low-E4®	●	●	●	●	●	●	●	●	●	●
	Low-E4 Sun	●	●	●	●	●	●	●	●	●	●
	Low-E4 SmartSun™	●	●	●	●	●	●	●	●	●	●
	Clear Dual-Pane						●	●			
	HeatLock® Coating	●	●	●	●	●	●	●	●	●	●
<b>PERFORMANCE OPTION</b>											
	Stormwatch® Protection	PG Upgrade		●			●	●			
<b>STANDARD SIZES</b>											
	Minimum Width	1'-9 5/8"	1'-4 1/2"	1'-9 5/8"	1'-9 1/4"	Fits Narroline windows made after 1967	1'-5"	2'-0 1/8"	2'-11 1/4"	4'-11 1/4"	2'-6 1/8"
	Maximum Width	3'-9 5/8"	3'-9 5/8"	3'-9 5/8"	3'-8 7/8"		2'-11 15/16"	5'-11 7/8"	5'-11 1/4"	15'-9"	8'-11 1/8"
	Minimum Height	3'-0 7/8"	2'-3 3/4"	3'-0 7/8"	3'-0 3/8"		2'-0 1/8"	1'-5"	1'-10 1/4"	6'-7 1/2"	6'-7 1/2"
	Maximum Height	6'-4 7/8"	6'-5"	7'-8 7/8"	7'-6 5/8"		5'-11 7/8"	4'-0"	4'-11 1/4"	7'-11 1/2"	7'-11 1/2"
	<b>CUSTOM SIZES</b> ▲	●	●	●	●		●	●		●	●

To learn more about other traditional and contemporary style Andersen patio door options, visit [andersenwindows.com/doors](http://andersenwindows.com/doors).

\* Some product configurations not available in all colors or wood species, see your Andersen supplier for details.

# NOTES

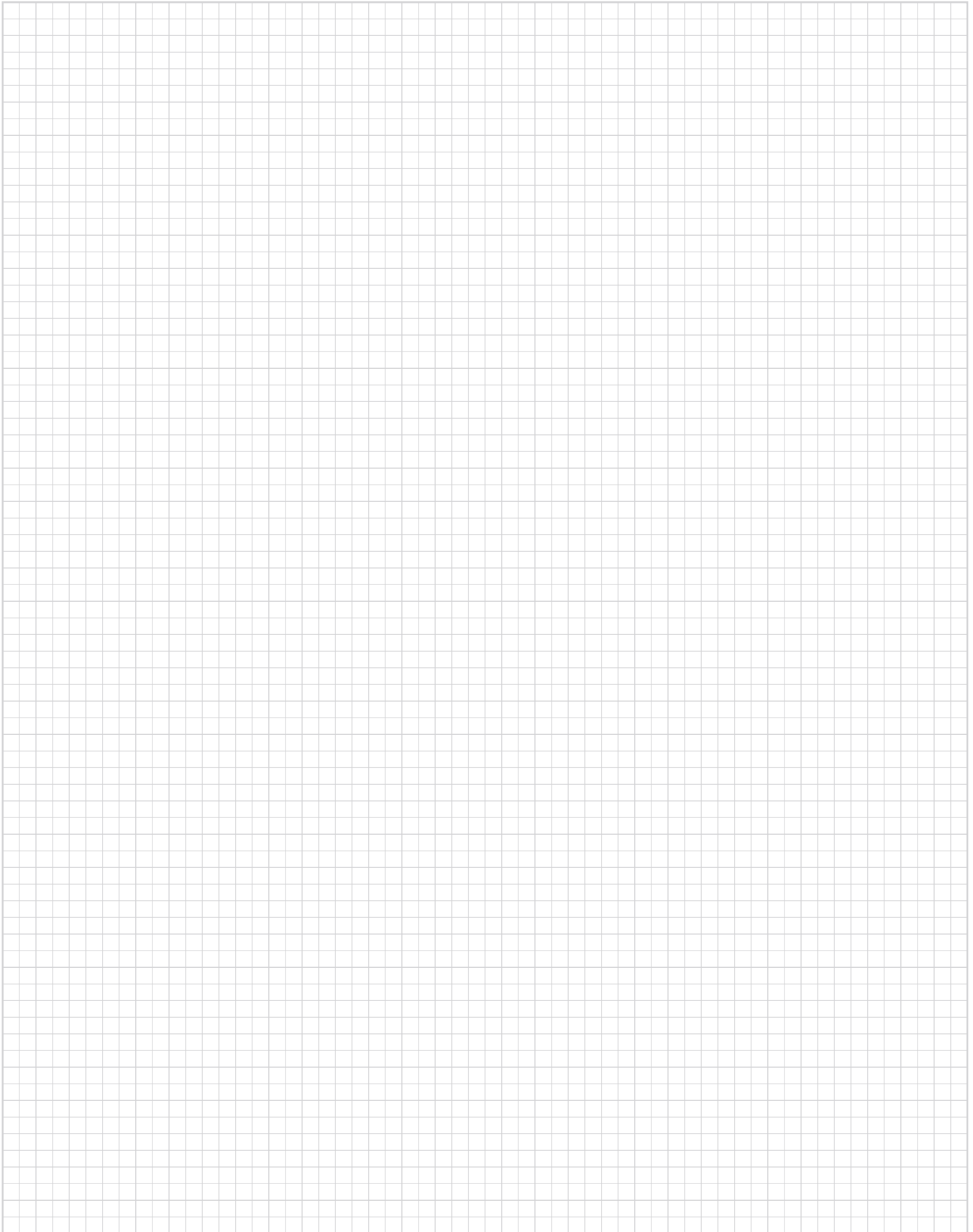

# CASEMENT & AWNING WINDOWS



## SECTION REFERENCE

Alignment Grid .....	22-23
Tables of Sizes .....	24-28
Specifications .....	29-32
Custom Sizing .....	33
Grille Patterns .....	34
Window Details .....	35-36
Joining Details.....	36
Combination Designs .....	181
Product Performance.....	194

**CUSTOM SIZING**  
in 1/8" (3) increments



Dimensions in parentheses are in millimeters.

# CASEMENT & AWNING WINDOWS

## FEATURES

### Frame

**A** A seamless one-piece, rigid vinyl frame cover is secured to the exterior of the frame to protect the wood frame from moisture and maintain an attractive appearance while minimizing maintenance.

**B** The seamless rigid exterior vinyl cover extends 1 3/8" (35) around the perimeter of the unit. This creates a flange to help seal the unit to the structure.

**C** Wood frame members are treated with a water-repellent preservative for long-lasting\* protection and performance.

**D** Interior stops are unfinished pine. Low-maintenance prefinished white, dark bronze and black interiors are also available.

### Sash

**E** Rigid vinyl encases the entire sash — a vinyl weld protects each sash corner for superior weathertightness. It maintains an attractive appearance and minimizes maintenance.

**F** Wood core members provide excellent structural stability and energy efficiency.

**G** Flexible bulb weatherstrip or vinyl closed-cell foam weatherstrip is factory installed on the perimeter of the sash.

### Glass

**H** A glazing bead and silicone provide superior weathertightness and durability.

**I** High-Performance glass options include:

- Low-E4® glass
- Low-E4 HeatLock® glass
- Low-E4 Sun glass
- Low-E4 SmartSun™ glass
- Low-E4 SmartSun HeatLock glass

Tempered glass and other glass options are available. Contact your Andersen supplier.

A removable translucent film helps shield the glass from damage during delivery and construction and simplifies finishing at the jobsite.

### Patterned Glass

Patterned glass options are available. See page 12 for more details.

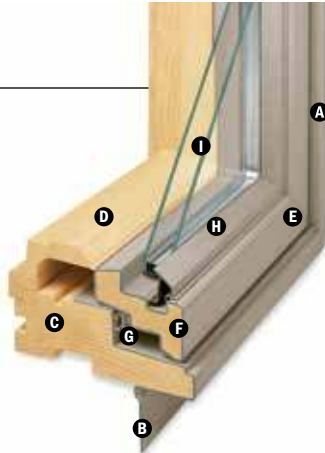

### Hardware

#### Smooth Control Hardware System



The smooth control hardware system employs a worm gear drive for easy operation. Units with a wash mode have hinges that move the sash away from the frame to

provide easier glass cleaning. **CXW15**, **CXW155**, **CXW16** and **CXW25** sizes are not available with wash mode. Hardware option and finish must be specified. Operator handle and cover sold separately.

#### Single-Actuation Casement Lock



On casement windows, a single-actuation lock easily releases all locking points on casement sash while the reach-out action eliminates binding when closing. The lock handle is offered in finishes that coordinate with your specified hardware option.

#### Awning Sash Locks



Awning sash locks provide an added measure of security and weathertightness. Hardware style and finish options are compatible with Andersen® casement windows to ensure consistency in appearance when used in combination designs.

## StormWATCH PROTECTION

Casement and awning windows are available with Stormwatch® Protection. Visit [andersenwindows.com/coastal](http://andersenwindows.com/coastal) for more details.

### Performance Grade (PG) Upgrade

Performance upgrades are available for select casement and awning sizes, allowing these

units to achieve higher performance ratings. Performance Grade (PG) Ratings are more comprehensive than Design Pressure (DP) Ratings for measuring product performance. Contact your Andersen supplier for availability. For up-to-date performance information of individual products, visit [andersenwindows.com](http://andersenwindows.com).

## EXTERIOR

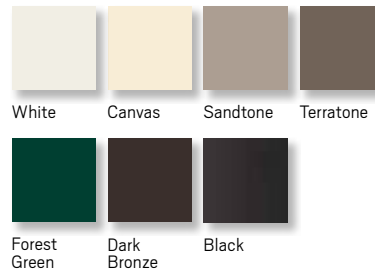

## INTERIOR



Naturally occurring variations in grain, color and texture of wood make each window one of a kind. All wood interiors are unfinished unless a prefinished option is specified.

## HARDWARE FINISHES



Distressed bronze and oil rubbed bronze are "living" finishes that will change with time and use.

## CASEMENT & AWNING HARDWARE OPTIONS†

### CLASSIC SERIES™



Stone | White

### ESTATE™



**Antique Brass** | Bright Brass  
Brushed Chrome | Distressed Bronze  
Distressed Nickel | Oil Rubbed Bronze  
Polished Chrome | Satin Nickel

### TRADITIONAL FOLDING



Antique Brass | Black | Bright Brass  
**Distressed Bronze** | Distressed Nickel  
Gold Dust | Oil Rubbed Bronze | Satin Nickel  
Stone | White

### CONTEMPORARY FOLDING



Black | Bright Brass  
Gold Dust | Oil Rubbed Bronze  
**Satin Nickel** | Stone | White

Folding handle avoids interference with window treatments.  
Bold name denotes finish shown.

\* Visit [andersenwindows.com/warranty](http://andersenwindows.com/warranty) for details.

\*\* Dark bronze and black interiors are only available with dark bronze and black exteriors respectively.

† Hardware sold separately.

Dimensions in parentheses are in millimeters.

Printing limitations prevent exact replication of colors and finishes.

See your Andersen supplier for actual color and finish samples.

## ACCESSORIES Sold Separately

### Frame

#### Extension Jamb



Standard jamb depth is 2 1/8" (73). Extension jambs are available in unfinished pine or prefinished white. Some sizes may be veneered.

Factory-applied and non-applied interior extension jambs are available in 1/16" (1.5) increments between 4 9/16" (116) and 7 1/8" (181). Extension jambs can be factory applied to either three sides (stool and apron application) or four sides (picture frame casing).

#### Thick Replacement Extension Jambs

To help preserve original alignment of trim and paint lines in replacement situations, special 1 1/8" (29) thick replacement extension jambs are available. Factory-applied and non-applied extension jambs are available in 1/16" (1.5) increments between 4 9/16" (116) and 7 1/8" (181). Non-applied extension jambs are available in 12' (3658) lineals. Detail on page 34.

#### Drywall Return Bead



A drywall return bead is available in a narrow or wide dimension with unfinished pine or prefinished white interiors. Can be ordered factory-applied or in non-applied lineals. Detail on page 34.

For more information about **glass, patterned glass, art glass, grilles and TruScene insect screens**, see pages 12-14.

For more information about **combination designs, product performance, installation instructions and accessories**, see pages 181-211 or visit [andersenwindows.com](http://andersenwindows.com).

### Hardware

#### Corrosion-Resistant Components



Corrosion-resistant hinge and operator arm hardware is designed for applications in harsh and corrosive environments such as heavy industrial or coastal areas.

#### Window Opening Control Device Kit



A Window Opening Control Device Kit is available, which limits sash travel to less than 4" (102) when the window is first opened. Available factory applied or field applied in stone, white and black.

#### Special Use Operator Handles

Available in Classic Series™ design only.

##### Compact Operator Handle



Specially designed for use in situations

where blinds or other window treatments interfere with standard operator handle. Available in white or stone finish.

##### Easy-Grip Handle

Larger knob makes it easier to grip and operate. Available in white or stone finish.



##### Metal T-Handle



Our smallest operator handle, the metal T-handle, may make it more difficult for young children (5 and under) to open the window. For more information on child safety, write:

Andersen Corporation  
**LookOut for Kids® Program**  
100 Fourth Avenue North  
Bayport, MN 55003  
Call 1-800-313-8889 or email us at [lofk@andersencorp.com](mailto:lofk@andersencorp.com).

#### Operator Spline Cover



An operator spline cover is an attractive cap that covers the roto operator stud when the handle has been removed to control access or operation of the window. The operator spline cover should not be used on any window designated or intended for emergency escape or rescue. Please consult your local building code official for local egress code requirements.

#### Power Operator for Awning Windows



Awning windows can be ordered with an operator enhanced by PowerAssist™ technology that opens and closes the window with the touch of a button. Easy to install, the 24-volt system features a concealed window power drive, battery backup in case of a power outage and a moisture sensor that automatically closes the window when it rains. A wireless remote control is available (sold separately).

The PowerAssist system is controlled by a wall-mounted console, which includes a power box, battery, touch pad and mounting bracket. Windows can be ordered factory-prepped to save time or they can be ordered as a field kit. Power driver requires field installation. PowerAssist technology eliminates need for sash locks. Available for windows up to five feet wide. Not available for units with Stormwatch® Protection or performance upgrades.

#### Security Sensors

##### VeriLock® Sensors

VeriLock sensors are available in five colors. See page 15 for details.

##### Open/Closed Sensors

Wireless open/closed sensors are available in four colors. See page 15 for details.

#### Glass

##### Andersen® Art Glass

Andersen art glass panels come in a variety of original patterns. See pages 173-174 for details on Andersen art glass. Visit [andersenwindows.com/artglass](http://andersenwindows.com/artglass) for details and pattern information.

### Insect Screens

#### TruScene® Insect Screen



Exclusive Andersen TruScene insect screens provide over 50% more clarity than our conventional insect screens for a beautiful unobstructed view. They allow more fresh air and sunlight in while doing a better job of keeping out small insects. For casement and awning windows, frames are available in stone, white, dark bronze or black or with pine veneer interiors to blend with the wood interior of the window.

#### Conventional Insect Screen

Conventional insect screens have charcoal powder-coated aluminum screen mesh. Available with frames in white, stone, dark bronze or black.

#### Grilles

Grilles are available in a variety of configurations and widths. For casement and awning window grille patterns, see page 34.

#### Exterior Trim

This product is available with Andersen exterior trim. See pages 175-180 for details.

#### CAUTION:

- Painting and staining may cause damage to rigid vinyl.
- Do not paint 400 Series windows with white, canvas, Sandtone, forest green, dark bronze or black exterior colors.
- Andersen does not warrant the adhesion or performance of homeowner-applied paint over vinyl or other factory-coated surfaces
- 400 Series windows in Terratone color may be painted any color lighter than Terratone color using quality oil-based or latex paint.
- For vinyl painting instructions and preparation, contact your Andersen supplier.
- Do not paint weatherstrip.
- Creosote-based stains should not come in contact with Andersen products.
- Abrasive cleaners or solutions containing corrosive solvents should not be used on Andersen products.

\* Visit [andersenwindows.com/warranty](http://andersenwindows.com/warranty) for details. Dimensions in parentheses are in millimeters.

# CASEMENT & AWNING WINDOWS

## Alignment Grid for Standard Size Casement, Awning, Picture and Transom Windows

	1'-5"	1'-8 1/2"	2'-0 1/8"	2'-4 3/8"	2'-7 1/2"	2'-9 3/4"	2'-11 15/16"	3'-4 3/4"	3'-4 13/16"	4'-0"									
<b>Specialty</b>	(432)	(521)	(613)	(721)	(800)	(857)	(913)	(1035)	(1037)	(1219)									
See the specialty window section starting on page 117 for these and other specialty shapes and sizes.			AFC106 AFC11	AFCW106 AFCW11	CTQC1	CTQCW1 CTQCX1	AFCP3006 AFCP301	CTQA3	CTCXW1	AFC206 AFC21									
<b>Transom</b>										CTC2									
1'-0"	(305)	CTR1510 CTR1810	CTR2010	CTR2410	CTR2810	CTR2910	CTR3010	PTR3010	CTR3410 CTR21810	PTR3510	CTR4010 CTR22010	PTR4010							
<b>Awning</b>																			
1'-5"	(432)		AR21	AR251	AR281		AR31		AR351	AR41	AR221								
1'-8 1/2"	(521)		AN21	AN251	AN281		AN31		AN351	AN41	AN221								
2'-0 1/8"	(613)		A21	A251	A281		A31		A351	A41	A221								
2'-4 3/8"	(721)		AW21	AW251	AW281		AW31		AW351	AW41	AW221								
2'-7 1/2"	(800)			AX251	AX281		AX31		AX351	AX41									
2'-11 15/16"	(913)				AXW281		AXW31		AXW351	AXW41									
3'-4 3/4"	(1035)						A335		A3535										
<b>Casement, Awning and Picture</b>																			
2'-0 1/8"	(613)	CR12	CN12	C12	CW12			CN22		C22									
2'-4 3/8"	(721)	CR125	CN125	C125	CW125	CX125		CN225		C225									
2'-11 15/16"	(913)	CR13	CN13	C13	CW13	CX13	CR23	CXW13	P3030	CN23	P3530	C23	P4030						
3'-4 13/16"	(1037)	CR135	CN135	C135	CW135	CX135	CR235	CXW135	P3035	CN235	P3535	C235	P4035						
4'-0"	(1219)	CR14	CN14	C14	A212	CW14	CX14	CR24	CXW14	A312	AP32V	P3040	CN24	AP352V	P3540	C24	AP42V	P4040	
4'-4 13/16"	(1341)	CR145	CN145	C145	CW145	CX145	CR245	CXW145	P3045	CN245	P3545	C245	P4045						
4'-11 7/8"	(1521)	CR15	CN15	C15	CW15	CX15	CR25	CXW15	PA3050*	P3050	CN25	PA3550*	P3550	C25	P4050				
5'-4 13/16"	(1646)	CR155	CN155	C155	CW155	CX155	CR255	CXW155	P3055	CN255	P3555	C255	P4055						
5'-11 7/8"	(1826)	CR16	CN16	C16	A213	CW16	CX16	CR26	CXW16	PA3060	AXW312**	A313	P3060	CN26	PA3560	P3560	C26	PA4060	P4060

\* Dimensions in parentheses are in millimeters.

\* Actual height of 4'-11 13/16" (1519).

\*\* Actual height of 5'-11 5/8" (1819).

4'-4 13/16" (1341)	4'-8 1/2" (1435)	4'-11 7/8" (1521)	5'-1" (1549)	5'-2 3/4" (1594)	5'-4 13/16" (1646)	5'-11 5/8" (1819)	5'-11 7/8" (1826)	7'-0 5/8" (2149)

Similar jamb profiles enable these standard-size windows to be combined in multiple combinations. Custom-size windows are also available.

Window widths and heights shown. See individual size charts for additional dimensions.

In addition to venting configurations shown, other standard configurations are available.

\* Dimensions in parentheses are in millimeters.

# CASEMENT & AWNING WINDOWS

**Table of Casement and Transom Window Sizes**

Scale 1/8" (3) = 1'-0" (305) – 1:96

Window Dimension	1'-5"	1'-8 1/2"	2'-0 1/8"	2'-4 3/8"	2'-7 1/2"	2'-11 15/16"	2'-9 3/4"	3'-4 3/4"	4'-0"	4'-8 1/2"
	(432)	(521)	(613)	(721)	(800)	(913)	(857)	(1035)	(1219)	(1435)
<b>Minimum Rough Opening</b>	1'-5 1/2"	1'-9"	2'-0 5/8"	2'-4 7/8"	2'-8"	3'-0 1/2"	2'-10 1/4"	3'-5 1/4"	4'-0 1/2"	4'-9"
	(445)	(533)	(625)	(733)	(813)	(927)	(870)	(1048)	(1232)	(1448)
Unobstructed Glass (casement, single sash only)	12 5/8"	16 1/8"	19 3/4"	24"	27 1/8"	31 9/16"	12 5/8"	16 1/8"	19 3/4"	24"
	(321)	(410)	(502)	(610)	(689)	(802)	(321)	(410)	(502)	(610)
Unobstructed Glass (transom, single sash only)	12 3/16"	15 11/16"	19 5/16"	23 9/16"	26 11/16"	31 1/8"	28 15/16"	35 15/16"	43 3/16"	51 11/16"
	(310)	(398)	(491)	(599)	(678)	(791)	(735)	(913)	(1097)	(1313)

**CUSTOM WIDTHS – 17" to 84 5/8"**

Window Dimension	17"	18 1/2"	20 1/8"	24 3/8"	27 1/2"	31 15/16"	29 3/4"	34 3/4"	40"	48 1/2"
1'-0"	(305)	(318)	(318)	(318)	(318)	(318)	(318)	(318)	(318)	(318)
	CTR1510	CTR1810	CTR2010	CTR2410	CTR2810	CTR3010	CTR2910	CTR3410	CTR4010	CTR4810
1'-0"	(305)	(318)	(318)	(318)	(318)	(318)	(318)	(318)	(318)	(318)
								CTR21810	CTR22010	CTR22410

**CUSTOM WIDTHS – 17" to 35 15/16"**

Window Dimension	17"	18 1/2"	20 1/8"	24 3/8"	27 1/2"	31 15/16"	29 3/4"	34 3/4"	40"	48 1/2"	
2'-0 1/8"	(613)	(625)	(625)	(625)	(625)	(625)	(625)	(625)	(625)	(625)	
	CR12	CN12	C12	CW12*				CN22	C22	CW22*	
2'-4 3/8"	(721)	(733)	(733)	(733)	(733)	(733)	(733)	(733)	(733)	(733)	
	CR125	CN125	C125	CW125*	CX125			CN225	C225	CW225*	
2'-11 15/16"	(913)	(927)	(927)	(927)	(927)	(927)	(927)	(927)	(927)	(927)	
	CR13	CN13	C13	CW13*	CX13	CXW13		CR23	CN23	C23	CW23*
3'-4 13/16"	(1037)	(1051)	(1051)	(1051)	(1051)	(1051)	(1051)	(1051)	(1051)	(1051)	
	CR135	CN135	C135	CW135*	CX135°	CXW135°		CR235	CN235	C235	CW235*
4'-0"	(1219)	(1232)	(1232)	(1232)	(1232)	(1232)	(1232)	(1232)	(1232)	(1232)	
	CR14	CN14	C14	CW14*	CX14°	CXW14°		CR24	CN24	C24	CW24*
4'-4 13/16"	(1341)	(1356)	(1356)	(1356)	(1356)	(1356)	(1356)	(1356)	(1356)	(1356)	
	CR145	CN145	C145	CW145*	CX145°	CXW145°		CR245	CN245	C245	CW245*
4'-11 7/8"	(1521)	(1534)	(1534)	(1534)	(1534)	(1534)	(1534)	(1534)	(1534)	(1534)	
	CR15	CN15	C15	CW15*	CX15°	CXW15**		CR25	CN25	C25	CW25*
5'-4 13/16"	(1646)	(1660)	(1660)	(1660)	(1660)	(1660)	(1660)	(1660)	(1660)	(1660)	
	CR155	CN155	C155	CW155*	CX155°	CXW155**		CR255	CN255	C255	CW255*
5'-11 7/8"	(1826)	(1838)	(1838)	(1838)	(1838)	(1838)	(1838)	(1838)	(1838)	(1838)	
	CR16	CN16	C16	CW16*	CX16°	CXW16**		CR26	CN26	C26	CW26*

\*"Window Dimension" always refers to outside frame to frame dimension.  
 • "Minimum Rough Opening" dimensions may need to be increased to allow for use of building wraps, flashing, sill panning, brackets, fasteners or other items. See pages 210-211 for more details.  
 ° Dimensions in parentheses are in millimeters.  
 ° Meet or exceed clear opening area of 5.7 sq.ft. or 0.53 m<sup>2</sup>, clear opening width of 20" (508) and clear opening height of 24" (610) with appropriate hinge specified. See tables on pages 29-30.  
 \* Meet clear opening width of 20" (508) using hinge with wash mode and control bracket (bracket can be pivoted for cleaning position) and meet clear opening width of 22" (559) using hinge for widest clear opening.  
 \*\* Available with straight-arm operators (hinged for widest clear opening) only.

5'-2 3/4" (1594)	5'-11 5/8" (1819)	5'-1" (1549)	5'-11 7/8" (1826)	7'-0 5/8" (2149)
5'-3 1/4" (1607)	6'-0 1/8" (1832)	5'-1 1/2" (1562)	6'-0 3/8" (1838)	7'-1 1/8" (2162)
27 1/8" (689)	31 9/16" (802)	16 1/8" (410)	19 3/4" (502)	24" (610)
57 15/16" (1472)	66 13/16" (1697)	56 3/16" (1427)	67 1/16" (1703)	79 13/16" (2027)



Custom-size windows are available in 1/8" (3) increments. Windows can also be custom sized to match standard sizes ending in a sixteenth of an inch. **Single windows only.** See page 33 for custom sizes and specifications.

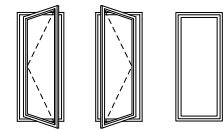
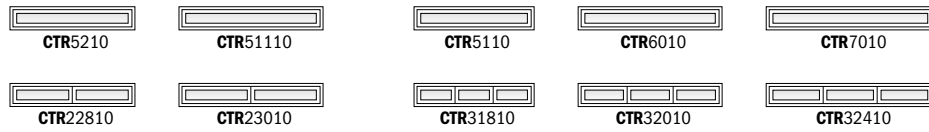

Left Right Stationary

Choose left, right or stationary as viewed from the exterior. In addition to venting shown in table, other standard configurations are available for single, twin and triple windows. Transom (CTR) windows are stationary only.

Twin and triple windows shown have one continuous outer frame.

**Transom (CTR) windows can be used over casement or awning windows and may be rotated 90° and used as a sidelight with casement, awning or picture windows.**

Grille patterns shown on page 34.

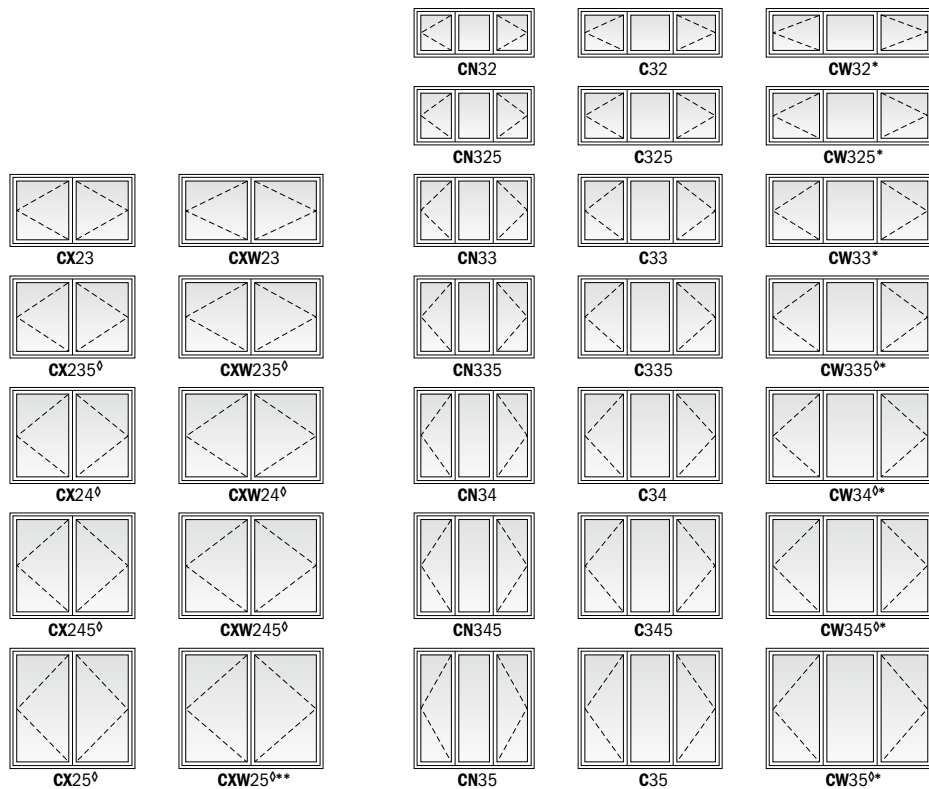

\*"Window Dimension" always refers to outside frame to frame dimension.

\*\*Minimum Rough Opening dimensions may need to be increased to allow for use of building wraps, flashing, sill panning, brackets, fasteners or other items. See pages 210-211 for more details.

\*Dimensions in parentheses are in millimeters.

ØMeet or exceed clear opening area of 5.7 sq.ft. or 0.53 m<sup>2</sup>, clear opening width of 20" (508) and clear opening height of 24" (610) with appropriate hinge specified. See tables on pages 29-30.

\*Meet clear opening width of 20" (508) using hinge with wash mode and control bracket (bracket can be pivoted for cleaning position) and meet clear opening width of 22" (559) using hinge for widest clear opening.

\*\*Available with straight-arm operators (hinged for widest clear opening) only.

# CASEMENT & AWNING WINDOWS

## Table of Awning Window Sizes

Scale 1/8" (3) = 1'-0" (305) – 1:96

Window Dimension	2'-0 1/8" (613)	2'-4 3/8" (721)	2'-7 1/2" (800)	2'-11 15/16" (913)	3'-4 13/16" (1037)	4'-0" (1219)	4'-4 13/16" (1341)	4'-11 7/8" (1521)	5'-4 13/16" (1646)	5'-11 7/8" (1819)
<b>Minimum Rough Opening</b>	2'-0 5/8" (625)	2'-4 7/8" (733)	2'-8" (813)	3'-0 1/2" (927)	3'-5 3/8" (1051)	4'-0 1/2" (1232)	4'-5 3/8" (1356)	5'-0 3/8" (1534)	5'-5 3/8" (1660)	6'-0 3/8" (1832)
Unobstructed Glass (single sash only)	19 5/16" (491)	23 9/16" (598)	26 11/16" (678)	31 1/8" (791)	36" (914)	43 3/16" (1097)	48" (1219)	55 1/16" (1399)	60" (1524)	67 1/16" (1703)

**CUSTOM WIDTHS – 24 1/8" to 71 7/8"**

**CUSTOM HEIGHTS – 17" to 35 15/16"**

1'-5" (432)	AR21	AR251	AR281	AR31	AR351	AR41	AR451	AR51	AR551	AR61
1'-8 1/2" (521)	AN21	AN251	AN281	AN31	AN351	AN41	AN451	AN51	AN551	AN61
2'-0 1/8" (613)	A21	A251	A281	A31	A351	A41	A451	A51	A551	A61
2'-4 3/8" (721)	AW21	AW251	AW281	AW31	AW351	AW41	AW451	AW51	AW551	AW61
2'-7 1/2" (800)		AX251	AX281	AX31	AX351	AX41	AX451	AX51	AX551	AX61
2'-11 15/16" (913)										
3'-0 1/2" (927)										
3'-4 3/4" (1035)				A335	A3535					
3'-5 1/4" (1048)										
3'-6 3/8" (924)										
4'-0" (1219)				AP32V	AP352V	AP42V				

**CUSTOM WIDTHS – 24 1/8" to 48" venting only**

**CUSTOM HEIGHTS – 35 7/8" to 48" venting only**

**CUSTOM WIDTHS – 59 7/8" to 71 7/8" stationary only**

**CUSTOM HEIGHTS – 31 1/2" to 35 15/16" stationary only**













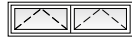





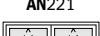

									AXW551	AXW61
--	--	--	--	--	--	--	--	--	--------	-------

Window Dimension	2'-0 1/8" (613)	2'-11 15/16" (913)	2'-11 15/16" (913)	3'-4 13/16" (1037)	4'-0" (1219)	2'-0 1/8" (613)	2'-11 15/16" (913)
<b>Minimum Rough Opening</b>	2'-0 5/8" (625)	3'-0 1/2" (927)	3'-0 1/2" (927)	3'-5 3/8" (1051)	4'-0 1/2" (1232)	2'-0 5/8" (625)	3'-0 1/2" (927)
4'-0" (1219)	A212 (A21/A21)		A312 (A31/A31)				
4'-11 13/16" (1519)			PA3050 (AXW31/A31)	PA3550 (AXW351/A351)			
5'-11 9/8" (1826)			PA3060 (AP32V/A31)	PA3560 (AP352V/A351)	PA4060 (AP42V/A41)		
6'-0 1/8" (1832)	AXW312 (AXW31/AXW31)					A213 (A21/A21/A21)	A313 (A31/A31/A31)

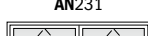
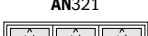
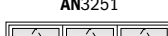
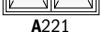
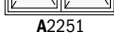
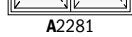
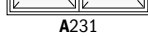
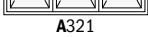
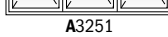
\* "Window Dimension" always refers to outside frame to frame dimension.  
 \* "Minimum Rough Opening" dimensions may need to be increased to allow for use of building wraps, flashing, sill panning, brackets, fasteners or other items. See pages 210-211 for more details.  
 \* Dimensions in parentheses are in millimeters.

4'-0" (1219)	4'-8 1/2" (1435)	5'-2 3/4" (1594)	5'-11 5/8" (1826)	5'-11 7/8" (1826)	7'-0 5/8" (2149)
4'-0 1/2" (1232)	4'-9" (1448)	5'-3 1/4" (1607)	6'-0 1/8" (1832)	6'-0 3/8" (1838)	7'-1 1/8" (2162)
19 5/16" (491)	23 9/16" (598)	26 11/16" (678)	31 1/8" (1703)	19 5/16" (491)	23 9/16" (598)

 <b>AR221</b>	 <b>AR2251</b>	 <b>AR2281</b>	 <b>AR231</b>	 <b>AR321</b>	 <b>AR3251</b>
 <b>AN221</b>	 <b>AN2251</b>	 <b>AN2281</b>	 <b>AN231</b>	 <b>AN321</b>	 <b>AN3251</b>
 <b>A221</b>	 <b>A2251</b>	 <b>A2281</b>	 <b>A231</b>	 <b>A321</b>	 <b>A3251</b>
 <b>AW221</b>	 <b>AW2251</b>	 <b>AW2281</b>	 <b>AW231</b>	 <b>AW321</b>	 <b>AW3251</b>
 <b>AX2251</b>	 <b>AX2281</b>	 <b>AX231</b>			
	 <b>AXW2281</b>	 <b>AXW231</b>			



Custom-size windows are available in 1/8" (3) increments. Windows can also be custom sized to match standard sizes ending in a sixteenth of an inch. **Single windows only.** See page 33 for custom sizes and specifications.

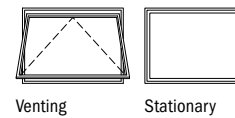

Choose venting or stationary. **AXW551** and **AXW61** windows are stationary only. In addition to venting shown in table, other standard configurations are available for twin, triple and stacked windows.

Twin, triple and stacked windows shown have one continuous outer frame.

**Awning window must be installed to vent as shown and should not be rotated and used as a hopper.**

**Transom (CTR) windows (shown on page 24-25) can be used over casement or awning windows and may be rotated 90° and used as a sidelight with casement, awning or picture windows.**

Grille patterns shown on page 34.

\*"Window Dimension" always refers to outside frame to frame dimension.  
 \*\*"Minimum Rough Opening" dimensions may need to be increased to allow for use of building wraps, flashing, sill panning, brackets, fasteners or other items. See pages 210-211 for more details.  
 •Dimensions in parentheses are in millimeters.

# CASEMENT & AWNING WINDOWS

**Table of Picture and Transom Window Sizes**

Scale 1/8" (3) = 1'-0" (305) – 1:96

Unit Dimension	2'-11 15/16"	3'-4 13/16"	4'-0"	4'-4 13/16"	4'-11 7/8"	5'-4 13/16"	5'-11 7/8"
	(913)	(1037)	(1219)	(1341)	(1521)	(1646)	(1826)
<b>Minimum Rough Opening</b>	3'-0 1/2"	3'-5 3/8"	4'-0 1/2"	4'-5 3/8"	5'-0 3/8"	5'-5 3/8"	6'-0 3/8"
	(927)	(1051)	(1232)	(1356)	(1534)	(1660)	(1838)
Unobstructed Glass	31 1/8"	36"	43 3/16"	48"	55 1/16"	60"	67 1/16"
	(791)	(914)	(1097)	(1219)	(1399)	(1524)	(1703)

		CUSTOM WIDTHS – 36" to 71 7/8"						
		CUSTOM WIDTHS – 35 15/16" to 59 7/8"					CUSTOM WIDTHS – 60" to 71 7/8"	
1'-0" (305)	1'-0 1/2" (318)	PTR3010 PTR3510 PTR4010 PTR4510 PTR5010					PTR5510 PTR6010	
2'-11 15/16" (913)	3'-0 1/2" (927)	P3030	P3530	P4030	P4530	P5030	P5530	P6030
3'-4 13/16" (1037)	3'-5 3/8" (1051)	P3035	P3535	P4035	P4535	P5035	P5535	P6035
4'-0" (1219)	4'-0 1/2" (1232)	P3040	P3540	P4040	P4540	P5040	P5540	P6040
4'-4 13/16" (1341)	4'-5 3/8" (1356)	P3045	P3545	P4045	P4545	P5045	P5545	P6045
4'-11 7/8" (1521)	5'-0 3/8" (1534)	P3050	P3550	P4050	P4550	P5050	P5550	P6050
5'-4 13/16" (1646)	5'-5 3/8" (1660)	P3055	P3555	P4055	P4555	P5055		
5'-11 7/8" (1826)	6'-0 3/8" (1838)	P3060	P3560	P4060	P4560	P5060		
	67 1/16" (1703)							



Custom-size windows are available in 1/8" (3) increments. Windows can also be custom sized to match standard sizes ending in a sixteenth of an inch. See page 33 for custom sizes and specifications.

**Picture and transom (PTR) windows may be rotated 90° to align with casement or awning windows.**

Grille patterns shown on page 34.

• "Window Dimension" always refers to outside frame to frame dimension.  
 • "Minimum Rough Opening" dimensions may need to be increased to allow for use of building wraps, flashing, sill panning, brackets, fasteners or other items. See pages 210-211 for more details.  
 • Dimensions in parentheses are in millimeters.

**Casement Window Opening and Area Specifications**

Window Number	Clear Opening Area		Clear Opening in Full Open Position			Glass Area Sq. Ft./ (m <sup>2</sup> )	Vent Area		Top of Subfloor to Top of Inside Sill Stop Inches/(mm)	Overall Window Area Sq. Ft./ (m <sup>2</sup> )
	Hinge for Widest Clear Opening Sq. Ft./ (m <sup>2</sup> )	Hinge with Wash Mode Sq. Ft./ (m <sup>2</sup> )	Hinge for Widest Clear Opening Inches/(mm)	Hinge with Wash Mode Inches/(mm)	Height Inches/(mm)		Hinge for Widest Clear Opening Sq. Ft./ (m <sup>2</sup> )	Hinge with Wash Mode Sq. Ft./ (m <sup>2</sup> )		
CR12	—	1.0 (0.09)	—	7 5/16" (186)	19 1/4" (489)	1.7 (0.16)	—	1.5 (0.14)	60 9/16" (1538)	2.8 (0.26)
CR125	—	1.2 (0.11)	—	7 5/16" (186)	23 7/16" (595)	2.0 (0.19)	—	1.8 (0.17)	56 3/8" (1432)	3.3 (0.31)
CR13	—	1.6 (0.15)	—	7 5/16" (186)	31 1/16" (789)	2.7 (0.25)	—	2.4 (0.22)	48 3/4" (1238)	4.2 (0.39)
CR135	—	1.8 (0.17)	—	7 5/16" (186)	35 15/16" (913)	3.1 (0.29)	—	2.7 (0.25)	43 7/8" (1114)	4.8 (0.45)
CR14	—	2.2 (0.20)	—	7 5/16" (186)	43 1/8" (1095)	3.8 (0.35)	—	3.3 (0.31)	36 11/16" (932)	5.7 (0.53)
CR145	—	2.4 (0.22)	—	7 5/16" (186)	47 15/16" (1218)	4.2 (0.39)	—	3.6 (0.33)	31 7/8" (810)	6.2 (0.58)
CR15	—	2.8 (0.26)	—	7 5/16" (186)	55" (1397)	4.8 (0.45)	—	4.2 (0.39)	24 13/16" (630)	7.1 (0.66)
CR155	—	3.1 (0.29)	—	7 5/16" (186)	59 15/16" (1522)	5.2 (0.48)	—	4.5 (0.42)	19 7/8" (505)	7.7 (0.72)
CR16	—	3.4 (0.32)	—	7 5/16" (186)	67" (1702)	5.9 (0.55)	—	5.1 (0.47)	12 13/16" (325)	8.5 (0.79)
CR23	—	1.6 (0.15)	—	7 5/16" (186)	31 1/16" (789)	5.4 (0.50)	—	4.7 (0.44)	48 3/4" (1238)	8.4 (0.78)
CR235	—	1.8 (0.17)	—	7 5/16" (186)	35 15/16" (913)	6.3 (0.59)	—	5.4 (0.50)	43 7/8" (1114)	9.6 (0.89)
CR24	—	2.2 (0.20)	—	7 5/16" (186)	43 1/8" (1095)	7.6 (0.71)	—	6.5 (0.60)	36 11/16" (932)	11.3 (1.05)
CR245	—	2.4 (0.22)	—	7 5/16" (186)	47 15/16" (1218)	8.4 (0.78)	—	7.3 (0.68)	31 7/8" (810)	12.4 (1.15)
CR25	—	2.8 (0.26)	—	7 5/16" (186)	55" (1397)	9.6 (0.89)	—	8.3 (0.77)	24 13/16" (630)	14.2 (1.32)
CR255	—	3.1 (0.29)	—	7 5/16" (186)	59 15/16" (1522)	10.5 (0.98)	—	9.1 (0.85)	19 7/8" (505)	15.4 (1.43)
CR26	—	3.4 (0.32)	—	7 5/16" (186)	67" (1702)	11.7 (1.09)	—	10.2 (0.95)	12 13/16" (325)	17.0 (1.58)
CN12	—	1.5 (0.14)	—	10 13/16" (275)	19 1/4" (489)	2.2 (0.20)	—	1.9 (0.18)	60 9/16" (1538)	3.4 (0.32)
CN125	—	1.8 (0.17)	—	10 13/16" (275)	23 7/16" (595)	2.6 (0.24)	—	2.3 (0.21)	56 3/8" (1432)	4.0 (0.37)
CN13	—	2.3 (0.21)	—	10 13/16" (275)	31 1/16" (789)	3.5 (0.33)	—	3.1 (0.29)	48 3/4" (1238)	5.1 (0.47)
CN135	—	2.7 (0.25)	—	10 13/16" (275)	35 15/16" (913)	4.0 (0.37)	—	3.6 (0.33)	43 7/8" (1114)	5.8 (0.54)
CN14	—	3.2 (0.30)	—	10 13/16" (275)	43 1/8" (1095)	4.8 (0.45)	—	4.3 (0.40)	36 11/16" (932)	6.8 (0.63)
CN145	—	3.6 (0.33)	—	10 13/16" (275)	47 15/16" (1218)	5.4 (0.50)	—	4.8 (0.45)	31 7/8" (810)	7.5 (0.70)
CN15	—	4.1 (0.38)	—	10 13/16" (275)	55" (1397)	6.2 (0.58)	—	5.5 (0.51)	24 13/16" (630)	8.5 (0.79)
CN155	—	4.5 (0.42)	—	10 13/16" (275)	59 15/16" (1522)	6.7 (0.62)	—	6.0 (0.56)	19 7/8" (505)	9.2 (0.86)
CN16	—	5.0 (0.47)	—	10 13/16" (275)	67" (1702)	7.5 (0.70)	—	6.7 (0.62)	12 13/16" (325)	10.2 (0.95)
CN22	—	1.5 (0.14)	—	10 13/16" (275)	19 1/4" (489)	4.4 (0.41)	—	3.8 (0.35)	60 9/16" (1538)	6.8 (0.63)
CN225	—	1.8 (0.17)	—	10 13/16" (275)	23 7/16" (595)	5.2 (0.48)	—	4.6 (0.43)	56 3/8" (1432)	8.0 (0.74)
CN23	—	2.3 (0.21)	—	10 13/16" (275)	31 1/16" (789)	7.0 (0.65)	—	6.2 (0.58)	48 3/4" (1238)	10.2 (0.95)
CN235	—	2.7 (0.25)	—	10 13/16" (275)	35 15/16" (913)	8.0 (0.74)	—	7.2 (0.67)	43 7/8" (1114)	11.5 (1.07)
CN24	—	3.2 (0.30)	—	10 13/16" (275)	43 1/8" (1095)	9.7 (0.90)	—	8.6 (0.80)	36 11/16" (932)	13.6 (1.26)
CN245	—	3.6 (0.33)	—	10 13/16" (275)	47 15/16" (1218)	10.7 (0.99)	—	9.6 (0.89)	31 7/8" (810)	15.0 (1.39)
CN25	—	4.1 (0.38)	—	10 13/16" (275)	55" (1397)	12.3 (1.14)	—	11.0 (1.02)	24 13/16" (630)	16.9 (1.57)
CN255	—	4.5 (0.42)	—	10 13/16" (275)	59 15/16" (1522)	13.4 (1.25)	—	12.0 (1.12)	19 7/8" (505)	18.4 (1.71)
CN26	—	5.0 (0.47)	—	10 13/16" (275)	67" (1702)	15.0 (1.39)	—	13.4 (1.25)	12 13/16" (325)	20.3 (1.89)
CN32	—	1.5 (0.14)	—	10 13/16" (275)	19 1/4" (489)	6.6 (0.61)	—	3.8 (0.35)	60 9/16" (1538)	10.2 (0.95)
CN325	—	1.8 (0.17)	—	10 13/16" (275)	23 7/16" (595)	7.8 (0.73)	—	4.6 (0.43)	56 3/8" (1432)	12.0 (1.12)
CN33	—	2.3 (0.21)	—	10 13/16" (275)	31 1/16" (789)	10.5 (0.98)	—	6.2 (0.58)	48 3/4" (1238)	15.3 (1.42)
CN335	—	2.7 (0.25)	—	10 13/16" (275)	35 15/16" (913)	12.0 (1.12)	—	7.2 (0.67)	43 7/8" (1114)	17.4 (1.62)
CN34	—	3.2 (0.30)	—	10 13/16" (275)	43 1/8" (1095)	14.4 (1.34)	—	8.6 (0.80)	36 11/16" (932)	20.4 (1.90)
CN345	—	3.6 (0.33)	—	10 13/16" (275)	47 15/16" (1218)	16.2 (1.51)	—	9.6 (0.89)	31 7/8" (810)	22.5 (2.09)
CN35	—	4.1 (0.38)	—	10 13/16" (275)	55" (1397)	18.6 (1.73)	—	11.0 (1.02)	24 13/16" (630)	25.5 (2.37)
CN355	—	4.5 (0.42)	—	10 13/16" (275)	59 15/16" (1522)	20.1 (1.87)	—	12.0 (1.11)	19 7/8" (505)	27.6 (2.57)
CN36	—	5.0 (0.47)	—	10 13/16" (275)	67" (1702)	22.5 (2.09)	—	13.4 (1.24)	12 13/16" (325)	30.6 (2.84)
C12	2.5 (0.23)	1.9 (0.18)	18 5/16" (465)	14 7/16" (367)	19 1/4" (489)	2.6 (0.24)	2.5 (0.23)	2.4 (0.22)	60 9/16" (1538)	4.0 (0.37)
C125	3.0 (0.28)	2.4 (0.22)	18 5/16" (465)	14 7/16" (367)	23 7/16" (595)	3.2 (0.30)	3.0 (0.28)	2.9 (0.27)	56 3/8" (1432)	4.7 (0.44)
C13	4.0 (0.37)	3.1 (0.29)	18 5/16" (465)	14 7/16" (367)	31 1/16" (789)	4.3 (0.40)	4.0 (0.37)	3.9 (0.36)	48 3/4" (1238)	6.0 (0.56)
C135	4.6 (0.43)	3.6 (0.33)	18 5/16" (465)	14 7/16" (367)	35 15/16" (913)	4.9 (0.46)	4.6 (0.43)	4.5 (0.42)	43 7/8" (1114)	6.8 (0.63)
C14	5.5 (0.51)	4.3 (0.40)	18 5/16" (465)	14 7/16" (367)	43 1/8" (1095)	5.9 (0.55)	5.5 (0.51)	5.4 (0.50)	36 11/16" (932)	8.0 (0.74)
C145	6.1 (0.57)	4.8 (0.45)	18 5/16" (465)	14 7/16" (367)	47 15/16" (1218)	6.6 (0.61)	6.1 (0.57)	6.0 (0.56)	31 7/8" (810)	8.8 (0.82)
C15	7.0 (0.65)	5.5 (0.51)	18 5/16" (465)	14 7/16" (367)	55" (1397)	7.5 (0.70)	7.0 (0.65)	6.9 (0.64)	24 13/16" (630)	10.0 (0.93)
C155	7.6 (0.71)	6.0 (0.56)	18 5/16" (465)	14 7/16" (367)	59 15/16" (1522)	8.2 (0.76)	7.6 (0.71)	7.5 (0.70)	19 7/8" (505)	10.9 (1.01)
C16	8.5 (0.79)	6.7 (0.62)	18 5/16" (465)	14 7/16" (367)	67" (1702)	9.2 (0.86)	8.5 (0.79)	8.4 (0.78)	12 13/16" (325)	12.0 (1.12)
C22	2.5 (0.23)	1.9 (0.18)	18 5/16" (465)	14 7/16" (367)	19 1/4" (489)	5.2 (0.48)	5.0 (0.46)	4.8 (0.45)	60 9/16" (1538)	8.0 (0.74)
C225	3.0 (0.28)	2.4 (0.22)	18 5/16" (465)	14 7/16" (367)	23 7/16" (595)	6.4 (0.59)	6.0 (0.56)	5.8 (0.54)	56 3/8" (1432)	9.4 (0.87)
C23	4.0 (0.37)	3.1 (0.29)	18 5/16" (465)	14 7/16" (367)	31 1/16" (789)	8.5 (0.79)	7.9 (0.73)	7.8 (0.73)	48 3/4" (1238)	12.0 (1.12)
C235	4.6 (0.43)	3.6 (0.33)	18 5/16" (465)	14 7/16" (367)	35 15/16" (913)	9.9 (0.92)	9.2 (0.86)	9.0 (0.84)	43 7/8" (1114)	13.6 (1.26)
C24	5.5 (0.51)	4.3 (0.40)	18 5/16" (465)	14 7/16" (367)	43 1/8" (1095)	11.8 (1.10)	11.0 (1.02)	10.8 (1.00)	36 11/16" (932)	16.0 (1.49)
C245	6.1 (0.57)	4.8 (0.45)	18 5/16" (465)	14 7/16" (367)	47 15/16" (1218)	13.1 (1.22)	12.2 (1.13)	12.0 (1.12)	31 7/8" (810)	17.6 (1.64)
C25	7.0 (0.65)	5.5 (0.51)	18 5/16" (465)	14 7/16" (367)	55" (1397)	15.1 (1.40)	14.0 (1.30)	13.8 (1.28)	24 13/16" (630)	20.0 (1.86)

\*Top of Subfloor to Top of Inside Sill Stop\* is calculated based upon a structural header height of 6'-10 1/2" (2096).  
• Dimensions in parentheses are in millimeters or square meters.

continued on next page

# CASEMENT & AWNING WINDOWS

## Casement Window Opening and Area Specifications (continued)

Window Number	Clear Opening Area		Clear Opening in Full Open Position			Glass Area Sq. Ft./ (m <sup>2</sup> )	Vent Area		Top of Subfloor to Top of Inside Sill Stop Inches/(mm)	Overall Window Area Sq. Ft./ (m <sup>2</sup> )
	Hinge for Widest Clear Opening Sq. Ft./ (m <sup>2</sup> )	Hinge with Wash Mode Sq. Ft./ (m <sup>2</sup> )	Hinge for Widest Clear Opening Inches/(mm)	Hinge with Wash Mode Inches/(mm)	Height Inches/(mm)		Hinge for Widest Clear Opening Sq. Ft./ (m <sup>2</sup> )	Hinge with Wash Mode Sq. Ft./ (m <sup>2</sup> )		
C255	7.6 (0.71)	6.0 (0.56)	18 5/16" (465)	14 7/16" (367)	59 15/16" (1522)	16.4 (1.52)	15.3 (1.42)	15.0 (1.39)	19 7/8" (505)	21.6 (2.01)
C26	8.5 (0.79)	6.7 (0.62)	18 5/16" (465)	14 7/16" (367)	67" (1702)	18.4 (1.71)	17.1 (1.59)	16.8 (1.56)	12 13/16" (325)	24.0 (2.23)
C32	2.5 (0.23)	1.9 (0.18)	18 5/16" (465)	14 7/16" (367)	19 1/4" (489)	7.8 (0.73)	5.0 (0.46)	4.8 (0.45)	60 3/16" (1538)	12.0 (1.12)
C325	3.0 (0.28)	2.4 (0.22)	18 5/16" (465)	14 7/16" (367)	23 7/16" (595)	9.6 (0.89)	6.0 (0.56)	5.8 (0.54)	56 3/8" (1432)	14.1 (1.31)
C33	4.0 (0.37)	3.1 (0.29)	18 5/16" (465)	14 7/16" (367)	31 1/16" (789)	12.8 (1.19)	7.9 (0.73)	7.8 (0.73)	48 3/4" (1238)	17.9 (1.66)
C335	4.6 (0.43)	3.6 (0.33)	18 5/16" (465)	14 7/16" (367)	35 15/16" (913)	14.8 (1.38)	9.2 (0.86)	9.0 (0.84)	43 7/8" (1114)	20.4 (1.90)
C34	5.5 (0.51)	4.3 (0.40)	18 5/16" (465)	14 7/16" (367)	43 1/8" (1095)	17.7 (1.64)	11.0 (1.02)	10.8 (1.00)	36 11/16" (932)	24.0 (2.23)
C345	6.1 (0.57)	4.8 (0.45)	18 5/16" (465)	14 7/16" (367)	47 15/16" (1218)	19.7 (1.83)	12.2 (1.13)	12.0 (1.12)	31 1/8" (810)	26.4 (2.45)
C35	7.0 (0.65)	5.5 (0.51)	18 5/16" (465)	14 7/16" (367)	55" (1397)	22.6 (2.10)	14.0 (1.30)	13.8 (1.28)	24 13/16" (630)	29.9 (2.78)
CW12*	3.0 (0.28)	2.5 (0.23)	22 9/16" (573)	18 11/16" (475)	19 1/4" (489)	3.2 (0.30)	3.0 (0.28)	3.0 (0.28)	60 9/16" (1538)	4.8 (0.45)
CW125*	3.7 (0.34)	3.0 (0.28)	22 9/16" (573)	18 11/16" (475)	23 7/16" (595)	3.9 (0.36)	3.7 (0.34)	3.6 (0.33)	56 3/8" (1432)	5.6 (0.52)
CW13*	4.9 (0.46)	4.0 (0.37)	22 9/16" (573)	18 11/16" (475)	31 1/16" (789)	5.2 (0.48)	4.9 (0.46)	4.8 (0.45)	48 3/4" (1238)	7.1 (0.66)
CW135 0*	5.7 (0.53)	5.1 (0.47)	22 9/16" (573)	20" (508)	36 3/8" (924)	6.0 (0.56)	5.7 (0.53)	5.5 (0.51)	43 7/8" (1114)	8.0 (0.74)
CW14 0*	6.8 (0.63)	6.0 (0.56)	22 9/16" (573)	20" (508)	43 1/8" (1095)	7.2 (0.67)	6.8 (0.63)	6.6 (0.61)	36 11/16" (932)	9.5 (0.88)
CW145 0*	7.5 (0.70)	6.7 (0.62)	22 9/16" (573)	20" (508)	47 15/16" (1218)	8.0 (0.74)	7.5 (0.70)	7.3 (0.68)	31 1/8" (810)	10.4 (0.97)
CW15 0*	8.6 (0.80)	7.6 (0.71)	22 9/16" (573)	20" (508)	55" (1397)	9.2 (0.86)	8.6 (0.80)	8.4 (0.78)	24 13/16" (630)	11.8 (1.10)
CW155 0*	9.4 (0.87)	8.3 (0.77)	22 9/16" (573)	20" (508)	59 15/16" (1522)	10.0 (0.93)	9.4 (0.87)	9.1 (0.85)	19 7/8" (505)	12.8 (1.19)
CW16 0*	10.5 (0.98)	9.3 (0.86)	22 9/16" (573)	20" (508)	67" (1702)	11.2 (1.04)	10.5 (0.98)	10.2 (0.95)	12 13/16" (325)	14.2 (1.32)
CW22*	3.0 (0.28)	2.5 (0.23)	22 9/16" (573)	18 11/16" (475)	19 1/4" (489)	6.4 (0.59)	6.0 (0.56)	6.0 (0.56)	60 3/8" (1538)	9.6 (0.89)
CW225*	3.7 (0.34)	3.0 (0.28)	22 9/16" (573)	18 11/16" (475)	23 7/16" (595)	7.8 (0.72)	7.4 (0.69)	7.2 (0.67)	56 3/8" (1432)	11.2 (1.04)
CW23*	4.9 (0.46)	4.0 (0.37)	22 9/16" (573)	18 11/16" (475)	31 1/16" (789)	10.4 (0.97)	9.8 (0.91)	9.6 (0.89)	48 3/4" (1238)	14.1 (1.31)
CW235 0*	5.7 (0.53)	5.1 (0.47)	22 9/16" (573)	20" (508)	36 3/8" (924)	12.0 (1.12)	11.4 (1.06)	11.1 (1.03)	43 7/8" (1114)	16.0 (1.49)
CW24 0*	6.8 (0.63)	6.0 (0.56)	22 9/16" (573)	20" (508)	43 1/8" (1095)	14.4 (1.34)	13.5 (1.25)	13.1 (1.22)	36 11/16" (932)	18.8 (1.75)
CW245 0*	7.5 (0.70)	6.7 (0.62)	22 9/16" (573)	20" (508)	47 15/16" (1218)	16.0 (1.49)	15.0 (1.39)	14.6 (1.36)	31 1/8" (810)	20.8 (1.93)
CW25 0*	8.6 (0.80)	7.6 (0.71)	22 9/16" (573)	20" (508)	55" (1397)	18.3 (1.70)	17.3 (1.61)	16.7 (1.55)	24 13/16" (630)	23.5 (2.18)
CW255 0*	9.4 (0.87)	8.3 (0.77)	22 9/16" (573)	20" (508)	59 15/16" (1522)	20.0 (1.86)	18.8 (1.75)	18.2 (1.69)	19 7/8" (505)	25.6 (2.38)
CW26 0*	10.5 (0.98)	9.3 (0.86)	22 9/16" (573)	20" (508)	67" (1702)	22.3 (2.07)	21.0 (1.95)	20.4 (1.90)	12 13/16" (325)	28.2 (2.62)
CW32*	3.0 (0.28)	2.5 (0.23)	22 9/16" (573)	18 11/16" (475)	19 1/4" (489)	9.6 (0.89)	6.0 (0.56)	6.0 (0.56)	60 3/16" (1538)	14.4 (1.34)
CW325*	3.7 (0.34)	3.0 (0.28)	22 9/16" (573)	18 11/16" (475)	23 7/16" (595)	11.7 (1.09)	7.4 (0.69)	7.2 (0.67)	56 3/8" (1432)	16.8 (1.56)
CW33*	4.9 (0.46)	4.0 (0.37)	22 9/16" (567)	18 11/16" (475)	31 1/16" (789)	15.6 (1.45)	9.8 (0.91)	9.6 (0.89)	48 3/4" (1238)	21.1 (1.96)
CW335 0*	5.7 (0.53)	5.1 (0.47)	22 9/16" (567)	20" (508)	36 3/8" (924)	18.0 (1.67)	11.4 (1.06)	11.1 (1.03)	43 7/8" (1114)	24.0 (2.23)
CW34 0*	6.8 (0.63)	6.0 (0.56)	22 9/16" (567)	20" (508)	43 1/8" (1095)	21.6 (2.01)	13.6 (1.26)	13.1 (1.22)	36 11/16" (932)	28.2 (2.62)
CW345 0*	7.5 (0.70)	6.7 (0.62)	22 9/16" (567)	20" (508)	47 15/16" (1218)	24.0 (2.23)	15.0 (1.39)	14.6 (1.36)	31 1/8" (810)	31.0 (2.88)
CW35 0*	8.6 (0.80)	7.6 (0.71)	22 9/16" (567)	20" (508)	55" (1397)	27.6 (2.56)	17.2 (1.60)	16.7 (1.55)	24 13/16" (630)	35.2 (3.27)
CX125	4.2 (0.39)	3.5 (0.33)	25 11/16" (653)	21 13/16" (554)	23 7/16" (595)	4.4 (0.41)	4.2 (0.39)	4.1 (0.38)	56 3/8" (1432)	6.2 (0.58)
CX13	5.5 (0.52)	4.7 (0.44)	25 11/16" (653)	21 13/16" (554)	31 1/16" (789)	5.9 (0.54)	5.5 (0.52)	5.4 (0.51)	48 3/4" (1238)	7.9 (0.73)
CX135 0	6.4 (0.60)	5.4 (0.51)	25 11/16" (653)	21 13/16" (554)	35 15/16" (913)	6.8 (0.63)	6.4 (0.60)	6.3 (0.59)	43 7/8" (1114)	8.9 (0.83)
CX14 0	7.7 (0.72)	6.5 (0.61)	25 11/16" (653)	21 13/16" (554)	43 1/8" (1095)	8.1 (0.76)	7.7 (0.72)	7.6 (0.70)	36 11/16" (932)	10.5 (0.98)
CX145 0	8.6 (0.80)	7.3 (0.67)	25 11/16" (653)	21 13/16" (554)	47 15/16" (1218)	9.0 (0.84)	8.6 (0.80)	8.4 (0.78)	31 1/8" (810)	11.6 (1.07)
CX15 0	9.8 (0.91)	8.3 (0.77)	25 11/16" (653)	21 13/16" (554)	55" (1397)	10.4 (0.96)	9.8 (0.91)	9.7 (0.90)	24 13/16" (630)	13.1 (1.22)
CX155 0	10.7 (0.99)	9.1 (0.84)	25 11/16" (653)	21 13/16" (554)	59 15/16" (1522)	11.3 (1.05)	10.7 (0.99)	10.5 (0.98)	19 7/8" (505)	14.2 (1.32)
CX16 0	12.0 (1.11)	10.1 (0.94)	25 11/16" (653)	21 13/16" (554)	67" (1702)	12.6 (1.17)	12.0 (1.11)	11.8 (1.09)	12 13/16" (325)	15.7 (1.46)
CX23	5.5 (0.52)	4.7 (0.44)	25 11/16" (653)	21 13/16" (554)	31 1/16" (789)	11.7 (1.09)	11.1 (1.03)	10.9 (1.01)	48 3/4" (1238)	15.7 (1.46)
CX235 0	6.4 (0.60)	5.4 (0.51)	25 11/16" (653)	21 13/16" (554)	35 15/16" (913)	13.6 (1.26)	12.8 (1.19)	12.6 (1.17)	43 7/8" (1114)	17.8 (1.65)
CX24 0	7.7 (0.72)	6.5 (0.61)	25 11/16" (653)	21 13/16" (554)	43 1/8" (1095)	16.3 (1.51)	15.4 (1.43)	15.1 (1.41)	36 11/16" (932)	20.9 (1.94)
CX245 0	8.6 (0.80)	7.3 (0.67)	25 11/16" (653)	21 13/16" (554)	47 15/16" (1218)	18.1 (1.68)	17.1 (1.59)	16.8 (1.56)	31 7/8" (810)	23.0 (2.14)
CX25 0	9.8 (0.91)	8.3 (0.77)	25 11/16" (653)	21 13/16" (554)	55" (1397)	20.7 (1.93)	19.6 (1.82)	19.3 (1.79)	24 13/16" (630)	26.1 (2.42)
CXW13 0	6.5 (0.60)	5.6 (0.53)	30 1/8" (765)	26 1/4" (667)	31 1/16" (789)	6.8 (0.63)	6.5 (0.60)	6.1 (0.57)	48 3/4" (1238)	9.0 (0.84)
CXW135 0	7.5 (0.70)	6.6 (0.61)	30 1/8" (765)	26 1/4" (667)	35 15/16" (913)	7.9 (0.73)	7.5 (0.70)	7.0 (0.65)	43 7/8" (1114)	10.2 (0.95)
CXW14 0	9.0 (0.84)	7.9 (0.73)	30 1/8" (765)	26 1/4" (667)	43 1/8" (1095)	9.5 (0.88)	9.0 (0.84)	8.4 (0.78)	36 11/16" (932)	12.0 (1.12)
CXW145 0	10.0 (0.93)	8.8 (0.82)	30 1/8" (765)	26 1/4" (667)	47 15/16" (1218)	10.5 (0.98)	10.0 (0.93)	9.4 (0.87)	31 7/8" (810)	13.2 (1.23)
CXW15 0**	11.5 (1.07)	—	30 1/8" (765)	—	55" (1397)	12.1 (1.12)	11.5 (1.07)	—	24 13/16" (630)	14.9 (1.38)
CXW155 0**	12.6 (1.17)	—	30 1/8" (765)	—	59 15/16" (1522)	13.1 (1.22)	12.6 (1.17)	—	19 7/8" (505)	16.2 (1.51)
CXW16 0**	14.0 (1.30)	—	30 1/8" (765)	—	67" (1702)	14.7 (1.37)	14.0 (1.30)	—	12 13/16" (325)	17.9 (1.66)
CXW23	6.5 (0.60)	5.6 (0.53)	30 1/8" (765)	26 1/4" (667)	31 1/16" (789)	13.6 (1.26)	13.0 (1.21)	12.2 (0.57)	48 3/4" (1238)	17.9 (1.66)
CXW235 0	7.5 (0.70)	6.5 (0.61)	30 1/8" (765)	26 1/4" (667)	35 5/16" (913)	15.8 (1.47)	15.0 (1.39)	14.0 (0.57)	43 7/8" (1114)	20.3 (1.89)
CXW24 0	9.0 (0.84)	7.9 (0.73)	30 1/8" (765)	26 1/4" (667)	43 1/8" (1095)	19.0 (1.77)	18.0 (1.67)	16.8 (0.57)	36 11/16" (932)	23.9 (2.22)
CXW245 0	10.0 (0.93)	8.7 (0.81)	30 1/8" (765)	26 1/4" (667)	47 15/16" (1218)	21.0 (1.95)	20.0 (1.86)	18.8 (0.57)	31 7/8" (810)	26.3 (2.44)
CXW25 0**	11.5 (1.07)	—	30 1/8" (765)	—	55" (1397)	24.2 (2.25)	23.0 (2.14)	—	24 13/16" (630)	29.8 (2.77)

\*Top of Subfloor to Top of Inside Sill Stop" is calculated based upon a structural header height of 6'-10 1/2" (2096).

†Dimensions in parentheses are in millimeters or square meters.

‡Meet or exceed clear opening area of 5.7 sq. ft. or 0.53 m<sup>2</sup>, clear opening width of 20" (508) and clear opening height of 24" (610) with appropriate hinge specified.

§Meet clear opening width of 20" (508) using hinge with wash mode and control bracket (bracket can be pivoted for cleaning position) and meet clear opening width of 22" (559) using hinge for widest clear opening.

\*\*Available with straight-arm operators (hinged for widest clear opening) only.

**Awning Window Opening and Area Specifications**

Window Number	Clear Opening Area Sq. Ft./ (m <sup>2</sup> )	Clear Opening in Full Open Position		Glass Area Sq. Ft./ (m <sup>2</sup> )	Vent Area Sq. Ft./ (m <sup>2</sup> )	Top of Subfloor to Top of Inside Sill Stop Inches/ (mm)	Overall Window Area Sq. Ft./ (m <sup>2</sup> )
		Width Inches/ (mm)	Depth Inches/ (mm)				
AR21	0.9 (0.08)	19 1/2" (495)	6 3/8" (162)	1.7 (0.16)	0.9 (0.08)	67 7/16" (1713)	2.8 (0.26)
AR251	1.1 (0.10)	23 3/4" (603)	6 3/8" (162)	2.0 (0.19)	1.1 (0.10)	67 7/16" (1713)	3.3 (0.31)
AR281	1.2 (0.11)	26 7/8" (683)	6 3/8" (162)	2.3 (0.21)	1.2 (0.11)	67 7/16" (1713)	3.7 (0.34)
AR31	1.4 (0.13)	31 5/16" (795)	6 3/8" (162)	2.7 (0.25)	1.4 (0.13)	67 7/16" (1713)	4.2 (0.39)
AR351	1.6 (0.15)	36 3/16" (919)	6 3/8" (162)	3.1 (0.29)	1.6 (0.15)	67 7/16" (1713)	4.8 (0.45)
AR41	1.9 (0.18)	43 3/8" (1102)	6 3/8" (162)	3.8 (0.35)	1.9 (0.18)	67 7/16" (1713)	5.7 (0.53)
AR451	2.1 (0.20)	48 3/16" (1224)	6 3/8" (162)	4.2 (0.39)	2.1 (0.20)	67 7/16" (1713)	6.2 (0.58)
AR51	2.5 (0.23)	55 1/2" (1410)	6 3/8" (162)	4.8 (0.45)	2.5 (0.23)	67 7/16" (1713)	7.1 (0.66)
AR551	2.7 (0.25)	60 3/16" (1529)	6 3/8" (162)	5.2 (0.48)	2.7 (0.25)	67 7/16" (1713)	7.7 (0.72)
AR61	3.0 (0.28)	67 1/2" (1715)	6 3/8" (162)	5.9 (0.55)	3.0 (0.28)	67 7/16" (1713)	8.5 (0.79)
AR221	0.9 (0.08)	19 1/2" (495)	6 3/8" (162)	3.4 (0.32)	1.7 (0.16)	67 7/16" (1713)	5.6 (0.52)
AR2251	1.1 (0.10)	23 3/4" (603)	6 3/8" (162)	4.0 (0.37)	2.1 (0.20)	67 7/16" (1713)	6.6 (0.61)
AR2281	1.2 (0.11)	26 7/8" (683)	6 3/8" (162)	4.6 (0.43)	2.4 (0.22)	67 7/16" (1713)	7.4 (0.69)
AR231	1.4 (0.13)	31 5/16" (795)	6 3/8" (162)	5.4 (0.50)	2.8 (0.26)	67 7/16" (1713)	8.4 (0.78)
AR321	0.9 (0.08)	19 1/2" (495)	6 3/8" (162)	5.1 (0.47)	2.6 (0.24)	67 7/16" (1713)	8.4 (0.78)
AR3251	1.1 (0.10)	23 3/4" (603)	6 3/8" (162)	6.0 (0.56)	3.2 (0.29)	67 7/16" (1713)	9.9 (0.92)
AN21	0.9 (0.08)	19 1/2" (495)	6 7/16" (164)	2.2 (0.20)	0.9 (0.08)	63 15/16" (1624)	3.4 (0.32)
AN251	1.1 (0.10)	23 3/4" (603)	6 7/16" (164)	2.6 (0.24)	1.1 (0.10)	63 15/16" (1624)	4.0 (0.37)
AN281	1.2 (0.11)	26 7/8" (683)	6 7/16" (164)	3.0 (0.28)	1.2 (0.11)	63 15/16" (1624)	4.5 (0.42)
AN31	1.4 (0.13)	31 5/16" (795)	6 7/16" (164)	3.5 (0.33)	1.4 (0.13)	63 15/16" (1624)	5.1 (0.47)
AN351	1.6 (0.15)	36 3/16" (919)	6 7/16" (164)	4.0 (0.37)	1.6 (0.15)	63 15/16" (1624)	5.8 (0.54)
AN41	1.9 (0.18)	43 3/8" (1102)	6 7/16" (164)	4.8 (0.45)	1.9 (0.18)	63 15/16" (1624)	6.8 (0.63)
AN451	2.2 (0.20)	48 3/16" (1224)	6 7/16" (164)	5.4 (0.50)	2.2 (0.20)	63 15/16" (1624)	7.5 (0.70)
AN51	2.5 (0.23)	55 1/2" (1410)	6 7/16" (164)	6.2 (0.58)	2.5 (0.23)	63 15/16" (1624)	8.5 (0.79)
AN551	2.7 (0.25)	60 3/16" (1529)	6 7/16" (164)	6.7 (0.62)	2.7 (0.25)	63 15/16" (1624)	9.2 (0.86)
AN61	3.0 (0.28)	67 1/2" (1715)	6 7/16" (164)	7.5 (0.70)	3.0 (0.28)	63 15/16" (1624)	10.2 (0.95)
AN221	0.9 (0.08)	19 1/2" (495)	6 7/16" (164)	4.4 (0.41)	1.7 (0.16)	63 15/16" (1624)	6.8 (0.63)
AN2251	1.1 (0.10)	23 3/4" (603)	6 7/16" (164)	5.2 (0.48)	2.1 (0.20)	63 15/16" (1624)	8.0 (0.74)
AN2281	1.2 (0.11)	26 7/8" (683)	6 7/16" (164)	6.0 (0.56)	2.4 (0.22)	63 15/16" (1624)	9.0 (0.84)
AN231	1.4 (0.13)	31 5/16" (795)	6 7/16" (164)	7.0 (0.65)	2.8 (0.26)	63 15/16" (1624)	10.2 (0.95)
AN321	0.9 (0.08)	19 1/2" (495)	6 7/16" (164)	6.6 (0.61)	2.6 (0.24)	63 15/16" (1624)	10.2 (0.95)
AN3251	1.1 (0.10)	23 3/4" (603)	6 7/16" (164)	7.8 (0.73)	3.2 (0.30)	63 15/16" (1624)	12.0 (1.12)
A21	0.9 (0.08)	19 1/2" (495)	6 1/2" (165)	2.6 (0.24)	0.9 (0.08)	60 5/16" (1532)	4.0 (0.37)
A251	1.1 (0.10)	23 3/4" (603)	6 1/2" (165)	3.2 (0.30)	1.1 (0.10)	60 5/16" (1532)	4.8 (0.45)
A281	1.2 (0.11)	26 7/8" (683)	6 1/2" (165)	3.7 (0.34)	1.2 (0.11)	60 5/16" (1532)	5.3 (0.49)
A31	1.4 (0.13)	31 5/16" (795)	6 1/2" (165)	4.3 (0.40)	1.4 (0.13)	60 5/16" (1532)	6.0 (0.56)
A351	1.6 (0.15)	36 3/16" (919)	6 1/2" (165)	4.9 (0.46)	1.6 (0.15)	60 5/16" (1532)	6.8 (0.63)
A41	2.0 (0.18)	43 3/8" (1102)	6 1/2" (165)	5.9 (0.55)	2.0 (0.18)	60 5/16" (1532)	8.0 (0.74)
A451	2.2 (0.20)	48 3/16" (1224)	6 1/2" (165)	6.6 (0.61)	2.2 (0.20)	60 5/16" (1532)	8.8 (0.82)
A51	2.5 (0.23)	55 1/2" (1410)	6 1/2" (165)	7.5 (0.70)	2.5 (0.23)	60 5/16" (1532)	10.0 (0.93)
A551	2.7 (0.25)	60 3/16" (1529)	6 1/2" (165)	8.2 (0.76)	2.7 (0.25)	60 5/16" (1532)	10.9 (1.01)
A61	3.0 (0.28)	67 1/2" (1715)	6 1/2" (165)	9.2 (0.86)	3.0 (0.28)	60 5/16" (1532)	12.0 (1.12)
A221	0.9 (0.08)	19 1/2" (495)	6 1/2" (165)	5.2 (0.48)	1.8 (0.16)	60 5/16" (1532)	8.0 (0.74)
A2251	1.1 (0.10)	23 3/4" (603)	6 1/2" (165)	6.4 (0.60)	2.1 (0.20)	60 5/16" (1532)	9.6 (0.89)
A2281	1.2 (0.11)	26 7/8" (683)	6 1/2" (165)	7.4 (0.69)	2.4 (0.23)	60 5/16" (1532)	10.6 (0.99)
A231	1.4 (0.13)	31 5/16" (795)	6 1/2" (165)	8.6 (0.80)	2.8 (0.26)	60 5/16" (1532)	12.0 (1.12)
A321	0.9 (0.08)	19 1/2" (495)	6 1/2" (165)	7.8 (0.73)	2.6 (0.25)	60 5/16" (1532)	12.0 (1.12)
A3251	1.1 (0.10)	23 3/4" (603)	6 1/2" (165)	9.6 (0.89)	3.2 (0.30)	60 5/16" (1532)	14.4 (1.34)
AW21	0.9 (0.08)	19 1/2" (495)	6 1/2" (165)	3.2 (0.30)	0.9 (0.08)	56 1/16" (1424)	4.8 (0.45)
AW251	1.1 (0.10)	23 3/4" (603)	6 1/2" (165)	3.9 (0.36)	1.1 (0.10)	56 1/16" (1424)	5.6 (0.52)
AW281	1.2 (0.11)	26 7/8" (683)	6 1/2" (165)	4.4 (0.41)	1.2 (0.11)	56 1/16" (1424)	6.2 (0.58)
AW31	1.4 (0.13)	31 5/16" (795)	6 1/2" (165)	5.2 (0.48)	1.4 (0.13)	56 1/16" (1424)	7.1 (0.66)
AW351	1.6 (0.15)	36 3/16" (919)	6 1/2" (165)	6.0 (0.56)	1.6 (0.15)	56 1/16" (1424)	8.0 (0.74)
AW41	2.0 (0.18)	43 3/8" (1102)	6 1/2" (165)	7.2 (0.67)	2.0 (0.18)	56 1/16" (1424)	9.5 (0.88)
AW451	2.2 (0.20)	48 3/16" (1224)	6 1/2" (165)	8.0 (0.74)	2.2 (0.20)	56 1/16" (1424)	10.4 (0.97)
AW51	2.5 (0.23)	55 1/2" (1410)	6 1/2" (165)	9.2 (0.86)	2.5 (0.23)	56 1/16" (1424)	11.8 (1.10)
AW551	2.7 (0.25)	60 3/16" (1529)	6 1/2" (165)	10.0 (0.93)	2.7 (0.25)	56 1/16" (1424)	12.8 (1.19)
AW61	3.0 (0.28)	67 1/2" (1715)	6 1/2" (165)	11.2 (1.04)	3.0 (0.28)	56 1/16" (1424)	14.2 (1.32)
AW221	0.9 (0.08)	19 1/2" (495)	6 1/2" (165)	6.4 (0.60)	1.8 (0.16)	56 1/16" (1424)	9.6 (0.89)
AW2251	1.1 (0.10)	23 3/4" (603)	6 1/2" (165)	7.8 (0.73)	2.1 (0.20)	56 1/16" (1424)	11.2 (1.04)

\* Top of Subfloor to Top of Inside Sill Stop is calculated based upon a structural header height of 6'-10 1/2" (2096).  
 • Dimensions in parentheses are in millimeters or square meters.

continued on next page

**Picture Window Area Specifications**

Window Number	Glass Area Sq. Ft./ (m <sup>2</sup> )	Overall Window Area Sq. Ft./ (m <sup>2</sup> )
P3030	6.8 (0.63)	9.0 (0.84)
P3035	7.8 (0.73)	10.2 (0.95)
P3040	9.4 (0.87)	12.0 (1.12)
P3045	10.4 (0.97)	13.2 (1.23)
P3050	12.0 (1.12)	14.9 (1.38)
P3055	13.0 (1.21)	16.2 (1.51)
P3060	14.6 (1.36)	17.9 (1.66)
P3530	7.8 (0.73)	10.2 (0.95)
P3535	9.0 (0.84)	11.6 (1.08)
P3540	10.8 (1.00)	13.6 (1.26)
P3545	12.1 (1.12)	15.0 (1.39)
P3550	13.8 (1.28)	17.0 (1.58)
P3555	15.1 (1.40)	18.4 (1.71)
P3560	16.8 (1.56)	20.4 (1.90)
P4030	9.4 (0.87)	12.0 (1.12)
P4035	10.8 (1.00)	13.6 (1.26)
P4040	13.0 (1.21)	16.0 (1.49)
P4045	14.5 (1.35)	17.6 (1.64)
P4050	16.6 (1.54)	20.0 (1.86)
P4055	18.1 (1.68)	21.6 (2.01)
P4060	20.2 (1.88)	24.0 (2.23)
P4530	10.4 (0.97)	13.2 (1.23)
P4535	12.1 (1.12)	15.0 (1.39)
P4540	14.5 (1.35)	17.6 (1.64)
P4545	16.1 (1.50)	19.4 (1.80)
P4550	18.4 (1.71)	22.0 (2.04)
P4555	20.1 (1.87)	23.8 (2.21)
P4560	22.4 (2.08)	26.4 (2.45)
P5030	12.0 (1.12)	14.9 (1.38)
P5035	13.8 (1.28)	17.0 (1.58)
P5040	16.6 (1.54)	20.0 (1.86)
P5045	18.4 (1.71)	22.0 (2.04)
P5050	21.1 (1.96)	24.9 (2.31)
P5055	23.0 (2.14)	26.9 (2.50)
P5060	25.7 (2.39)	29.9 (2.78)
P5530	13.0 (1.21)	16.2 (1.51)
P5535	15.1 (1.40)	18.4 (1.71)
P5540	18.1 (1.68)	21.6 (2.01)
P5545	20.1 (1.87)	23.8 (2.21)
P5550	23.0 (2.14)	26.9 (2.50)
P6030	14.6 (1.36)	17.9 (1.66)
P6035	16.8 (1.56)	20.4 (1.90)
P6040	20.2 (1.88)	24.0 (2.23)
P6045	22.4 (2.08)	26.4 (2.45)
P6050	25.7 (2.39)	29.9 (2.78)

\* Dimensions in parentheses are in square meters.

# CASEMENT & AWNING WINDOWS

## Awning Window Opening and Area Specifications *(continued)*

Window Number	Clear Opening Area Sq. Ft./ (m <sup>2</sup> )	Clear Opening in Full Open Position		Glass Area Sq. Ft./ (m <sup>2</sup> )	Vent Area Sq. Ft./ (m <sup>2</sup> )	Top of Subfloor to Top of Inside Sill Stop Inches/(mm)	Overall Window Area Sq. Ft./ (m <sup>2</sup> )
		Width Inches/(mm)	Depth Inches/(mm)				
AW2281	1.2 (0.11)	26 7/8" (683)	6 1/2" (165)	8.8 (0.82)	2.4 (0.23)	56 1/16" (1424)	12.4 (1.15)
AW231	1.4 (0.13)	31 5/16" (795)	6 1/2" (165)	10.4 (0.97)	2.8 (0.26)	56 1/16" (1424)	14.2 (1.32)
AW321	0.9 (0.08)	19 1/2" (495)	6 1/2" (165)	9.6 (0.89)	2.6 (0.25)	56 1/16" (1424)	14.4 (1.34)
AW3251	1.1 (0.10)	23 3/4" (603)	6 1/2" (165)	11.7 (1.09)	3.2 (0.30)	56 1/16" (1424)	16.8 (1.56)
AX251	1.1 (0.10)	23 3/4" (603)	6 1/2" (165)	4.4 (0.41)	1.1 (0.10)	53 15/16" (1370)	6.2 (0.58)
AX281	1.2 (0.11)	26 7/8" (683)	6 1/2" (165)	5.0 (0.47)	1.2 (0.11)	53 15/16" (1370)	6.9 (0.64)
AX31	1.4 (0.13)	31 5/16" (795)	6 1/2" (165)	5.9 (0.54)	1.4 (0.13)	53 15/16" (1370)	7.9 (0.73)
AX351	1.6 (0.15)	36 3/16" (919)	6 1/2" (165)	6.8 (0.63)	1.6 (0.15)	53 15/16" (1370)	8.9 (0.83)
AX41	2.0 (0.18)	43 3/8" (1102)	6 1/2" (165)	8.1 (0.76)	2.0 (0.18)	53 15/16" (1370)	10.5 (0.98)
AX451	2.2 (0.20)	48 3/16" (1224)	6 1/2" (165)	9.0 (0.84)	2.2 (0.20)	53 15/16" (1370)	11.6 (1.07)
AX51	2.5 (0.23)	55 1/2" (1410)	6 1/2" (165)	10.4 (0.96)	2.5 (0.23)	53 15/16" (1370)	13.1 (1.22)
AX551	2.7 (0.25)	60 3/16" (1529)	6 1/2" (165)	11.3 (1.05)	2.7 (0.25)	53 15/16" (1370)	14.2 (1.32)
AX61	3.0 (0.28)	67 1/2" (1715)	6 1/2" (165)	12.6 (1.17)	3.0 (0.28)	53 15/16" (1370)	15.7 (1.46)
AX2251	1.1 (0.10)	23 3/4" (603)	6 1/2" (165)	8.9 (0.82)	2.1 (0.20)	53 15/16" (1370)	12.4 (1.15)
AX2281	1.2 (0.11)	26 7/8" (683)	6 1/2" (165)	10.0 (0.93)	2.4 (0.23)	53 15/16" (1370)	13.8 (1.28)
AX231	1.4 (0.13)	31 5/16" (795)	6 1/2" (165)	11.7 (1.09)	2.8 (0.26)	53 15/16" (1370)	15.7 (1.46)
AX3251	1.1 (0.10)	23 3/4" (603)	6 1/2" (165)	13.3 (1.24)	3.2 (0.30)	53 15/16" (1370)	18.6 (1.73)
AXW281	1.2 (0.11)	26 7/8" (683)	6 1/2" (165)	5.8 (0.54)	1.2 (0.11)	48 1/2" (1232)	7.9 (0.73)
AXW31	1.4 (0.13)	31 5/16" (795)	6 1/2" (165)	6.8 (0.63)	1.4 (0.13)	48 1/2" (1232)	9.0 (0.84)
AXW351	1.6 (0.15)	36 3/16" (919)	6 1/2" (165)	7.9 (0.73)	1.6 (0.15)	48 1/2" (1232)	10.2 (0.95)
AXW41	2.0 (0.18)	43 3/8" (1102)	6 1/2" (165)	9.5 (0.88)	2.0 (0.18)	48 1/2" (1232)	12.0 (1.12)
AXW451	2.2 (0.20)	48 3/16" (1224)	6 1/2" (165)	10.5 (0.98)	2.2 (0.20)	48 1/2" (1232)	13.2 (1.23)
AXW51	2.5 (0.23)	55 1/2" (1410)	6 1/2" (165)	12.1 (1.12)	2.5 (0.23)	48 1/2" (1232)	14.9 (1.38)
AXW551	2.7 (0.25)	60 3/16" (1529)	6 1/2" (165)	13.1 (1.22)	2.7 (0.25)	48 1/2" (1232)	16.2 (1.51)
AXW61	3.0 (0.28)	67 1/2" (1715)	6 1/2" (165)	14.7 (1.37)	3.0 (0.28)	48 1/2" (1232)	17.9 (1.66)
AXW2281	1.2 (0.11)	26 7/8" (683)	6 1/2" (165)	11.6 (1.08)	2.4 (0.23)	48 1/2" (1232)	15.8 (1.47)
AXW231	1.4 (0.13)	31 5/16" (795)	6 1/2" (165)	13.6 (1.26)	2.8 (0.26)	48 1/2" (1232)	18.0 (1.67)
A335*	1.4 (0.13)	31 5/16" (795)	6 1/2" (676)	7.0 (0.65)	1.3 (0.12)	43 11/16" (1110)	10.2 (0.95)
A3535	1.6 (0.14)	36 3/16" (943)	6 1/2" (165)	8.1 (0.75)	1.6 (0.15)	43 11/16" (1110)	11.5 (1.07)
AP32V	1.4 (0.12)	31 5/16" (795)	6 1/2" (165)	9.4 (0.87)	1.4 (0.13)	36 7/16" (926)	12.0 (1.12)
AP352V	1.6 (0.14)	36 3/16" (919)	6 1/2" (165)	10.9 (1.01)	1.6 (0.15)	36 7/16" (926)	13.6 (1.26)
AP42V	2.0 (0.17)	43 3/8" (1102)	6 1/2" (165)	13.1 (1.22)	2.0 (0.18)	36 7/16" (926)	16.0 (1.49)
A212	0.9 (0.08)	19 1/2" (495)	6 1/2" (165)	5.2 (0.48)	1.8 (0.16)	60 5/16" (1532)	8.0 (0.74)
A213	0.9 (0.08)	19 1/2" (495)	6 1/2" (165)	7.8 (0.73)	2.6 (0.25)	60 5/16" (1532)	12.0 (1.12)
A312	1.4 (0.13)	31 5/16" (795)	6 1/2" (165)	8.6 (0.80)	2.8 (0.26)	60 5/16" (1532)	12.0 (1.12)
A313	1.4 (0.13)	31 5/16" (795)	6 1/2" (165)	12.9 (1.20)	4.2 (0.39)	60 5/16" (1532)	18.0 (1.67)
PA3050**	1.4 (0.13)	31 5/16" (795)	6 1/2" (165)	4.3 (0.40)	1.4 (0.13)	60 5/16" (1532)	6.0 (0.56)
PA3060**	1.4 (0.13)	31 5/16" (795)	6 1/2" (165)	4.3 (0.40)	1.4 (0.13)	60 5/16" (1532)	6.0 (0.56)
PA3550**	1.6 (0.15)	36 3/16" (919)	6 1/2" (165)	4.9 (0.46)	1.6 (0.15)	60 5/16" (1532)	6.8 (0.63)
PA3560**	1.6 (0.15)	36 3/16" (919)	6 1/2" (165)	4.9 (0.46)	1.6 (0.15)	60 5/16" (1532)	6.8 (0.63)
PA4060**	2.0 (0.18)	43 3/8" (1102)	6 1/2" (165)	5.9 (0.55)	2.0 (0.18)	60 5/16" (1532)	8.0 (0.74)
AXW312	1.4 (0.13)	31 1/3" (795)	6 1/2" (165)	13.6 (1.26)	2.8 (0.26)	48 1/2" (1232)	18.0 (1.67)

\*"Top of Subfloor to Top of Inside Sill Stop" is calculated based upon a structural header height of 6'-10 1/2" (2096).

\*Dimensions in parentheses are in millimeters or square meters.

\*Clear opening area of 5.8 sq. ft. or 0.54 m<sup>2</sup> and clear opening height of 26 1/2" (673) can be obtained by detaching operator from sash.

\*\*Dimensions and calculations are for bottom venting sash.

## Transom Window Area Specifications

Window Number	Glass Area Sq. Ft./ (m <sup>2</sup> )	Overall Window Area Sq. Ft./ (m <sup>2</sup> )
CTR1510	0.7 (0.07)	1.4 (0.13)
CTR1810	0.8 (0.07)	1.7 (0.16)
CTR21810	1.7 (0.16)	3.4 (0.32)
CTR31810	2.6 (0.24)	5.1 (0.47)
CTR2010	1.0 (0.09)	2.0 (0.19)
CTR22010	2.1 (0.19)	4.0 (0.37)
CTR32010	3.1 (0.29)	6.0 (0.56)
CTR2410	1.2 (0.11)	2.4 (0.22)
CTR22410	2.5 (0.24)	4.7 (0.44)
CTR32410	3.8 (0.35)	7.1 (0.66)
CTR2810	1.4 (0.13)	2.6 (0.24)
CTR22810	2.9 (0.27)	5.2 (0.49)
CTR3010	1.6 (0.15)	3.0 (0.28)
CTR23010	3.3 (0.31)	6.0 (0.55)
CTR5110	2.8 (0.26)	5.1 (0.47)
CTR2910	1.5 (0.14)	2.8 (0.26)
CTR3410	1.8 (0.17)	3.4 (0.32)
CTR4010	2.2 (0.20)	4.0 (0.37)
CTR4810	2.6 (0.24)	4.7 (0.44)
CTR5210	2.9 (0.27)	5.2 (0.48)
CTR51110	3.4 (0.32)	6.0 (0.56)
CTR6010	3.4 (0.32)	6.0 (0.56)
CTR7010	4.0 (0.37)	7.1 (0.66)
PTR3010	1.6 (0.15)	3.0 (0.28)
PTR3510	1.8 (0.17)	3.4 (0.32)
PTR4010	2.2 (0.20)	4.0 (0.37)
PTR4510	2.4 (0.22)	4.4 (0.41)
PTR5010	2.8 (0.26)	5.0 (0.47)
PTR5510	3.0 (0.28)	5.4 (0.50)
PTR6010	3.4 (0.32)	6.0 (0.56)

\*Dimensions in parentheses are in square meters.

**Custom Sizes and Specification Formulas**

**Casement Windows (stationary & venting)**

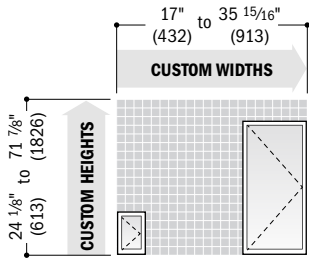

Available in 1/8" (3) increments between minimum and maximum widths and heights. Windows can also be custom sized to match standard sizes ending in a sixteenth of an inch. Some restrictions apply, contact your Andersen supplier. Custom sizing is available for single windows only. To achieve custom-size 2- or 3-wide combinations, join custom-size single windows. For minimum rough opening dimensions for joined windows, see specific joining instruction guides. Measurement guide for custom-size windows can be found at [andersenwindows.com/measure](http://andersenwindows.com/measure).

 <b>Clear Opg.</b>	Width = window width - 5.81" (148) = (window width - 9.66" (245)) X 1.07 = window width - 9.70" (246)  Height = window height - 4.43" (113) = window height - 4.85" (123)	Width ≥ 24 1/8" (613) (hinge for widest clear opening) Width ≥ 28 3/8" (721) (hinge with wash mode & control bracket) Width ≥ 17" (432) (hinge with wash mode)  Height ≥ 40 13/16" (1037) and < 48" (1219); Width ≥ 28 3/8" (721) and < 31 1/2" (800) All other window heights	 <b>Min. R.O.</b>	Width = window width + 1/2" (13)  Height = window height + 1/2" (13)
	 <b>Vent Opg.</b>	Width = window width - 5.81" (148) = window width - 6.10" (155)  Height = window height - 4.43" (113) = window height - 4.85" (123)		Width ≥ 24 1/8" (613) (hinge for widest clear opening) Width ≥ 17" (432) (hinge with wash mode)  Height ≥ 40 13/16" (1037) and < 48" (1219); Width ≥ 28 3/8" (721) and < 31 1/2" (800) All other window heights

**Awning Windows (stationary & venting)**

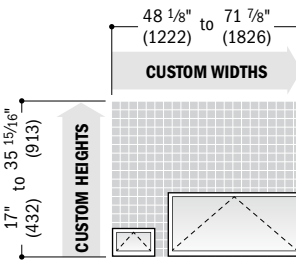
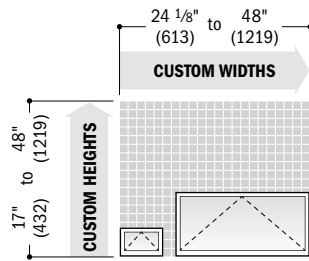
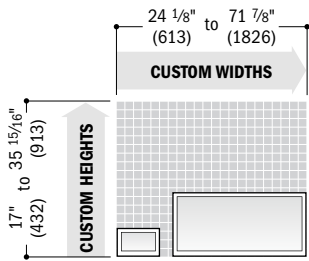

 <b>Clear Opg.</b>	Width = window width - 4.53" (115)  Depth = 6.38" (162) = 6.44" (164) = 6.50" (165)	Height ≥ 17" (432) and < 20 1/2" (521) Height ≥ 20 1/2" (521) and < 24 1/8" (613) All other window heights	 <b>Min. R.O.</b>	Width = window width + 1/2" (13)  Height = window height + 1/2" (13)
	 <b>Vent Opg.</b>	Width = window width - 4.53" (115)  Depth = 6.38" (162) = 6.44" (164) = 6.50" (165)		Height ≥ 17" (432) and < 20 1/2" (521) Height ≥ 20 1/2" (521) and < 24 1/8" (613) All other window heights

**Casement/Awning Picture and Transom Windows**

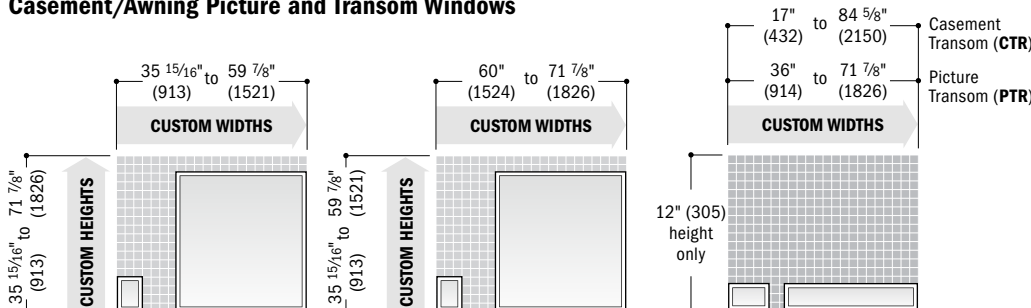

 <b>Min. R.O.</b>	Width = window width - 1/2" (13)  Height = window height - 1/2" (13)
	 <b>Unobst. Gls.</b>

• Dimensions in parentheses are in millimeters.  
 • **Clear Opg.** (clear opening) formulas provide dimensions for determining area available for egress. **Vent Opg.** (vent opening) formulas provide dimensions for determining area available for passage of air. **Min. R.O.** (minimum rough opening) formulas provide minimum rough opening width and height dimensions. **Unobst. Gls.** (unobstructed glass) formulas provide dimensions for determining area available for passage of light.  
 • Refer to [andersenwindows.com/measure](http://andersenwindows.com/measure) for detailed instructions on how to properly measure for custom-size windows.

# CASEMENT & AWNING WINDOWS

## Grille Patterns

	Diamond*	Prairie A	Specified Equal Light with Simulated Meeting Rail	Colonial	Modified Colonial	Modified Colonial with Simulated Meeting Rail	Tall Fractional	Tall Fractional with Simulated Meeting Rail	Short Fractional	Short Fractional with Simulated Meeting Rail	Victorian
<b>Casement</b>											
<b>Awning</b>											
<b>Picture</b>											
<b>Transom</b>											

\*Available only in Simulated Divided Light (SDL) configuration and only in 3/4" (19) and 7/8" (22) widths.

### Number of lights and overall pattern varies with window size.

Patterns are not available in all configurations. Specified equal light and custom patterns are also available. For more grille options, see page 13 or visit [andersenwindows.com/grilles](http://andersenwindows.com/grilles).

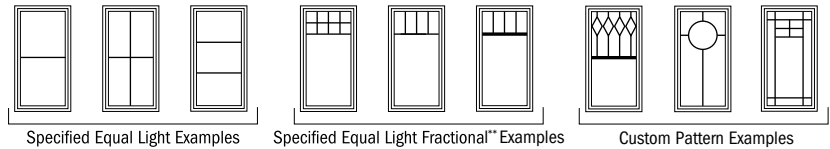

\*\*Daylight opening dimensions are available at 8" (203), 10" (254), 12" (305), center and custom dimensions.

## Interior Trim Options

Extension jamb and drywall return bead applications shown. See page 21 for more information.

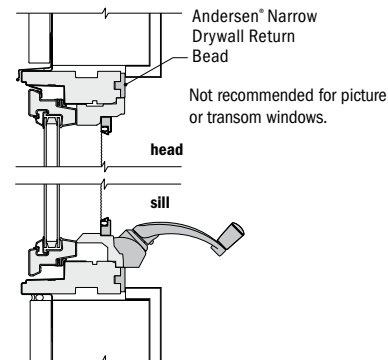
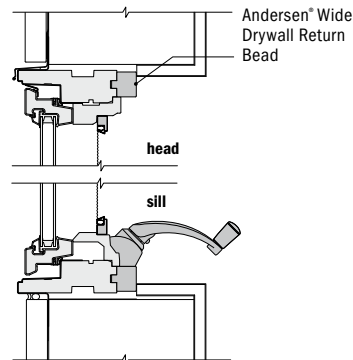
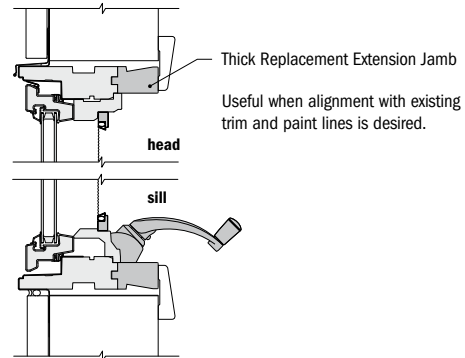
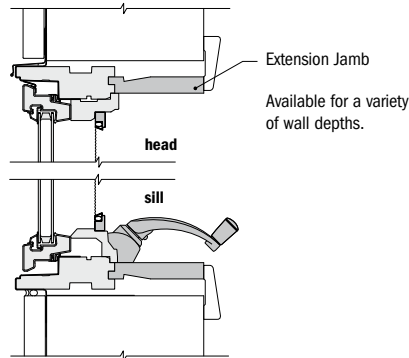

\* Light-colored areas are parts included with window. Dark-colored areas are additional Andersen® parts required to complete window assembly as shown.

• Dimensions in parentheses are in millimeters.

• Details are for illustration only and are not intended to represent product installation methods or materials. Refer to product installation guides at [andersenwindows.com](http://andersenwindows.com).

**Casement Window Details**

Scale 1 1/2" (38) = 1'-0" (305) – 1:8

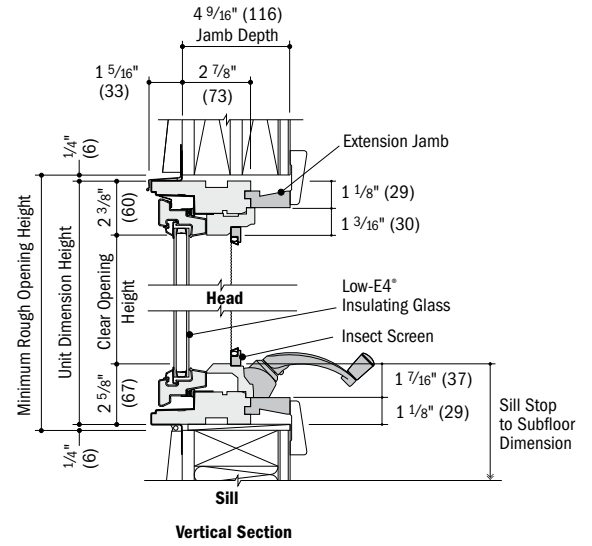
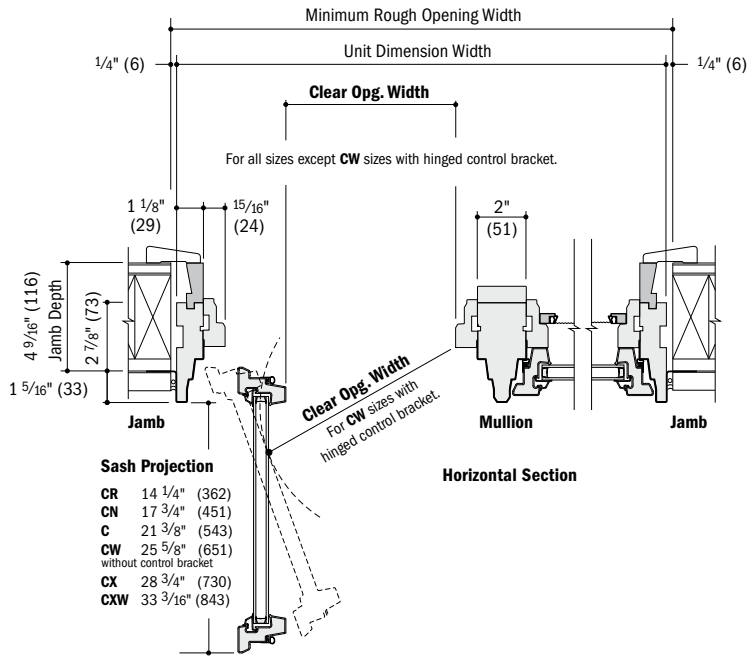

**Awning Window Details**

Scale 1 1/2" (38) = 1'-0" (305) – 1:8

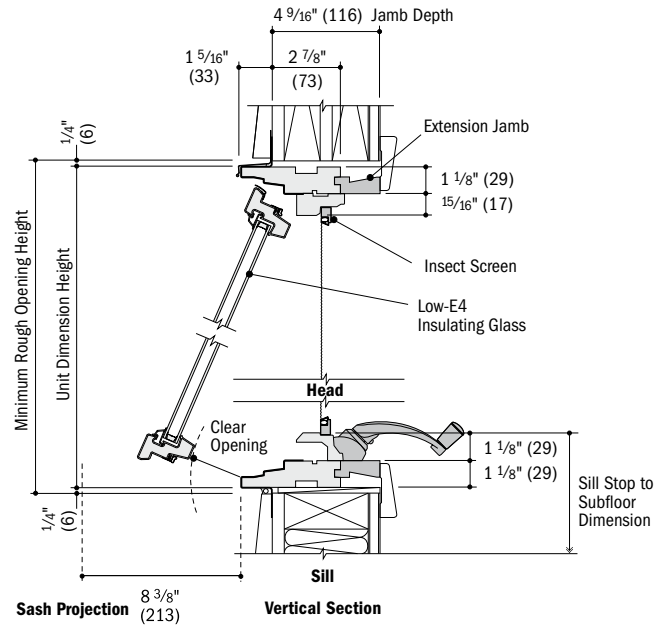
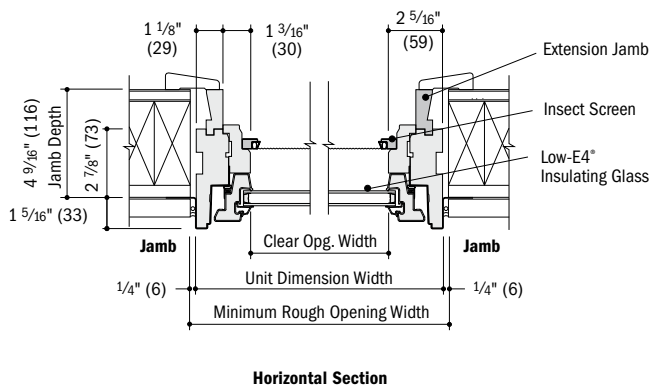

- 4 9/16" (116) jamb depth measurement is from back side of installation flange.
- Light-colored areas are parts included with window. Dark-colored areas are additional Andersen® parts required to complete window assembly as shown.
- Dimensions in parentheses are in millimeters.
- Rough openings may need to be increased to allow for use of building wraps, flashing, sill panning, brackets, fasteners or other items. See installation information on pages 210-211.
- Details are for illustration only and are not intended to represent product installation methods or materials. Refer to product installation guides at andersenwindows.com.

# CASEMENT & AWNING WINDOWS

## Picture and Transom Window Details

Scale 1 1/2" (38) = 1'-0" (305) – 1:8

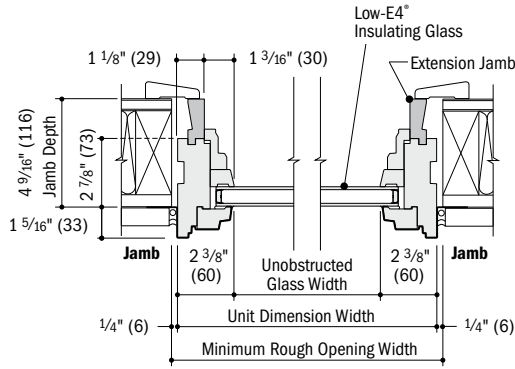

Horizontal Section

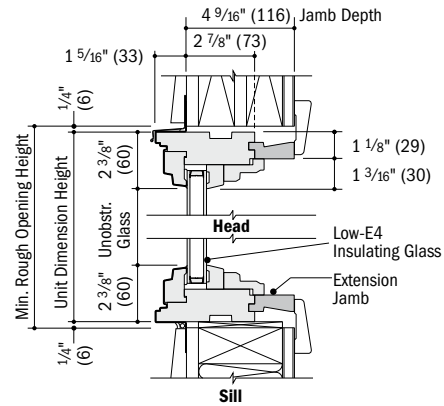

Vertical Section

## Horizontal (stack) Joining Detail

Scale 1 1/2" (38) = 1'-0" (305) – 1:8

### Overall Window Dimension Height

Sum of individual window heights plus 1/8" (3) for each join.

### Overall Rough Opening Height

Overall window dimension height plus 1/2" (13).

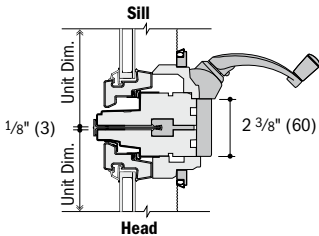

Vertical Section  
Casement over Awning

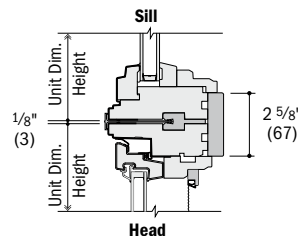

Vertical Section  
Picture over Casement

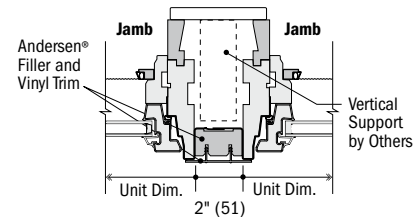

Horizontal Section  
Casement and Casement

## Vertical (ribbon) Joining Detail

Scale 1 1/2" (38) = 1'-0" (305) – 1:8

### Overall Window Dimension Width

Sum of individual window widths plus 1/8" (3) for each join.

### Overall Rough Opening Width

Overall window dimension width plus 1/2" (13).

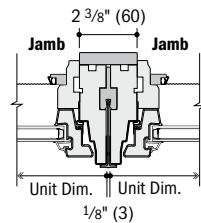

Horizontal Section  
Casement to Casement

For more joining information, see the combination designs section starting on page 181.

- 4 9/16" (116) jamb depth measurement is from back side of installation flange.
- Light-colored areas are parts included with window. Dark-colored areas are additional Andersen® parts required to complete window assembly as shown.
- Dimensions in parentheses are in millimeters.
- Rough openings may need to be increased to allow for use of building wraps, flashing, sill panning, brackets, fasteners or other items. See installation information on pages 210-211.
- Details are for illustration only and are not intended to represent product installation methods or materials. Refer to product installation guides at andersenwindows.com.
- Consult with an architect or structural engineer regarding minimum requirements for structural support members between adjacent rough openings.

# REPLACEMENT CASEMENT & AWNING WINDOWS

400 Series  
Replacement Casement  
& Awning Windows



## SECTION REFERENCE

Custom Sizing .....	40
Grille Patterns .....	34
Window Details .....	35-36
Product Performance.....	194

**CUSTOM SIZING**  
in 1/8" (3) increments



Dimensions in parentheses are in millimeters.

# REPLACEMENT CASEMENT & AWNING WINDOWS

## FEATURES

### Frame

**A** A seamless one-piece, rigid vinyl frame cover is secured to the exterior of the frame to protect the wood frame from moisture and maintain an attractive appearance while minimizing maintenance.

**B** Pre-drilled, through-the-jamb installation holes allow for quick and easy installation.

**C** Wood frame members are treated with a water-repellent preservative for long-lasting\* protection and performance.

**D** Interior stops are unfinished pine. Low-maintenance prefinished white, dark bronze and black interiors are also available.

### Sash

**E** Rigid vinyl encases the entire sash — a vinyl weld protects each sash corner for superior weathertightness. It maintains an attractive appearance and minimizes maintenance.

**F** Wood core members provide excellent structural stability and energy efficiency.

**G** Flexible bulb weatherstrip or vinyl closed-cell foam weatherstrip is factory installed on the perimeter of the sash.

### Hardware

#### Smooth Control Hardware System



The smooth control hardware system employs a worm gear drive for easy operation. Units with a wash mode have hinges that move the sash away from the frame to

provide easier glass cleaning. **CXW15**, **CXW155**, **CXW16** and **CXW25** sizes are not available with wash mode. Hardware option and finish must be specified. Operator handle and cover sold separately.



#### Single-Actuation Casement Lock

On casement windows, a single-actuation lock easily releases all locking points on casement sash while the reach-out action eliminates binding when

closing. The lock handle is offered in finishes that coordinate with your specified hardware option.

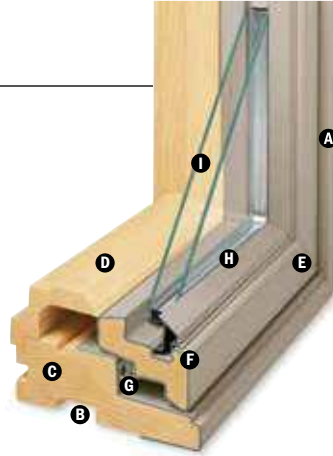

#### Awning Sash Locks



Awning sash locks provide an added measure of security and weathertightness. Hardware style and finish options are compatible with Andersen® casement windows to ensure consistency in appearance when used in combination designs.

### Glass

**H** A glazing bead and silicone provide superior weathertightness and durability.

**I** High-Performance glass options include:

- Low-E4® glass
- Low-E4 HeatLock® glass
- Low-E4 Sun glass
- Low-E4 SmartSun™ glass
- Low-E4 SmartSun HeatLock glass

Tempered glass and other glass options are available. Contact your Andersen supplier.

A removable translucent film helps shield the glass from damage during delivery and construction and simplifies finishing at the jobsite.

#### Patterned Glass

Patterned glass options are available. See page 12 for more details.

#### Included Installation Materials



Flat, self-hanging shims, backer rod, installation screws and complete instructions are included with each replacement casement window. Measurement guide and worksheet at [andersenwindows.com/measure](http://andersenwindows.com/measure).

## EXTERIOR



## INTERIOR

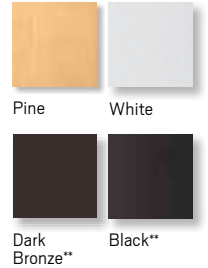

Naturally occurring variations in grain, color and texture of wood make each window one of a kind. All wood interiors are unfinished unless a prefinished option is specified.

## HARDWARE FINISHES



Distressed bronze and oil rubbed bronze are "living" finishes that will change with time and use.

## CASEMENT & AWNING HARDWARE OPTIONS†

### CLASSIC SERIES™



Stone | White

### ESTATE™



**Antique Brass** | Bright Brass  
Brushed Chrome | Distressed Bronze  
Distressed Nickel | Oil Rubbed Bronze  
Polished Chrome | Satin Nickel

### TRADITIONAL FOLDING



Antique Brass | Black | Bright Brass  
**Distressed Bronze** | Distressed Nickel  
Gold Dust | Oil Rubbed Bronze | Satin Nickel  
Stone | White

### CONTEMPORARY FOLDING



Black | Bright Brass  
Gold Dust | Oil Rubbed Bronze  
**Satin Nickel** | Stone | White

Folding handle avoids interference with window decorating treatments. Bold name denotes finish shown.

\* Visit [andersenwindows.com/warranty](http://andersenwindows.com/warranty) for details.

\*\* Dark bronze and black interiors are only available with dark bronze and black exteriors respectively.

† Hardware sold separately.

Printing limitations prevent exact replication of colors and finishes. See your Andersen supplier for actual color and finish samples.

**ACCESSORIES** Sold Separately

**Frame**

**Extension Jambs**



Standard jamb depth is 2 7/8" (73). Extension jambs are available in unfinished pine or prefinished white. Some sizes may be veneered.

Factory-applied and non-applied interior extension jambs are available in 1/16" (1.5) increments between 4 9/16" (116) and 7 1/8" (181). Extension jambs can be factory applied to either three sides (stool and apron application) or four sides (picture frame casing).

**Thick Replacement Extension Jambs**



To help preserve original alignment of trim and paint lines in replacement situations, special 1 1/8" (29) thick replacement extension jambs are available. Factory-applied and non-applied extension jambs are available in 1/16" (1.5) increments between 4 9/16" (116) and 7 1/8" (181). Non-applied extension jambs are available in 12" (3658) lineals. Detail on page 34.

For more information about **glass, patterned glass, art glass, grilles and TruScene insect screens**, see pages 12-14.

For more information about **product performance, installation instructions and accessories**, see pages 194-211 or visit [andersenwindows.com](http://andersenwindows.com).

**Drywall Return Bead**



A drywall return bead is available in a narrow or wide dimension with unfinished pine or prefinished white interiors. Can be ordered factory-applied or in non-applied lineals. Detail on page 34.

**Hardware**

**Corrosion-Resistant Components**



Corrosion-resistant hinge and operator arm hardware is designed for applications in harsh and corrosive environments such as heavy industrial or coastal areas.\*

**Window Opening Control Device Kit**



A Window Opening Control Device Kit is available, which limits sash travel to less than 4" (102) when the window is first opened. Available factory applied or field applied in stone, white and black.

**Special Use Operator Handles**

Available in Classic Series™ design only.

**Compact Operator Handle**



Specialty designed for use in situations

where blinds or other window treatments interfere with standard operator handle. Available in white or stone finish.

**Easy-Grip Handle**

Larger knob makes it easier to grip and operate. Available in white or stone finish.



**Metal T-Handle**



Our smallest operator handle, the metal T-handle, may make it more difficult for young children (5 and under) to open the window. For more information on child safety, write:

Andersen Corporation  
**LookOut for Kids® Program**  
100 Fourth Avenue North  
Bayport, MN 55003  
Call 1-800-313-8889 or email us at [lofk@andersencorp.com](mailto:lofk@andersencorp.com).

**Operator Spline Cover**



An operator spline cover is an attractive cap that covers the roto operator stud when the handle has been removed to control access or operation of the window. The operator spline cover should not be used on any window designated or intended for emergency escape or rescue. Please consult your local building code official for local egress code requirements.

**Power Operator for Awning Windows**



Awning windows can be ordered with an operator enhanced by PowerAssist™ technology that opens and closes the window with the touch of a button. Easy to install, the 24-volt system features a concealed window power drive, battery backup in case of a power outage and a moisture sensor that automatically closes the window when it rains. A wireless remote control is available (sold separately).

The PowerAssist system is controlled by a wall-mounted console, which includes a power box, battery, touch pad and mounting bracket. Windows can be ordered factory-prepped to save time or they can be ordered as a field kit. Power driver requires field installation. PowerAssist technology eliminates need for sash locks. Available for windows up to five feet wide. Not available for units with Stormwatch® Protection or performance upgrades.

**Security Sensors**

**VeriLock® Sensors**

VeriLock sensors are available in five colors. See page 15 for details.

**Open/Closed Sensors**

Wireless open/closed sensors are available in four colors. See page 15 for details.

**Glass**

**Andersen® Art Glass**

Andersen art glass panels come in a variety of original patterns. See pages 173-174 for details on Andersen art glass. Visit [andersenwindows.com/artglass](http://andersenwindows.com/artglass) for details and pattern information.

**Insect Screens**

**TruScene® Insect Screen**



Exclusive Andersen TruScene insect screens provide over 50% more clarity than our conventional insect screens for a beautiful unobstructed view. They allow more fresh air and sunlight in while doing a better job of keeping out small insects. For casement and awning windows, frames are available in stone, white, dark bronze or black or with pine veneer interiors to blend with the wood interior of the window.

**Conventional Insect Screen**

Conventional insect screens have charcoal powder-coated aluminum screen mesh. Available with frames in stone, white, dark bronze and black.

**Grilles**

Grilles are available in a variety of configurations and widths. For casement and awning grille patterns, see page 34.

**CAUTION:**

- Painting and staining may cause damage to rigid vinyl.
- Do not paint 400 Series windows with white, canvas, Sandtone, forest green, dark bronze or black exterior colors.
- Andersen does not warrant the adhesion or performance of homeowner-applied paint over vinyl or other factory-coated surfaces.
- 400 Series windows in Terratone color may be painted any color lighter than Terratone color using quality oil-based or latex paint.
- For vinyl painting instructions and preparation, contact your Andersen supplier.
- Do not paint weatherstrip.
- Creosote-based stains should not come in contact with Andersen products.
- Abrasive cleaners or solutions containing corrosive solvents should not be used on Andersen products.

\* Visit [andersenwindows.com/warranty](http://andersenwindows.com/warranty) for details. Dimensions in parentheses are in millimeters.

# REPLACEMENT CASEMENT & AWNING WINDOWS

## Replacement Sizes and Specification Formulas

### Casement Windows (stationary & venting)

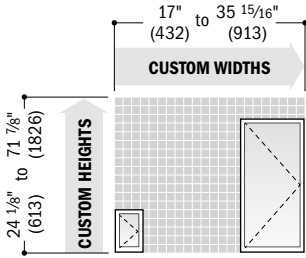

Available in 1/8" (3) increments between minimum and maximum widths and heights. Windows can also be custom sized to match standard sizes ending in a sixteenth of an inch. Some restrictions apply, contact your Andersen supplier. Custom sizing is available for single windows only. To achieve custom-size 2- or 3-wide combinations, join custom-size single windows. For minimum rough opening dimensions for joined windows, see specific joining instruction guides. Measurement guide for custom-size windows can be found at [andersenwindows.com/measure](http://andersenwindows.com/measure). Thick replacement extension jambs are available to preserve original alignment of trim and paint lines. Shown on page 39, see page 34 for detail.

	<b>Clear Opg.</b> Width = window width - 5.81" (148) = (window width - 9.66" (245)) X 1.07 = window width - 9.70" (246) Height = window height - 4.43" (113) = window height - 4.85" (123)	Width ≥ 24 1/8" (613) (hinge for widest clear opening) Width ≥ 28 3/8" (721) (hinge with wash mode & control bracket) Width ≥ 17" (432) (hinge with wash mode) Height ≥ 40 13/16" (1037) and < 48" (1219); Width ≥ 28 3/8" (721) and < 31 1/2" (800) All other window heights	<b>Min.R.O.</b> 	Width = window width + 1/2" (13) Height = window height + 1/2" (13)
	<b>Vent Opg.</b> Width = window width - 5.81" (148) = window width - 6.10" (155) Height = window height - 4.43" (113) = window height - 4.85" (123)	Width ≥ 24 1/8" (613) (hinge for widest clear opening) Width ≥ 17" (432) (hinge with wash mode) Height ≥ 40 13/16" (1037) and < 48" (1219); Width ≥ 28 3/8" (721) and < 31 1/2" (800) All other window heights	<b>Unobst. Gls.</b> 	Width = window width - 4.40" (112) Height = window height - 4.95" (126)

### Awning Windows (stationary & venting)

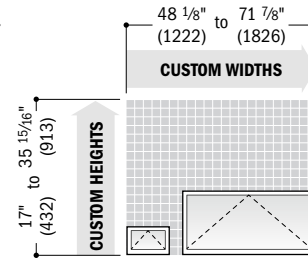
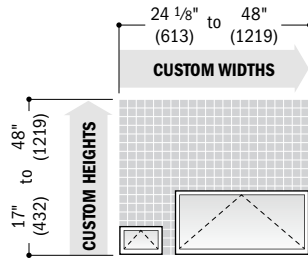
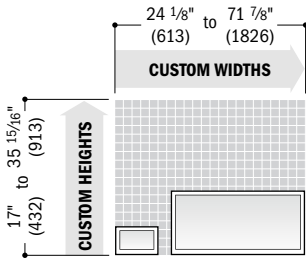

	<b>Clear Opg.</b> Width = window width - 4.53" (115) Depth = 6.38" (162) = 6.44" (164) = 6.50" (165)	Height ≥ 17" (432) and < 20 1/2" (521) Height ≥ 20 1/2" (521) and < 24 1/8" (613) All other window heights	<b>Min.R.O.</b> 	Width = window width + 1/2" (13) Height = window height + 1/2" (13)
	<b>Vent Opg.</b> Width = window width - 4.53" (115) Depth = 6.38" (162) = 6.44" (164) = 6.50" (165)	Height ≥ 17" (432) and < 20 1/2" (521) Height ≥ 20 1/2" (521) and < 24 1/8" (613) All other window heights	<b>Unobst. Gls.</b> 	Width = window width - 4.81" (122) Height = window height - 4.51" (115)

### Casement/Awning Picture and Transom Windows

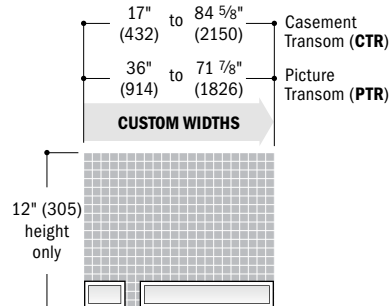
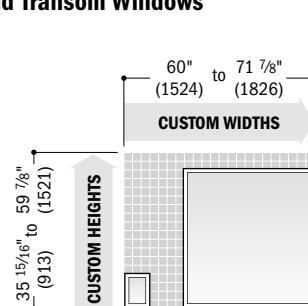
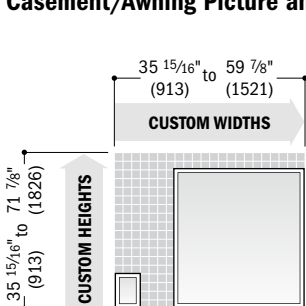

	<b>Min.R.O.</b> Width = window width - 1/2" (13) Height = window height - 1/2" (13)
	<b>Unobst. Gls.</b> Width = window width - 4.80" (122) Height = window height - 4.80" (122)

\* Dimensions in parentheses are in millimeters.  
 \* **Clear Opg.** (clear opening) formulas provide dimensions for determining area available for egress. **Vent Opg.** (vent opening) formulas provide dimensions for determining area available for passage of air. **Min. R.O.** (minimum rough opening) formulas provide minimum rough opening width and height dimensions. **Unobstr. Gls.** (unobstructed glass) formulas provide dimensions for determining area available for passage of light.  
 \* Refer to [andersenwindows.com/measure](http://andersenwindows.com/measure) for detailed instructions on how to properly measure for custom-size windows.

# COMPLEMENTARY CASEMENT WINDOWS

400 Series  
Complementary  
Casement Windows

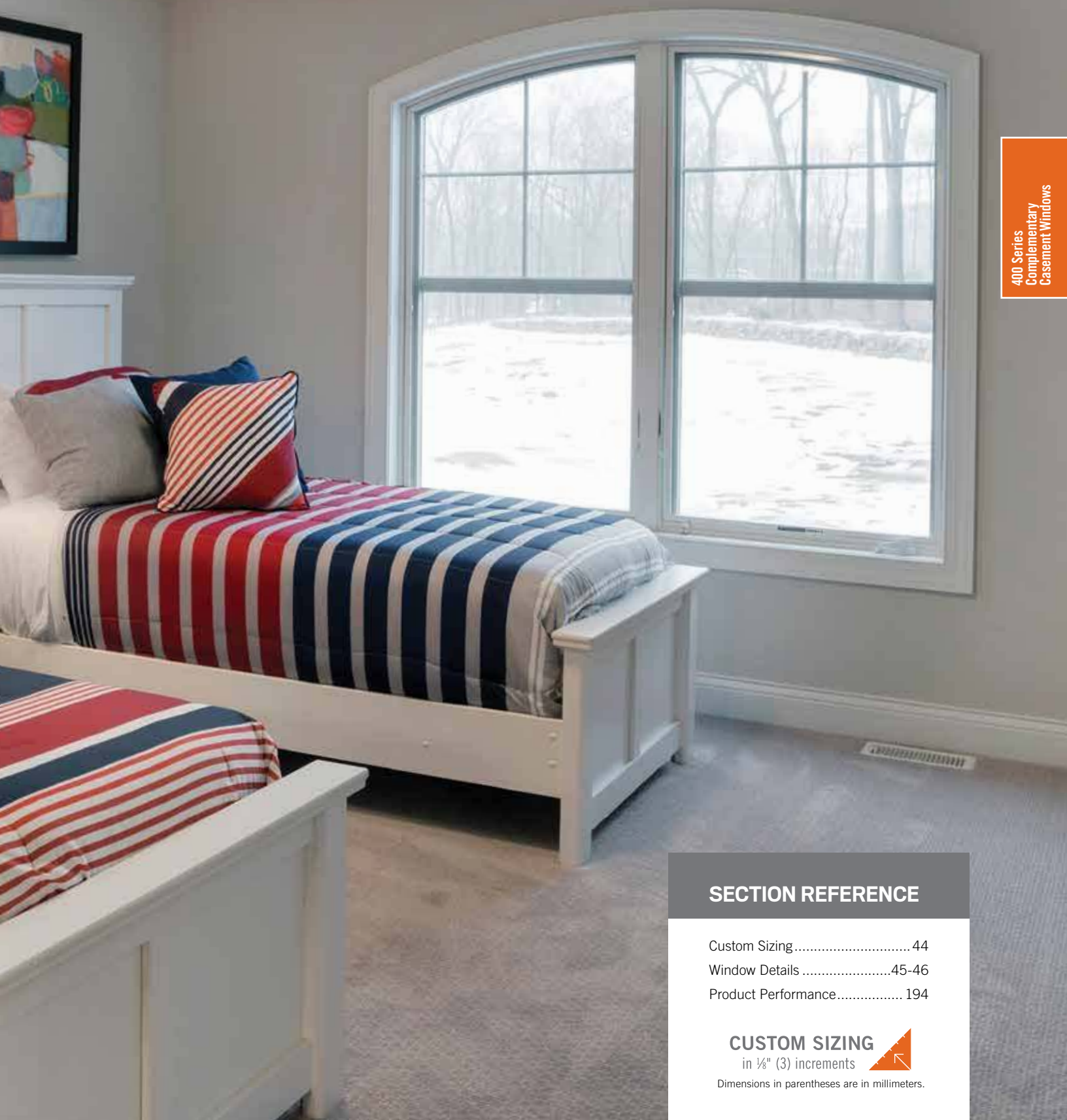

## SECTION REFERENCE

Custom Sizing .....	44
Window Details .....	45-46
Product Performance.....	194

**CUSTOM SIZING**  
in 1/8" (3) increments



Dimensions in parentheses are in millimeters.

# COMPLEMENTARY CASEMENT WINDOWS

## FEATURES

### Frame

**A** Heavy-duty extruded aluminum cladding protects the frame exterior, providing low-maintenance durability. Standard cladding finish meets AAMA 2604. An optional finish that meets the AAMA 2605 standard is also available.

**B** Wood frame members are treated with a water-repellent wood preservative for long-lasting\* protection and performance.

**C** Interior stops are unfinished. Low-maintenance prefinished white, dark bronze and black interiors are also available.

Installation flange extends 1 1/2" (38) around the perimeter of the unit for positioning and locating. Installation clips are standard for increased structural anchoring to building members. Mounted around the frame perimeter, the clips rotate into position and can be bent into place against the framing members to suit all jamb conditions.



### Hardware

#### Smooth Control Hardware System



The smooth control hardware system employs a worm gear drive for easy operation. Units have a wash mode with hinges that move the sash away from the frame to provide for easier glass cleaning on rectangular units. Arch and Springline™ casement units use the same smooth control hardware system with stainless steel butt hinges for smooth operation. Hardware option and finish must be specified. Operator handle and cover sold separately.

#### Single-Actuation Casement Lock



A single-actuation lock easily releases all locking points on casement sash while the reach-out action eliminates binding when closing. The lock handle is offered in finishes that coordinate with your specified hardware option.

### Sash

**D** Wood core members provide excellent structural stability and energy efficiency.

**E** Heavy-duty extruded aluminum cladding protects the sash exterior, providing low-maintenance durability.

**F** Weatherstrip throughout the unit provides a long-lasting, energy-efficient seal. Rain skirt is factory installed on the perimeter of the sash.

### Glass

**G** Silicone glazing bead combined with two-sided silicone tape provides superior weathertightness.

**H** High-Performance glass options include:

- Low-E4® glass
- Low-E4 HeatLock® glass
- Low-E4 Sun glass
- Low-E4 SmartSun™ glass
- Low-E4 SmartSun HeatLock glass

Tempered glass and other glass options are available. Contact your Andersen supplier.

A removable translucent film helps shield the glass from damage during delivery and construction and simplifies finishing at the jobsite.

### Patterned Glass

Patterned glass options are available. See page 12 for more details.

## EXTERIOR



## INTERIOR

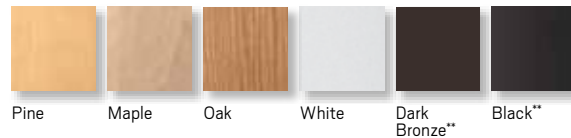

Naturally occurring variations in grain, color and texture of wood make each window one of a kind. All wood interiors are unfinished unless a prefinished option is specified.

## HARDWARE FINISHES

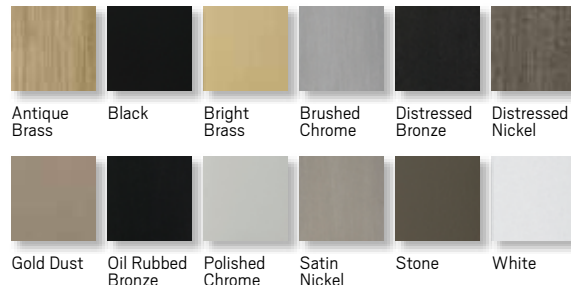

Distressed bronze and oil rubbed bronze are "living" finishes that will change with time and use.

## CASEMENT HARDWARE OPTIONS†

### CLASSIC SERIES™



Stone | White

### ESTATE™



**Antique Brass** | Bright Brass  
Brushed Chrome | Distressed Bronze  
Distressed Nickel | Oil Rubbed Bronze  
Polished Chrome | Satin Nickel

### TRADITIONAL FOLDING



Antique Brass | Black | Bright Brass  
**Distressed Bronze** | Distressed Nickel  
Gold Dust | Oil Rubbed Bronze | Satin Nickel  
Stone | White

### CONTEMPORARY FOLDING



Black | Bright Brass  
Gold Dust | Oil Rubbed Bronze  
**Satin Nickel** | Stone | White

Folding handle avoids interference with window decorating treatments.  
Bold name denotes finish shown.

\* Visit andersenwindows.com/warranty for details.

\*\* Dark bronze and black interiors are only available with dark bronze and black exteriors respectively.

† Hardware sold separately.

Dimensions in parentheses are in millimeters.

Printing limitations prevent exact replication of colors and finishes. See your Andersen supplier for actual color and finish samples.

## French Casement



Andersen® complementary French casements allow both sash to swing outward from the center, eliminating a center mullion post. They offer smooth operating multi-point locking mechanisms and hinges. The multi-point lock is activated with a single turn of a handle that simultaneously secures both sash. French casement windows have a unique locking handle that is available in antique brass, black, bright brass, brushed chrome, oil rubbed bronze, polished chrome, satin nickel, stone and white finishes.

## ACCESSORIES Sold Separately

### Frame

#### Extension Jamb



Complementary casement jamb depth is 3 3/8" (86). Extension base jambs are available in 1/8" (1.5) increments between 4 1/16" (116) and 7 1/8" (181). Additional dimensions are available. Contact your Andersen supplier for more information. Extension jambs are available in unfinished pine or prefinished white. Available for jobsite application or can be factory applied.

### Hardware

#### Corrosion-Resistant Components



Corrosion-resistant hinge and operator arm hardware is designed for applications in harsh and corrosive environments such as heavy industrial or coastal areas.\* Shown on a 400 Series casement window.

#### Window Opening Control Device Kit



A Window Opening Control Device Kit is available, which limits sash travel to less than 4" (102) when the window is first opened. Available factory applied or field applied in stone, white and black. Not available for French casement windows.

### Special Use Operator Handles

Available in Classic Series™ design only.

#### Compact Operator Handle



Specially designed for use in situations where blinds or other window treatments interfere with standard operator handle. Available in white or stone finish.

#### Easy-Grip Handle



Larger knob makes it easier to grip and operate. Available in white or stone finish.

#### Metal T-Handle



Our smallest operator handle, the metal T-handle, may make it more difficult for young children (5 and under) to open the window. For more information on child safety, write:

Andersen Corporation  
**LookOut for Kids® Program**  
100 Fourth Avenue North  
Bayport, MN 55003  
Call 1-800-313-8889 or email us at [lofk@andersencorp.com](mailto:lofk@andersencorp.com).

#### Operator Spline Cover



An operator spline cover is an attractive cap that covers the roto operator stud when the handle has been removed to control access or operation of the window. The operator spline cover should not be used on any window designated or intended for emergency escape or rescue. Please consult your local building code official for local egress code requirements.

### Security Sensors

#### VeriLock® Sensors

VeriLock sensors are available in five colors. See page 15 for details.

#### Open/Closed Sensors

Wireless open/closed sensors are available in four colors. See page 15 for details.

### Insect Screens

#### TruScene® Insect Screen



Exclusive Andersen TruScene insect screens provide over 50% more clarity than our conventional insect screens for a beautiful unobstructed view. They allow more fresh air and sunlight in while doing a better job of keeping out small insects. For casement and awning windows, frames are available in stone, white, dark bronze or black or with pine veneer interiors to blend with the wood interior of the window.

#### Conventional Insect Screen

Conventional insect screens have black fiberglass screen mesh. Optional charcoal powder-coated aluminum screen mesh is available. Frames are available in white, stone, dark bronze and black.

#### CAUTION:

- Do not paint weatherstrip.
- Creosote-based stains should not come in contact with Andersen products.
- Abrasive cleaners or solutions containing corrosive solvents should not be used on Andersen products.

\* Visit [andersenwindows.com/warranty](http://andersenwindows.com/warranty) for details. Dimensions in parentheses are in millimeters.

# COMPLEMENTARY CASEMENT WINDOWS

## Styles and Sizes

Choose left, right or stationary as viewed from the exterior. Custom-size complementary casement windows are available in 1/8" (3) increments between minimum and maximum widths and heights. Standard sizes are available to complement Andersen® 400 Series products. Contact your Andersen supplier for details.



### Casement

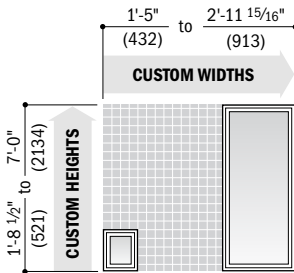

### Trapezoid Casement\*

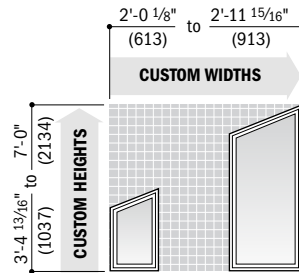

### Arch Casement\*

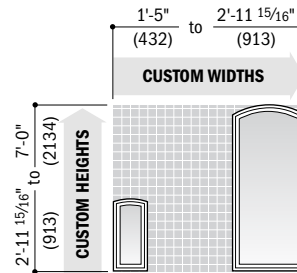

### Unequal Leg Arch Casement

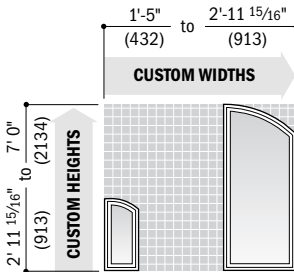

### Twin Arch Casement\*

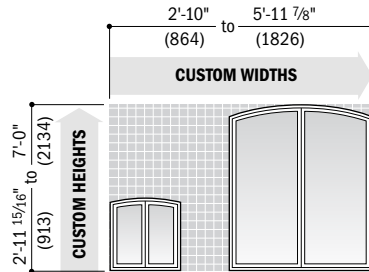

### Triple Arch Casement\*

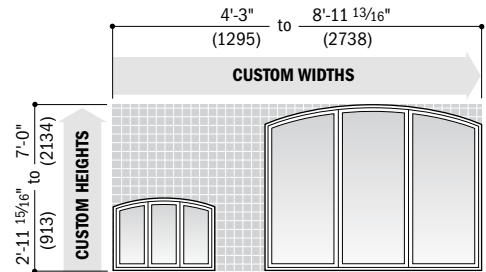

### Springline™ Casement\*

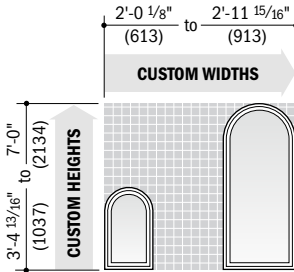

### Springline™ Flanker Casement\*

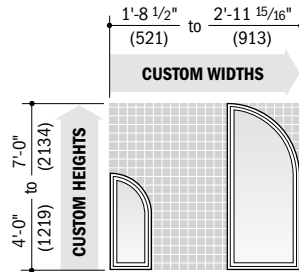

### Twin Springline™ Casement\*

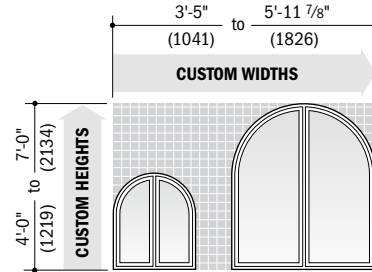

### French Casement

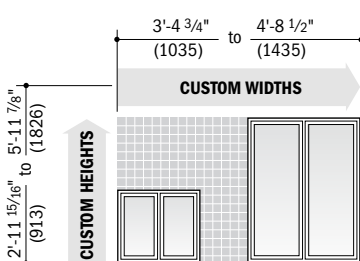

### Springline™ French Casement

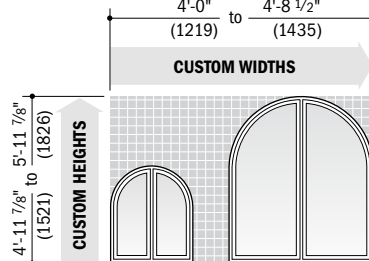

### Arch French Casement

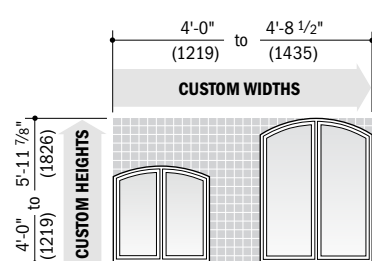

For casement picture and transom window sizes, contact your Andersen supplier.

\* Rough openings may need to be increased to allow for use of building wraps, flashing, sill panning, brackets, fasteners or other items. See pages 210-211 for more details.

• Dimensions in parentheses are in millimeters.

\*For exterior wall cladding that extends beyond the face of the window, there may be a reduction in the amount of opening "swing" when the top of the sash touches the wall cladding.

**Clad Complementary Venting Casement Window Details**

Scale 1 1/2" (38) = 1'-0" (305) – 1:8

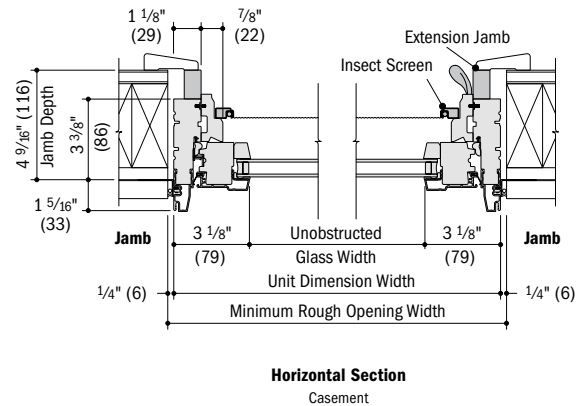
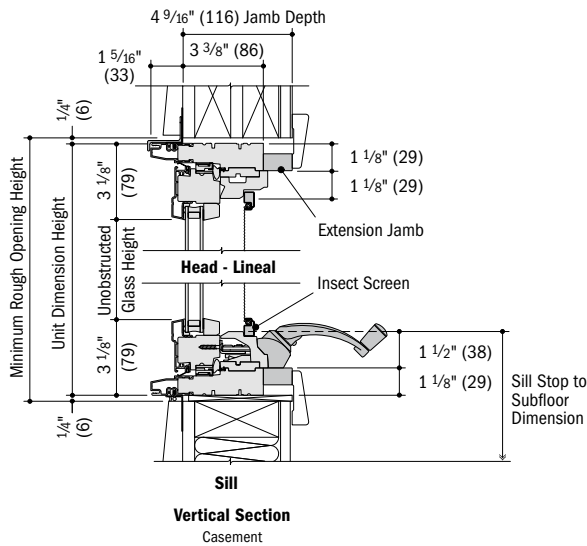
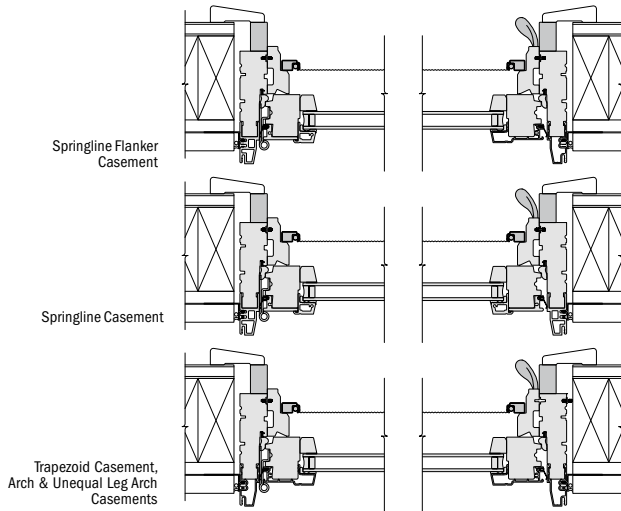
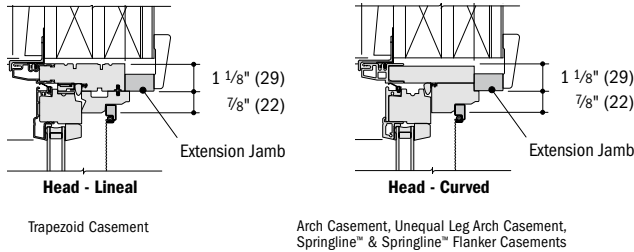

400 Series  
Complementary  
Casement Windows

**Clad Complementary Stationary Casement Window Details**

Scale 1 1/2" (38) = 1'-0" (305) – 1:8

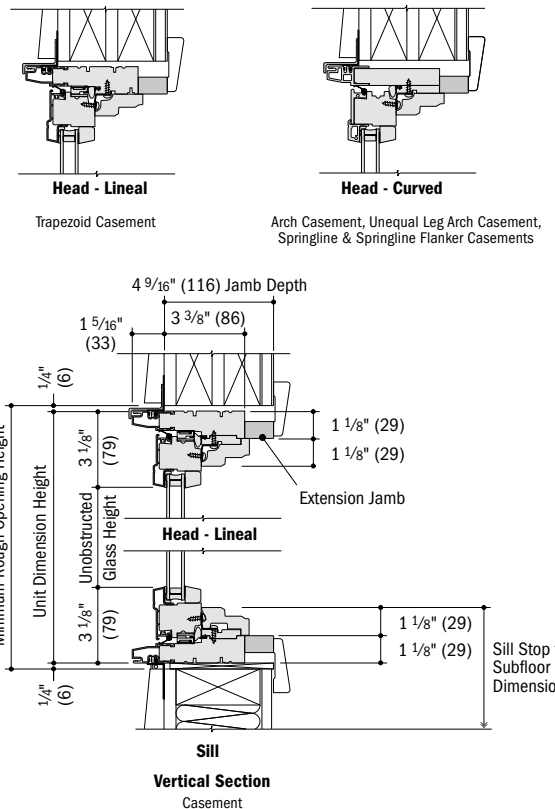
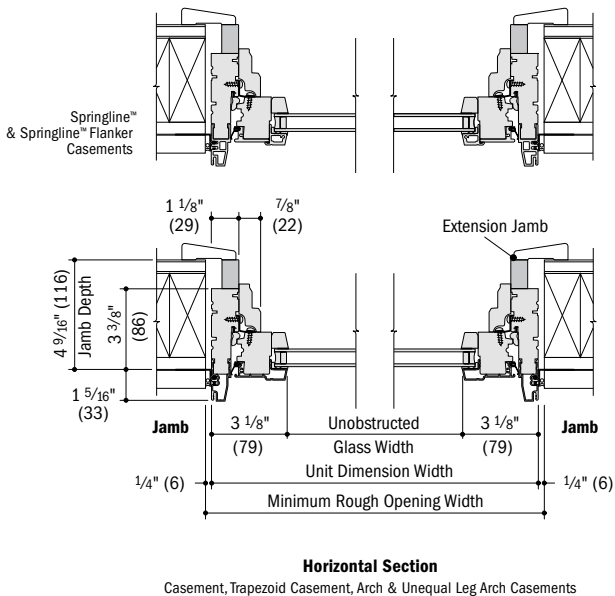

- 4 9/16" (116) jamb depth measurement is from back side of installation flange.
- Light-colored areas are parts included with window. Dark-colored areas are additional Andersen® parts required to complete window assembly as shown.
- **Rough openings may need to be increased to allow for use of building wraps, flashing, sill panning, brackets, fasteners or other items. See installation information on pages 210-211.**
- Details are for illustration only and are not intended to represent product installation methods or materials. Refer to unit installation guides at andersenwindows.com.
- Dimensions in parentheses are in millimeters.

# COMPLEMENTARY CASEMENT WINDOWS

## Clad Complementary Venting French Casement Window Details

Scale 1 1/2" (38) = 1'-0" (305) – 1:8

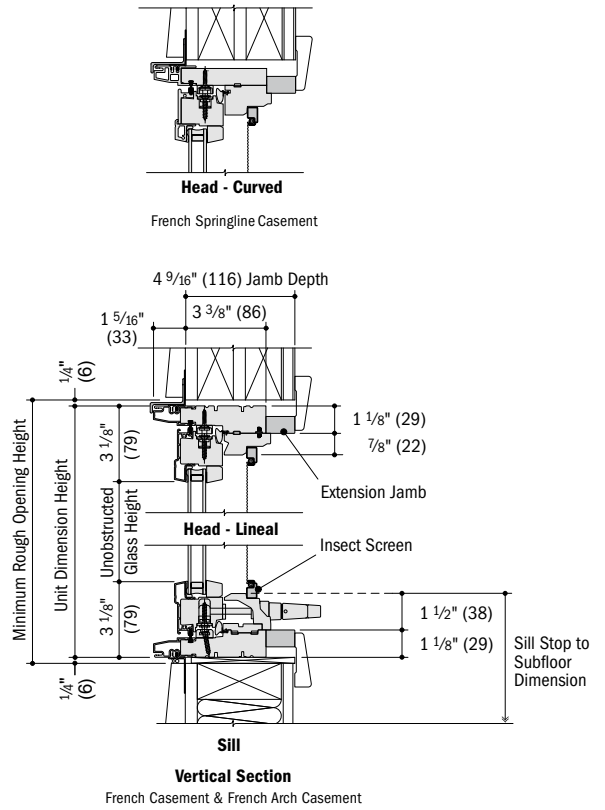
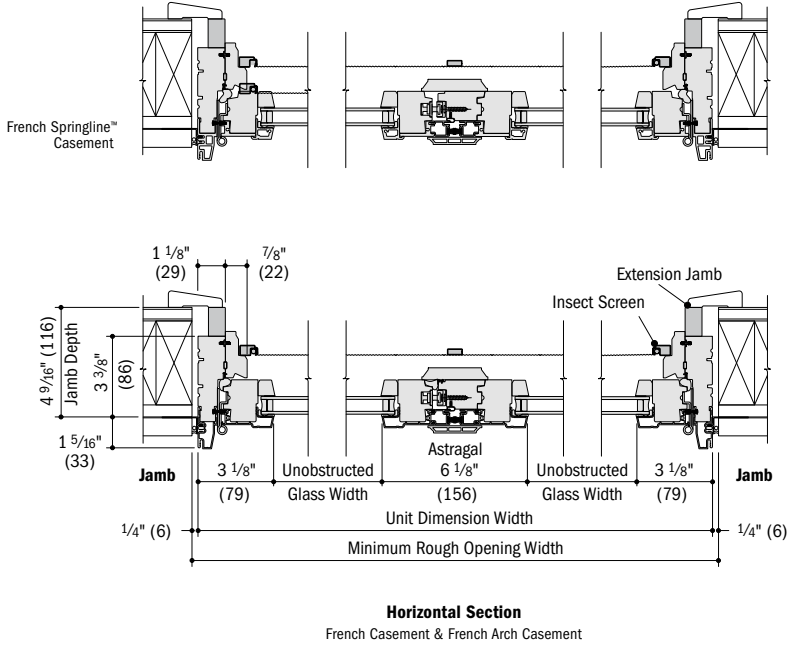

## Clad Complementary Stationary French Casement Window Details

Scale 1 1/2" (38) = 1'-0" (305) – 1:8

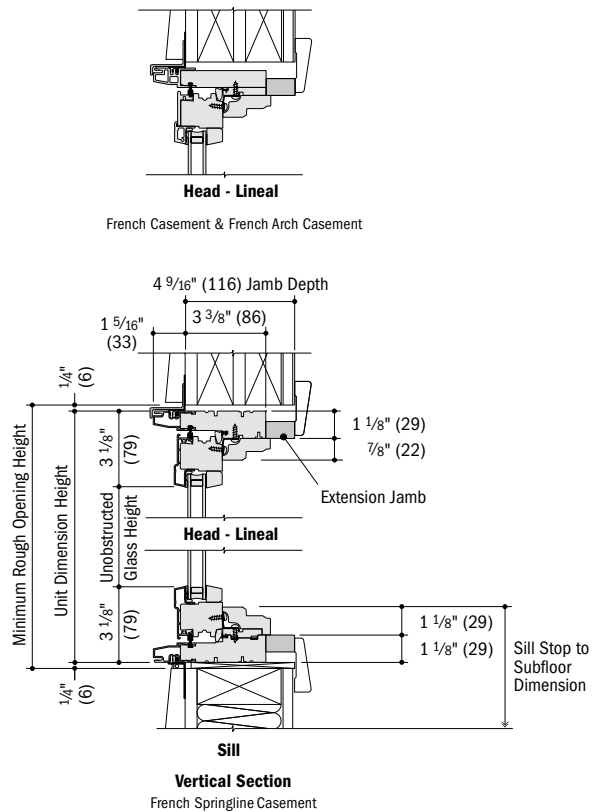
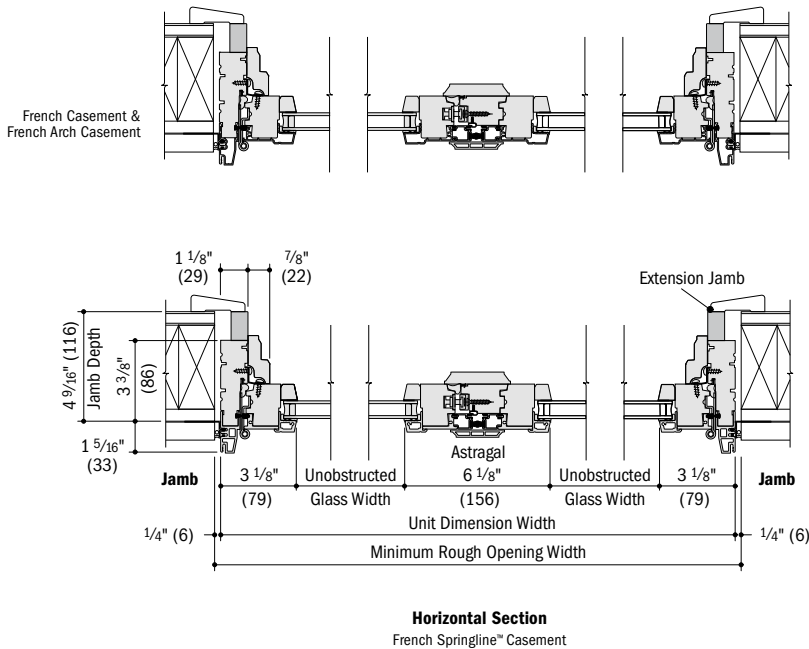

- 4 9/16" (116) jamb depth measurement is from back side of installation flange.
- Light-colored areas are parts included with window. Dark-colored areas are additional Andersen® parts required to complete window assembly as shown.
- Rough openings may need to be increased to allow for use of building wraps, flashing, sill panning, brackets, fasteners or other items. See installation information on pages 210-211.
- Details are for illustration only and are not intended to represent product installation methods or materials. Refer to unit installation guides at andersenwindows.com.
- Dimensions in parentheses are in millimeters.

# WOODWRIGHT® DOUBLE-HUNG FULL-FRAME WINDOWS

400 Series  
Woodwright® Double-Hung  
Full-Frame Windows

## SECTION REFERENCE

Tables of Sizes .....	50-56
Specifications .....	54-61
Custom Sizing .....	62
Grille Patterns .....	63
Window Details .....	63-64
Joining Details.....	65
Combination Designs .....	181
Product Performance.....	194

**CUSTOM SIZING**  
in 1/8" (3) increments



Dimensions in parentheses are in millimeters.

# WOODWRIGHT® DOUBLE-HUNG FULL-FRAME WINDOWS

## FEATURES

### Frame

**A** Perma-Shield® exterior cladding protects the frame – beautifully. Best of all, it's low maintenance and never needs painting.\*

**B** For exceptional long-lasting\* performance, sill members are constructed with a wood core and a Fibrex® material exterior.

**C** Natural wood stops are available in pine, oak, maple and prefinished white. Wood jamb liners add beauty and authenticity to the window interior.

**D** A factory-applied rigid vinyl flange on the head, sill and sides of the outer frame helps secure the unit to the structure.

**E** Multiple weatherstrip systems help provide a barrier against wind, rain and dust. The combination of spring tension vinyl, rigid vinyl and flexible bulb weatherstrip is efficient and effective.

**F** For units with white exterior color, exterior jamb liner is white. For all other units, the exterior jamb liner is gray.

### Sash

**G** Balancers in the sash enable contractors to screw through the jamb during installation without interfering with the window's operation.

### Wood Jamb Liner



**H** Natural wood sash interior with classic chamfer detailing. Available in pine, oak, maple or prefinished white.

**I** Low-maintenance sash exterior provides long-lasting\* protection and performance. Sash exteriors on most units include Fibrex material.

**J** Sash joints simulate the look of traditional mortise-and-tenon construction inside and out.

### Glass

**K** Silicone bed glazing provides superior weathertightness and durability.

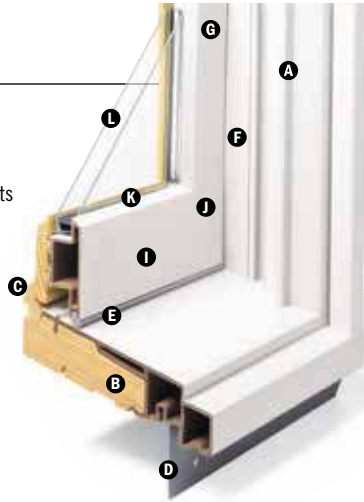

**L** High-Performance glass options include:

- Low-E4® glass
- Low-E4 HeatLock® glass
- Low-E4 Sun glass
- Low-E4 SmartSun™ glass
- Low-E4 SmartSun HeatLock glass

Tempered glass and other glass options are available. Contact your Andersen supplier.

A removable translucent film helps shield the glass from damage during delivery and construction and simplifies finishing at the jobsite.

### Patterned Glass

Patterned glass options are available. See page 12 for more details.

### Hardware



Standard lock and keeper design provides an easy tilt-to-clean feature integrated into the lock.

## StormWATCH PROTECTION

### Performance Grade (PG) Upgrade

Performance upgrades are available for select sizes allowing these units to achieve higher performance ratings. Performance Grade (PG) Ratings are more comprehensive than Design Pressure (DP) Ratings for measuring product performance. Use of this option will subtract 5/8" (16) from clear opening height. Contact your Andersen supplier for availability. For up-to-date performance information of individual products, visit [andersenwindows.com](http://andersenwindows.com).

Visit [andersenwindows.com/coastal](http://andersenwindows.com/coastal) for more information on Stormwatch Protection.

## EXTERIOR



## INTERIOR

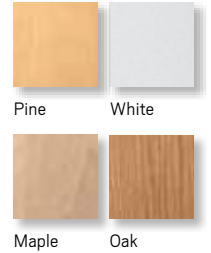

Naturally occurring variations in grain, color and texture of wood make each window one of a kind. All wood interiors are unfinished unless prefinished white is specified.

## HARDWARE FINISHES



Distressed bronze and oil rubbed bronze are "living" finishes that will change with time and use.

## DOUBLE-HUNG HARDWARE

### STANDARD Lock & Keeper



Antique Brass | **Black** | Bright Brass  
Brushed Chrome | Distressed Bronze  
Distressed Nickel | Gold Dust | Oil Rubbed Bronze  
Polished Chrome | Satin Nickel | White

## OPTIONAL DOUBLE-HUNG HARDWARE\*\*

### TRADITIONAL



Antique Brass | Black | Bright Brass | Brushed Chrome | Distressed Bronze | Distressed Nickel  
Gold Dust | **Oil Rubbed Bronze** | Polished Chrome | Satin Nickel | Stone | White

### CLASSIC SERIES™



Stone | **White**

### CONTEMPORARY



Antique Brass | Black | Bright Brass  
Brushed Chrome | Distressed Bronze  
**Distressed Nickel** | Gold Dust  
Oil Rubbed Bronze | Polished Chrome  
Satin Nickel | Stone | White

### ESTATE™



Antique Brass | Bright Brass  
Brushed Chrome | Distressed Bronze  
Distressed Nickel | Oil Rubbed Bronze  
Polished Chrome | **Satin Nickel**

Bold name denotes finish shown.

\* Visit [andersenwindows.com/warranty](http://andersenwindows.com/warranty) for details.

\*\* Hardware sold separately.

Dimensions in parentheses are in millimeters.

Printing limitations prevent exact replication of colors and finishes. See your Andersen supplier for actual color and finish samples.

## Shapes

Woodwright® windows are available in the following shapes.



Double-Hung



Arch Double-Hung



Unequal Leg Arch Double-Hung



Springline™ Single-Hung

## Sash Options\*



Cottage



Reverse Cottage

For more information about **glass, patterned glass, grilles and TruScene insect screens**, see pages 12-14.

For more information about **combination designs, product performance, installation instructions and accessories**, see pages 181-211 or visit [andersenwindows.com](http://andersenwindows.com).

## ACCESSORIES Sold Separately

### Frame

#### Extension Jamb



Standard jamb depth is 4 ½" (114). Extension jambs are available in unfinished pine or prefinished white. Some sizes may be veneered.

Factory-applied and non-applied interior extension jambs are available in ⅛" (1.5) increments between 5 ¼" (133) and 7 ⅛" (181). Extension jambs can be factory-applied to either three sides (stool and apron application) or four sides (picture frame casing).

#### Pine Stool



A clear pine stool is available and ready for finishing. The Woodwright stool is available in 4 ⅞" (116) for use in wall depths up to 5 ¼" (133), and 6 ⅞" (167) for use in wall depths up to 7 ⅞" (181). Works with 2 ¼" (57) and 2 ½" (64) wide casings. Shown on 400 Series tilt-wash double-hung window.

### Hardware

#### Window Opening Control Device Kit



A Window Opening Control Device Kit is available, which limits sash travel to less than 4" (102) when the window is first opened. Available factory applied or field applied in stone and white.

### Security Sensors

#### Open/Closed Sensors

Wireless open/closed sensors are available in four colors. See page 15 for details.

### Storm/Insect Screen Combination Unit\*\*



A self-storing storm window combined with an insect screen provides greater energy efficiency, while allowing ventilation when needed.

Constructed with an aluminum frame, single-pane upper and lower glass panels and charcoal powder-coated aluminum screen mesh. Available in white, Sandtone and Terratone to match product exteriors. Canvas, forest green, dark bronze and black available by special order.

Combination units can improve Sound Transmission Class (STC) and Outdoor Indoor Transmission Class (OITC) ratings. Ideal for projects near airports, busy roadways or other noisy environments. For example, adding a combination unit to a 400 Series tilt-wash double-hung (3862) unit with Low-E4® glass will improve its STC rating from 26 to 32. Contact your Andersen supplier for additional STC and OITC rating information.

### Insect Screens

#### Insect Screen Frames



Choose full insect screen or half insect screen. Half insect screen (shown above) allows ventilation without affecting the view through the upper sash. Frames are available in colors to match product exteriors.

#### TruScene® Insect Screen

Exclusive Andersen TruScene insect screens provide over 50% more clarity than our conventional insect screens for a beautiful unobstructed view. They allow more fresh air and sunlight in, while doing a better job of keeping out small insects.

#### Conventional Insect Screen

Conventional insect screens have charcoal powder-coated aluminum screen mesh.

### Grilles

Grilles are available in a variety of configurations and widths. For double-hung grille patterns, see page 62.

### Exterior Trim

This product is available with Andersen exterior trim. See pages 175-180 for details.

#### CAUTION:

- Painting and staining may cause damage to rigid vinyl.
- Do not paint 400 Series windows with white, canvas, Sandtone, forest green, dark bronze or black exterior colors.
- Andersen does not warrant the adhesion or performance of homeowner-applied paint over vinyl or other factory-coated surfaces.
- 400 Series windows in Terratone color may be painted any color lighter than Terratone color using quality oil-based or latex paint.
- For vinyl painting instructions and preparation, contact your Andersen supplier.
- Do not paint weatherstrip.
- Creosote-based stains should not come in contact with Andersen products.
- Abrasive cleaners or solutions containing corrosive solvents should not be used on Andersen products.

\* Shown on 400 Series tilt-wash double-hung windows.

\*\* Do not add combination units to windows with Low-E4 Sun glass, unless window glass is tempered. Combination units may also reduce the overall clear operable area of the window. See your local code official for egress requirements in your area. Dimensions in parentheses are in millimeters.

# WOODWRIGHT® DOUBLE-HUNG FULL-FRAME WINDOWS

## Table of Woodwright® Double-Hung Window Sizes

Scale 1/8" (3) = 1'-0" (305) – 1:96

Notes on the next page also apply to this page.

Window Dimension	1'-9 5/8" (549)	2'-1 5/8" (651)	2'-5 5/8" (752)	2'-7 5/8" (803)	2'-9 5/8" (854)	2'-11 5/8" (905)	3'-1 5/8" (956)	3'-5 5/8" (1057)	3'-9 5/8" (1159)
Minimum Rough Opening	1'-10 1/8" (562)	2'-2 1/8" (664)	2'-6 1/8" (765)	2'-8 1/8" (816)	2'-10 1/8" (867)	3'-0 1/8" (917)	3'-2 1/8" (968)	3'-6 1/8" (1070)	3'-10 1/8" (1172)
Unobstructed Glass (lower sash only)	15 5/8" (397)	19 5/8" (498)	23 5/8" (600)	25 5/8" (651)	27 5/8" (702)	29 5/8" (752)	31 5/8" (803)	35 5/8" (905)	39 5/8" (1006)

### CUSTOM WIDTHS – 16 1/2" to 45 5/8"

Window Dimension	16 1/2" (417)	20 1/2" (518)	24 1/2" (619)	28 1/2" (720)	32 1/2" (821)	36 1/2" (922)	40 1/2" (1023)	44 1/2" (1124)	45 5/8" (1166)
3'-0 7/8" (937)	WDH18210	WDH20210	WDH24210	WDH26210	WDH28210	WDH210210	WDH30210	WDH34210	WDH38210
3'-4 7/8" (1038)	WDH1832	WDH2032	WDH2432	WDH2632	WDH2832	WDH21032	WDH3032	WDH3432	WDH3832
3'-8 7/8" (1140)	WDH1836	WDH2036	WDH2436	WDH2636	WDH2836	WDH21036	WDH3036	WDH3436	WDH3836
4'-0 7/8" (1241)	WDH18310	WDH20310	WDH24310	WDH26310	WDH28310	WDH210310	WDH30310	WDH34310	WDH38310
4'-4 7/8" (1343)	WDH1842	WDH2042	WDH2442	WDH2642	WDH2842	WDH21042	WDH3042	WDH3442	WDH3842
4'-8 7/8" (1445)	WDH1846	WDH2046	WDH2446	WDH2646	WDH2846	WDH21046	WDH3046°	WDH3446°	WDH3846°
5'-0 7/8" (1546)	WDH18410	WDH20410	WDH24410	WDH26410	WDH28410	WDH210410°	WDH30410°	WDH34410°	WDH38410°
5'-4 7/8" (1648)	WDH1852	WDH2052	WDH2452	WDH2652	WDH2852°	WDH21052°	WDH3052°	WDH3452°	WDH3852°
5'-8 7/8" (1749)	WDH1856	WDH2056	WDH2456	WDH2656°	WDH2856°	WDH21056°	WDH3056°	WDH3456°	WDH3856°
6'-0 7/8" (1851)	WDH18510	WDH20510	WDH24510°	WDH26510°	WDH28510°	WDH210510°	WDH30510°	WDH34510°	WDH38510°
6'-4 7/8" (1953)	WDH1862	WDH2062	WDH2462°	WDH2662°	WDH2862°	WDH21062°	WDH3062°	WDH3462°	WDH3862°

2:3 cottage or 3:2 reverse cottage sash ratio available for all widths and heights. Size tables for windows with cottage or reverse cottage sash are available at [andersenwindow.com/sizing](http://andersenwindow.com/sizing).

**CUSTOM WIDTHS –**  
1'-4 1/2" (419) to 3'-9 5/8" (1159)

**CUSTOM HEIGHTS –**  
3'-0 7/8" (937) to 6'-4 7/8" (1953)

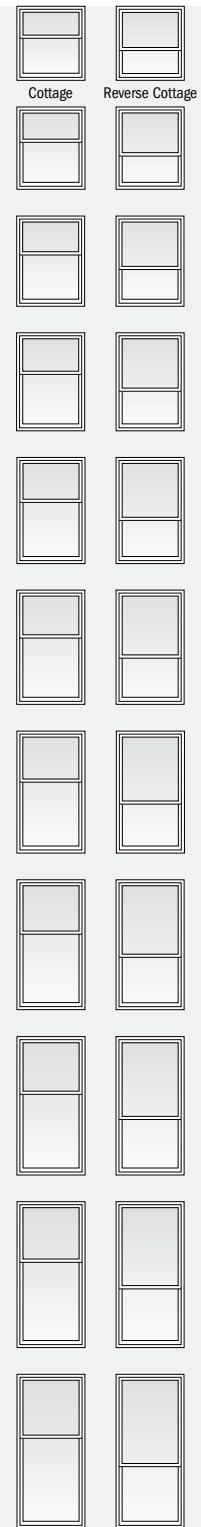

**Table of Woodwright® Springline™ Single-Hung Window Sizes**

Scale 1/8" (3) = 1'-0" (305) – 1:96

Window Dimension	2'-1 5/8" (651)	2'-5 5/8" (752)	2'-7 5/8" (803)	2'-9 5/8" (854)	2'-11 5/8" (905)	3'-1 5/8" (956)	3'-5 5/8" (1057)	3'-9 5/8" (1159)
<b>Minimum Rough Opening</b>	2'-2 1/8" (664)	2'-6 1/8" (765)	2'-8 1/8" (816)	2'-10 1/8" (867)	3'-0 1/8" (917)	3'-2 1/8" (968)	3'-6 1/8" (1070)	3'-10 1/8" (1172)
Unobstructed Glass (lower sash only)	19 5/8" (498)	23 5/8" (600)	25 5/8" (651)	27 5/8" (702)	29 5/8" (752)	31 5/8" (803)	35 5/8" (905)	39 5/8" (1006)

**CUSTOM WIDTHS – 25 5/8" to 45 5/8"**

	12 13/16" (325)	14 13/16" (376)	15 13/16" (402)	16 13/16" (427)	17 13/16" (452)	18 13/16" (478)	20 13/16" (529)	22 13/16" (579)
Unobstructed Glass (lower sash only)	12 13/16" (325)	14 13/16" (376)	15 13/16" (402)	16 13/16" (427)	17 13/16" (452)	18 13/16" (478)	20 13/16" (529)	22 13/16" (579)
Side Height	4'-4 13/16" (1341)	4'-6 13/16" (1392)	4'-7 13/16" (1418)	4'-8 13/16" (1443)	4'-9 13/16" (1468)	4'-10 13/16" (1494)	5'-0 13/16" (1545)	5'-2 13/16" (1595)
Radius and Chord Height	4'-4 13/16" (1341)	4'-6 13/16" (1392)	4'-7 13/16" (1418)	4'-8 13/16" (1443)	4'-9 13/16" (1468)	4'-10 13/16" (1494)	5'-0 13/16" (1545)	5'-2 13/16" (1595)
21 3/8" (543)	WS2042	WS2442	WS2642	WS2842	WS21042	WS3042	WS3442	WS3842
23 3/8" (594)	WS2046	WS2446	WS2646	WS2846	WS21046	WS3046	WS3446	WS3846
25 3/8" (645)	WS20410	WS24410	WS26410	WS28410	WS210410	WS30410	WS34410	WS38410
27 3/8" (695)	WS2052	WS2452	WS2652	WS2852	WS21052	WS3052	WS3452	WS3852
29 3/8" (746)	WS2056	WS2456	WS2656	WS2856	WS21056	WS3056	WS3456	WS3856
31 3/8" (797)	WS20510	WS24510	WS26510	WS28510	WS210510	WS30510	WS34510	WS38510
33 3/8" (848)	WS2062	WS2462	WS2662	WS2862	WS21062	WS3062	WS3462	WS3862

Custom-size windows are available in 1/8" (3) increments. See page 62 for custom sizing.

Grille patterns shown on page 63.

**Woodwright Springline Single-Hung only:** Minimum rough opening height is the same as the window dimension height. Upper sash does not operate and lower sash travel is limited by the radius of the upper sash. Contact your Andersen supplier for cottage and reverse cottage sash availability. **Side-by-side joining is not recommended.**

400 Series  
Woodwright® Double-Hung  
Full-Frame Windows

\*Window Dimension" always refers to outside frame to frame dimension.  
 • "Minimum Rough Opening" dimensions may need to be increased to allow for use of building wraps, flashing, sill panning, brackets, fasteners or other items. See pages 210-211 for more details.  
 • Dimensions in parentheses are in millimeters.  
 ◊ Meet or exceed clear opening area of 5.7 sq. ft. or 0.53 m<sup>2</sup>, clear opening width of 20" (508) and clear opening height of 24" (210). See tables on pages 57-58.



**Table of Woodwright® Unequal Leg Arch Double-Hung Window Sizes**

Scale 1/8" (3) = 1'-0" (305) – 1:96

Window Dimension	1'-9 5/8" (549)	2'-1 5/8" (651)	2'-5 5/8" (752)	2'-7 5/8" (803)	2'-9 5/8" (854)	2'-11 5/8" (905)	3'-1 5/8" (956)	3'-5 5/8" (1057)	3'-9 5/8" (1159)
<b>Minimum Rough Opening</b>	1'-10 1/8" (562)	2'-2 1/8" (664)	2'-6 1/8" (765)	2'-8 1/8" (816)	2'-10 1/8" (867)	3'-0 1/8" (917)	3'-2 1/8" (968)	3'-6 1/8" (1070)	3'-10 1/8" (1172)
Unobstructed Glass (lower sash only)	15 5/8" (397)	19 5/8" (498)	23 5/8" (600)	25 5/8" (651)	27 5/8" (702)	29 5/8" (752)	31 5/8" (803)	35 5/8" (905)	39 5/8" (1006)

**CUSTOM WIDTHS – 21 5/8" to 45 5/8"**

Radius	45 5/8" (1159)	45 5/8" (1159)	45 5/8" (1159)	45 5/8" (1159)	45 5/8" (1159)	96" (2438)	96" (2438)	96" (2438)	96" (2438)
Chord Height	5 7/16" (138)	7 7/8" (200)	10 15/16" (279)	12 3/4" (324)	14 13/16" (376)	6 13/16" (173)	7 1/16" (195)	9 1/2" (241)	11 9/16" (294)

3'-8 7/8" (1140)	3'-8 7/8" (1140)	17 3/8" (441)
4'-0 7/8" (1241)	4'-0 7/8" (1241)	19 3/8" (492)
4'-4 7/8" (1343)	4'-4 7/8" (1343)	21 3/8" (543)
4'-8 7/8" (1445)	4'-8 7/8" (1445)	23 3/8" (594)
5'-0 7/8" (1546)	5'-0 7/8" (1546)	25 3/8" (645)
5'-4 7/8" (1648)	5'-4 7/8" (1648)	27 3/8" (695)
5'-8 7/8" (1749)	5'-8 7/8" (1749)	29 3/8" (746)
6'-0 7/8" (1851)	6'-0 7/8" (1851)	31 3/8" (797)
6'-4 7/8" (1953)	6'-4 7/8" (1953)	33 3/8" (848)

**CUSTOM HEIGHTS – 44 7/8" to 76 7/8"**

Side Height

Custom-size windows are available in 1/8" (3) increments. See page 62 for custom sizing.

Lower sash travel is limited by the radius of the upper sash. Contact your Andersen supplier for cottage and reverse cottage sash availability.

Choose left facing or right facing as viewed from the exterior.

Arch double-hung with flanking unequal leg arch double-hungs.

Joining long sides creates a smooth arc. **Joining short sides is not recommended.**

WU1836, WU18310, WU20310, WU1842, WU2042, WU1846, WU2046, WU2446, WU18410, WU20410, WU24410, WU26410, WU1852, WU2052, WU2452, WU2652, WU2852, WU21052, WU3052, WU1856, WU2056, WU2456, WU2656, WU2856, WU21056, WU3056, WU18510, WU20510, WU24510, WU26510, WU28510, WU210510, WU30510, WU1862, WU2062, WU2462, WU2662, WU2862, WU21062, WU3062, WU3462, WU3862, WU34410, WU3452, WU3852, WU3456, WU3856, WU34510, WU38510, WU3462, WU3862

\*Window Dimension\* always refers to outside frame to frame dimension.  
 • \*Minimum Rough Opening\* dimensions may need to be increased to allow for use of building wraps, flashing, sill panning, brackets, fasteners or other items. See pages 210-211 for more details.  
 • Dimensions in parentheses are in millimeters.  
 ◊ Meet or exceed clear opening area of 5.7 sq. ft. or 0.53 m<sup>2</sup>; clear opening width of 20" (508) and clear opening height of 24" (210). See tables on pages 59-61.

400 Series  
Woodwright® Double-Hung  
Full-Frame Windows

# WOODWRIGHT® DOUBLE-HUNG FULL-FRAME WINDOWS

**Table of Woodwright® Transom Window Sizes**

Scale 1/8" (3) = 1'-0" (305) – 1:96

Window Dimension	1'-9 5/8" (549)	2'-1 5/8" (651)	2'-5 5/8" (752)	2'-7 5/8" (803)	2'-9 5/8" (854)	2'-11 5/8" (905)	3'-1 5/8" (956)	3'-5 5/8" (1057)	3'-9 5/8" (1159)	3'-11 5/16" (1202)
<b>Minimum Rough Opening</b>	1'-10 1/8" (562)	2'-2 1/8" (664)	2'-6 1/8" (765)	2'-8 1/8" (816)	2'-10 1/8" (867)	3'-0 1/8" (917)	3'-2 1/8" (968)	3'-6 1/8" (1070)	3'-10 1/8" (1172)	3'-11 7/8" (1215)
Unobstructed Glass	15 5/8" (397)	19 5/8" (498)	23 5/8" (600)	25 5/8" (651)	27 5/8" (702)	29 5/8" (752)	31 5/8" (803)	35 5/8" (905)	39 5/8" (1006)	41 1/4" (1048)

**CUSTOM WIDTHS – 12" to 75 5/16"**

CUSTOM HEIGHTS – 12" to 39 5/16"	1'-0" (305)	WTR1810	WTR2010	WTR2410	WTR2610	WTR2810	WTR21010	WTR3010	WTR3410	WTR3810	WTR31010
	1'-0 1/2" (318)	WTR1815	WTR2015	WTR2415	WTR2615	WTR2815	WTR21015	WTR3015	WTR3415	WTR3815	WTR31015
	1'-1 1/8" (331)	WTR1817	WTR2017	WTR2417	WTR2617	WTR2817	WTR21017	WTR3017	WTR3417	WTR3817	WTR31017
	1'-1 1/4" (344)	WTR18111	WTR20111	WTR24111	WTR26111	WTR28111	WTR210111	WTR30111	WTR34111	WTR38111	WTR310111
	1'-1 1/2" (357)	WTR1821	WTR2021	WTR2421	WTR2621	WTR2821	WTR21021	WTR3021	WTR3421	WTR3821	WTR31021
	1'-1 5/8" (370)	WTR1823	WTR2023	WTR2423	WTR2623	WTR2823	WTR21023	WTR3023	WTR3423	WTR3823	WTR31023
	1'-2" (383)	WTR1827	WTR2027	WTR2427	WTR2627	WTR2827	WTR21027	WTR3027	WTR3427	WTR3827	WTR31027
	1'-2 1/8" (396)	WTR1831	WTR2031	WTR2431	WTR2631	WTR2831	WTR21031	WTR3031	WTR3431	WTR3831	WTR31031
	1'-2 1/4" (409)										
	1'-2 1/2" (422)										

- "Window Dimension" always refers to outside frame to frame dimension.
- "Minimum Rough Opening" dimensions may need to be increased to allow for use of building wraps, flashing, sill panning, brackets, fasteners or other items. See pages 210-211 for more details.
- Dimensions in parentheses are in millimeters.

## Woodwright® Transom Window Area Specifications

Window Number	Glass Area Sq. Ft./ (m <sup>2</sup> )	Overall Window Area Sq. Ft./ (m <sup>2</sup> )
WTR1810	0.74 (0.07)	1.80 (0.17)
WTR1815	1.53 (0.14)	2.90 (0.27)
WTR1817	1.75 (0.16)	3.20 (0.30)
WTR18111	2.18 (0.20)	3.80 (0.35)
WTR1821	2.40 (0.22)	4.10 (0.38)
WTR1823	2.62 (0.24)	4.40 (0.41)
WTR1827	3.05 (0.28)	5.00 (0.46)
WTR1831	3.70 (0.34)	5.90 (0.55)
WTR2010	0.93 (0.09)	2.14 (0.20)
WTR2015	1.93 (0.18)	3.44 (0.32)
WTR2017	2.20 (0.20)	3.79 (0.35)
WTR20111	2.74 (0.25)	4.50 (0.42)
WTR2021	3.02 (0.28)	4.86 (0.45)
WTR2023	3.29 (0.31)	5.22 (0.48)
WTR2027	3.83 (0.36)	5.93 (0.55)
WTR2031	4.65 (0.43)	7.00 (0.65)
WTR2410	1.12 (0.10)	2.47 (0.23)
WTR2415	2.32 (0.22)	3.97 (0.37)
WTR2417	2.65 (0.25)	4.38 (0.41)
WTR24111	3.30 (0.31)	5.21 (0.48)

Window Number	Glass Area Sq. Ft./ (m <sup>2</sup> )	Overall Window Area Sq. Ft./ (m <sup>2</sup> )
WTR2421	3.63 (0.34)	5.62 (0.52)
WTR2423	3.96 (0.37)	6.03 (0.56)
WTR2427	4.61 (0.43)	6.85 (0.64)
WTR2431	5.60 (0.52)	8.09 (0.75)
WTR2610	1.21 (0.11)	2.64 (0.24)
WTR2615	2.51 (0.23)	4.24 (0.39)
WTR2617	2.87 (0.27)	4.68 (0.43)
WTR26111	3.58 (0.33)	5.56 (0.52)
WTR2621	3.94 (0.37)	6.00 (0.56)
WTR2623	4.29 (0.40)	6.44 (0.60)
WTR2627	5.00 (0.46)	7.32 (0.68)
WTR2631	6.07 (0.56)	8.63 (0.80)
WTR2810	1.31 (0.12)	2.80 (0.26)
WTR2815	2.71 (0.25)	4.51 (0.42)
WTR2817	3.09 (0.29)	4.98 (0.46)
WTR28111	3.86 (0.36)	5.91 (0.55)
WTR2821	4.24 (0.39)	6.38 (0.59)
WTR2823	4.63 (0.43)	6.84 (0.64)
WTR2827	5.40 (0.50)	7.78 (0.72)
WTR2831	6.55 (0.61)	9.18 (0.85)

Window Number	Glass Area Sq. Ft./ (m <sup>2</sup> )	Overall Window Area Sq. Ft./ (m <sup>2</sup> )
WTR21010	1.40 (0.13)	2.97 (0.28)
WTR21015	2.91 (0.27)	4.78 (0.44)
WTR21017	3.32 (0.31)	5.27 (0.49)
WTR210111	4.14 (0.38)	6.26 (0.58)
WTR21021	4.55 (0.42)	6.76 (0.63)
WTR21023	4.96 (0.46)	7.25 (0.67)
WTR21027	5.79 (0.54)	8.24 (0.77)
WTR21031	7.02 (0.65)	9.73 (0.90)
WTR3010	1.50 (0.14)	3.14 (0.29)
WTR3015	3.10 (0.29)	5.05 (0.47)
WTR3017	3.54 (0.33)	5.57 (0.52)
WTR30111	4.42 (0.41)	6.61 (0.61)
WTR3021	4.86 (0.45)	7.14 (0.66)
WTR3023	5.30 (0.49)	7.66 (0.71)
WTR3027	6.18 (0.57)	8.70 (0.81)
WTR3031	7.49 (0.70)	10.27 (0.95)
WTR3410	1.69 (0.16)	3.47 (0.32)
WTR3415	3.49 (0.32)	5.58 (0.52)

• Dimensions in parentheses are in square meters.

*continued on next page*

4'-3 5/16" (1303)	4'-11 5/16" (1506)	5'-7 5/16" (1710)	6'-3 5/16" (1913)
4'-3 7/8" (1317)	4'-11 7/8" (1520)	5'-7 7/8" (1724)	6'-3 7/8" (1927)
45 1/4" (1149)	53 1/4" (1353)	61 1/4" (1556)	69 1/4" (1745)



Custom-size windows are available in 1/8" (3) increments. See page 62 for custom sizing.

Grille patterns shown on page 63.



\*"Window Dimension" always refers to outside frame to frame dimension.  
 \*\*Minimum Rough Opening" dimensions may need to be increased to allow for use of building wraps, flashing, sill panning, brackets, fasteners or other items. See pages 210-211 for more details.  
 \*Dimensions in parentheses are in millimeters.

### Woodwright® Transom Window Area Specifications *(continued)*

Window Number	Glass Area Sq. Ft./ (m <sup>2</sup> )	Overall Window Area Sq. Ft./ (m <sup>2</sup> )
WTR3417	3.99 (0.37)	6.16 (0.57)
WTR34111	4.98 (0.46)	7.32 (0.68)
WTR3421	5.47 (0.51)	7.90 (0.73)
WTR3423	5.97 (0.55)	8.47 (0.79)
WTR3427	6.96 (0.65)	9.63 (0.89)
WTR3431	8.44 (0.78)	11.36 (1.06)
WTR3810	1.87 (0.17)	3.80 (0.35)
WTR3815	3.89 (0.36)	6.12 (0.57)
WTR3817	4.44 (0.41)	6.75 (0.63)
WTR38111	5.54 (0.51)	8.02 (0.75)
WTR3821	6.09 (0.57)	8.65 (0.80)
WTR3823	6.64 (0.62)	9.29 (0.86)
WTR3827	7.74 (0.72)	10.55 (0.98)
WTR3831	9.39 (0.87)	12.46 (1.16)
WTR31010	1.95 (0.18)	3.94 (0.37)
WTR31015	4.05 (0.38)	6.35 (0.59)
WTR31017	4.63 (0.43)	7.00 (0.65)
WTR310111	5.77 (0.54)	8.32 (0.77)
WTR31021	6.35 (0.59)	8.97 (0.83)
WTR31023	6.92 (0.64)	9.63 (0.89)

Window Number	Glass Area Sq. Ft./ (m <sup>2</sup> )	Overall Window Area Sq. Ft./ (m <sup>2</sup> )
WTR31027	8.07 (0.75)	10.95 (1.02)
WTR31031	9.79 (0.91)	12.92 (1.20)
WTR4210	2.14 (0.20)	4.28 (0.40)
WTR4215	4.44 (0.41)	6.88 (0.64)
WTR4217	5.07 (0.47)	7.59 (0.71)
WTR42111	6.33 (0.59)	9.02 (0.84)
WTR4221	6.96 (0.65)	9.73 (0.90)
WTR4223	7.59 (0.71)	10.45 (0.97)
WTR4227	8.85 (0.82)	11.87 (1.10)
WTR4231	10.74 (1.00)	14.01 (1.30)
WTR41010	2.52 (0.23)	4.94 (0.46)
WTR41015	5.23 (0.49)	7.95 (0.74)
WTR41017	5.97 (0.55)	8.78 (0.82)
WTR410111	7.45 (0.69)	10.43 (0.97)
WTR41021	8.19 (0.76)	11.25 (1.05)
WTR41023	8.93 (0.83)	12.07 (1.12)
WTR41027	10.41 (0.97)	13.72 (1.27)
WTR41031	12.63 (1.17)	16.19 (1.50)
WTR5610	2.90 (0.27)	5.61 (0.52)
WTR5615	6.01 (0.56)	9.03 (0.84)

Window Number	Glass Area Sq. Ft./ (m <sup>2</sup> )	Overall Window Area Sq. Ft./ (m <sup>2</sup> )
WTR5617	6.87 (0.64)	9.96 (0.93)
WTR56111	8.57 (0.80)	11.83 (1.10)
WTR5621	9.42 (0.88)	12.77 (1.19)
WTR5623	10.27 (0.95)	13.70 (1.27)
WTR5627	11.98 (1.11)	15.57 (1.45)
WTR5631	14.53 (1.35)	18.38 (1.71)
WTR6210	3.28 (0.30)	6.28 (0.58)
WTR6215	6.80 (0.63)	10.10 (0.94)
WTR6217	7.76 (0.72)	11.15 (1.04)
WTR62111	9.69 (0.90)	13.24 (1.23)
WTR6221	10.65 (0.99)	14.28 (1.33)
WTR6223	11.61 (1.08)	15.33 (1.42)
WTR6227	13.54 (1.26)	17.42 (1.62)
WTR6231	16.43 (1.53)	20.56 (1.91)

\* Dimensions in parentheses are in square meters.

# WOODWRIGHT® DOUBLE-HUNG FULL-FRAME WINDOWS

**Table of Woodwright® Picture Window Sizes**

Scale 1/8" (3) = 1'-0" (305) – 1:96

Window Dimension	1'-0"	3'-1 5/8"	3'-5 5/8"	3'-11 5/16"	4'-3 5/16"	4'-11 5/16"	5'-7 5/16"
	(305)	(956)	(1057)	(1202)	(1303)	(1507)	(1710)
<b>Minimum Rough Opening</b>	1'-0 1/2"	3'-2 1/8"	3'-6 1/8"	3'-11 7/8"	4'-3 7/8"	4'-11 7/8"	5'-7 7/8"
	(318)	(968)	(1070)	(1216)	(1318)	(1521)	(1724)
Unobstructed Glass	6"	31 5/8"	35 5/8"	41 1/4"	45 1/4"	53 1/4"	61 1/4"
	(152)	(803)	(905)	(1048)	(1149)	(1353)	(1556)

		CUSTOM WIDTHS – 12" to 67 5/16"						
CUSTOM HEIGHTS – 14 1/2" to 76 7/8"	4'-0 7/8" (1241)							
		WPW10310	WPW30310	WPW34310	WPW310310	WPW42310	WPW410310	WPW56310
	4'-4 7/8" (1343)							
		WPW1042	WPW3042	WPW3442	WPW31042	WPW4242	WPW41042	WPW5642
	4'-8 7/8" (1445)							
		WPW1046	WPW3046	WPW3446	WPW31046	WPW4246	WPW41046	WPW5646
	5'-0 7/8" (1547)							
		WPW10410	WPW30410	WPW34410	WPW310410	WPW42410	WPW410410	WPW56410
5'-4 7/8" (1648)								
	WPW1052	WPW3052	WPW3452	WPW31052	WPW4252	WPW41052	WPW5652	
5'-8 7/8" (1749)								
	WPW1056	WPW3056	WPW3456	WPW31056	WPW4256	WPW41056	WPW5656	
6'-0 7/8" (1851)								
	WPW10510	WPW30510	WPW34510	WPW310510	WPW42510	WPW410510	WPW56510	
6'-4 7/8" (1953)								
	WPW1062	WPW3062	WPW3462	WPW31062	WPW4262	WPW41062	WPW5662	



Custom-size windows are available in 1/8" (3) increments. See page 62 for custom sizing.

Grille patterns shown on page 63.

• "Window Dimension" always refers to outside frame to frame dimension.  
 • "Minimum Rough Opening" dimensions may need to be increased to allow for use of building wraps, flashing, sill panning, brackets, fasteners or other items. See pages 210-211 for more details.  
 • Dimensions in parentheses are in millimeters.

**Woodwright® Double-Hung Window Opening and Area Specifications**

Window Number	Clear Opening Area Sq. Ft./ (m <sup>2</sup> )	Clear Opening in Full Open Position		Glass Area Sq. Ft./ (m <sup>2</sup> )	Vent Area Sq. Ft./ (m <sup>2</sup> )	Top of Subfloor to Top of Inside Sill Stop Inches/(mm)	Overall Window Area Sq. Ft./ (m <sup>2</sup> )
		Width Inches/(mm)	Height Inches/(mm)				
WDH18210	1.73 (0.16)	17 1/8" (454)	14 1/4" (362)	2.90 (0.27)	1.78 (0.17)	48 1/2" (1231)	5.53 (0.51)
WDH1832	1.98 (0.18)	17 1/8" (454)	16 1/4" (412)	3.32 (0.31)	2.03 (0.19)	44 1/2" (1130)	6.14 (0.57)
WDH1836	2.23 (0.21)	17 1/8" (454)	18 1/4" (463)	3.74 (0.35)	2.28 (0.21)	40 1/2" (1028)	6.74 (0.63)
WDH18310	2.48 (0.23)	17 1/8" (454)	20 1/4" (514)	4.15 (0.39)	2.53 (0.24)	36 1/2" (926)	7.34 (0.68)
WDH1842	2.73 (0.25)	17 1/8" (454)	22 1/4" (565)	4.57 (0.43)	2.78 (0.26)	32 1/2" (825)	7.94 (0.74)
WDH1846	2.90 (0.27)	17 1/8" (454)	24 1/4" (616)	4.98 (0.46)	3.02 (0.28)	28 1/2" (723)	8.54 (0.79)
WDH18410	3.22 (0.30)	17 1/8" (454)	26 1/4" (666)	5.40 (0.50)	3.27 (0.30)	24 1/2" (622)	9.14 (0.85)
WDH1852	3.47 (0.32)	17 1/8" (454)	28 1/4" (717)	5.81 (0.54)	3.52 (0.33)	20 1/2" (520)	9.74 (0.91)
WDH1856	3.72 (0.35)	17 1/8" (454)	30 1/4" (768)	6.23 (0.58)	3.02 (0.28)	16 1/2" (418)	10.34 (0.96)
WDH18510	3.97 (0.37)	17 1/8" (454)	32 1/4" (819)	6.65 (0.62)	4.02 (0.37)	12 1/2" (317)	10.94 (1.02)
WDH1862	4.22 (0.39)	17 1/8" (454)	34 1/4" (870)	7.06 (0.66)	4.26 (0.40)	8 1/2" (215)	11.54 (1.07)
WDH20210	2.12 (0.20)	21 1/8" (556)	14 1/4" (362)	3.68 (0.34)	2.18 (0.20)	48 1/2" (1231)	6.56 (0.61)
WDH2032	2.42 (0.23)	21 1/8" (556)	16 1/4" (412)	4.21 (0.39)	2.48 (0.23)	44 1/2" (1130)	7.27 (0.68)
WDH2036	2.73 (0.25)	21 1/8" (556)	18 1/4" (463)	4.73 (0.44)	2.79 (0.26)	40 1/2" (1028)	7.98 (0.74)
WDH20310	3.03 (0.28)	21 1/8" (556)	20 1/4" (514)	5.26 (0.49)	3.09 (0.29)	36 1/2" (926)	8.69 (0.81)
WDH2042	3.34 (0.31)	21 1/8" (556)	22 1/4" (565)	5.79 (0.54)	3.40 (0.32)	32 1/2" (825)	9.41 (0.87)
WDH2046	3.55 (0.33)	21 1/8" (556)	24 1/4" (616)	6.31 (0.59)	3.70 (0.34)	28 1/2" (723)	10.12 (0.94)
WDH20410	3.94 (0.37)	21 1/8" (556)	26 1/4" (666)	6.84 (0.64)	4.00 (0.37)	24 1/2" (622)	10.83 (1.01)
WDH2052	4.25 (0.39)	21 1/8" (556)	28 1/4" (717)	7.37 (0.69)	4.31 (0.40)	20 1/2" (520)	11.54 (1.07)
WDH2056	4.55 (0.42)	21 1/8" (556)	30 1/4" (768)	7.89 (0.73)	3.70 (0.34)	16 1/2" (418)	12.25 (1.14)
WDH20510	4.86 (0.45)	21 1/8" (556)	32 1/4" (819)	8.42 (0.78)	4.92 (0.46)	12 1/2" (317)	12.96 (1.20)
WDH2062	5.16 (0.48)	21 1/8" (556)	34 1/4" (870)	8.95 (0.83)	5.22 (0.49)	8 1/2" (215)	13.68 (1.27)
WDH24210	2.51 (0.23)	25 1/8" (657)	14 1/4" (362)	4.46 (0.41)	2.58 (0.24)	48 1/2" (1231)	7.58 (0.70)
WDH2432	2.86 (0.27)	25 1/8" (657)	16 1/4" (412)	5.09 (0.47)	2.94 (0.27)	44 1/2" (1130)	8.40 (0.78)
WDH2436	3.22 (0.30)	25 1/8" (657)	18 1/4" (463)	5.73 (0.53)	3.30 (0.31)	40 1/2" (1028)	9.23 (0.86)
WDH24310	3.59 (0.33)	25 1/8" (657)	20 1/4" (514)	6.37 (0.59)	3.66 (0.34)	36 1/2" (926)	10.05 (0.93)
WDH2442	3.95 (0.37)	25 1/8" (657)	22 1/4" (565)	7.01 (0.65)	4.02 (0.37)	32 1/2" (825)	10.87 (1.01)
WDH2446	4.19 (0.39)	25 1/8" (657)	24 1/4" (616)	7.65 (0.71)	4.38 (0.41)	28 1/2" (724)	11.70 (1.09)
WDH24410	4.66 (0.43)	25 1/8" (657)	26 1/4" (666)	8.28 (0.77)	4.74 (0.44)	24 1/2" (622)	12.52 (1.16)
WDH2452	5.02 (0.47)	25 1/8" (657)	28 1/4" (717)	8.92 (0.83)	5.10 (0.47)	20 1/2" (520)	13.34 (1.24)
WDH2456	5.38 (0.50)	25 1/8" (657)	30 1/4" (768)	9.56 (0.89)	4.38 (0.41)	16 1/2" (418)	14.17 (1.32)
WDH24510	5.74 (0.53)	25 1/8" (657)	32 1/4" (819)	10.20 (0.95)	5.81 (0.54)	12 1/2" (317)	14.99 (1.39)
WDH2462	6.10 (0.57)	25 1/8" (657)	34 1/4" (870)	10.84 (1.01)	6.17 (0.57)	8 1/2" (215)	15.81 (1.47)
WDH26210	2.71 (0.25)	27 1/8" (708)	14 1/4" (362)	4.84 (0.45)	2.78 (0.26)	48 1/2" (1231)	8.09 (0.75)
WDH2632	3.09 (0.29)	27 1/8" (708)	16 1/4" (412)	5.54 (0.52)	3.17 (0.30)	44 1/2" (1130)	8.97 (0.83)
WDH2636	3.48 (0.32)	27 1/8" (708)	18 1/4" (463)	6.23 (0.58)	3.55 (0.33)	40 1/2" (1028)	9.85 (0.92)
WDH26310	3.86 (0.36)	27 1/8" (708)	20 1/4" (514)	6.92 (0.64)	3.94 (0.37)	36 1/2" (926)	10.73 (1.00)
WDH2642	4.25 (0.40)	27 1/8" (708)	22 1/4" (565)	7.62 (0.71)	4.33 (0.40)	32 1/2" (825)	11.61 (1.08)
WDH2646	4.52 (0.42)	27 1/8" (708)	24 1/4" (616)	8.31 (0.77)	4.71 (0.44)	28 1/2" (723)	12.49 (1.16)
WDH26410	5.02 (0.47)	27 1/8" (708)	26 1/4" (666)	9.01 (0.84)	5.10 (0.47)	24 1/2" (622)	13.36 (1.24)
WDH2652	5.41 (0.50)	27 1/8" (708)	28 1/4" (717)	9.70 (0.90)	5.49 (0.51)	20 1/2" (520)	14.24 (1.32)
WDH2656	5.80 (0.54)	27 1/8" (708)	30 1/4" (768)	10.39 (0.96)	4.71 (0.44)	16 1/2" (418)	15.12 (1.41)
WDH26510	6.19 (0.57)	27 1/8" (708)	32 1/4" (819)	11.09 (1.03)	6.26 (0.58)	12 1/2" (317)	16.00 (1.49)
WDH2662	6.58 (0.61)	27 1/8" (708)	34 1/4" (870)	11.78 (1.09)	6.65 (0.62)	8 1/2" (215)	16.88 (1.57)
WDH28210	2.90 (0.27)	29 1/8" (759)	14 1/4" (362)	5.23 (0.49)	2.98 (0.28)	48 1/2" (1231)	8.61 (0.80)
WDH2832	3.31 (0.31)	29 1/8" (759)	16 1/4" (412)	5.98 (0.56)	3.39 (0.32)	44 1/2" (1130)	9.54 (0.89)
WDH2836	3.73 (0.35)	29 1/8" (759)	18 1/4" (463)	6.73 (0.63)	3.81 (0.35)	40 1/2" (1028)	10.47 (0.97)
WDH28310	4.14 (0.38)	29 1/8" (759)	20 1/4" (514)	7.48 (0.70)	4.22 (0.39)	36 1/2" (926)	11.41 (1.06)
WDH2842	4.56 (0.42)	29 1/8" (759)	22 1/4" (565)	8.23 (0.77)	4.64 (0.43)	32 1/2" (825)	12.34 (1.15)
WDH2846	4.85 (0.45)	29 1/8" (759)	24 1/4" (616)	8.98 (0.83)	5.05 (0.47)	28 1/2" (723)	13.28 (1.23)
WDH28410	5.38 (0.50)	29 1/8" (759)	26 1/4" (666)	9.73 (0.90)	5.47 (0.51)	24 1/2" (622)	14.21 (1.32)
WDH2852	5.80 (0.54)	29 1/8" (759)	28 1/4" (717)	10.48 (0.97)	5.88 (0.55)	20 1/2" (520)	15.14 (1.41)
WDH2856	6.22 (0.58)	29 1/8" (759)	30 1/4" (768)	11.22 (1.04)	5.05 (0.47)	16 1/2" (418)	16.08 (1.49)
WDH28510	6.63 (0.62)	29 1/8" (759)	32 1/4" (819)	11.97 (1.11)	6.71 (0.62)	12 1/2" (317)	17.01 (1.58)
WDH2862	7.05 (0.66)	29 1/8" (759)	34 1/4" (870)	12.72 (1.18)	7.13 (0.66)	8 1/2" (215)	17.95 (1.67)
WDH210210	3.09 (0.29)	31 1/8" (809)	14 1/4" (362)	5.62 (0.52)	3.18 (0.30)	48 1/2" (1231)	9.12 (0.85)
WDH21032	3.53 (0.33)	31 1/8" (809)	16 1/4" (412)	6.42 (0.60)	3.62 (0.34)	44 1/2" (1130)	10.11 (0.94)
WDH21036	3.97 (0.37)	31 1/8" (809)	18 1/4" (463)	7.23 (0.67)	4.06 (0.38)	40 1/2" (1028)	11.10 (1.03)
WDH210310	4.42 (0.41)	31 1/8" (809)	20 1/4" (514)	8.03 (0.75)	4.51 (0.42)	36 1/2" (926)	12.09 (1.12)
WDH21042	4.86 (0.45)	31 1/8" (809)	22 1/4" (565)	8.84 (0.82)	4.95 (0.46)	32 1/2" (825)	13.08 (1.22)
WDH21046	5.17 (0.48)	31 1/8" (809)	24 1/4" (616)	9.64 (0.90)	5.39 (0.50)	28 1/2" (723)	14.07 (1.31)

For cottage and reverse cottage sash opening specifications, visit [andersenwindows.com/openingspecs](http://andersenwindows.com/openingspecs).

400 Series Woodwright® Double-Hung Full-Frame Windows

\* "Top of Subfloor to Top of Inside Sill Stop" is calculated based upon a structural header height of 6'-10 1/2" (2096).  
• Dimensions in parentheses are in millimeters or square meters.  
Ø Meet or exceed clear opening area of 5.7 sq. ft. or 0.53 m<sup>2</sup>, clear opening width of 20" (508) and clear opening height of 24" (610).

continued on next page

# WOODWRIGHT® DOUBLE-HUNG FULL-FRAME WINDOWS

## Woodwright® Double-Hung Window Opening and Area Specifications *(continued)*

Window Number	Clear Opening Area Sq. Ft./ (m <sup>2</sup> )	Clear Opening in Full Open Position		Glass Area Sq. Ft./ (m <sup>2</sup> )	Vent Area Sq. Ft./ (m <sup>2</sup> )	Top of Subfloor to Top of Inside Sill Stop Inches/(mm)	Overall Window Area Sq. Ft./ (m <sup>2</sup> )
		Width Inches/(mm)	Height Inches/(mm)				
WDH210410 ◊	5.74 (0.53)	31 7/8" (809)	26 1/4" (666)	10.45 (0.97)	5.83 (0.54)	24 1/2" (622)	15.05 (1.40)
WDH21052 ◊	6.18 (0.57)	31 1/8" (809)	28 1/4" (717)	11.25 (1.05)	6.28 (0.58)	20 1/2" (520)	16.04 (1.49)
WDH21056 ◊	6.63 (0.62)	31 7/8" (809)	30 1/4" (768)	12.06 (1.12)	5.39 (0.50)	16 1/2" (418)	17.03 (1.59)
WDH210510 ◊	7.07 (0.66)	31 7/8" (809)	34 1/4" (819)	12.86 (1.20)	7.16 (0.67)	12 1/2" (317)	18.02 (1.67)
WDH21062 ◊	7.52 (0.70)	31 7/8" (809)	34 1/4" (870)	13.67 (1.27)	7.60 (0.71)	8 1/2" (215)	19.01 (1.77)
WDH30210	3.29 (0.31)	33 7/8" (860)	14 1/4" (362)	6.01 (0.56)	3.38 (0.31)	48 1/2" (1231)	9.63 (0.90)
WDH3032	3.75 (0.35)	33 7/8" (860)	16 1/4" (412)	6.87 (0.64)	3.85 (0.36)	44 1/2" (1130)	10.67 (0.99)
WDH3036	4.22 (0.39)	33 7/8" (860)	18 1/4" (463)	7.73 (0.72)	4.32 (0.40)	40 1/2" (1028)	11.72 (1.09)
WDH30310	4.69 (0.44)	33 7/8" (860)	20 1/4" (514)	8.59 (0.80)	4.79 (0.45)	36 1/2" (926)	12.76 (1.19)
WDH3042	5.17 (0.48)	33 7/8" (860)	22 1/4" (565)	9.45 (0.88)	5.26 (0.49)	32 1/2" (825)	13.81 (1.28)
WDH3046 ◊	5.75 (0.53)	33 7/8" (860)	24 1/4" (616)	10.31 (0.96)	5.73 (0.53)	28 1/2" (723)	14.85 (1.38)
WDH30410 ◊	6.10 (0.57)	33 7/8" (860)	26 1/4" (666)	11.17 (1.04)	6.20 (0.58)	24 1/2" (622)	15.90 (1.48)
WDH3052 ◊	6.57 (0.61)	33 7/8" (860)	28 1/4" (717)	12.03 (1.12)	6.67 (0.62)	20 1/2" (520)	16.95 (1.58)
WDH3056 ◊	7.04 (0.65)	33 7/8" (860)	30 1/4" (768)	12.89 (1.20)	5.73 (0.53)	16 1/2" (418)	17.99 (1.67)
WDH30510 ◊	7.52 (0.70)	33 7/8" (860)	32 1/4" (819)	13.75 (1.28)	7.61 (0.71)	12 1/2" (317)	19.04 (1.77)
WDH3062 ◊	7.99 (0.74)	33 7/8" (860)	34 1/4" (870)	14.61 (1.36)	8.08 (0.75)	8 1/2" (215)	20.08 (1.87)
WDH34210	3.68 (0.34)	37 7/8" (962)	14 1/4" (362)	6.79 (0.63)	3.78 (0.35)	48 1/2" (1231)	10.65 (0.99)
WDH3432	4.19 (0.39)	37 7/8" (962)	16 1/4" (412)	7.76 (0.72)	4.30 (0.40)	44 1/2" (1130)	11.81 (1.10)
WDH3436	4.72 (0.44)	37 7/8" (962)	18 1/4" (463)	8.73 (0.81)	4.83 (0.45)	40 1/2" (1028)	12.97 (1.21)
WDH34310	5.25 (0.49)	37 7/8" (962)	20 1/4" (514)	9.70 (0.90)	5.35 (0.50)	36 1/2" (926)	14.12 (1.31)
WDH3442	5.78 (0.54)	37 7/8" (962)	22 1/4" (565)	10.67 (0.99)	5.88 (0.55)	32 1/2" (825)	15.28 (1.42)
WDH3446 ◊	6.14 (0.57)	37 7/8" (962)	24 1/4" (616)	11.64 (1.08)	6.41 (0.60)	28 1/2" (723)	16.43 (1.53)
WDH34410 ◊	6.82 (0.63)	37 7/8" (962)	26 1/4" (666)	12.61 (1.17)	6.93 (0.64)	24 1/2" (622)	17.59 (1.63)
WDH3452 ◊	7.35 (0.68)	37 7/8" (962)	28 1/4" (717)	13.58 (1.26)	7.46 (0.69)	20 1/2" (520)	18.75 (1.74)
WDH3456 ◊	7.88 (0.73)	37 7/8" (962)	30 1/4" (768)	14.55 (1.35)	6.41 (0.60)	16 1/2" (418)	19.90 (1.85)
WDH34510 ◊	8.41 (0.78)	37 7/8" (962)	32 1/4" (819)	15.53 (1.44)	8.51 (0.79)	12 1/2" (317)	21.06 (1.96)
WDH3462 ◊	8.94 (0.83)	37 7/8" (962)	34 1/4" (870)	16.50 (1.53)	9.04 (0.84)	8 1/2" (215)	22.22 (2.06)
WDH38210	4.07 (0.38)	41 7/8" (1064)	14 1/4" (362)	7.56 (0.70)	4.17 (0.39)	48 1/2" (1231)	11.68 (1.09)
WDH3832	4.64 (0.43)	41 7/8" (1064)	16 1/4" (412)	8.64 (0.80)	4.76 (0.44)	44 1/2" (1130)	12.94 (1.20)
WDH3836	5.22 (0.49)	41 7/8" (1064)	18 1/4" (463)	9.72 (0.90)	5.34 (0.50)	40 1/2" (1028)	14.21 (1.32)
WDH38310	5.81 (0.54)	41 7/8" (1064)	20 1/4" (514)	10.81 (1.00)	5.92 (0.55)	36 1/2" (926)	15.48 (1.44)
WDH3842	6.39 (0.59)	41 7/8" (1064)	22 1/4" (565)	11.89 (1.11)	6.50 (0.60)	32 1/2" (825)	16.75 (1.56)
WDH3846 ◊	6.79 (0.63)	41 7/8" (1064)	24 1/4" (616)	12.97 (1.21)	7.08 (0.66)	28 1/2" (723)	18.01 (1.67)
WDH38410 ◊	7.55 (0.70)	41 7/8" (1064)	26 1/4" (666)	14.05 (1.31)	7.66 (0.71)	24 1/2" (622)	19.28 (1.79)
WDH3852 ◊	8.13 (0.76)	41 7/8" (1064)	28 1/4" (717)	15.14 (1.41)	8.25 (0.77)	20 1/2" (520)	20.55 (1.91)
WDH3856 ◊	8.72 (0.81)	41 7/8" (1064)	30 1/4" (768)	16.22 (1.51)	7.08 (0.66)	16 1/2" (418)	21.62 (2.01)
WDH38510 ◊	9.30 (0.86)	41 7/8" (1064)	32 1/4" (819)	17.30 (1.61)	9.41 (0.87)	12 1/2" (317)	23.08 (2.14)
WDH3862 ◊	9.88 (0.92)	41 7/8" (1064)	34 1/4" (870)	18.38 (1.71)	9.99 (0.93)	8 1/2" (215)	24.35 (2.26)

For cottage and reverse cottage sash

opening specifications visit

[andersenwindows.com/openingspecs](http://andersenwindows.com/openingspecs).

## Woodwright® Springline™ Single-Hung Window Opening and Area Specifications

Window Number	Clear Opening Area Sq. Ft./ (m <sup>2</sup> )	Clear Opening in Full Open Position		Glass Area Sq. Ft./ (m <sup>2</sup> )	Vent Area Sq. Ft./ (m <sup>2</sup> )	Top of Subfloor to Top of Inside Sill Stop Inches/(mm)	Overall Window Area Sq. Ft./ (m <sup>2</sup> )
		Width Inches/(mm)	Height Inches/(mm)				
WS2042	1.39 (0.13)	21 7/8" (556)	9 3/16" (231)	5.48 (0.51)	1.39 (0.13)	32 9/16" (828)	8.90 (0.83)
WS2046	1.54 (0.14)	21 7/8" (556)	10 2/16" (257)	5.88 (0.55)	1.54 (0.14)	29 9/16" (751)	9.44 (0.88)
WS20410	1.69 (0.16)	21 7/8" (556)	11 2/16" (282)	6.29 (0.59)	1.69 (0.16)	26 9/16" (675)	9.97 (0.93)
WS2052	1.84 (0.17)	21 7/8" (556)	12 2/16" (308)	6.70 (0.62)	1.84 (0.17)	23 9/16" (599)	10.51 (0.98)
WS2056	2.76 (0.26)	21 7/8" (556)	18 2/16" (461)	7.80 (0.72)	2.76 (0.26)	15 9/16" (395)	11.94 (1.11)
WS20510	2.96 (0.28)	21 7/8" (556)	19 1/2" (495)	8.25 (0.77)	2.96 (0.28)	12 9/16" (310)	12.53 (1.16)
WS2062	3.16 (0.29)	21 7/8" (556)	20 13/16" (529)	8.71 (0.81)	3.16 (0.29)	8 7/8" (226)	13.12 (1.22)
WS2442	1.64 (0.15)	25 7/8" (658)	9 2/16" (231)	6.85 (0.64)	1.64 (0.15)	30 9/16" (777)	10.62 (0.99)
WS2446	1.82 (0.17)	25 7/8" (658)	10 2/16" (257)	7.34 (0.68)	1.82 (0.17)	27 9/16" (701)	11.23 (1.04)
WS24410	2.00 (0.19)	25 7/8" (658)	11 2/16" (282)	7.83 (0.73)	2.00 (0.19)	24 9/16" (624)	11.85 (1.10)
WS2452	2.18 (0.20)	25 7/8" (658)	12 2/16" (308)	8.33 (0.77)	2.18 (0.20)	21 9/16" (548)	12.47 (1.16)
WS2456	3.26 (0.30)	25 7/8" (658)	18 2/16" (461)	9.65 (0.90)	3.26 (0.30)	13 9/16" (344)	14.12 (1.31)
WS24510	3.50 (0.33)	25 7/8" (658)	19 1/2" (495)	10.19 (0.95)	3.50 (0.33)	10 3/16" (259)	14.81 (1.38)
WS2462	3.74 (0.35)	25 7/8" (658)	20 13/16" (529)	10.74 (1.00)	3.74 (0.35)	6 7/8" (175)	15.49 (1.44)
WS2642	1.76 (0.16)	27 7/8" (708)	9 1/8" (231)	7.57 (0.70)	1.76 (0.16)	29 9/16" (751)	11.51 (1.07)
WS2646	1.96 (0.18)	27 7/8" (708)	10 1/8" (257)	8.10 (0.75)	1.96 (0.18)	26 9/16" (675)	12.17 (1.13)
WS26410	2.15 (0.20)	27 7/8" (708)	11 1/8" (282)	8.64 (0.80)	2.15 (0.20)	23 9/16" (599)	12.82 (1.19)
WS2652	2.35 (0.22)	27 7/8" (708)	12 1/8" (308)	9.17 (0.85)	2.35 (0.22)	20 9/16" (523)	13.48 (1.25)
WS2656	3.52 (0.33)	27 7/8" (708)	18 1/8" (461)	10.60 (0.99)	3.52 (0.33)	12 9/16" (319)	15.25 (1.42)

\*Top of Subfloor to Top of Inside Sill Stop" is calculated based upon a structural header height of 6'-10 1/2" (2096).

\*Dimensions in parentheses are in millimeters or square meters.

◊ Meet or exceed clear opening area of 5.7 sq. ft. or 0.53 m<sup>2</sup>, clear opening width of 20" (508) and clear opening height of 24" (610).

*continued on next page*

**Woodwright® Springline™ Single-Hung Window Opening and Area Specifications** *(continued)*

Window Number	Clear Opening Area Sq. Ft./ (m²)	Clear Opening in Full Open Position		Glass Area Sq. Ft./ (m²)	Vent Area Sq. Ft./ (m²)	Top of Subfloor to Top of Inside Sill Stop Inches/(mm)	Overall Window Area Sq. Ft./ (m²)
		Width Inches/(mm)	Height Inches/(mm)				
WS26510	3.77 (0.35)	27 1/8" (708)	19 1/2" (495)	11.19 (1.04)	3.77 (0.35)	9 3/16" (234)	15.98 (1.49)
WS2662	4.03 (0.38)	27 1/8" (708)	20 13/16" (529)	11.79 (1.10)	4.03 (0.38)	5 7/8" (149)	16.71 (1.55)
WS2842	1.89 (0.18)	29 1/8" (759)	9 1/8" (231)	8.31 (0.77)	1.89 (0.18)	28 9/16" (726)	12.42 (1.15)
WS2846	2.10 (0.20)	29 1/8" (759)	10 1/8" (257)	8.89 (0.83)	2.10 (0.20)	25 9/16" (650)	13.12 (1.22)
WS28410	2.31 (0.21)	29 1/8" (759)	11 1/8" (282)	9.46 (0.88)	2.31 (0.21)	22 9/16" (574)	13.82 (1.28)
WS2852	2.51 (0.23)	29 1/8" (759)	12 1/8" (308)	10.04 (0.93)	2.51 (0.23)	19 9/16" (497)	14.52 (1.35)
WS2856	3.77 (0.35)	29 1/8" (759)	18 1/8" (461)	11.58 (1.08)	3.77 (0.35)	11 9/16" (293)	16.40 (1.52)
WS28510	4.04 (0.38)	29 1/8" (759)	19 1/8" (495)	12.22 (1.14)	4.04 (0.38)	8 3/16" (209)	17.18 (1.60)
WS2862	4.32 (0.40)	29 1/8" (759)	20 13/16" (529)	12.86 (1.20)	4.32 (0.40)	4 7/8" (124)	17.95 (1.67)
WS21042	2.02 (0.19)	31 1/8" (810)	9 1/8" (231)	9.07 (0.84)	2.02 (0.19)	27 9/16" (701)	13.35 (1.24)
WS21046	2.24 (0.21)	31 1/8" (810)	10 1/8" (257)	9.69 (0.90)	2.24 (0.21)	24 9/16" (624)	14.09 (1.31)
WS210410	2.46 (0.23)	31 1/8" (810)	11 1/8" (282)	10.31 (0.96)	2.46 (0.23)	21 9/16" (548)	14.84 (1.38)
WS21052	2.68 (0.25)	31 1/8" (810)	12 1/8" (308)	10.93 (1.02)	2.68 (0.25)	18 9/16" (472)	15.58 (1.45)
WS21056	4.02 (0.37)	31 1/8" (810)	18 1/8" (461)	12.58 (1.17)	4.02 (0.37)	10 9/16" (268)	17.57 (1.63)
WS210510	4.32 (0.40)	31 1/8" (810)	19 1/2" (495)	13.27 (1.23)	4.32 (0.40)	7 3/16" (183)	18.39 (1.71)
WS21062	4.61 (0.43)	31 1/8" (810)	20 13/16" (529)	13.95 (1.30)	4.61 (0.43)	3 7/8" (99)	19.22 (1.79)
WS3042	2.14 (0.20)	33 1/8" (861)	9 1/8" (231)	9.86 (0.92)	2.14 (0.20)	26 9/16" (675)	14.31 (1.33)
WS3046	2.38 (0.22)	33 1/8" (861)	10 1/8" (257)	10.52 (1.00)	2.38 (0.22)	23 9/16" (599)	15.09 (1.40)
WS30410	2.62 (0.24)	33 1/8" (861)	11 1/8" (282)	11.18 (1.04)	2.62 (0.24)	20 9/16" (523)	15.87 (1.48)
WS3052	2.85 (0.27)	33 1/8" (861)	12 1/8" (308)	11.84 (1.10)	2.85 (0.27)	17 9/16" (447)	16.66 (1.55)
WS3056	4.27 (0.40)	33 1/8" (861)	18 1/8" (461)	13.60 (1.26)	4.27 (0.40)	9 9/16" (242)	18.76 (1.74)
WS30510	4.59 (0.43)	33 1/8" (861)	19 1/2" (495)	14.33 (1.33)	4.59 (0.43)	6 3/16" (158)	19.63 (1.82)
WS3062	4.90 (0.46)	33 1/8" (861)	20 13/16" (529)	15.07 (1.40)	4.90 (0.46)	2 7/8" (73)	20.50 (1.90)
WS3442	2.40 (0.22)	37 1/8" (962)	9 1/8" (231)	11.50 (1.07)	2.40 (0.22)	24 9/16" (624)	16.28 (1.51)
WS3446	2.66 (0.25)	37 1/8" (962)	10 1/8" (257)	12.24 (1.14)	2.66 (0.25)	21 9/16" (548)	17.15 (1.59)
WS34410	2.92 (0.27)	37 1/8" (962)	11 1/8" (282)	12.98 (1.21)	2.92 (0.27)	18 9/16" (472)	18.02 (1.67)
WS3452	3.19 (0.30)	37 1/8" (962)	12 1/8" (308)	13.72 (1.28)	3.19 (0.30)	15 9/16" (396)	18.88 (1.75)
WS3456	4.78 (0.44)	37 1/8" (962)	18 1/8" (461)	15.71 (1.46)	4.78 (0.44)	7 9/16" (192)	21.21 (1.97)
WS34510	5.13 (0.48)	37 1/8" (962)	19 1/2" (495)	16.54 (1.54)	5.13 (0.48)	4 3/16" (107)	22.17 (2.06)
WS3462	5.48 (0.51)	37 1/8" (962)	20 13/16" (529)	17.36 (1.61)	5.48 (0.51)	7/8" (22)	23.13 (2.15)
WS3842	2.65 (0.25)	41 1/8" (1064)	9 1/8" (231)	13.22 (1.23)	2.65 (0.25)	22 9/16" (574)	18.34 (1.70)
WS3846	2.94 (0.27)	41 1/8" (1064)	10 1/8" (257)	14.04 (1.31)	2.94 (0.27)	19 9/16" (497)	19.29 (1.79)
WS38410	3.23 (0.30)	41 1/8" (1064)	11 1/8" (282)	14.87 (1.38)	3.23 (0.30)	16 9/16" (421)	20.24 (1.88)
WS3852	3.52 (0.33)	41 1/8" (1064)	12 1/8" (308)	15.69 (1.46)	3.52 (0.33)	13 9/16" (345)	21.19 (1.97)
WS3856	5.28 (0.49)	41 1/8" (1064)	18 1/8" (461)	17.91 (1.66)	5.28 (0.49)	5 9/16" (141)	23.74 (2.21)
WS38510	5.67 (0.53)	41 1/8" (1064)	19 1/2" (495)	18.82 (1.75)	5.67 (0.53)	2 3/16" (56)	24.80 (2.30)
WS3862	6.06 (0.56)	41 1/8" (1064)	20 13/16" (529)	19.74 (1.83)	6.06 (0.56)	-1 1/8" (-28)	25.85 (2.40)

**Woodwright® Arch Double-Hung Window Opening and Area Specifications**

Window Number	Clear Opening Area Sq. Ft./ (m²)	Clear Opening in Full Open Position		Glass Area Sq. Ft./ (m²)	Vent Area Sq. Ft./ (m²)	Top of Subfloor to Top of Inside Sill Stop Inches/(mm)	Overall Window Area Sq. Ft./ (m²)
		Width Inches/(mm)	Height Inches/(mm)				
WA18210	1.26 (0.12)	17 7/8" (454)	10 3/16" (259)	2.84 (0.26)	1.61 (0.15)	48 1/2" (1232)	5.39 (0.50)
WA1832	1.51 (0.14)	17 7/8" (454)	12 3/16" (309)	3.27 (0.30)	1.85 (0.17)	44 1/2" (1131)	5.99 (0.56)
WA1836	1.76 (0.16)	17 7/8" (454)	14 3/16" (360)	3.71 (0.34)	2.10 (0.20)	40 1/2" (1029)	6.59 (0.61)
WA18310	2.01 (0.19)	17 7/8" (454)	16 3/16" (411)	4.14 (0.39)	2.35 (0.22)	36 1/2" (928)	7.20 (0.67)
WA1842	2.26 (0.21)	17 7/8" (454)	18 3/16" (462)	4.58 (0.43)	2.60 (0.24)	32 1/2" (826)	7.80 (0.72)
WA1846	2.51 (0.23)	17 7/8" (454)	20 3/16" (513)	5.01 (0.47)	2.85 (0.27)	28 1/2" (724)	8.40 (0.78)
WA18410	2.76 (0.26)	17 7/8" (454)	22 3/16" (563)	5.44 (0.51)	3.10 (0.29)	24 1/2" (623)	9.00 (0.84)
WA1852	3.00 (0.28)	17 7/8" (454)	24 3/16" (614)	5.88 (0.55)	3.35 (0.31)	20 1/2" (521)	9.60 (0.89)
WA1856	3.25 (0.30)	17 7/8" (454)	26 3/16" (665)	6.31 (0.59)	3.59 (0.33)	16 1/2" (420)	10.20 (0.95)
WA18510	3.50 (0.33)	17 7/8" (454)	28 3/16" (716)	6.75 (0.63)	3.84 (0.36)	12 1/2" (318)	10.80 (1.00)
WA1862	3.75 (0.35)	17 7/8" (454)	30 3/16" (767)	7.18 (0.67)	4.09 (0.38)	8 1/2" (216)	11.40 (1.06)
WA2032	1.77 (0.16)	21 7/8" (556)	11 5/8" (296)	4.09 (0.38)	2.24 (0.21)	44 1/2" (1131)	7.07 (0.66)
WA2036	2.07 (0.19)	21 7/8" (556)	13 5/8" (347)	4.63 (0.43)	2.55 (0.24)	40 1/2" (1029)	7.78 (0.72)
WA20310	2.38 (0.22)	21 7/8" (556)	15 5/8" (397)	5.18 (0.48)	2.85 (0.27)	36 1/2" (928)	8.50 (0.79)
WA2042	2.68 (0.25)	21 7/8" (556)	17 5/8" (448)	5.72 (0.53)	3.15 (0.29)	32 1/2" (826)	9.21 (0.86)
WA2046	2.99 (0.28)	21 7/8" (556)	19 5/8" (499)	6.27 (0.58)	3.46 (0.32)	28 1/2" (724)	9.92 (0.92)
WA20410	3.29 (0.31)	21 7/8" (556)	21 5/8" (550)	6.81 (0.63)	3.76 (0.35)	24 1/2" (623)	10.63 (0.99)
WA2052	3.59 (0.33)	21 7/8" (556)	23 5/8" (601)	7.36 (0.68)	4.07 (0.38)	20 1/2" (521)	11.34 (1.05)
WA2056	3.90 (0.36)	21 7/8" (556)	25 5/8" (651)	7.90 (0.73)	4.37 (0.41)	16 1/2" (420)	12.05 (1.12)
WA20510	4.20 (0.39)	21 7/8" (556)	27 5/8" (702)	8.45 (0.79)	4.68 (0.43)	12 1/2" (318)	12.77 (1.19)

**Woodwright® Picture Window Area Specifications**

Window Number	Glass Area Sq. Ft./ (m²)	Overall Window Area Sq. Ft./ (m²)
WPW10310	2.03 (0.19)	4.07 (0.38)
WPW1042	2.22 (0.21)	4.41 (0.41)
WPW1046	2.42 (0.23)	4.74 (0.44)
WPW10410	2.61 (0.24)	5.07 (0.47)
WPW1052	2.81 (0.26)	5.41 (0.50)
WPW1056	3.01 (0.28)	5.74 (0.53)
WPW10510	3.20 (0.30)	6.07 (0.56)
WPW1062	3.40 (0.32)	6.41 (0.60)
WPW30310	9.38 (0.87)	12.77 (1.19)
WPW3042	10.29 (0.96)	13.82 (1.28)
WPW3046	11.19 (1.04)	14.86 (1.38)
WPW30410	12.10 (1.12)	15.91 (1.48)
WPW3052	13.01 (1.21)	16.95 (1.58)
WPW3056	13.92 (1.29)	18.00 (1.67)
WPW30510	14.83 (1.38)	19.04 (1.77)
WPW3062	15.73 (1.46)	20.09 (1.87)
WPW34310	10.53 (0.98)	14.13 (1.31)
WPW3442	11.54 (1.07)	15.28 (1.42)
WPW3446	12.56 (1.17)	16.44 (1.53)
WPW34410	13.58 (1.26)	17.60 (1.64)
WPW3452	14.60 (1.36)	18.75 (1.74)
WPW3456	15.62 (1.45)	19.91 (1.85)
WPW34510	16.64 (1.55)	21.07 (1.96)
WPW3462	17.66 (1.64)	22.22 (2.06)
WPW310310	12.16 (1.13)	16.06 (1.49)
WPW31042	13.33 (1.24)	17.37 (1.61)
WPW31046	14.51 (1.35)	18.69 (1.74)
WPW310410	15.69 (1.46)	20.00 (1.86)
WPW31052	16.87 (1.57)	21.32 (1.98)
WPW31056	18.04 (1.68)	22.63 (2.10)
WPW310510	19.22 (1.79)	23.94 (2.22)
WPW31062	20.40 (1.90)	25.26 (2.35)
WPW42310	13.30 (1.24)	17.42 (1.62)
WPW4242	14.20 (1.32)	18.84 (1.75)
WPW4246	15.88 (1.48)	20.27 (1.88)
WPW42410	17.17 (1.60)	21.69 (2.02)
WPW4252	18.46 (1.72)	23.12 (2.15)
WPW4256	19.75 (1.84)	24.54 (2.28)
WPW42510	21.03 (1.95)	25.97 (2.41)
WPW4262	22.32 (2.07)	27.39 (2.55)
WPW410310	15.60 (1.45)	20.13 (1.87)
WPW41042	17.11 (1.59)	21.78 (2.02)
WPW41046	18.62 (1.73)	23.43 (2.18)
WPW410410	20.13 (1.87)	25.07 (2.33)
WPW41052	21.64 (2.01)	26.72 (2.48)
WPW41056	23.15 (2.15)	28.37 (2.64)
WPW410510	24.66 (2.29)	30.02 (2.79)
WPW41062	26.17 (2.43)	31.66 (2.94)
WPW56310	17.89 (1.66)	22.85 (2.12)
WPW5642	19.63 (1.82)	24.72 (2.30)
WPW5646	21.36 (1.98)	26.59 (2.47)
WPW56410	23.09 (2.15)	28.46 (2.64)
WPW5652	24.83 (2.31)	30.33 (2.82)
WPW5656	26.56 (2.47)	32.20 (2.99)
WPW56510	28.29 (2.63)	34.07 (3.17)
WPW5662	30.02 (2.79)	35.93 (3.34)

\*Dimensions in parentheses are in square meters.

\*"Top of Subfloor to Top of Inside Sill Stop" is calculated based upon a structural header height of 6'-10 1/2" (2096).

\*Dimensions in parentheses are in millimeters or square meters.

400 Series  
Woodwright® Double-Hung  
Full-Frame Windows

# WOODWRIGHT® DOUBLE-HUNG FULL-FRAME WINDOWS

## Woodwright® Arch Double-Hung Window Opening and Area Specifications (continued)

Window Number	Clear Opening Area Sq. Ft./ (m <sup>2</sup> )	Clear Opening in Full Open Position		Glass Area Sq. Ft./ (m <sup>2</sup> )	Vent Area Sq. Ft./ (m <sup>2</sup> )	Top of Subfloor to Top of Inside Sill Stop Inches/(mm)	Overall Window Area Sq. Ft./ (m <sup>2</sup> )
		Width Inches/(mm)	Height Inches/(mm)				
WA2062	4.51 (0.42)	21 7/8" (556)	29 5/8" (753)	8.99 (0.84)	4.98 (0.46)	8 1/2" (216)	13.48 (1.25)
WA2432	2.00 (0.19)	25 1/8" (658)	11 1/8" (282)	4.89 (0.46)	2.62 (0.24)	44 1/2" (1131)	8.14 (0.76)
WA2436	2.36 (0.22)	25 1/8" (658)	13 1/8" (333)	5.55 (0.52)	2.98 (0.28)	40 1/2" (1029)	8.96 (0.83)
WA24310	2.72 (0.25)	25 1/8" (658)	15 1/8" (384)	6.21 (0.58)	3.34 (0.31)	36 1/2" (928)	9.79 (0.91)
WA2442	3.08 (0.29)	25 1/8" (658)	17 1/8" (435)	6.86 (0.64)	3.70 (0.34)	32 1/2" (826)	10.61 (0.99)
WA2446	3.44 (0.32)	25 1/8" (658)	19 1/8" (485)	7.52 (0.70)	4.06 (0.38)	28 1/2" (724)	11.43 (1.06)
WA24410	3.80 (0.35)	25 1/8" (658)	21 1/8" (536)	8.17 (0.76)	4.42 (0.41)	24 1/2" (623)	12.26 (1.14)
WA2452	4.16 (0.39)	25 1/8" (658)	23 1/8" (587)	8.83 (0.82)	4.78 (0.44)	20 1/2" (521)	13.08 (1.22)
WA2456	4.51 (0.42)	25 1/8" (658)	25 1/8" (638)	9.49 (0.88)	5.14 (0.48)	16 1/2" (420)	13.90 (1.29)
WA24510	4.87 (0.45)	25 1/8" (658)	27 1/8" (689)	10.14 (0.94)	5.50 (0.51)	12 1/2" (318)	14.72 (1.37)
WA2462	5.23 (0.49)	25 1/8" (658)	29 1/8" (739)	10.80 (1.00)	5.86 (0.54)	8 1/2" (216)	15.55 (1.44)
WA2632	2.10 (0.20)	27 7/8" (708)	10 13/16" (275)	5.29 (0.49)	2.81 (0.26)	44 1/2" (1131)	8.67 (0.81)
WA2636	2.49 (0.23)	27 7/8" (708)	12 13/16" (326)	6.00 (0.56)	3.19 (0.30)	40 1/2" (1029)	9.55 (0.89)
WA26310	2.88 (0.27)	27 7/8" (708)	14 13/16" (377)	6.72 (0.62)	3.58 (0.33)	36 1/2" (928)	10.43 (0.97)
WA2642	3.26 (0.30)	27 7/8" (708)	16 13/16" (428)	7.43 (0.69)	3.97 (0.37)	32 1/2" (826)	11.31 (1.05)
WA2646	3.65 (0.34)	27 7/8" (708)	18 13/16" (479)	8.14 (0.76)	4.36 (0.41)	28 1/2" (724)	12.18 (1.13)
WA26410	4.04 (0.38)	27 7/8" (708)	20 13/16" (529)	8.85 (0.82)	4.74 (0.44)	24 1/2" (623)	13.06 (1.21)
WA2652	4.42 (0.41)	27 7/8" (708)	22 13/16" (580)	9.56 (0.89)	5.13 (0.48)	20 1/2" (521)	13.94 (1.30)
WA2656	4.81 (0.45)	27 7/8" (708)	24 13/16" (631)	10.28 (0.96)	5.52 (0.51)	16 1/2" (420)	14.82 (1.38)
WA26510	5.20 (0.48)	27 7/8" (708)	26 13/16" (682)	10.99 (1.02)	5.91 (0.55)	12 1/2" (318)	15.70 (1.46)
WA2662	5.59 (0.52)	27 7/8" (708)	28 13/16" (733)	11.70 (1.09)	6.29 (0.59)	8 1/2" (216)	16.58 (1.54)
WA2836	2.61 (0.24)	29 1/8" (759)	12 9/16" (319)	6.46 (0.60)	3.41 (0.32)	40 1/2" (1029)	10.13 (0.94)
WA28310	3.03 (0.28)	29 1/8" (759)	14 9/16" (370)	7.22 (0.67)	3.82 (0.36)	36 1/2" (928)	11.07 (1.03)
WA2842	3.44 (0.32)	29 1/8" (759)	16 9/16" (421)	7.99 (0.74)	4.24 (0.39)	32 1/2" (826)	12.00 (1.12)
WA2846	3.86 (0.36)	29 1/8" (759)	18 9/16" (472)	8.76 (0.81)	4.65 (0.43)	28 1/2" (724)	12.94 (1.20)
WA28410	4.27 (0.40)	29 1/8" (759)	20 9/16" (523)	9.53 (0.89)	5.07 (0.47)	24 1/2" (623)	13.87 (1.29)
WA2852	4.69 (0.44)	29 1/8" (759)	22 9/16" (573)	10.29 (0.96)	5.48 (0.51)	20 1/2" (521)	14.80 (1.38)
WA2856	5.10 (0.47)	29 1/8" (759)	24 9/16" (624)	11.06 (1.03)	5.90 (0.55)	16 1/2" (420)	15.74 (1.46)
WA28510	5.52 (0.51)	29 1/8" (759)	26 9/16" (675)	11.83 (1.10)	6.31 (0.59)	12 1/2" (318)	16.67 (1.55)
WA2862 ◊	5.93 (0.55)	29 1/8" (759)	28 9/16" (726)	12.60 (1.17)	6.73 (0.63)	8 1/2" (216)	17.61 (1.64)
WA210310	3.17 (0.29)	31 1/8" (810)	14 5/16" (363)	7.73 (0.72)	4.06 (0.38)	36 1/2" (928)	11.70 (1.09)
WA21042	3.61 (0.34)	31 1/8" (810)	16 5/16" (414)	8.55 (0.80)	4.50 (0.42)	32 1/2" (826)	12.69 (1.18)
WA21046	4.05 (0.38)	31 1/8" (810)	18 5/16" (465)	9.38 (0.87)	4.94 (0.46)	28 1/2" (724)	13.68 (1.27)
WA210410	4.50 (0.42)	31 1/8" (810)	20 5/16" (516)	10.20 (0.95)	5.39 (0.50)	24 1/2" (623)	14.67 (1.36)
WA21052	4.94 (0.46)	31 1/8" (810)	22 5/16" (567)	11.02 (1.02)	5.83 (0.54)	20 1/2" (521)	15.66 (1.46)
WA21056	5.38 (0.50)	31 1/8" (810)	24 5/16" (617)	11.84 (1.10)	6.27 (0.58)	16 1/2" (420)	16.65 (1.55)
WA210510 ◊	5.83 (0.54)	31 1/8" (810)	26 5/16" (668)	12.67 (1.18)	6.72 (0.62)	12 1/2" (318)	17.64 (1.64)
WA21062 ◊	6.27 (0.58)	31 1/8" (810)	28 5/16" (719)	13.49 (1.25)	7.16 (0.67)	8 1/2" (216)	18.63 (1.73)
WA30310	3.30 (0.31)	33 1/8" (861)	14 1/16" (357)	8.23 (0.77)	4.29 (0.40)	36 1/2" (928)	12.34 (1.15)
WA3042	3.78 (0.35)	33 1/8" (861)	16 1/16" (407)	9.11 (0.85)	4.76 (0.44)	32 1/2" (826)	13.38 (1.24)
WA3046	4.25 (0.39)	33 1/8" (861)	18 1/16" (458)	9.99 (0.93)	5.23 (0.49)	28 1/2" (724)	14.43 (1.34)
WA30410	4.72 (0.44)	33 1/8" (861)	20 1/16" (509)	10.87 (1.01)	5.70 (0.53)	24 1/2" (623)	15.47 (1.44)
WA3052	5.19 (0.48)	33 1/8" (861)	22 1/16" (560)	11.75 (1.09)	6.17 (0.57)	20 1/2" (521)	16.52 (1.54)
WA3056	5.66 (0.53)	33 1/8" (861)	24 1/16" (611)	12.62 (1.17)	6.65 (0.62)	16 1/2" (420)	17.56 (1.63)
WA30510 ◊	6.13 (0.57)	33 1/8" (861)	26 1/16" (661)	13.50 (1.25)	7.12 (0.66)	12 1/2" (318)	18.61 (1.73)
WA3062 ◊	6.60 (0.61)	33 1/8" (861)	28 1/16" (712)	14.38 (1.34)	7.59 (0.71)	8 1/2" (216)	19.65 (1.83)
WA34310	3.55 (0.33)	37 7/8" (962)	13 1/2" (343)	9.23 (0.86)	4.75 (0.44)	36 1/2" (928)	13.60 (1.26)
WA3442	4.08 (0.38)	37 7/8" (962)	15 1/2" (394)	10.22 (0.95)	5.28 (0.49)	32 1/2" (826)	14.76 (1.37)
WA3446	4.61 (0.43)	37 7/8" (962)	17 1/2" (445)	11.21 (1.04)	5.81 (0.54)	28 1/2" (724)	15.91 (1.48)
WA34410	5.13 (0.48)	37 7/8" (962)	19 1/2" (495)	12.20 (1.13)	6.33 (0.59)	24 1/2" (623)	17.07 (1.59)
WA3452	5.66 (0.53)	37 7/8" (962)	21 1/2" (546)	13.19 (1.23)	6.86 (0.64)	20 1/2" (521)	18.22 (1.69)
WA3456	6.19 (0.58)	37 7/8" (962)	23 1/2" (597)	14.18 (1.32)	7.38 (0.69)	16 1/2" (420)	19.38 (1.80)
WA34510 ◊	6.71 (0.62)	37 7/8" (962)	25 1/2" (648)	15.17 (1.41)	7.91 (0.74)	12 1/2" (318)	20.54 (1.91)
WA3462 ◊	7.24 (0.67)	37 7/8" (962)	27 1/2" (699)	16.16 (1.50)	8.44 (0.78)	8 1/2" (216)	21.69 (2.02)
WA3842	4.36 (0.41)	41 7/8" (1064)	15" (380)	11.32 (1.05)	5.79 (0.54)	32 1/2" (826)	16.12 (1.50)
WA3846	4.94 (0.46)	41 7/8" (1064)	17" (431)	12.42 (1.15)	6.37 (0.59)	28 1/2" (724)	17.39 (1.62)
WA38410	5.52 (0.51)	41 7/8" (1064)	19" (482)	13.52 (1.26)	6.95 (0.65)	24 1/2" (623)	18.65 (1.73)
WA3852	6.10 (0.57)	41 7/8" (1064)	21" (533)	14.62 (1.36)	7.53 (0.70)	20 1/2" (521)	19.92 (1.85)
WA3856	6.68 (0.62)	41 7/8" (1064)	23" (583)	15.72 (1.46)	8.11 (0.75)	16 1/2" (420)	21.19 (1.97)
WA38510 ◊	7.26 (0.68)	41 7/8" (1064)	25" (634)	16.82 (1.56)	8.70 (0.81)	12 1/2" (318)	22.46 (2.09)
WA3862 ◊	7.85 (0.73)	41 7/8" (1064)	27" (685)	17.93 (1.67)	9.28 (0.86)	8 1/2" (216)	23.72 (2.20)

\* "Top of Subfloor to Top of Inside Sill Stop" is calculated based upon a structural header height of 6'-10 1/2" (2096).  
 \* Dimensions in parentheses are in millimeters or square meters.  
 ◊ Meet or exceed clear opening area of 5.7 sq. ft. or 0.53 m<sup>2</sup>; clear opening width of 20" (508) and clear opening height of 24" (610).

**Woodwright® Unequal Leg Arch Double-Hung Window Opening and Area Specifications**

Window Number	Clear Opening Area Sq. Ft./ (m <sup>2</sup> )	Clear Opening in Full Open Position		Glass Area Sq. Ft./ (m <sup>2</sup> )	Vent Area Sq. Ft./ (m <sup>2</sup> )	Top of Subfloor to Top of Inside Sill Stop Inches/(mm)	Overall Window Area Sq. Ft./ (m <sup>2</sup> )
		Width Inches/(mm)	Height Inches/(mm)				
WU1836	1.44 (0.13)	17 7/8" (454)	11 5/8" (295)	3.59 (0.33)	1.98 (0.18)	40 1/2" (1029)	6.47 (0.60)
WU18310	1.69 (0.16)	17 7/8" (454)	13 5/8" (346)	4.02 (0.37)	2.23 (0.21)	36 1/2" (928)	7.07 (0.66)
WU1842	1.94 (0.18)	17 7/8" (454)	15 5/8" (396)	4.46 (0.41)	2.48 (0.23)	32 1/2" (826)	7.67 (0.71)
WU1846	2.19 (0.20)	17 7/8" (454)	17 5/8" (447)	4.89 (0.45)	2.72 (0.25)	28 1/2" (724)	8.27 (0.77)
WU18410	2.44 (0.23)	17 7/8" (454)	19 5/8" (498)	5.32 (0.49)	2.97 (0.28)	24 1/2" (623)	8.87 (0.82)
WU1852	2.68 (0.25)	17 7/8" (454)	21 5/8" (549)	5.76 (0.53)	3.22 (0.30)	20 1/2" (521)	9.47 (0.88)
WU1856	2.93 (0.27)	17 7/8" (454)	23 5/8" (600)	6.19 (0.58)	3.47 (0.32)	16 1/2" (420)	10.07 (0.94)
WU18510	3.18 (0.30)	17 7/8" (454)	25 5/8" (650)	6.63 (0.62)	3.72 (0.35)	12 1/2" (318)	10.67 (0.99)
WU1862	3.43 (0.32)	17 7/8" (454)	27 5/8" (701)	7.06 (0.66)	3.97 (0.37)	8 1/2" (216)	11.28 (1.05)
WU20310	1.71 (0.16)	21 1/8" (556)	11 1/4" (286)	4.95 (0.46)	2.61 (0.24)	36 1/2" (928)	8.24 (0.77)
WU2042	2.02 (0.19)	21 1/8" (556)	13 1/4" (337)	5.50 (0.51)	2.91 (0.27)	32 1/2" (826)	8.96 (0.83)
WU2046	2.32 (0.22)	21 1/8" (556)	15 1/4" (388)	6.04 (0.56)	3.22 (0.30)	28 1/2" (724)	9.67 (0.90)
WU20410	2.62 (0.24)	21 1/8" (556)	17 1/4" (438)	6.59 (0.61)	3.52 (0.33)	24 1/2" (623)	10.38 (0.96)
WU2052	2.93 (0.27)	21 1/8" (556)	19 1/4" (489)	7.13 (0.66)	3.83 (0.36)	20 1/2" (521)	11.09 (1.03)
WU2056	3.23 (0.30)	21 1/8" (556)	21 1/4" (540)	7.68 (0.71)	4.13 (0.38)	16 1/2" (420)	11.80 (1.10)
WU20510	3.54 (0.33)	21 1/8" (556)	23 1/4" (591)	8.22 (0.76)	4.44 (0.41)	12 1/2" (318)	12.51 (1.16)
WU2062	3.84 (0.36)	21 1/8" (556)	25 1/4" (642)	8.77 (0.81)	4.74 (0.44)	8 1/2" (216)	13.23 (1.23)
WU2446	2.21 (0.21)	25 1/8" (658)	12 1/4" (312)	7.12 (0.66)	3.64 (0.34)	28 1/2" (724)	10.99 (1.02)
WU24410	2.57 (0.24)	25 1/8" (658)	14 1/4" (363)	7.78 (0.72)	4.00 (0.37)	24 1/2" (623)	11.81 (1.10)
WU2452	2.93 (0.27)	25 1/8" (658)	16 1/4" (413)	8.44 (0.78)	4.36 (0.41)	20 1/2" (521)	12.63 (1.17)
WU2456E	3.29 (0.31)	25 1/8" (658)	18 1/4" (464)	9.09 (0.84)	4.72 (0.44)	16 1/2" (420)	13.46 (1.25)
WU24510	3.65 (0.34)	25 1/8" (658)	20 1/4" (515)	9.75 (0.91)	5.08 (0.47)	12 1/2" (318)	14.28 (1.33)
WU2462	4.01 (0.37)	25 1/8" (658)	22 1/4" (566)	10.40 (0.97)	5.44 (0.51)	8 1/2" (216)	15.10 (1.40)
WU26410	2.42 (0.23)	27 1/8" (708)	12 1/2" (318)	8.34 (0.78)	4.21 (0.39)	24 1/2" (623)	12.49 (1.16)
WU2652	2.81 (0.26)	27 1/8" (708)	14 1/2" (368)	9.06 (0.84)	4.59 (0.43)	20 1/2" (521)	13.37 (1.24)
WU2656	3.20 (0.30)	27 1/8" (708)	16 1/2" (419)	9.77 (0.91)	4.98 (0.46)	16 1/2" (420)	14.25 (1.32)
WU26510	3.58 (0.33)	27 1/8" (708)	18 1/2" (470)	10.48 (0.97)	5.37 (0.50)	12 1/2" (318)	15.13 (1.41)
WU2662	3.97 (0.37)	27 1/8" (708)	20 1/2" (521)	11.19 (1.04)	5.76 (0.53)	8 1/2" (216)	16.01 (1.49)
WU2852	2.59 (0.24)	29 1/8" (759)	12 1/2" (317)	9.65 (0.90)	4.80 (0.45)	20 1/2" (521)	14.08 (1.31)
WU2856	3.01 (0.28)	29 1/8" (759)	14 1/2" (368)	10.42 (0.97)	5.22 (0.48)	16 1/2" (420)	15.01 (1.40)
WU28510	3.42 (0.32)	29 1/8" (759)	16 1/2" (419)	11.19 (1.04)	5.63 (0.52)	12 1/2" (318)	15.95 (1.48)
WU2862	3.84 (0.36)	29 1/8" (759)	18 1/2" (470)	11.95 (1.11)	6.05 (0.56)	8 1/2" (216)	16.88 (1.57)
WU21042	3.13 (0.29)	31 1/8" (810)	14 1/8" (359)	8.35 (0.78)	4.31 (0.40)	32 1/2" (826)	12.52 (1.16)
WU21046	3.57 (0.33)	31 1/8" (810)	16 1/8" (409)	9.17 (0.85)	4.75 (0.44)	28 1/2" (724)	13.51 (1.26)
WU210410	4.01 (0.37)	31 1/8" (810)	18 1/8" (460)	10.00 (0.93)	5.19 (0.48)	24 1/2" (623)	14.50 (1.35)
WU21052	4.46 (0.41)	31 1/8" (810)	20 1/8" (511)	10.82 (1.01)	5.64 (0.52)	20 1/2" (521)	15.49 (1.44)
WU21056	4.90 (0.46)	31 1/8" (810)	22 1/8" (562)	11.64 (1.08)	6.08 (0.56)	16 1/2" (420)	16.48 (1.53)
WU210510	5.34 (0.50)	31 1/8" (810)	24 1/8" (613)	12.46 (1.16)	6.52 (0.61)	12 1/2" (318)	17.47 (1.62)
WU21062 ◊	5.78 (0.54)	31 1/8" (810)	26 1/8" (663)	13.29 (1.23)	6.96 (0.65)	8 1/2" (216)	18.46 (1.72)
WU3042	3.13 (0.29)	33 1/8" (861)	13 5/16" (338)	8.86 (0.82)	4.51 (0.42)	32 1/2" (826)	13.15 (1.22)
WU3046	3.60 (0.34)	33 1/8" (861)	15 5/16" (389)	9.73 (0.90)	4.98 (0.46)	28 1/2" (724)	14.20 (1.32)
WU30410	4.07 (0.38)	33 1/8" (861)	17 5/16" (440)	10.61 (0.99)	5.46 (0.51)	24 1/2" (623)	15.24 (1.42)
WU3052	4.54 (0.42)	33 1/8" (861)	19 5/16" (490)	11.49 (1.07)	5.93 (0.55)	20 1/2" (521)	16.29 (1.51)
WU3056	5.02 (0.47)	33 1/8" (861)	21 5/16" (541)	12.37 (1.15)	6.40 (0.59)	16 1/2" (420)	17.33 (1.61)
WU30510	5.49 (0.51)	33 1/8" (861)	23 5/16" (592)	13.25 (1.23)	6.87 (0.64)	12 1/2" (318)	18.38 (1.71)
WU3062 ◊	5.96 (0.55)	33 1/8" (861)	25 5/16" (643)	14.13 (1.31)	7.34 (0.68)	8 1/2" (216)	19.42 (1.80)
WU34410	4.09 (0.38)	37 1/8" (962)	15 1/2" (395)	11.81 (1.10)	5.95 (0.55)	24 1/2" (623)	16.69 (1.55)
WU3452	4.61 (0.43)	37 1/8" (962)	17 1/2" (445)	12.80 (1.19)	6.47 (0.60)	20 1/2" (521)	17.85 (1.66)
WU3456	5.14 (0.48)	37 1/8" (962)	19 1/2" (496)	13.79 (1.28)	7.00 (0.65)	16 1/2" (420)	19.01 (1.77)
WU34510	5.67 (0.53)	37 1/8" (962)	21 1/2" (547)	14.78 (1.37)	7.53 (0.70)	12 1/2" (318)	20.16 (1.87)
WU3462	6.19 (0.58)	37 1/8" (962)	23 1/2" (598)	15.77 (1.47)	8.05 (0.75)	8 1/2" (216)	21.32 (1.98)
WU3852	4.52 (0.42)	41 1/8" (1064)	15 1/2" (394)	14.06 (1.31)	6.97 (0.65)	20 1/2" (521)	19.36 (1.80)
WU3856	5.10 (0.47)	41 1/8" (1064)	17 1/2" (445)	15.16 (1.41)	7.55 (0.70)	16 1/2" (420)	20.63 (1.92)
WU38510	5.68 (0.53)	41 1/8" (1064)	19 1/2" (496)	16.27 (1.51)	8.13 (0.76)	12 1/2" (318)	21.90 (2.03)
WU3862	6.26 (0.58)	41 1/8" (1064)	21 1/2" (547)	17.37 (1.61)	8.71 (0.81)	8 1/2" (216)	23.16 (2.15)

\*Top of Subfloor to Top of Inside Sill Stop" is calculated based upon a structural header height of 6'-10 1/2" (2096).  
 • Dimensions in parentheses are in millimeters or square meters.  
 ◊ Meet or exceed clear opening area of 5.7 sq. ft. or 0.53 m<sup>2</sup>, clear opening width of 20" (508) and clear opening height of 24" (610).

400 Series  
Woodwright® Double-Hung  
Full-Frame Windows

# WOODWRIGHT® DOUBLE-HUNG FULL-FRAME WINDOWS

## Custom Sizes and Specification Formulas



Available in 1/8" (3) increments between minimum and maximum widths and heights. Windows can also be custom sized to match standard sizes ending in a sixteenth of an inch. Some restrictions apply, contact your Andersen supplier. Measurement guide for custom-size windows can be found at [andersenwindows.com/measure](http://andersenwindows.com/measure).

### Woodwright® Double-Hung Windows

#### Equal

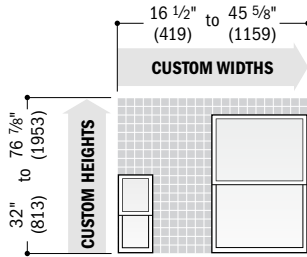

#### 2:3 Cottage

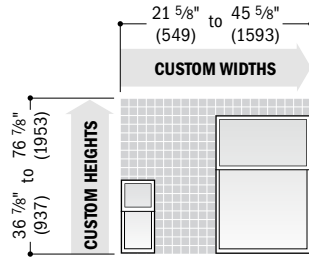

#### 3:2 Reverse Cottage

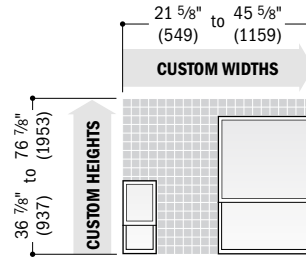

### Woodwright® Picture Windows

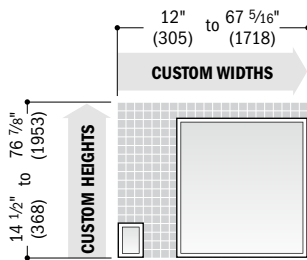

### Woodwright® Transom Windows

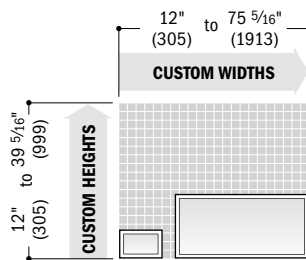

### Woodwright® Springline™ Single-Hung Windows

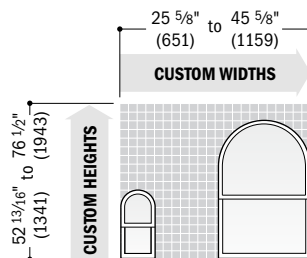

Side-by-side joining of two arch or Springline™ windows or short side joining of unequal leg arch windows is not recommended.

### Woodwright® Arch Double-Hung Windows

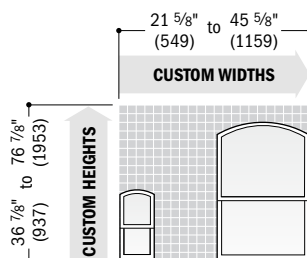

### Woodwright® Unequal Leg Arch Double-Hung Windows

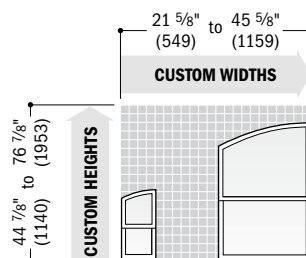

\* Dimensions in parentheses are in millimeters.

**Grille Patterns**

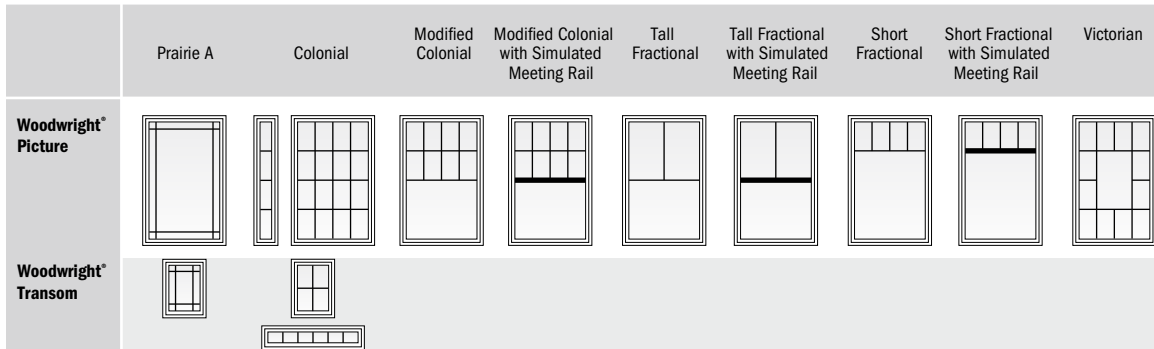
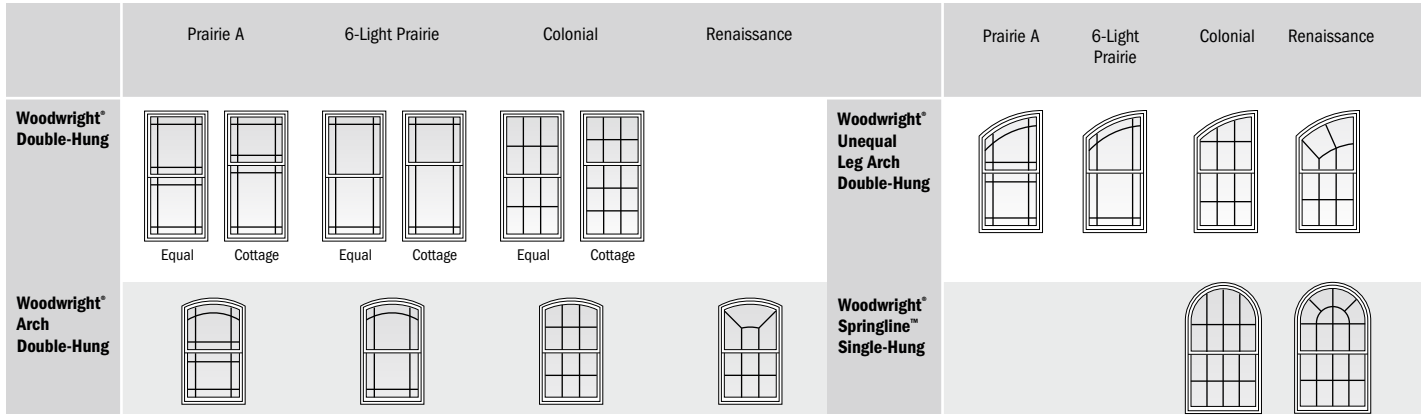

Patterns for double- and single-hung windows are also available in Upper Sash Only (USO) configurations. For picture window patterns that require alignment with double- or single-hung window patterns, identify the sash style (equal, cottage or reverse cottage) when ordering. **Number of lights and overall pattern varies with window size. Patterns are not available in all configurations.**

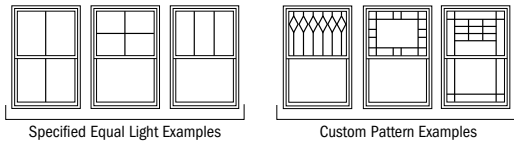

Specified equal light and custom patterns are also available. For more grille options, see page 13 or visit [andersenwindows.com/grilles](http://andersenwindows.com/grilles).

400 Series  
Woodwright® Double-Hung  
Full-Frame Windows

**Woodwright® Transom Window Details**

Scale 1 1/2" (38) = 1'-0" (305) – 1:8

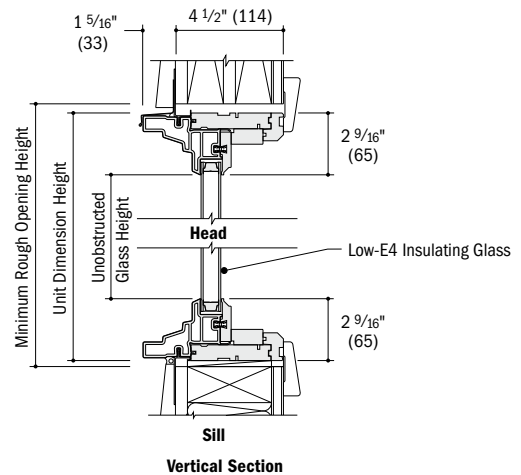
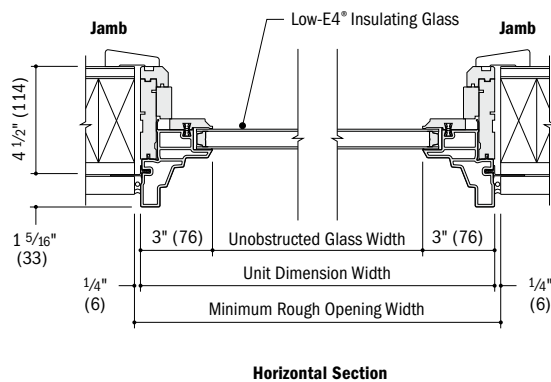

\* Rough openings may need to be increased to allow for use of building wraps, flashing, sill panning, brackets, fasteners or other items. See installation information on pages 210-211.  
 • Details are for illustration only and are not intended to represent product installation methods or materials. Refer to product installation guides at [andersenwindows.com](http://andersenwindows.com).  
 • Dimensions in parentheses are in millimeters.

# WOODWRIGHT® DOUBLE-HUNG FULL-FRAME WINDOWS

## Woodwright® Double-Hung Window Details

Scale 1 1/2" (38) = 1'-0" (305) – 1:8

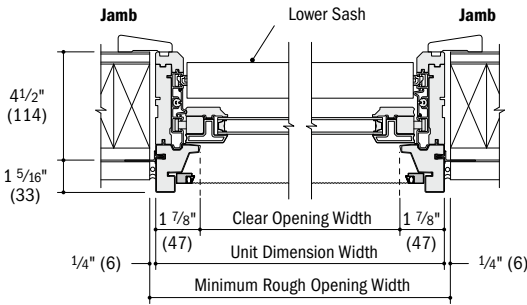

Horizontal Section

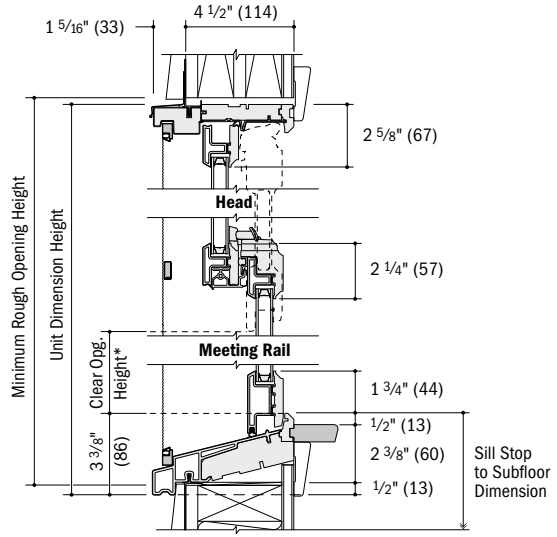

Vertical Section

## Woodwright® Picture Window Details

Scale 1 1/2" (38) = 1'-0" (305) – 1:8

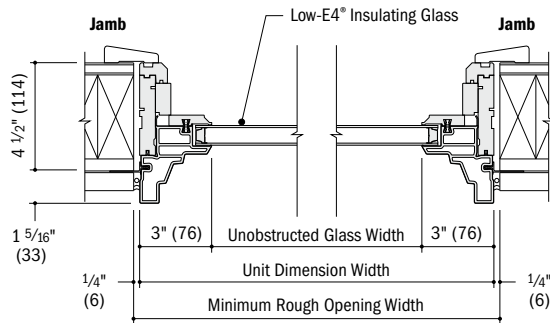

Horizontal Section

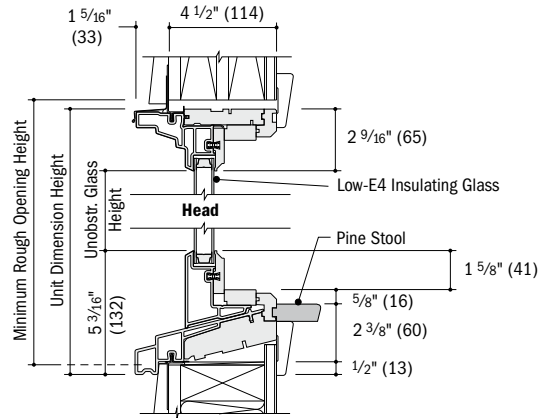

Vertical Section

\* Light-colored areas are parts included with window. Dark-colored areas are additional Andersen® parts required to complete window assembly as shown.

\* **Rough openings may need to be increased to allow for use of building wraps, flashing, sill panning, brackets, fasteners or other items. See installation information on pages 210-211.**

\* Details are for illustration only and are not intended to represent product installation methods or materials. Refer to product installation guides at andersenwindows.com.

\* Dimensions in parentheses are in millimeters.

\* Clear opening height dimension is less on arch, unequal leg arch and Springline™ hung windows.

### Horizontal (stack) Joining Detail

Scale 1½" (38) = 1'-0" (305) – 1:8

#### Overall Window Dimension Height

Sum of individual window heights plus ¼" (1.5) for each join.

#### Overall Rough Opening Height

Overall window dimension height.\*

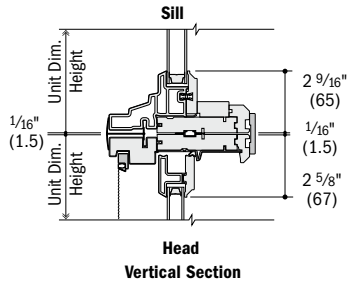

Woodwright® Transom (WTR) over Woodwright Double-Hung

### Vertical (ribbon) Joining Detail

Scale 1½" (38) = 1'-0" (305) – 1:8

#### Overall Window Dimension Width

Sum of individual window widths plus ¼" (1.5) for each join.

#### Overall Rough Opening Width

Overall window dimension width plus ½" (13).

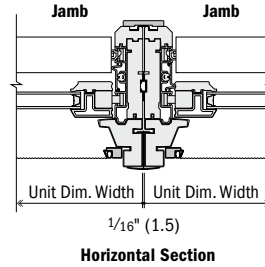

Woodwright Double-Hung to Woodwright Double-Hung

For more joining information, see the combination designs section starting on page 181.

### Separate Rough Openings Detail

Scale 1½" (38) = 1'-0" (305) – 1:8

To meet structural requirements or to achieve a wider joined appearance, windows may be installed into separate rough openings having vertical support (by others) in combination with Andersen® exterior filler and exterior vinyl trim.

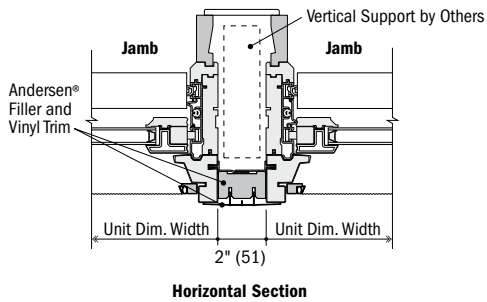

Woodwright Double-Hung and Woodwright Double-Hung

\* Light-colored areas are parts included with window. Dark-colored areas are additional Andersen® parts required to complete window assembly as shown.  
 • **Rough openings may need to be increased to allow for use of building wraps, flashing, sill panning, brackets, fasteners or other items. See installation information on pages 210-211.**  
 • Details are for illustration only and are not intended to represent product installation methods or materials. Refer to product installation guides at andersenwindows.com.  
 • Consult with an architect or structural engineer regarding minimum requirements for structural support members between adjacent rough openings.  
 • Dimensions in parentheses are in millimeters.  
 \*For stacks where bottom unit in combination is a double-hung or picture window with a sloped sill. If bottom window has a straight sill, add ½" (13) to the overall window dimension height.

# NOTES

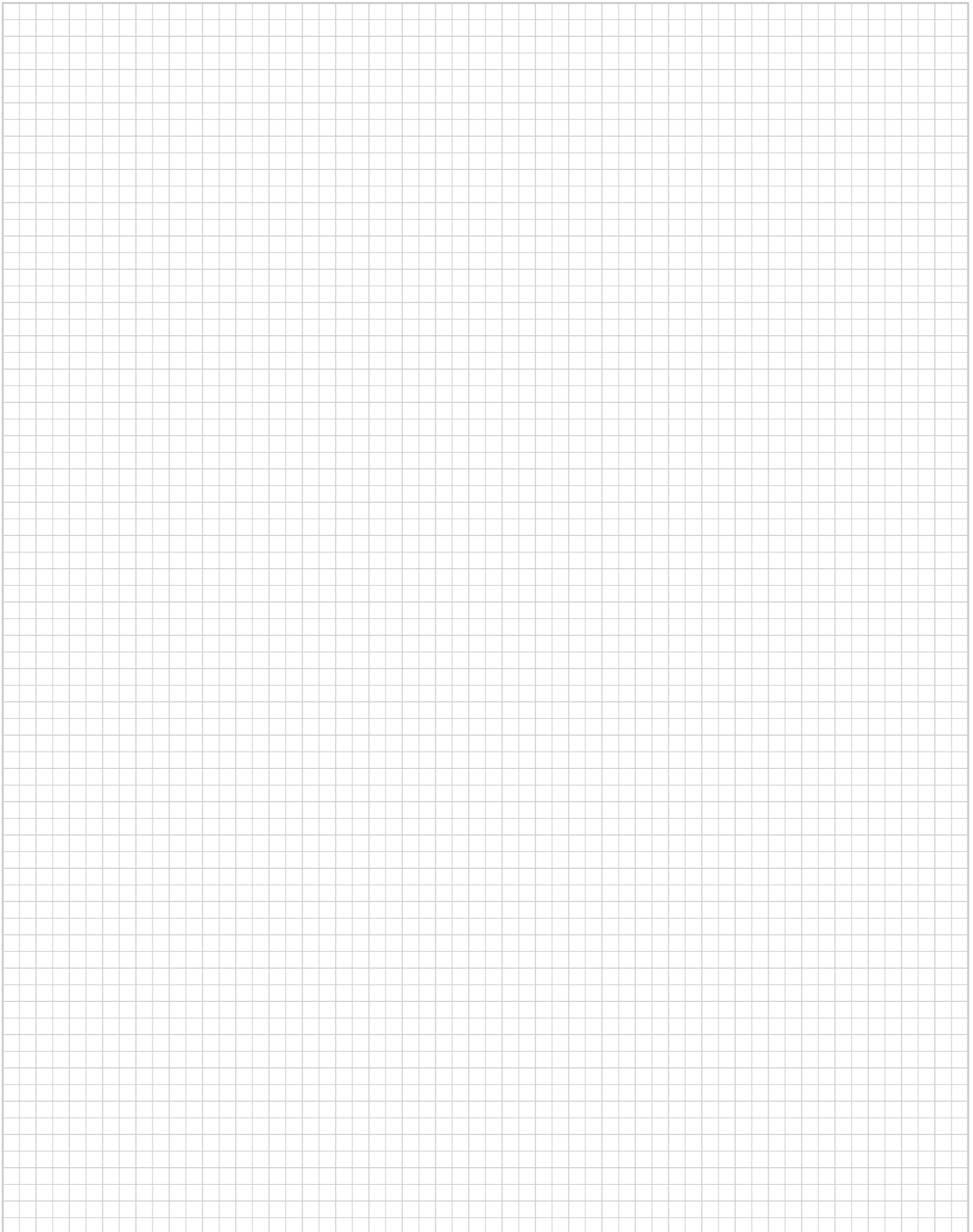

# WOODWRIGHT<sup>®</sup> DOUBLE-HUNG INSERT WINDOWS

400 Series  
Woodwright<sup>®</sup> Double-Hung  
Insert Windows

## SECTION REFERENCE

Custom Sizing .....	70
Specifications .....	70
Existing Window Measurements ...	71
Sill Angle Details .....	71
Grille Patterns .....	72
Window Details .....	72-73
Joining Detail .....	73
Product Performance.....	194

**CUSTOM SIZING**  
in 1/8" (3) increments



Dimensions in parentheses are in millimeters.

# WOODWRIGHT® DOUBLE-HUNG INSERT WINDOWS

## FEATURES

### Frame

**A** Fibrex® material exterior protects the frame – beautifully. Best of all, it's low maintenance and never needs painting.\*

**B** For exceptional long-lasting performance, sill members are constructed with a wood core and a Fibrex material exterior.

**C** Natural wood stops are available in pine, oak, maple and prefinished white. Wood jamb liners add beauty and authenticity to the window interior.

**D** Multiple weatherstrip systems help provide a barrier against wind, rain and dust. The combination of spring tension vinyl, rigid vinyl and flexible bulb weatherstrip is efficient and effective.

**E** Exterior stop covers are specially designed to allow easy application of high-quality sealant.

3 1/4" (83) "pocket window" jamb depth allows convenient replacement without disturbing interior window trim for most double-hung replacement situations.

**F** For units with white exterior color, exterior jamb liner is white. For all other units, the exterior jamb liner is gray.

### Sash

**G** Balancers in the sash enable contractors to screw through the jamb during installation without interfering with the window's operation.

### Wood Jamb Liner



**H** Natural wood sash interior with classic chamfer detailing. Available in pine, oak, maple or prefinished white.

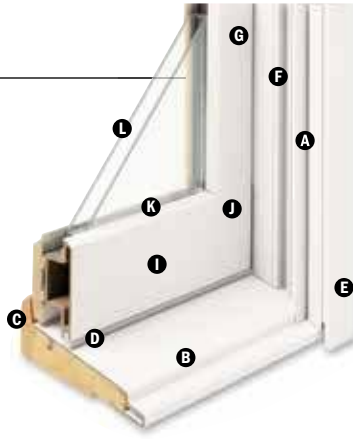

**I** Low-maintenance sash exterior provides long-lasting protection and performance. Sash exteriors on most units include Fibrex material.

**J** Sash joints simulate the look of traditional mortise-and-tenon construction inside and out.

### Glass

**K** Silicone bed glazing provides superior weathertightness and durability.

**L** High-Performance glass options include:

- Low-E4® glass
- Low-E4 HeatLock® glass
- Low-E4 Sun glass
- Low-E4 SmartSun™ glass
- Low-E4 SmartSunHeatLock glass

Tempered glass and other glass options are available. Contact your Andersen supplier.

A removable translucent film helps shield the glass from damage during delivery and construction and simplifies finishing at the jobsite.

### Patterned Glass

Patterned glass options are available. See page 12 for more details.

### Hardware



Standard lock and keeper design provides an easy tilt-to-clean feature integrated into the lock.

## EXTERIOR



## INTERIOR

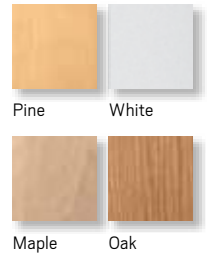

Naturally occurring variations in grain, color and texture of wood make each window one-of-a-kind. All wood interiors are unfinished unless prefinished white is specified.

## HARDWARE FINISHES



Distressed bronze and oil rubbed bronze are "living" finishes that will change with time and use.

## DOUBLE-HUNG HARDWARE

### STANDARD

Lock & Keeper



Antique Brass | **Black** | Bright Brass  
Brushed Chrome | Distressed Bronze  
Distressed Nickel | Gold Dust | Oil Rubbed Bronze  
Polished Chrome | Satin Nickel | Stone | White

## OPTIONAL DOUBLE-HUNG HARDWARE\*\*

### TRADITIONAL



### CLASSIC SERIES™



### CONTEMPORARY



### ESTATE™

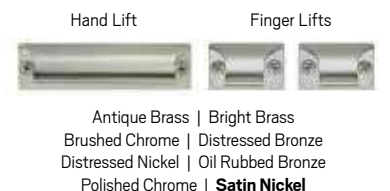

Bold name denotes finish shown.

\* Visit [andersenwindows.com/warranty](http://andersenwindows.com/warranty) for details.

\*\* Hardware sold separately.

Dimensions in parentheses are in millimeters.

Printing limitations prevent exact replication of colors and finishes.

See your Andersen supplier for actual color and finish samples.

### Sill Angles

Three sill angles are available — 0°, 8° and 14° — to closely match the existing sill in window replacement applications. See page 71 for details.



0° Sill Angle



8° Sill Angle



14° Sill Angle

### Sill Angle Finder App

Our Sill Angle Finder App lets you quickly and easily find the sill angle of existing double-hung windows. Available for free for both iPhone® and Android™ smartphones. Download app for iPhone from the App Store™ or for Android smartphones from the Google Play Store. The app is only available for smartphones, as tablets and other large devices are too bulky for measuring window sill angles.

For more information about **glass, patterned glass, grilles and TruScene insect screens**, see pages 12-14.

For more information about **combination designs, product performance, installation instructions and accessories**, see pages 181-211 or visit [andersenwindows.com](http://andersenwindows.com).

### Exterior Stop Cover



An exterior stop cover provides a clean transition from new window to the existing window casing.

### Included Installation Materials



Flat, self-hanging shims, backer rod, installation screws and complete instructions are included with each insert window. Measurement guide and worksheet at [andersenwindows.com/measure](http://andersenwindows.com/measure).

### Sash Options\*



Cottage

Reverse Cottage

## ACCESSORIES Sold Separately

### Frame

#### Wood Interior Stop



Optional interior stop with matching chamfer is available.

#### Sash

#### Window Opening Control Device Kit



A Window Opening Control Device Kit is available, which limits sash travel to less than 4" (102) when the window is first opened. Available factory applied or field applied in stone and white.

### Installation

#### Coil Stock



Andersen® aluminum coil stock can be ordered to match any of our 11 trim colors. Made from .018" thick aluminum, Andersen coil stock is available in 24" (610) x 50' (15240) rolls. Color-matched stainless steel trim nails 1 1/4" (32) long are also available and can be ordered in 1 lb/.454 kg boxes.

### Security Sensors

#### Open/Closed Sensors

Wireless open/closed sensors are available in four colors. See page 15 for details.

### Insect Screens

#### Insect Screen Frames



Choose full insect screen or half insect screen. Half insect screen (shown above) allows ventilation without affecting the view through the upper sash. Frames are available in colors to match product exteriors.

#### TruScene® Insect Screen

Exclusive Andersen TruScene insect screens provide over 50% more clarity than our conventional insect screens for a beautiful unobstructed view. They allow more fresh air and sunlight in, while doing a better job of keeping out small insects.

#### Conventional Insect Screen

Conventional insect screens have charcoal powder-coated aluminum screen mesh.

### Grilles

Grilles are available in a variety of configurations and widths. For double-hung grille patterns, see page 72.

#### CAUTION:

- Painting and staining may cause damage to rigid vinyl.
- Do not paint 400 Series windows with white, canvas, Sandtone, forest green, dark bronze or black exterior colors.
- Andersen does not warrant the adhesion or performance of homeowner-applied paint over vinyl or other factory-coated surfaces.
- 400 Series windows in Terratone color may be painted any color lighter than Terratone color using quality oil-based or latex paint.
- For vinyl painting instructions and preparation, contact your Andersen supplier.
- Do not paint weatherstrip.
- Creosote-based stains should not come in contact with Andersen products.
- Abrasive cleaners or solutions containing corrosive solvents should not be used on Andersen products.

\* Shown on 400 Series tilt-wash double-hung full-frame windows. Dimensions in parentheses are in millimeters.

"iPhone" and "App Store" are registered trademarks of Apple Inc. "Android" is a trademark of Google Inc.

# WOODWRIGHT® DOUBLE-HUNG INSERT WINDOWS

## Woodwright® Double-Hung, Picture & Transom Insert Window Sizes

### Double-Hung - Equal

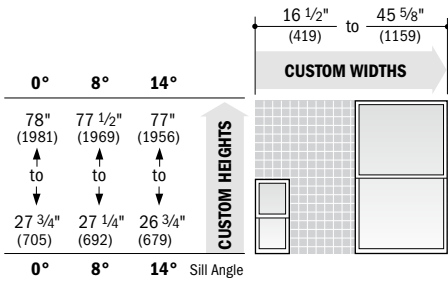

### Double-Hung - 2:3 Cottage & 3:2 Reverse Cottage

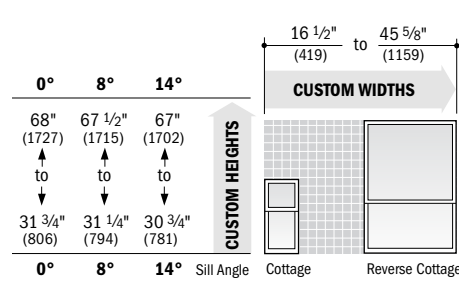

### Picture

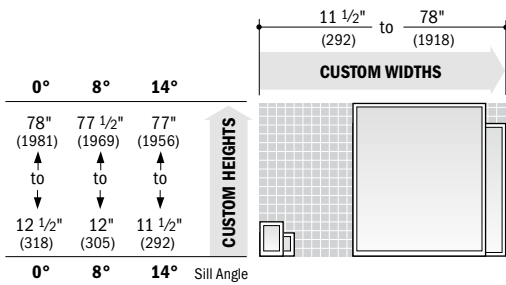

### Transom

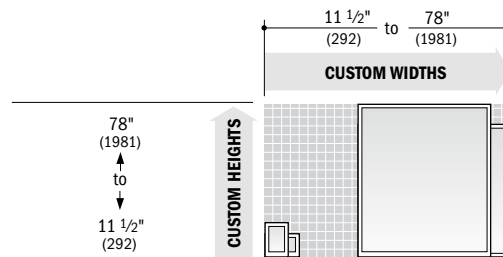

Available in 1/8" (3) increments between minimum and maximum widths and heights. Height limits for double-hung and picture insert windows depend on new insert window sill angle.

**For picture and transom insert windows, either height or width must be 68" (1727) or less and height plus width cannot be less than 28" (711).**

Measurement guide for custom sized windows can be found at [andersenwindows.com/measure](http://andersenwindows.com/measure). Grille patterns shown on page 72.

## Woodwright® Double-Hung Insert Window Specification Formulas

Clear Opening	Width = window width - 3.4375" (87)				
	Height = Depends on sash ratio and specific sill angle of insert window, see below.				
	sash ratio	clear opening height	sill angle deduction		
			14°	8°	0°
	1:1 Equal	= (window height ÷ 2) - sill angle deduction	3.1875" (81)	3.4375" (87)	3.75" (95)
	2:3 Cottage	= (window height x 2) ÷ 5 - sill angle deduction	2.875" (73)	3.0625" (78)	3.25" (83)
3:2 Reverse Cottage	= (window height x 2) ÷ 5 - sill angle deduction	2.375" (60)	2.5625" (65)	2.8125" (71)	
Vent Opening	Width = window width - 3.4375" (87)				
	Height = Depends on sash ratio and specific sill angle of insert window, see below.				
	sash ratio	vent opening height	sill angle deduction		
			14°	8°	0°
	Equal, Height < 48" (1219)	= ((window height ÷ 2) - sill angle deduction) - 6.5" (165)	2.75" (70)	2.9375" (75)	3.25" (83)
	Equal, Height > 48" (1219)	= ((window height ÷ 2) - sill angle deduction) - 11.5" (292)			
	Cottage, Height < 48" (1219)	= ((window height x 2) ÷ 5 - sill angle deduction) - 6.5" (165)	1.9375" (49)	2.125" (54)	2.375" (60)
	Cottage, Height > 48" (1219)	= ((window height x 2) ÷ 5 - sill angle deduction) - 11.5" (292)			
Reverse Cottage, Height < 48" (1219)	= ((window height x 2) ÷ 5 - sill angle deduction) - 6.5" (165)	3.5625" (90)	3.8125" (97)	4.8125" (122)	
Reverse Cottage, Height > 48" (1219)	= ((window height x 2) ÷ 5 - sill angle deduction) - 11.5" (292)				
Unobstr. Glass	Width = window width - 6.0" (152)				
	Height = Depends on sash ratio and specific sill angle of insert window, see below.				
	sash ratio	unobstructed glass height	sill angle deduction		
			14°	8°	0°
	Equal - Upper and Lower Sash	= window height - sill angle deduction	7.875" (200)	8.375" (213)	9.0" (229)
	Cottage - Upper Sash or Reverse Cottage - Lower Sash	= (window height x 2) ÷ 5 - sill angle deduction	3.1875" (81)	3.375" (86)	3.625" (92)
Cottage - Lower Sash or Reverse Cottage - Upper Sash	= (window height x 2) ÷ 5 - sill angle deduction	4.75" (121)	5.0625" (129)	5.4375" (138)	

## Woodwright® Picture and Transom Insert Window Specification Formulas

Unobstr. Glass	Picture Insert	Transom Insert			
		Width = window width - 6.0" (152)			
	Width = window width - 6.0" (152) Height = Depends on sash ratio and specific sill angle of insert window, see below.	Height = window width - 6.0" (152)			
		unobstructed glass height	sill angle deductions		
			14°	8°	0°
		= window height - sill angle deduction	5.816" (148)	6.285" (160)	6.890" (175)

• Dimensions in parentheses are in millimeters.  
 • **Clear Opening** formulas provide dimensions for determining area available for egress.  
**Vent Opening** formulas provide dimensions for determining area available for passage of air. **Unobstr. Glass** (unobstructed glass) formulas provide dimensions for determining area available for passage of light.  
 • Refer to [andersenwindows.com/measure](http://andersenwindows.com/measure) for detailed instructions on how to properly measure for insert windows.

## Existing Window Measurements

Required measurements:

1. Existing Opening Height
2. Existing Sill Angle
3. Existing Opening Width

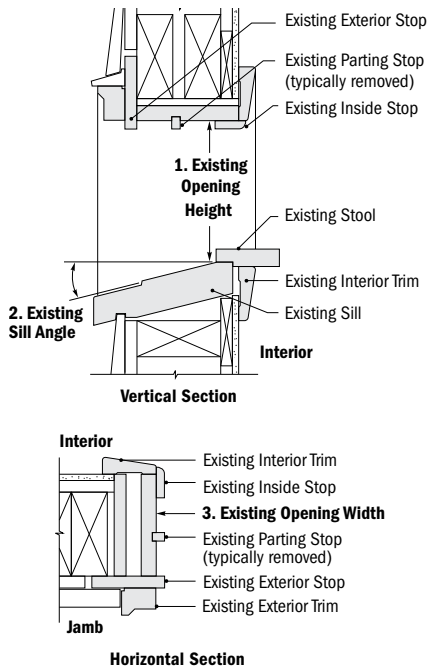

### Existing Double-Hung Window

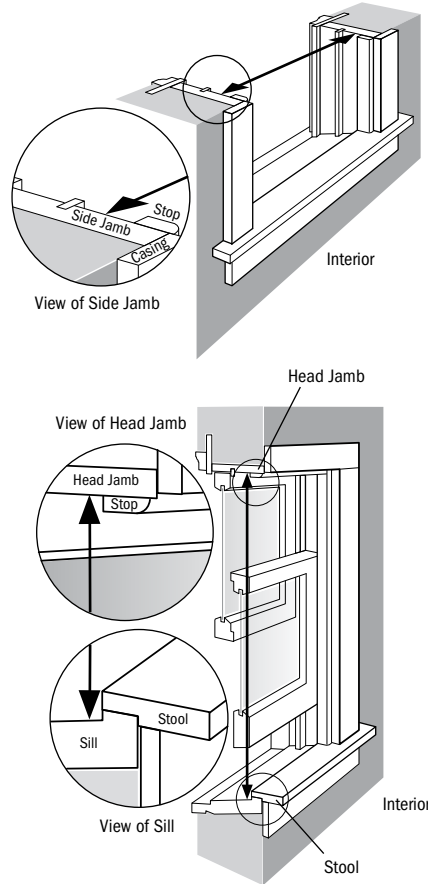

### Existing Picture Window

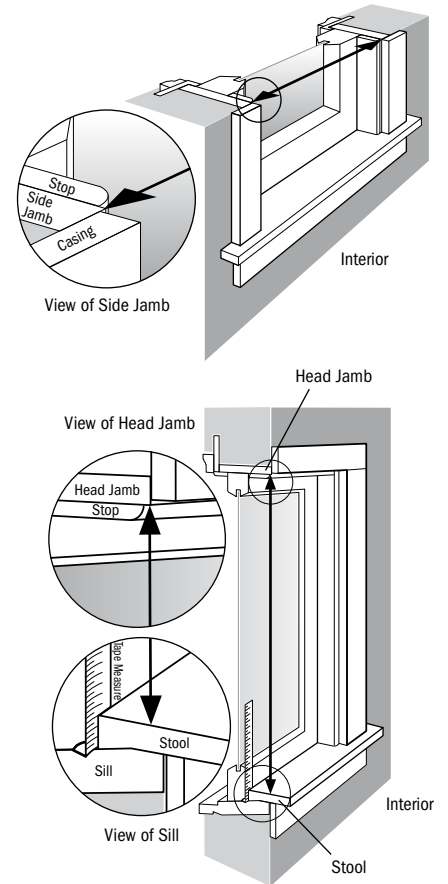

## Sill Angle Details

Scale 3" (76) = 1'-0" (305) – 1:4

Select a sill angle that most closely matches your existing sill angle.

Windows with a smaller sill angle will have a larger maximum height.

A "Sill Angle Finder App" is available, see page 69.

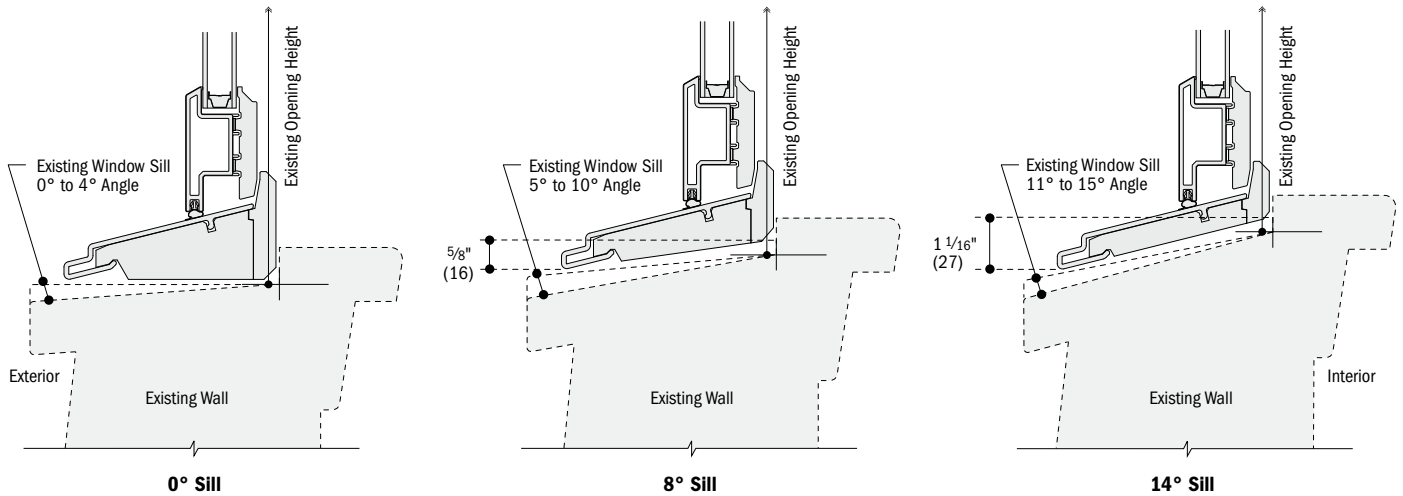

\*Details are for illustration only and are not intended to represent product installation methods or materials. Refer to product installation guides at andersenwindows.com.  
\*Dimensions in parentheses are in millimeters.  
\*Refer to andersenwindows.com/measure for detailed instructions on how to properly measure for insert windows.

# WOODWRIGHT® DOUBLE-HUNG INSERT WINDOWS

## Grille Patterns

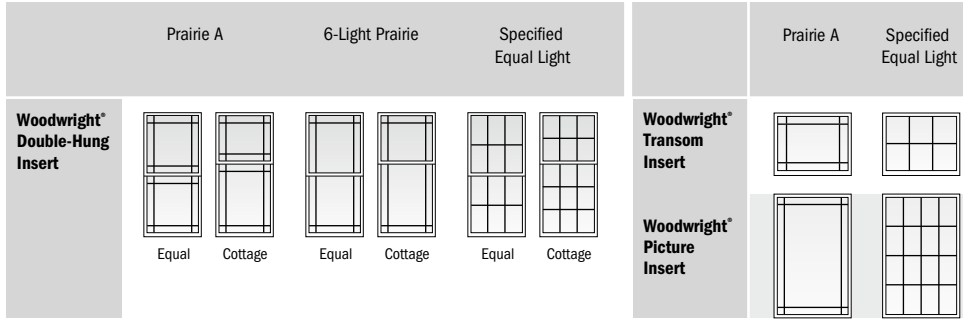

Patterns for double-hung windows are also available in Upper Sash Only (USO) configurations. For picture window patterns that require alignment with double-hung window patterns, identify the sash style (equal, cottage, reverse cottage) when ordering. **Number of lights and overall pattern varies with window size. Patterns are not available in all configurations.** For more grille options, see page 13 or visit [andersenwindows.com/grilles](http://andersenwindows.com/grilles).

## Woodwright® Double-Hung Insert Window Details

Scale 1 1/2" (38) = 1'-0" (305) – 1:8

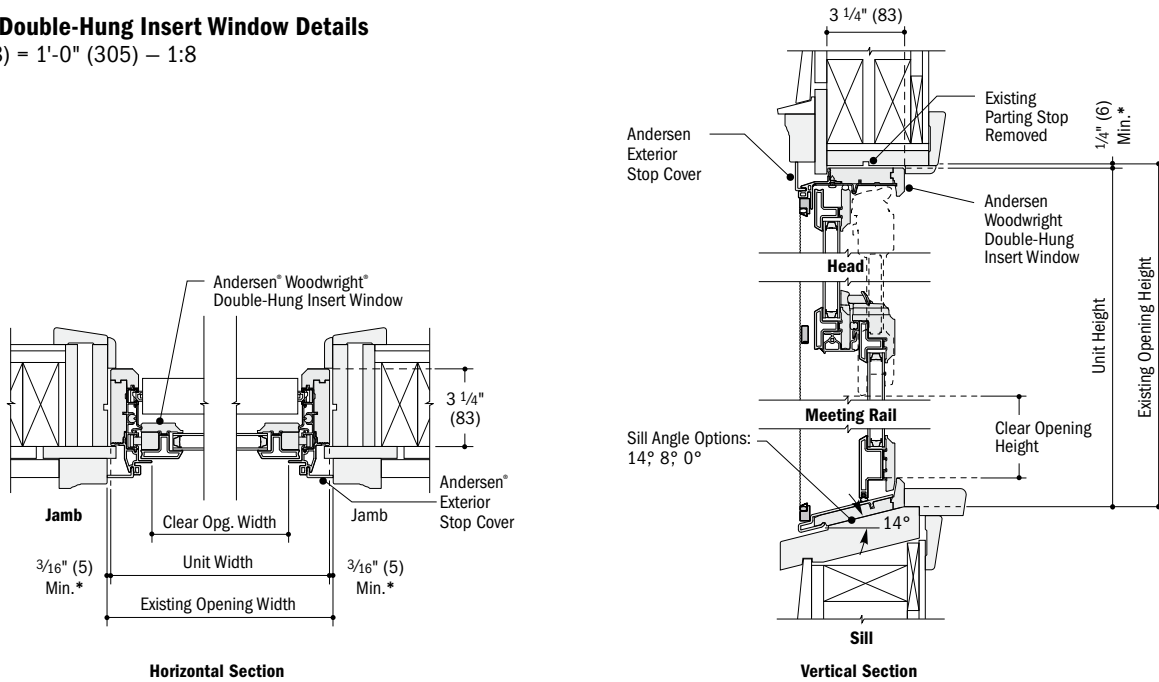

\* Light-colored areas are parts included with window. Dark-colored areas are additional Andersen® parts required to complete window assembly as shown.  
 \* Details are for illustration only and are not intended to represent product installation methods or materials. Refer to product installation guides at [andersenwindows.com](http://andersenwindows.com).  
 \* Dimensions in parentheses are in millimeters.  
 \* Refer to [andersenwindows.com/measure](http://andersenwindows.com/measure) for detailed instructions on how to properly measure for insert windows.

**Woodwright® Picture Insert Window Details**

Scale 1½" (38) = 1'-0" (305) – 1:8

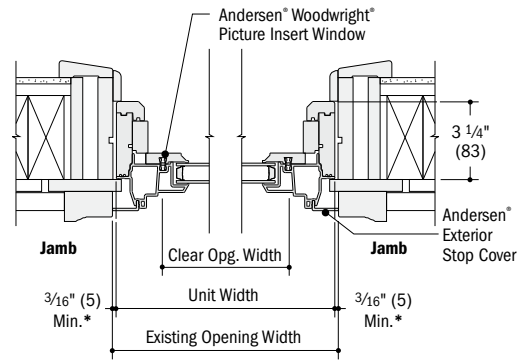

**Horizontal Section**

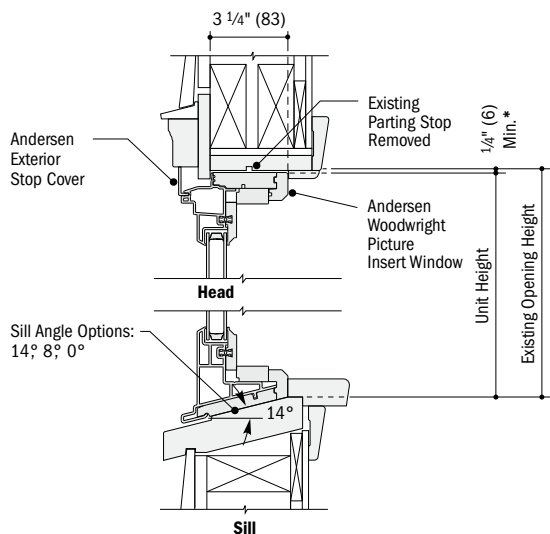

**Vertical Section**

**Woodwright® Transom Insert Window Details**

Scale 1½" (38) = 1'-0" (305) – 1:8

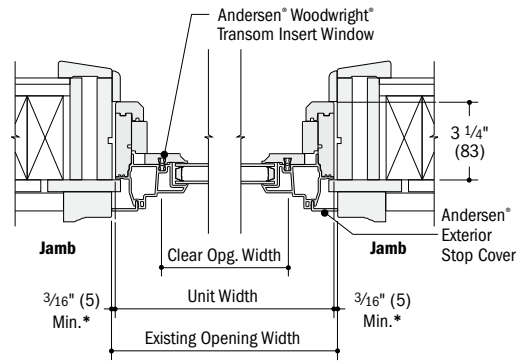

**Horizontal Section**

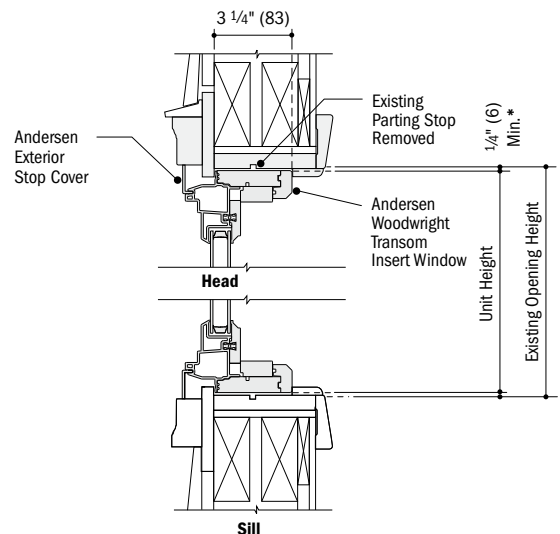

**Vertical Section**

**Joining Combinations**

Join insert windows in one-way horizontal (stack) or vertical (ribbon) combinations.

Do not join insert windows in two-way combinations.

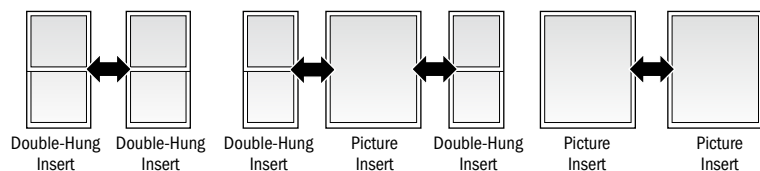
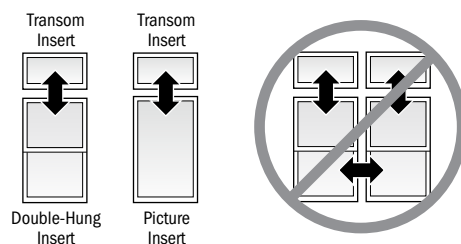

**Vertical (ribbon) Joining Detail**

Scale 1½" (38) = 1'-0" (305) – 1:8

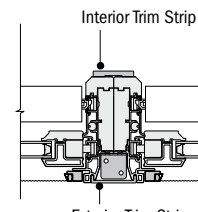

**Horizontal Section**

Woodwright® Double-Hung Insert to Woodwright Double-Hung Insert

**For more joining information, see the combination designs section starting on page 181.**

\* Light-colored areas are parts included with window. Dark-colored areas are additional Andersen® parts required to complete window assembly as shown.  
 \* Details are for illustration only and are not intended to represent product installation methods or materials. Refer to product installation guides at andersenwindows.com.  
 \* Dimensions in parentheses are in millimeters.  
 \* Refer to andersenwindows.com/measure for detailed instructions on how to properly measure for insert windows.

400 Series  
Woodwright® Double-Hung  
Insert Windows

# NOTES

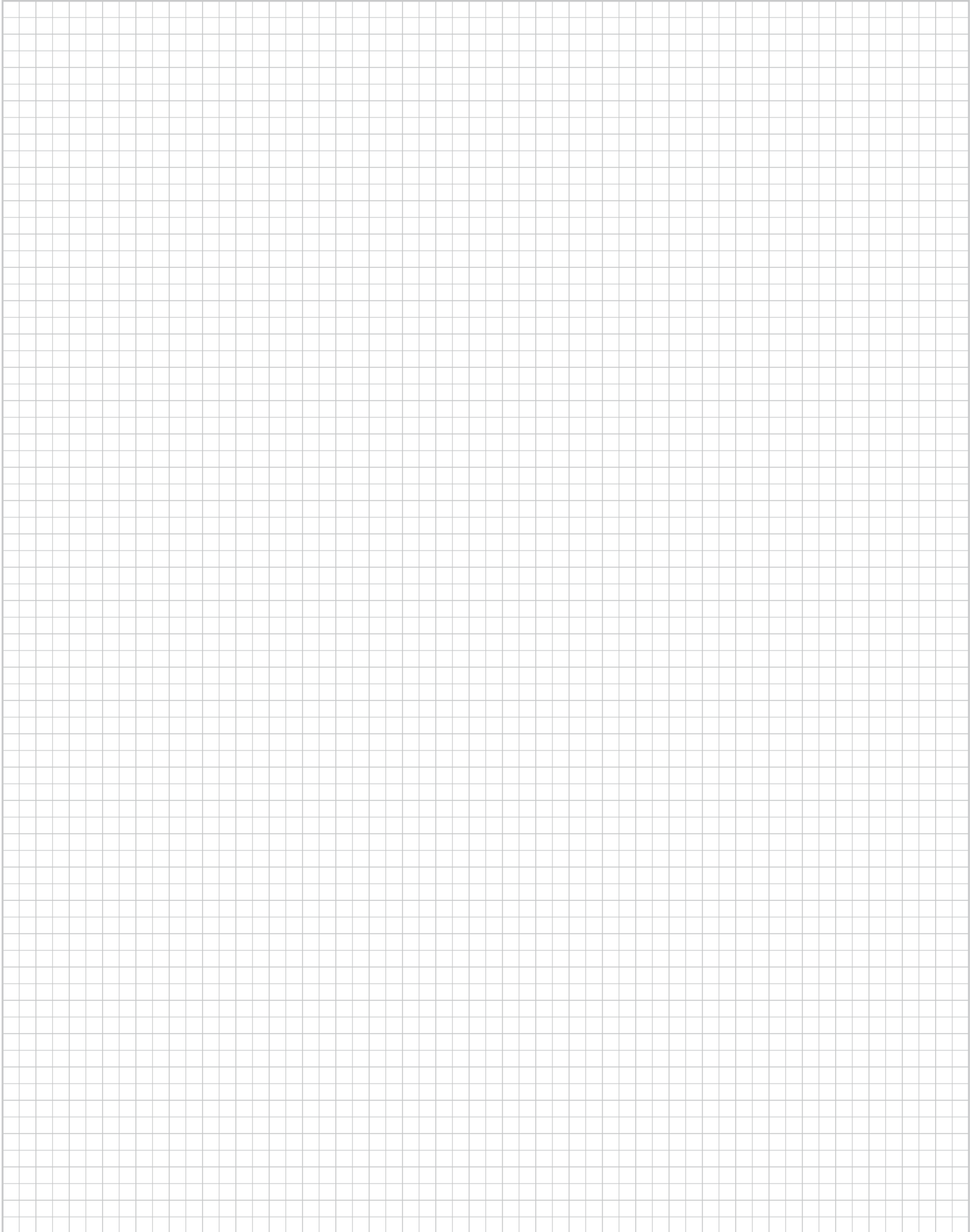

# TILT-WASH DOUBLE-HUNG FULL-FRAME WINDOWS

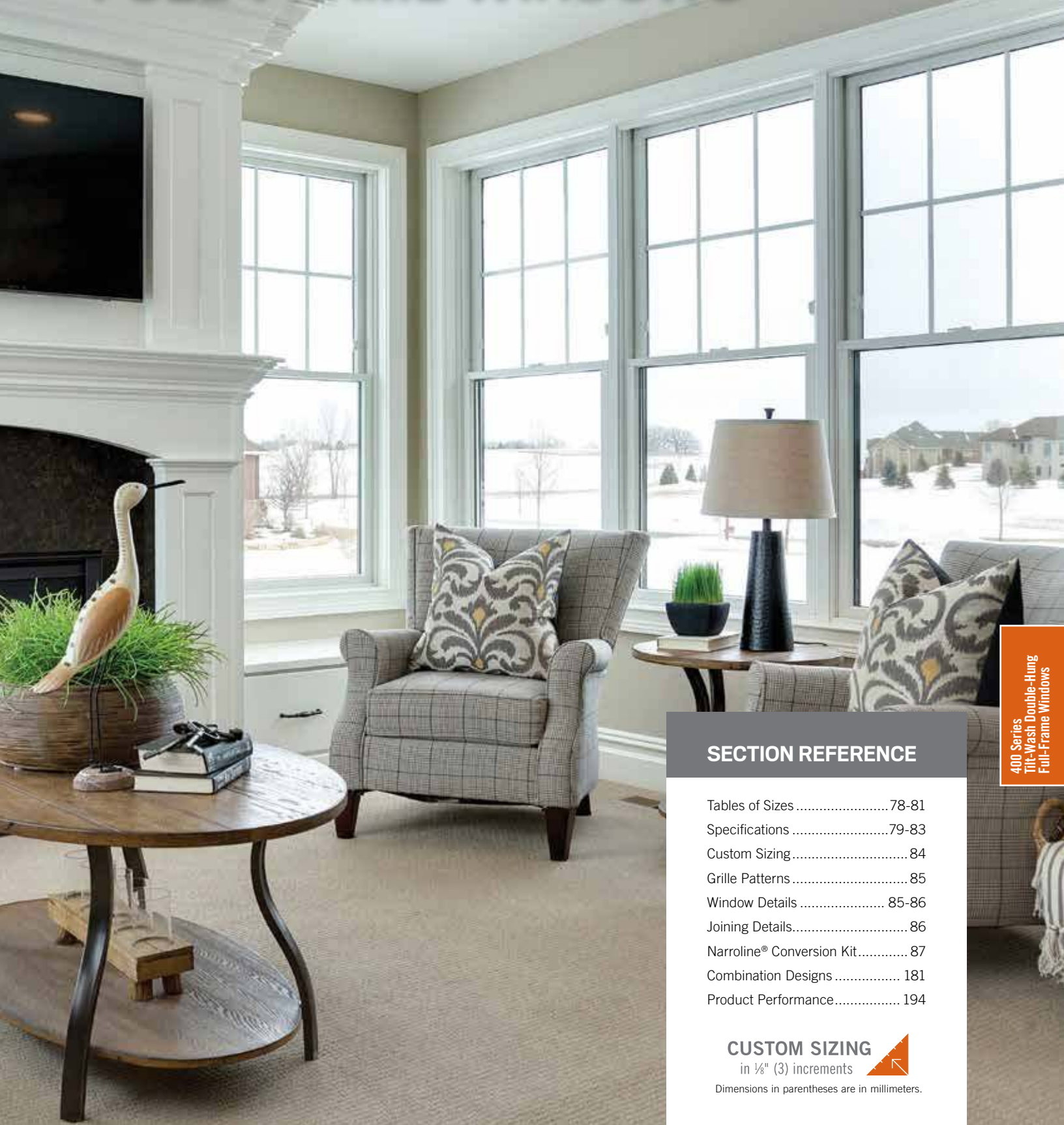

400 Series  
Tilt-Wash Double-Hung  
Full-Frame Windows

## SECTION REFERENCE

Tables of Sizes .....	78-81
Specifications .....	79-83
Custom Sizing .....	84
Grille Patterns .....	85
Window Details .....	85-86
Joining Details.....	86
Narroline® Conversion Kit.....	87
Combination Designs .....	181
Product Performance.....	194

**CUSTOM SIZING**  
in 1/8" (3) increments



Dimensions in parentheses are in millimeters.

# TILT-WASH DOUBLE-HUNG FULL-FRAME WINDOWS

## FEATURES

### Frame

- A** Exterior outer frame members are covered with a Perma-Shield® rigid vinyl cladding, minimizing maintenance and providing an attractive appearance.
- B** For exceptional long-lasting\* performance, sill members are constructed with a wood core and a Fibrex® material exterior. Sill ends are protected and sealed with weather-resistant covers.
- C** Natural wood stops are available in pine and prefinished white, dark bronze and black.\*\* A new, taller sill stop increases performance to PG40 while still maintaining egress on our most popular sizes.
- D** A factory-applied rigid vinyl anchoring flange on the head, sill and sides of the outer frame helps secure the unit to the structure.
- E** An extruded rigid vinyl jamb liner and fin provide a protective seal against the outer frame members. Exclusive slide wash assists make it easy to tilt sash into wash mode position.



Unique block-and-tackle balancers feature sized-to-the-unit, rust-resistant springs that require no adjustment. Glass-reinforced nylon balancer shoes provide smooth, reliable sash operation. Sash can be removed, without tools, for drywall pass-through. Jamb liners are available in white or gray and must be specified when ordering. Contact your Andersen supplier for details.

**F** Weatherstrip throughout the unit provides a long-lasting, energy-efficient, weather-resistant seal. For the top and bottom rails, an encased foam material is used. The head jamb liner and sill have a rigid vinyl rib that the weatherstrip material compresses against. At the meeting rail, compressible vinyl bulb material is used. Side jamb liners use leaf-type weatherstrip with foam inserts.

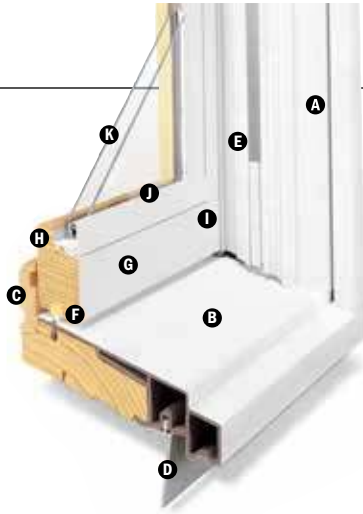

### Sash

- Wash assists make it easy to tilt the sash into wash mode.
- H** Wood sash members are treated with a water-repellent preservative for long-lasting\* protection and performance. Interior surfaces are unfinished pine. Low-maintenance prefinished white interiors are also available.
- G** A polyester-stabilized coat with a Flexacron® finish is electrostatically applied to penetrate all exterior surfaces for maximum protection and a lustrous finish.
- I** Sash joints simulate the look of traditional mortise-and-tenon construction inside and out.

### Glass

- J** Silicone bed glazing provides superior weathertightness and durability.
- K** High-Performance glass options include:
  - Low-E4® glass
  - Low-E4 HeatLock® glass
  - Low-E4 Sun glass
  - Low-E4 SmartSun™ glass
  - Low-E4 SmartSunHeatLock glass

Tempered glass and other glass options are available. Contact your Andersen supplier.

A removable translucent film helps shield the glass from damage during delivery and construction and simplifies finishing at the jobsite.

### Patterned Glass

Patterned glass options are available. See page 12 for more details.

## EXTERIOR



## INTERIOR

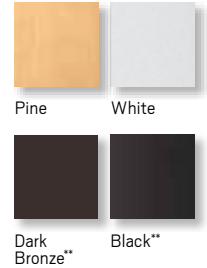

Naturally occurring variations in grain, color and texture of wood make each window one of a kind. All wood interiors are unfinished unless a prefinished option is specified.

## HARDWARE FINISHES



Distressed bronze and oil rubbed bronze are "living" finishes that will change with time and use.

## DOUBLE-HUNG HARDWARE

### STANDARD Lock & Keeper



Black | Gold Dust | **Stone** | White  
Stone is standard with natural interior units. White comes with prefinished white interiors. Other finishes optional.

## OPTIONAL DOUBLE-HUNG HARDWARE\*\*

### ESTATE™ Lock & Keeper



Optional Estate lock & keeper reduces the clear opening height by 3/16" (14). Check with local building code officials to determine compliance with egress requirements.

### CONTEMPORARY Bar Lift



Antique Brass | Black | Bright Brass  
Brushed Chrome | Distressed Bronze  
**Distressed Nickel** | Gold Dust  
Oil Rubbed Bronze | Polished Chrome  
Satin Nickel | Stone | White

### TRADITIONAL



Antique Brass | Black | Bright Brass | Brushed Chrome | Distressed Bronze | Distressed Nickel  
Gold Dust | **Oil Rubbed Bronze** | Polished Chrome | Satin Nickel | Stone | White

Bold name denotes finish shown.

\* Visit andersenwindows.com/warranty or for details.

\*\* Dark bronze and black interiors are only available with dark bronze and black exteriors respectively.

†Flexacron™ is a registered trademark of PPG Industries, Inc.

Dimensions in parentheses are in millimeters.

Printing limitations prevent exact replication of colors and finishes. See your Andersen supplier for actual color and finish samples.

**StormWATCH**  
PROTECTION

400 Series tilt-wash double-hung full-frame windows are available with Stormwatch® Protection. Visit [andersenwindows.com/coastal](http://andersenwindows.com/coastal) for more details.

**Performance Grade (PG) Upgrade**

A high inside sill stop\* with exterior sill brackets and hidden interior brackets are available to provide additional structural support for tilt-wash units, allowing standard glass units to achieve higher performance grade ratings. Performance Grade (PG) Ratings are more comprehensive than Design Pressure (DP) Ratings for measuring product performance. Use of this option will subtract 3/8" (15) from clear opening height. PG Upgrade not available for 72" (1829) and 76" (1930) heights. Contact your Andersen supplier for availability. For up-to-date performance information of individual products, please visit [andersenwindows.com](http://andersenwindows.com).

**Sash Options**



Cottage

Reverse Cottage

For more information about glass, patterned glass, art glass, grilles and TruScene insect screens, see pages 12-14.

For more information about combination designs, product performance, installation instructions and accessories, see pages 181-211 or visit [andersenwindows.com](http://andersenwindows.com).

**ACCESSORIES** Sold Separately

**Frame**

**Extension Jamb**



Standard jamb depth is 4 1/2" (114). Extension jambs are available in unfinished pine or prefinished white. Some sizes may be veneered.

Factory-applied and non-applied interior extension jambs are available in 1/16" (1.5) increments between 5 1/4" (129) and 7 1/8" (181). Extension jambs can be factory applied to either three sides (stool and apron application) or four sides (picture frame casing).

**Pine Stool**



A clear pine stool is available and ready for finishing. The tilt-wash stool is available in 4 9/16" (116) for use in wall depths up to 5 1/4" (133) and 6 3/16" (167) for use in wall depths up to 7 1/8" (181). Works with 2 1/4" (57) and 2 1/2" (64) wide casings.

**Hardware**

**Window Opening Control Device**



A recessed window opening control device is available factory applied. It limits the sash travel to less than 4" (102) when the window is first opened. Available in stone, white and black. A field-applied window opening control device is also available.

**Grilles**

Grilles are available in a variety of configurations and widths. For double-hung grille patterns, see page 84.

**Security Sensors**

**VeriLock® Sensors**

VeriLock sensors are available in five colors. See page 15 for details.

**Open/Closed Sensors**

Wireless open/closed sensors are available in four colors. See page 15 for details.

**Glass**

**Andersen® Art Glass**

Available for 400 Series tilt-wash transom and picture units. Andersen art glass panels come in a variety of original patterns. See pages 173-174 for details on Andersen art glass. Visit [andersenwindows.com/artglass](http://andersenwindows.com/artglass) for details and pattern information.

**Storm/Insect Screen Combination Unit\*\***



A self-storing storm window combined with an insect screen provides greater energy efficiency, while allowing ventilation when needed.

Constructed with an aluminum frame, single-pane upper and lower glass panels and charcoal powder-coated aluminum screen mesh. Available in white, Sandtone and Terratone to match product exteriors. Canvas, forest green, dark bronze and black available by special order.

Combination units can improve Sound Transmission Class (STC) and Outdoor Indoor Transmission Class (OITC) ratings. Ideal for projects near airports, busy roadways or other noisy environments.

For example, adding a combination unit to a 400 Series tilt-wash double-hung (3862) unit with Low-E4® glass will improve its STC rating from 26 to 32. Contact your Andersen supplier for additional STC and OITC rating information.

**Insect Screens**

**Insect Screen Frames**



Full and half insect screens are available for most unit sizes. Frame colors match product exteriors. Half insect screen (shown above) allows ventilation without affecting the view through the upper sash. Not available on windows with Stormwatch Protection.

**TruScene® Insect Screen**

Exclusive Andersen TruScene insect screens provide over 50% more clarity than our conventional insect screens for a beautiful unobstructed view. They allow more fresh air and sunlight in, while doing a better job of keeping out small insects.

**Conventional Insect Screen**

Conventional insect screens have charcoal powder-coated aluminum screen mesh.

**Exterior Trim**

This product is available with Andersen exterior trim. See pages 175-180 for details.

**CAUTION:**

- Painting and staining may cause damage to rigid vinyl.
- Do not paint 400 Series windows with white, canvas, Sandtone, forest green, dark bronze or black exterior colors.
- Andersen does not warrant the adhesion or performance of homeowner-applied paint over vinyl or other factory-coated surfaces.
- 400 Series windows in Terratone color may be painted any color lighter than Terratone color using quality oil-based or latex paint.
- For vinyl painting instructions and preparation, contact your Andersen supplier.
- Do not paint weatherstrip.
- Creosote-based stains should not come in contact with Andersen products.
- Abrasive cleaners or solutions containing corrosive solvents should not be used on Andersen products.

\* Infringes on the overall net clear opening. Unit clear operable area may not meet egress requirements. See your local building code official for more information.

\*\* Do not add combination units to windows with Low-E4 Sun glass, unless window glass is tempered. Combination units may also reduce the overall clear operable area of the window. See your local code official for egress requirements in your area.

† Values are based on comparison of Andersen double-hung window conversion kit U-Factor to the U-Factor for clear dual-pane glass non-metal frame default values from the 2006, 2009, 2012, 2015 and 2018 International Energy Conservation Code "Glazed Fenestration" Default Tables. Dimensions in parentheses are in millimeters.

# TILT-WASH DOUBLE-HUNG FULL-FRAME WINDOWS

**Table of Tilt-Wash Double-Hung Window Sizes**

Scale 1/8" (3) = 1'-0" (305) – 1:96

Window Dimension	1'-9 5/8"	2'-1 5/8"	2'-5 5/8"	2'-7 5/8"	2'-9 5/8"	2'-11 5/8"	3'-1 5/8"	3'-5 5/8"	3'-9 5/8"
	(549)	(651)	(752)	(803)	(854)	(905)	(956)	(1057)	(1159)
<b>Minimum Rough Opening</b>	1'-10 1/8"	2'-2 1/8"	2'-6 1/8"	2'-8 1/8"	2'-10 1/8"	3'-0 1/8"	3'-2 1/8"	3'-6 1/8"	3'-10 1/8"
	(562)	(664)	(765)	(816)	(867)	(917)	(968)	(1070)	(1172)
Unobstructed Glass (lower sash only)	15"	19"	23"	25"	27"	29"	31"	35"	39"
	(381)	(483)	(584)	(635)	(686)	(737)	(787)	(889)	(991)



**CUSTOM WIDTHS – 21 5/8" to 45 5/8"**

Window Dimension	CUSTOM WIDTHS – 21 5/8" to 45 5/8"									
	21 5/8"	23 1/8"	25 1/8"	27 1/8"	29 1/8"	31 1/8"	33 1/8"	35 1/8"	37 1/8"	39 1/8"
3'-0 7/8"	(937)	(937)	(937)	(937)	(937)	(937)	(937)	(937)	(937)	(937)
	TW18210	TW20210	TW24210	TW26210	TW28210	TW210210	TW30210	TW34210	TW38210	
3'-4 7/8"	(1038)	(1038)	(1038)	(1038)	(1038)	(1038)	(1038)	(1038)	(1038)	(1038)
	TW1832	TW2032	TW2432	TW2632	TW2832	TW21032	TW3032	TW3432	TW3832	
3'-8 7/8"	(1140)	(1140)	(1140)	(1140)	(1140)	(1140)	(1140)	(1140)	(1140)	(1140)
	TW1836	TW2036	TW2436	TW2636	TW2836	TW21036	TW3036	TW3436	TW3836	
4'-0 7/8"	(1241)	(1241)	(1241)	(1241)	(1241)	(1241)	(1241)	(1241)	(1241)	(1241)
	TW18310	TW20310	TW24310	TW26310	TW28310	TW210310	TW30310	TW34310	TW38310	
4'-4 7/8"	(1343)	(1343)	(1343)	(1343)	(1343)	(1343)	(1343)	(1343)	(1343)	(1343)
	TW1842	TW2042	TW2442	TW2642	TW2842	TW21042	TW3042	TW3442	TW3842	
4'-8 7/8"	(1445)	(1445)	(1445)	(1445)	(1445)	(1445)	(1445)	(1445)	(1445)	(1445)
	TW1846	TW2046	TW2446	TW2646	TW2846	TW21046	TW3046 <sup>o</sup>	TW3446 <sup>o</sup>	TW3846 <sup>o</sup>	
5'-0 7/8"	(1546)	(1546)	(1546)	(1546)	(1546)	(1546)	(1546)	(1546)	(1546)	(1546)
	TW18410	TW20410	TW24410	TW26410	TW28410	TW210410 <sup>o</sup>	TW30410 <sup>o</sup>	TW34410 <sup>o</sup>	TW38410 <sup>o</sup>	
5'-4 7/8"	(1648)	(1648)	(1648)	(1648)	(1648)	(1648)	(1648)	(1648)	(1648)	(1648)
	TW1852	TW2052	TW2452	TW2652	TW2852 <sup>o</sup>	TW21052 <sup>o</sup>	TW3052 <sup>o</sup>	TW3452 <sup>o</sup>	TW3852 <sup>o</sup>	
5'-8 7/8"	(1749)	(1749)	(1749)	(1749)	(1749)	(1749)	(1749)	(1749)	(1749)	(1749)
	TW1856	TW2056	TW2456	TW2656 <sup>o</sup>	TW2856 <sup>o</sup>	TW21056 <sup>o</sup>	TW3056 <sup>o</sup>	TW3456 <sup>o</sup>	TW3856 <sup>o</sup>	
6'-0 7/8"	(1851)	(1851)	(1851)	(1851)	(1851)	(1851)	(1851)	(1851)	(1851)	(1851)
	TW18510	TW20510	TW24510 <sup>o</sup>	TW26510 <sup>o</sup>	TW28510 <sup>o</sup>	TW210510 <sup>o</sup>	TW30510 <sup>o</sup>	TW34510 <sup>o</sup>	TW38510 <sup>o</sup>	
6'-4 7/8"	(1953)	(1953)	(1953)	(1953)	(1953)	(1953)	(1953)	(1953)	(1953)	(1953)
	TW1862	TW2062	TW2462 <sup>o</sup>	TW2662 <sup>o</sup>	TW2862 <sup>o</sup>	TW21062 <sup>o</sup>	TW3062 <sup>o</sup>	TW3462 <sup>o</sup>	TW3862 <sup>o</sup>	

**CUSTOM HEIGHTS – 36 7/8" to 92 7/8"**

Custom-size windows are available in 1/8" (3) increments. See page 84 for custom sizing.

Grille patterns shown on page 85.

Cottage or reverse cottage sash ratio available for heights shown below in all widths.

**CUSTOM WIDTHS – 21 5/8" to 45 5/8"**

**CUSTOM HEIGHTS – 48 1/8" to 76 7/8"**

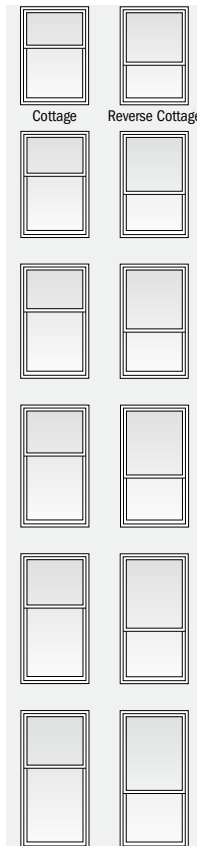

Size tables for windows with cottage or reverse cottage sash are available at [andersenwindows.com/sizing](http://andersenwindows.com/sizing).

- "Window Dimension" always refers to outside frame to frame dimension.
- "Minimum Rough Opening" dimensions may need to be increased to allow for use of building wraps, flashing, sill panning, brackets, fasteners or other items. See pages 210-211 for more details.
- Dimensions in parentheses are in millimeters.
- ◊ Meet or exceed clear opening area of 5.7 sq.ft. or 0.53 m<sup>2</sup>, clear opening width of 20" (508) and clear opening height of 24" (610). See tables on pages 82-83.

continued on next page

**Table of Tilt-Wash Double-Hung Window Sizes** (continued)

Scale 1/8" (3) = 1'-0" (305) – 1:96

Window Dimension	1'-9 5/8" (549)	2'-1 5/8" (651)	2'-5 5/8" (752)	2'-7 5/8" (803)	2'-9 5/8" (854)	2'-11 5/8" (905)	3'-1 5/8" (956)	3'-5 5/8" (1057)	3'-9 5/8" (1159)
<b>Minimum Rough Opening</b>	1'-10 1/8" (562)	2'-2 1/8" (664)	2'-6 1/8" (765)	2'-8 1/8" (816)	2'-10 1/8" (867)	3'-0 1/8" (917)	3'-2 1/8" (968)	3'-6 1/8" (1070)	3'-10 1/8" (1172)
Unobstructed Glass (lower sash only)	15" (381)	19" (483)	23" (584)	25" (635)	27" (686)	29" (737)	31" (787)	35" (889)	39" (991)

**CUSTOM WIDTHS – 21 5/8" to 45 5/8"**

**CUSTOM HEIGHTS – 36 7/8" to 92 7/8"**

TW1872	TW2072 <sup>◊</sup>	TW2472 <sup>◊</sup>	TW2672 <sup>◊</sup>	TW2872 <sup>◊</sup>	TW21072 <sup>◊</sup>	TW3072 <sup>◊</sup>	TW3472 <sup>◊</sup>	TW3872 <sup>◊</sup>
TW1876	TW2076 <sup>◊</sup>	TW2476 <sup>◊</sup>	TW2676 <sup>◊</sup>	TW2876 <sup>◊</sup>	TW21076 <sup>◊</sup>	TW3076 <sup>◊</sup>	TW3476 <sup>◊</sup>	TW3876 <sup>◊</sup>

- \*"Window Dimension" always refers to outside frame to frame dimension.
- \*"Minimum Rough Opening" dimensions may need to be increased to allow for use of building wraps, flashing, sill panning, brackets, fasteners or other items. See pages 210-211 for more details.
- ◊ Dimensions in parentheses are in millimeters.
- ◊ Meet or exceed clear opening area of 5.7 sq.ft. or 0.53 m<sup>2</sup>, clear opening width of 20" (508) and clear opening height of 24" (610). See tables on pages 82-83.



Custom-size windows are available in 1/8" (3) increments. See page 84 for custom sizing.

**Windows 7'-4 7/8" (2257) and 7'-8 7/8" (2359) high have interior and exterior brackets. Interior brackets, located on both sides of the meeting rail, must be flipped up for proper product performance. Andersen® reinforced joining materials must be used when vertically joining 7'-4 7/8" (2257) and 7'-8 7/8" (2359) height windows.**

Grille patterns shown on page 85.

**Tilt-Wash Transom Window Area Specifications**

Window Number	Glass Area Sq. Ft./ (m <sup>2</sup> )	Overall Window Area Sq. Ft./ (m <sup>2</sup> )
TWT1810	0.56 (0.05)	1.80 (0.17)
TWT1815	1.32 (0.12)	2.90 (0.27)
TWT1817	1.52 (0.14)	3.20 (0.30)
TWT18111	1.94 (0.18)	3.80 (0.35)
TWT1821	2.15 (0.20)	4.10 (0.38)
TWT1823	2.35 (0.22)	4.40 (0.41)
TWT1827	2.77 (0.26)	5.00 (0.47)
TWT1831	3.39 (0.32)	5.90 (0.55)
TWT2010	0.70 (0.07)	2.14 (0.20)
TWT2015	1.67 (0.16)	3.44 (0.32)
TWT2017	1.93 (0.18)	3.79 (0.35)
TWT20111	2.46 (0.23)	4.50 (0.42)
TWT2021	2.72 (0.25)	4.86 (0.45)
TWT2023	2.98 (0.28)	5.22 (0.49)
TWT2027	3.51 (0.33)	5.93 (0.55)
TWT2031	4.30 (0.40)	7.00 (0.65)
TWT2410	0.85 (0.08)	2.47 (0.23)
TWT2415	2.02 (0.19)	3.97 (0.37)
TWT2417	2.34 (0.22)	4.38 (0.41)
TWT24111	2.98 (0.28)	5.21 (0.48)
TWT2421	3.29 (0.31)	5.62 (0.52)
TWT2423	3.61 (0.34)	6.03 (0.56)
TWT2427	4.25 (0.40)	6.85 (0.64)
TWT2431	5.21 (0.48)	8.09 (0.75)
TWT2610	0.93 (0.09)	2.64 (0.25)
TWT2615	2.19 (0.20)	4.24 (0.39)
TWT2617	2.54 (0.24)	4.68 (0.44)

Window Number	Glass Area Sq. Ft./ (m <sup>2</sup> )	Overall Window Area Sq. Ft./ (m <sup>2</sup> )
TWT26111	3.23 (0.30)	5.56 (0.52)
TWT2621	3.58 (0.33)	6.00 (0.56)
TWT2623	3.93 (0.37)	6.44 (0.60)
TWT2627	4.62 (0.43)	7.32 (0.68)
TWT2631	5.66 (0.53)	8.63 (0.80)
TWT2810	1.00 (0.09)	2.80 (0.26)
TWT2815	2.37 (0.22)	4.51 (0.42)
TWT2817	2.74 (0.26)	4.98 (0.46)
TWT28111	3.49 (0.32)	5.91 (0.55)
TWT2821	3.87 (0.36)	6.38 (0.59)
TWT2823	4.24 (0.39)	6.84 (0.64)
TWT2827	4.99 (0.46)	7.78 (0.72)
TWT2831	6.12 (0.57)	9.18 (0.85)
TWT21010	1.07 (0.10)	2.97 (0.28)
TWT21015	2.55 (0.24)	4.78 (0.44)
TWT21017	2.95 (0.27)	5.27 (0.49)
TWT210111	3.75 (0.35)	6.26 (0.58)
TWT21021	4.15 (0.39)	6.76 (0.63)
TWT21023	4.56 (0.42)	7.25 (0.67)
TWT21027	5.36 (0.50)	8.24 (0.77)
TWT21031	6.57 (0.61)	9.73 (0.90)
TWT3010	1.15 (0.11)	3.14 (0.29)
TWT3015	2.72 (0.25)	5.05 (0.47)
TWT3017	3.15 (0.29)	5.57 (0.52)
TWT30111	4.01 (0.37)	6.61 (0.61)
TWT3021	4.44 (0.41)	7.14 (0.66)
TWT3023	4.87 (0.45)	7.66 (0.71)

Window Number	Glass Area Sq. Ft./ (m <sup>2</sup> )	Overall Window Area Sq. Ft./ (m <sup>2</sup> )
TWT3027	5.73 (0.53)	8.70 (0.81)
TWT3031	7.02 (0.65)	10.27 (0.95)
TWT3410	1.30 (0.12)	3.47 (0.32)
TWT3415	3.07 (0.29)	5.58 (0.52)
TWT3417	3.56 (0.33)	6.16 (0.57)
TWT34111	4.53 (0.42)	7.32 (0.68)
TWT3421	5.02 (0.47)	7.89 (0.73)
TWT3423	5.50 (0.51)	8.47 (0.79)
TWT3427	6.47 (0.60)	9.63 (0.90)
TWT3431	7.93 (0.74)	11.36 (1.06)
TWT3810	1.45 (0.14)	3.80 (0.35)
TWT3815	3.42 (0.32)	6.12 (0.57)
TWT3817	3.97 (0.37)	6.75 (0.63)
TWT38111	5.05 (0.47)	8.02 (0.75)
TWT3821	5.59 (0.52)	8.65 (0.80)
TWT3823	6.13 (0.57)	9.29 (0.86)
TWT3827	7.21 (0.67)	10.55 (0.98)
TWT3831	8.84 (0.82)	12.46 (1.16)
TWT31010	1.51 (0.14)	3.94 (0.37)
TWT4210	1.66 (0.15)	4.28 (0.40)
TWT41010	1.95 (0.18)	4.94 (0.46)
TWT5610	2.25 (0.21)	5.61 (0.52)
TWT6210	2.55 (0.24)	6.28 (0.58)

\* Dimensions in parentheses are in square meters.

400 Series  
Tilt-Wash Double-Hung  
Full-Frame Windows

# TILT-WASH DOUBLE-HUNG FULL-FRAME WINDOWS

**Table of Tilt-Wash Transom Window Sizes**

Scale 1/8" = 1'-0" (1:96)

Window Dimension	1'-9 5/8"	2'-1 5/8"	2'-5 5/8"	2'-7 5/8"	2'-9 5/8"	2'-11 5/8"	3'-1 5/8"	3'-5 5/8"	3'-9 5/8"	3'-11 5/16"	4'-3 5/16"
	(549)	(651)	(752)	(803)	(854)	(905)	(956)	(1057)	(1159)	(1202)	(1303)
<b>Minimum Rough Opening</b>	1'-10 1/8"	2'-2 1/8"	2'-6 1/8"	2'-8 1/8"	2'-10 1/8"	3'-0 1/8"	3'-2 1/8"	3'-6 1/8"	3'-10 1/8"	3'-11 7/8"	4'-3 7/8"
	(562)	(664)	(765)	(816)	(867)	(917)	(968)	(1070)	(1172)	(1215)	(1318)
Unobstructed Glass	15"	19"	23"	25"	27"	29"	31"	35"	39"	40 11/16"	44 11/16"
	(380)	(482)	(583)	(635)	(685)	(737)	(787)	(888)	(990)	(1033)	(1135)

**CUSTOM WIDTHS – 21 5/8" to 75 5/16"**

Window Dimension	CUSTOM HEIGHTS – 12" to 39 5/16"										
	1'-0"	1'-7 5/16"	1'-9 5/16"	2'-1 5/16"	2'-3 5/16"	2'-5 5/16"	2'-9 5/16"	3'-3 5/16"	3'-5 5/16"	3'-9 5/16"	3'-11 5/16"
1'-0"	(305)	(491)	(541)	(643)	(694)	(745)	(846)	(999)			
1'-7 5/16"	(318)	(504)	(555)	(657)	(707)	(758)	(860)	(1012)			
1'-9 5/16"	(316)	(504)	(555)	(657)	(707)	(758)	(860)	(1012)			
2'-1 5/16"	(372)	(558)	(609)	(711)	(761)	(812)	(914)	(1066)			
2'-3 5/16"	(474)	(660)	(711)	(813)	(863)	(914)	(1016)	(1168)			
2'-5 5/16"	(576)	(762)	(813)	(915)	(965)	(1016)	(1118)	(1270)			
2'-9 5/16"	(678)	(864)	(915)	(1017)	(1067)	(1118)	(1220)	(1372)			
3'-3 5/16"	(829)	(1015)	(1066)	(1168)	(1218)	(1269)	(1371)	(1523)			
3'-5 5/16"	(831)	(1017)	(1068)	(1170)	(1220)	(1271)	(1373)	(1525)			
3'-9 5/16"	(933)	(1119)	(1170)	(1272)	(1322)	(1373)	(1475)	(1627)			
3'-11 5/16"	(935)	(1121)	(1172)	(1274)	(1324)	(1375)	(1477)	(1629)			



Custom-size windows are available in 1/8" (3) increments. See page 84 for custom sizing.

Grille patterns shown on page 85.

\* "Window Dimension" always refers to outside frame to frame dimension.  
 \* "Minimum Rough Opening" dimensions may need to be increased to allow for use of building wraps, flashing, sill panning, brackets, fasteners or other items. See pages 210-211 for more details.  
 \* Dimensions in parentheses are in millimeters.

## Tilt-Wash Picture Window Area Specifications

Window Number	Glass Area Sq. Ft./ (m <sup>2</sup> )	Overall Window Area Sq. Ft./ (m <sup>2</sup> )
DHP10310	2.03 (0.19)	4.07 (0.38)
DHP1042	2.22 (0.21)	4.41 (0.41)
DHP1046	2.42 (0.23)	4.74 (0.44)
DHP10410	2.61 (0.24)	5.07 (0.47)
DHP1052	2.81 (0.26)	5.41 (0.50)
DHP1056	3.01 (0.28)	5.74 (0.53)
DHP10510	3.20 (0.30)	6.07 (0.56)
DHP1062	3.40 (0.32)	6.41 (0.60)
DHP30310	9.38 (0.87)	12.77 (1.19)
DHP3042	10.29 (0.96)	13.82 (1.28)
DHP3046	11.19 (1.04)	14.86 (1.38)
DHP30410	12.10 (1.12)	15.91 (1.48)
DHP3052	13.01 (1.21)	16.95 (1.58)
DHP3056	13.92 (1.29)	18.00 (1.67)
DHP30510	14.83 (1.38)	19.04 (1.77)
DHP3062	15.73 (1.46)	20.09 (1.87)
DHP34310	10.53 (0.98)	14.13 (1.31)
DHP3442	11.54 (1.07)	15.28 (1.42)
DHP3446	12.56 (1.17)	16.44 (1.53)

Window Number	Glass Area Sq. Ft./ (m <sup>2</sup> )	Overall Window Area Sq. Ft./ (m <sup>2</sup> )
DHP34410	13.58 (1.26)	17.60 (1.64)
DHP3452	14.60 (1.36)	18.75 (1.74)
DHP3456	15.62 (1.45)	19.91 (1.85)
DHP34510	16.64 (1.55)	21.07 (1.96)
DHP3462	17.66 (1.64)	22.22 (2.06)
DHP310310	12.16 (1.13)	16.06 (1.49)
DHP31042	13.33 (1.24)	17.37 (1.61)
DHP31046	14.51 (1.35)	18.69 (1.74)
DHP310410	15.69 (1.46)	20.00 (1.86)
DHP31052	16.87 (1.57)	21.32 (1.98)
DHP31056	18.04 (1.68)	22.63 (2.10)
DHP310510	19.22 (1.79)	23.94 (2.22)
DHP31062	20.40 (1.90)	25.26 (2.35)
DHP42310	13.30 (1.24)	17.42 (1.62)
DHP4242	14.56 (1.35)	18.83 (1.75)
DHP4246	15.88 (1.48)	20.27 (1.88)
DHP42410	17.17 (1.60)	21.69 (2.02)
DHP4252	18.46 (1.72)	23.12 (2.15)
DHP4256	19.75 (1.84)	24.54 (2.28)

Window Number	Glass Area Sq. Ft./ (m <sup>2</sup> )	Overall Window Area Sq. Ft./ (m <sup>2</sup> )
DHP42510	21.03 (1.95)	25.97 (2.41)
DHP4262	22.32 (2.07)	27.39 (2.55)
DHP410310	15.60 (1.45)	20.13 (1.87)
DHP41042	17.11 (1.59)	21.78 (2.02)
DHP41046	18.62 (1.73)	23.43 (2.18)
DHP410410	20.13 (1.87)	25.07 (2.33)
DHP41052	21.64 (2.01)	26.72 (2.48)
DHP41056	23.15 (2.15)	28.37 (2.64)
DHP410510	24.66 (2.29)	30.02 (2.79)
DHP41062	26.17 (2.43)	31.66 (2.94)
DHP56310	17.89 (1.66)	22.85 (2.12)
DHP5642	19.63 (1.82)	24.72 (2.30)
DHP5646	21.36 (1.98)	26.59 (2.47)
DHP56410	23.09 (2.15)	28.46 (2.64)
DHP5652	24.83 (2.31)	30.33 (2.82)
DHP5656	26.56 (2.47)	32.20 (2.99)
DHP56510	28.29 (2.63)	34.07 (3.17)
DHP5662	30.02 (2.79)	35.93 (3.34)

\* Dimensions in parentheses are in square meters.

4'-11 5/16" (1057)	5'-7 5/16" (1710)	6'-3 5/16" (1913)
4'-11 7/8" (1070)	5'-7 7/8" (1724)	6'-3 7/8" (1927)
52 11/16" (905)	60 11/16" (1556)	68 11/16" (1745)

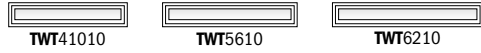

**Table of Tilt-Wash Picture Window Sizes**

Scale 1/8" (3) = 1'-0" (305) – 1:96

Window Dimension	1'-0"	3'-1 5/8"	3'-5 5/8"	3'-11 5/16"	4'-3 5/16"	4'-11 5/16"	5'-7 5/16"
	(305)	(956)	(1057)	(1202)	(1303)	(1507)	(1710)
<b>Minimum Rough Opening</b>	1'-0 1/2" (318)	3'-2 1/8" (968)	3'-6 1/8" (1070)	3'-11 7/8" (1216)	4'-3 7/8" (1318)	4'-11 7/8" (1521)	5'-7 7/8" (1724)
Unobstructed Glass	7 1/16" (179)	32 11/16" (830)	36 11/16" (932)	42 3/8" (1076)	46 3/8" (1178)	54 3/8" (1381)	62 3/8" (1584)

CUSTOM WIDTHS – 12" to 67 5/16"		CUSTOM HEIGHTS – 48 7/8" to 76 7/8"							
4'-0 7/8" (1241)	4'-0 7/8" (1241)	41 5/16" (1049)	DHP10310	DHP30310	DHP34310	DHP310310	DHP42310	DHP410310	DHP56310
4'-4 7/8" (1343)	4'-4 7/8" (1343)	45 5/16" (1151)	DHP1042	DHP3042	DHP3442	DHP31042	DHP4242	DHP41042	DHP5642
4'-8 7/8" (1445)	4'-8 7/8" (1445)	49 5/16" (1253)	DHP1046	DHP3046	DHP3446	DHP31046	DHP4246	DHP41046	DHP5646
5'-0 7/8" (1547)	5'-0 7/8" (1547)	53 5/16" (1355)	DHP10410	DHP30410	DHP34410	DHP310410	DHP42410	DHP410410	DHP56410
5'-4 7/8" (1648)	5'-4 7/8" (1648)	57 5/16" (1456)	DHP1052	DHP3052	DHP3452	DHP31052	DHP4252	DHP41052	DHP5652
5'-8 7/8" (1749)	5'-8 7/8" (1749)	61 5/16" (1557)	DHP1056	DHP3056	DHP3456	DHP31056	DHP4256	DHP41056	DHP5656
6'-0 7/8" (1851)	6'-0 7/8" (1851)	65 5/16" (1659)	DHP10510	DHP30510	DHP34510	DHP310510	DHP42510	DHP410510	DHP56510
6'-4 7/8" (1953)	6'-4 7/8" (1953)	69 5/16" (1761)	DHP1062	DHP3062	DHP3462	DHP31062	DHP4262	DHP41062	DHP5662



Custom-size windows are available in 1/8" (3) increments. See page 84 for custom sizing.

Grille patterns shown on page 85.

• "Window Dimension" always refers to outside frame to frame dimension.  
 • "Minimum Rough Opening" dimensions may need to be increased to allow for use of building wraps, flashing, sill panning, brackets, fasteners or other items. See pages 210-211 for more details.  
 • Dimensions in parentheses are in millimeters.

400 Series  
Tilt-Wash Double-Hung  
Full-Frame Windows

# TILT-WASH DOUBLE-HUNG FULL-FRAME WINDOWS

## Tilt-Wash Double-Hung Window Opening and Area Specifications

Window Number	Clear Opening Area Sq. Ft./ (m <sup>2</sup> )	Clear Opening in Full Open Position		Glass Area Sq. Ft./ (m <sup>2</sup> )	Vent Area Sq. Ft./ (m <sup>2</sup> )	Top of Subfloor to Top of Inside Sill Stop Inches/(mm)	Overall Window Area Sq. Ft./ (m <sup>2</sup> )
		Width Inches/(mm)	Height Inches/(mm)				
TW18210	1.77 (0.16)	17 7/8" (454)	14 1/4" (362)	2.90 (0.27)	1.78 (0.17)	48 1/2" (1231)	5.53 (0.51)
TW1832	2.02 (0.19)	17 7/8" (454)	16 1/4" (412)	3.32 (0.31)	2.03 (0.19)	44 1/2" (1130)	6.14 (0.57)
TW1836	2.26 (0.21)	17 7/8" (454)	18 1/4" (463)	3.74 (0.35)	2.28 (0.21)	40 1/2" (1028)	6.74 (0.63)
TW18310	2.51 (0.23)	17 7/8" (454)	20 1/4" (514)	4.15 (0.39)	2.53 (0.24)	36 1/2" (926)	7.34 (0.68)
TW1842	2.76 (0.26)	17 7/8" (454)	22 1/4" (565)	4.57 (0.43)	2.78 (0.26)	32 1/2" (825)	7.94 (0.74)
TW1846	3.07 (0.29)	17 7/8" (454)	24 3/4" (628)	4.98 (0.46)	3.03 (0.28)	28 1/2" (711)	8.54 (0.79)
TW18410	3.26 (0.30)	17 7/8" (454)	26 1/4" (666)	5.40 (0.50)	3.27 (0.30)	24 1/2" (622)	9.14 (0.85)
TW1852	3.51 (0.33)	17 7/8" (454)	28 1/4" (717)	5.81 (0.54)	3.52 (0.33)	20 1/2" (520)	9.74 (0.91)
TW1856	3.75 (0.35)	17 7/8" (454)	30 1/4" (768)	6.23 (0.58)	3.77 (0.35)	16 1/2" (418)	10.34 (0.96)
TW18510	4.00 (0.37)	17 7/8" (454)	32 1/4" (819)	6.65 (0.62)	4.02 (0.37)	12 1/2" (317)	10.94 (1.02)
TW1862	4.12 (0.38)	17 7/8" (454)	33 1/4" (843)	7.06 (0.66)	4.24 (0.39)	8 1/2" (203)	11.54 (1.07)
TW1872	5.00 (0.46)	17 7/8" (454)	40 1/4" (1022)	8.32 (0.77)	5.03 (0.47)	10 1/4" (260)*	13.35 (1.24)
TW1876	5.24 (0.49)	17 7/8" (454)	42 1/4" (1073)	8.74 (0.81)	5.27 (0.49)	6 1/4" (159)*	13.95 (1.30)
TW20210	2.16 (0.20)	21 7/8" (556)	14 1/4" (362)	3.68 (0.34)	2.18 (0.20)	48 1/2" (1231)	6.56 (0.61)
TW2032	2.47 (0.23)	21 7/8" (556)	16 1/4" (412)	4.21 (0.39)	2.48 (0.23)	44 1/2" (1130)	7.27 (0.68)
TW2036	2.77 (0.26)	21 7/8" (556)	18 1/4" (463)	4.73 (0.44)	2.79 (0.26)	40 1/2" (1028)	7.98 (0.74)
TW20310	3.07 (0.29)	21 7/8" (556)	20 1/4" (514)	5.26 (0.49)	3.09 (0.29)	36 1/2" (926)	8.69 (0.81)
TW2042	3.38 (0.31)	21 7/8" (556)	22 1/4" (565)	5.79 (0.54)	3.40 (0.32)	32 1/2" (825)	9.41 (0.87)
TW2046	3.76 (0.35)	21 7/8" (556)	24 3/4" (628)	6.31 (0.59)	3.71 (0.34)	28 1/2" (711)	10.12 (0.94)
TW20410	3.99 (0.37)	21 7/8" (556)	26 1/4" (666)	6.84 (0.64)	4.00 (0.37)	24 1/2" (622)	10.83 (1.01)
TW2052	4.29 (0.40)	21 7/8" (556)	28 1/4" (717)	7.37 (0.69)	4.31 (0.40)	20 1/2" (520)	11.54 (1.07)
TW2056	4.59 (0.43)	21 7/8" (556)	30 1/4" (768)	7.89 (0.73)	4.61 (0.43)	16 1/2" (418)	12.25 (1.14)
TW20510	4.90 (0.46)	21 7/8" (556)	32 1/4" (819)	8.42 (0.78)	4.92 (0.46)	12 1/2" (317)	12.96 (1.20)
TW2062	5.04 (0.47)	21 7/8" (556)	33 1/4" (843)	8.95 (0.83)	5.18 (0.48)	8 1/2" (203)	13.68 (1.27)
TW2072 ◊	6.11 (0.57)	21 7/8" (556)	40 1/4" (1022)	10.54 (0.98)	6.14 (0.57)	10 1/4" (260)*	15.82 (1.47)
TW2076 ◊	6.42 (0.60)	21 7/8" (556)	42 1/4" (1073)	11.06 (1.03)	6.45 (0.60)	6 1/4" (159)*	16.53 (1.54)
TW24210	2.56 (0.24)	25 7/8" (657)	14 1/4" (362)	4.46 (0.41)	2.58 (0.24)	48 1/2" (1231)	7.58 (0.70)
TW2432	2.92 (0.27)	25 7/8" (657)	16 1/4" (412)	5.09 (0.47)	2.94 (0.27)	44 1/2" (1130)	8.40 (0.78)
TW2436	3.28 (0.31)	25 7/8" (657)	18 1/4" (463)	5.73 (0.53)	3.30 (0.31)	40 1/2" (1028)	9.23 (0.86)
TW24310	3.64 (0.34)	25 7/8" (657)	20 1/4" (514)	6.37 (0.59)	3.66 (0.34)	36 1/2" (926)	10.05 (0.93)
TW2442	4.00 (0.37)	25 7/8" (657)	22 1/4" (565)	7.01 (0.65)	4.02 (0.37)	32 1/2" (825)	10.87 (1.01)
TW2446	4.44 (0.41)	25 7/8" (657)	24 3/4" (628)	7.65 (0.71)	4.39 (0.41)	28 1/2" (711)	11.70 (1.09)
TW24410	4.71 (0.44)	25 7/8" (657)	26 1/4" (666)	8.28 (0.77)	4.74 (0.44)	24 1/2" (622)	12.52 (1.16)
TW2452	5.07 (0.47)	25 7/8" (657)	28 1/4" (717)	8.92 (0.83)	5.10 (0.47)	20 1/2" (520)	13.34 (1.24)
TW2456	5.43 (0.51)	25 7/8" (657)	30 1/4" (768)	9.56 (0.89)	5.46 (0.51)	16 1/2" (418)	14.17 (1.32)
TW24510 ◊	5.79 (0.54)	25 7/8" (657)	32 1/4" (819)	10.20 (0.95)	5.81 (0.54)	12 1/2" (317)	14.99 (1.39)
TW2462 ◊	5.97 (0.55)	25 7/8" (657)	33 1/4" (843)	10.84 (1.01)	6.13 (0.57)	8 1/2" (203)	15.81 (1.47)
TW2472 ◊	7.23 (0.67)	25 7/8" (657)	40 1/4" (1022)	12.76 (1.19)	7.26 (0.68)	10 1/4" (260)*	18.28 (1.70)
TW2476 ◊	7.59 (0.71)	25 7/8" (657)	42 1/4" (1073)	13.40 (1.25)	7.62 (0.71)	6 1/4" (159)*	19.11 (1.78)
TW26210	2.76 (0.26)	27 7/8" (708)	14 1/4" (362)	4.84 (0.45)	2.78 (0.26)	48 1/2" (1231)	8.09 (0.75)
TW2632	3.14 (0.29)	27 7/8" (708)	16 1/4" (412)	5.54 (0.52)	3.17 (0.30)	44 1/2" (1130)	8.97 (0.83)
TW2636	3.53 (0.33)	27 7/8" (708)	18 1/4" (463)	6.23 (0.58)	3.55 (0.33)	40 1/2" (1028)	9.85 (0.92)
TW26310	3.92 (0.36)	27 7/8" (708)	20 1/4" (514)	6.92 (0.64)	3.94 (0.37)	36 1/2" (926)	10.73 (1.00)
TW2642	4.30 (0.40)	27 7/8" (708)	22 1/4" (565)	7.62 (0.71)	4.33 (0.40)	32 1/2" (825)	11.61 (1.08)
TW2646	4.79 (0.44)	27 7/8" (708)	24 3/4" (628)	8.31 (0.77)	4.73 (0.44)	28 1/2" (711)	12.49 (1.16)
TW26410	5.08 (0.47)	27 7/8" (708)	26 1/4" (666)	9.01 (0.84)	5.10 (0.47)	24 1/2" (622)	13.36 (1.24)
TW2652	5.47 (0.51)	27 7/8" (708)	28 1/4" (717)	9.70 (0.90)	5.49 (0.51)	20 1/2" (520)	14.24 (1.32)
TW2656 ◊	5.85 (0.54)	27 7/8" (708)	30 1/4" (768)	10.39 (0.96)	5.88 (0.55)	16 1/2" (418)	15.12 (1.41)
TW26510 ◊	6.24 (0.58)	27 7/8" (708)	32 1/4" (819)	11.09 (1.03)	6.26 (0.58)	12 1/2" (317)	16.00 (1.49)
TW2662 ◊	6.43 (0.60)	27 7/8" (708)	33 1/4" (843)	11.78 (1.09)	6.61 (0.61)	8 1/2" (203)	16.88 (1.57)
TW2672 ◊	7.79 (0.72)	27 7/8" (708)	40 1/4" (1022)	13.86 (1.29)	7.82 (0.73)	10 1/4" (260)*	19.52 (1.81)
TW2676 ◊	8.18 (0.76)	27 7/8" (708)	42 1/4" (1073)	14.56 (1.35)	8.21 (0.76)	6 1/4" (159)*	20.40 (1.89)
TW28210	2.95 (0.27)	29 7/8" (759)	14 1/4" (362)	5.23 (0.49)	2.98 (0.28)	48 1/2" (1231)	8.61 (0.80)
TW2832	3.37 (0.31)	29 7/8" (759)	16 1/4" (412)	5.98 (0.56)	3.39 (0.32)	44 1/2" (1130)	9.54 (0.89)
TW2836	3.78 (0.35)	29 7/8" (759)	18 1/4" (463)	6.73 (0.63)	3.81 (0.35)	40 1/2" (1028)	10.47 (0.97)
TW28310	4.20 (0.39)	29 7/8" (759)	20 1/4" (514)	7.48 (0.70)	4.22 (0.39)	36 1/2" (926)	11.41 (1.06)
TW2842	4.61 (0.43)	29 7/8" (759)	22 1/4" (565)	8.23 (0.77)	4.64 (0.43)	32 1/2" (825)	12.34 (1.15)
TW2846	5.13 (0.48)	29 7/8" (759)	24 3/4" (628)	8.98 (0.83)	5.07 (0.47)	28 1/2" (711)	13.28 (1.23)
TW28410	5.44 (0.51)	29 7/8" (759)	26 1/4" (666)	9.73 (0.90)	5.47 (0.51)	24 1/2" (622)	14.21 (1.32)
TW2852 ◊	5.86 (0.54)	29 7/8" (759)	28 1/4" (717)	10.48 (0.97)	5.88 (0.55)	20 1/2" (520)	15.14 (1.41)

**Opening calculations change when using PG Upgrade sill stop.** For opening specifications for windows with Stormwatch® Protection, visit [andersenwindows.com/openingspecs](http://andersenwindows.com/openingspecs).

For cottage and reverse cottage sash opening specifications, visit [andersenwindows.com/openingspecs](http://andersenwindows.com/openingspecs).

\*Top of Subfloor to Top of Inside Sill Stop" is calculated based upon a structural header height of 6'-10 1/2" (2096) except for 7'-5" and 7'-9" heights which are calculated using a header height of 8" (2438).

\*Dimensions in parentheses are in millimeters or square meters.

◊ Meet or exceed clear opening area of 5.7 sq. ft. or 0.53 m<sup>2</sup>, clear opening width of 20" (508) and clear opening height of 24" (610).

\*Calculated based upon a structural header height of 8" (2438).

continued on next page

**Tilt-Wash Double-Hung Window Opening and Area Specifications** *(continued)*

Window Number	Clear Opening Area Sq. Ft./ (m <sup>2</sup> )	Clear Opening in Full Open Position		Glass Area Sq. Ft./ (m <sup>2</sup> )	Vent Area Sq. Ft./ (m <sup>2</sup> )	Top of Subfloor to Top of Inside Sill Stop Inches/ (mm)	Overall Window Area Sq. Ft./ (m <sup>2</sup> )
		Width Inches/ (mm)	Height Inches/ (mm)				
TW2856 ◊	6.27 (0.58)	29 7/8" (759)	30 1/4" (768)	11.22 (1.04)	6.30 (0.59)	16 1/2" (418)	16.08 (1.49)
TW28510 ◊	6.69 (0.62)	29 7/8" (759)	32 1/4" (819)	11.97 (1.11)	6.71 (0.62)	12 1/2" (317)	17.01 (1.58)
TW2862 ◊	6.89 (0.64)	29 7/8" (759)	33 1/4" (843)	12.72 (1.18)	7.08 (0.66)	8 1/2" (203)	17.95 (1.67)
TW2872 ◊	8.35 (0.78)	29 7/8" (759)	40 1/4" (1022)	14.98 (1.39)	8.38 (0.78)	10 1/4" (260)*	20.75 (1.93)
TW2876 ◊	8.77 (0.81)	29 7/8" (759)	42 1/4" (1073)	15.72 (1.46)	8.80 (0.82)	6 1/4" (159)*	21.69 (2.01)
TW210210	3.15 (0.29)	31 7/8" (809)	14 1/4" (362)	5.62 (0.52)	3.18 (0.30)	48 1/2" (1231)	9.12 (0.85)
TW21032	3.59 (0.33)	31 7/8" (809)	16 1/4" (412)	6.42 (0.60)	3.62 (0.34)	44 1/2" (1130)	10.11 (0.94)
TW21036	4.04 (0.38)	31 7/8" (809)	18 1/4" (463)	7.23 (0.67)	4.06 (0.38)	40 1/2" (1028)	11.10 (1.03)
TW210310	4.48 (0.42)	31 7/8" (809)	20 1/4" (514)	8.03 (0.75)	4.51 (0.42)	36 1/2" (926)	12.09 (1.12)
TW21042	4.92 (0.46)	31 7/8" (809)	22 1/4" (565)	8.84 (0.82)	4.95 (0.46)	32 1/2" (825)	13.08 (1.22)
TW21046	5.48 (0.51)	31 7/8" (809)	24 3/4" (628)	9.64 (0.90)	5.41 (0.50)	28 1/2" (711)	14.07 (1.31)
TW210410 ◊	5.81 (0.54)	31 7/8" (809)	26 1/4" (666)	10.45 (0.97)	5.83 (0.54)	24 1/2" (622)	15.05 (1.40)
TW21052 ◊	6.25 (0.58)	31 7/8" (809)	28 1/4" (717)	11.25 (1.05)	6.28 (0.58)	20 1/2" (520)	16.04 (1.49)
TW21056 ◊	6.69 (0.62)	31 7/8" (809)	30 1/4" (768)	12.06 (1.12)	6.72 (0.62)	16 1/2" (418)	17.03 (1.59)
TW210510 ◊	7.14 (0.66)	31 7/8" (809)	32 1/4" (819)	12.86 (1.20)	7.16 (0.67)	12 1/2" (317)	18.02 (1.67)
TW21062 ◊	7.35 (0.68)	31 7/8" (809)	33 1/4" (843)	13.67 (1.27)	7.55 (0.70)	8 1/2" (203)	19.01 (1.77)
TW21072 ◊	8.91 (0.83)	31 7/8" (810)	40 1/4" (1022)	16.08 (1.49)	8.94 (0.83)	10 1/4" (260)*	21.99 (2.04)
TW21076 ◊	9.35 (0.87)	31 7/8" (810)	42 1/4" (1073)	16.90 (1.57)	9.38 (0.87)	6 1/4" (159)*	22.98 (2.13)
TW30210	3.35 (0.31)	33 7/8" (860)	14 1/4" (362)	6.01 (0.56)	3.38 (0.31)	48 1/2" (1231)	9.63 (0.90)
TW3032	3.82 (0.36)	33 7/8" (860)	16 1/4" (412)	6.87 (0.64)	3.85 (0.36)	44 1/2" (1130)	10.67 (0.99)
TW3036	4.29 (0.40)	33 7/8" (860)	18 1/4" (463)	7.73 (0.72)	4.32 (0.40)	40 1/2" (1028)	11.72 (1.09)
TW30310	4.76 (0.44)	33 7/8" (860)	20 1/4" (514)	8.59 (0.80)	4.79 (0.45)	36 1/2" (926)	12.76 (1.19)
TW3042	5.23 (0.49)	33 7/8" (860)	22 1/4" (565)	9.45 (0.88)	5.26 (0.49)	32 1/2" (825)	13.81 (1.28)
TW3046 ◊	5.82 (0.54)	33 7/8" (860)	24 3/4" (628)	10.31 (0.96)	5.75 (0.53)	28 1/2" (711)	14.85 (1.38)
TW30410 ◊	6.17 (0.57)	33 7/8" (860)	26 1/4" (666)	11.17 (1.04)	6.20 (0.58)	24 1/2" (622)	15.90 (1.48)
TW3052 ◊	6.64 (0.62)	33 7/8" (860)	28 1/4" (717)	12.03 (1.12)	6.67 (0.62)	20 1/2" (520)	16.95 (1.58)
TW3056 ◊	7.11 (0.66)	33 7/8" (860)	30 1/4" (768)	12.89 (1.20)	7.14 (0.66)	16 1/2" (418)	17.99 (1.67)
TW30510 ◊	7.58 (0.70)	33 7/8" (860)	32 1/4" (819)	13.75 (1.28)	7.61 (0.71)	12 1/2" (317)	19.04 (1.77)
TW3062 ◊	7.81 (0.73)	33 7/8" (860)	33 1/4" (843)	14.61 (1.36)	8.03 (0.75)	8 1/2" (203)	20.08 (1.87)
TW3072 ◊	9.47 (0.88)	33 7/8" (860)	40 1/4" (1022)	17.20 (1.60)	9.50 (0.88)	10 1/4" (260)*	23.22 (2.16)
TW3076 ◊	9.94 (0.92)	33 7/8" (860)	42 1/4" (1073)	18.06 (1.68)	9.97 (0.93)	6 1/4" (159)*	24.27 (2.25)
TW34210	3.74 (0.35)	37 7/8" (962)	14 1/4" (362)	6.79 (0.63)	3.78 (0.35)	48 1/2" (1231)	10.65 (0.99)
TW3432	4.27 (0.40)	37 7/8" (962)	16 1/4" (412)	7.76 (0.72)	4.30 (0.40)	44 1/2" (1130)	11.81 (1.10)
TW3436	4.80 (0.45)	37 7/8" (962)	18 1/4" (463)	8.73 (0.81)	4.83 (0.45)	40 1/2" (1028)	12.97 (1.21)
TW34310	5.32 (0.49)	37 7/8" (962)	20 1/4" (514)	9.70 (0.90)	5.35 (0.50)	36 1/2" (926)	14.12 (1.31)
TW3442	5.85 (0.54)	37 7/8" (962)	22 1/4" (565)	10.67 (0.99)	5.88 (0.55)	32 1/2" (825)	15.28 (1.42)
TW3446 ◊	6.51 (0.60)	37 7/8" (962)	24 3/4" (628)	11.64 (1.08)	6.42 (0.60)	28 1/2" (711)	16.43 (1.53)
TW34410 ◊	6.90 (0.64)	37 7/8" (962)	26 1/4" (666)	12.61 (1.17)	6.93 (0.64)	24 1/2" (622)	17.59 (1.63)
TW3452 ◊	7.43 (0.69)	37 7/8" (962)	28 1/4" (717)	13.58 (1.26)	7.46 (0.69)	20 1/2" (520)	18.75 (1.74)
TW3456 ◊	7.95 (0.74)	37 7/8" (962)	30 1/4" (768)	14.55 (1.35)	7.98 (0.74)	16 1/2" (418)	19.90 (1.85)
TW34510 ◊	8.48 (0.79)	37 7/8" (962)	32 1/4" (819)	15.53 (1.44)	8.51 (0.79)	12 1/2" (317)	21.06 (1.96)
TW3462 ◊	8.73 (0.81)	37 7/8" (962)	33 1/4" (843)	16.50 (1.53)	8.98 (0.83)	8 1/2" (203)	22.22 (2.06)
TW3472 ◊	10.59 (0.98)	37 7/8" (962)	40 1/4" (1022)	19.42 (1.80)	10.62 (0.99)	10 1/4" (260)*	25.69 (2.39)
TW3476 ◊	11.11 (1.03)	37 7/8" (962)	42 1/4" (1073)	20.38 (1.89)	11.14 (1.04)	6 1/4" (159)*	26.85 (2.49)
TW38210	4.14 (0.39)	41 7/8" (1064)	14 1/4" (362)	7.56 (0.70)	4.17 (0.39)	48 1/2" (1231)	11.68 (1.09)
TW3832	4.72 (0.44)	41 7/8" (1064)	16 1/4" (412)	8.64 (0.80)	4.76 (0.44)	44 1/2" (1130)	12.94 (1.20)
TW3836	5.30 (0.49)	41 7/8" (1064)	18 1/4" (463)	9.72 (0.90)	5.34 (0.50)	40 1/2" (1028)	14.21 (1.32)
TW38310	5.88 (0.55)	41 7/8" (1064)	20 1/4" (514)	10.81 (1.00)	5.92 (0.55)	36 1/2" (926)	15.48 (1.44)
TW3842	6.47 (0.60)	41 7/8" (1064)	22 1/4" (565)	11.89 (1.11)	6.50 (0.60)	32 1/2" (825)	16.75 (1.56)
TW3846 ◊	7.19 (0.67)	41 7/8" (1064)	24 3/4" (628)	12.97 (1.21)	7.10 (0.66)	28 1/2" (711)	18.01 (1.67)
TW38410 ◊	7.63 (0.71)	41 7/8" (1064)	26 1/4" (666)	14.05 (1.31)	7.66 (0.71)	24 1/2" (622)	19.28 (1.79)
TW3852 ◊	8.21 (0.76)	41 7/8" (1064)	28 1/4" (717)	15.14 (1.41)	8.25 (0.77)	20 1/2" (520)	20.55 (1.91)
TW3856 ◊	8.79 (0.82)	41 7/8" (1064)	30 1/4" (768)	16.22 (1.51)	8.83 (0.82)	16 1/2" (418)	21.62 (2.01)
TW38510 ◊	9.37 (0.87)	41 7/8" (1064)	32 1/4" (819)	17.30 (1.61)	9.41 (0.87)	12 1/2" (317)	23.08 (2.14)
TW3862 ◊	9.66 (0.90)	41 7/8" (1064)	33 1/4" (843)	18.38 (1.71)	9.92 (0.92)	8 1/2" (203)	24.35 (2.26)
TW3872 ◊	11.70 (1.09)	41 7/8" (1064)	40 1/4" (1022)	21.64 (2.01)	11.73 (1.09)	10 1/4" (260)*	28.16 (2.26)
TW3876 ◊	12.29 (1.14)	41 7/8" (1064)	42 1/4" (1073)	22.72 (2.11)	12.32 (1.14)	6 1/4" (159)*	29.43 (2.73)

\*Top of Subfloor to Top of Inside Sill Stop" is calculated based upon a structural header height of 6'-10 1/2" (2096) except for 7'-5" and 7'-9" heights which are calculated using a header height of 8' (2438).

• Dimensions in parentheses are in millimeters or square meters.

◊ Meet or exceed clear opening area of 5.7 sq. ft. or 0.53 m<sup>2</sup>; clear opening width of 20" (508) and clear opening height of 24" (610).

\*Calculated based upon a structural header height of 8' (2438).

**Opening calculations change when using PG Upgrade sill stop.** For opening specifications for windows with Stormwatch® Protection, visit [andersenwindows.com/openingspecs](http://andersenwindows.com/openingspecs).

For cottage and reverse cottage sash opening specifications, visit [andersenwindows.com/openingspecs](http://andersenwindows.com/openingspecs).

# TILT-WASH DOUBLE-HUNG FULL-FRAME WINDOWS

## Custom Sizes and Specification Formulas



Available in 1/8" (3) increments between minimum and maximum widths and heights. Some restrictions apply, contact your Andersen supplier. For minimum rough opening dimensions for joined windows, see specific joining instruction guides. Measurement guide for custom-size windows can be found at [andersenwindows.com/measure](http://andersenwindows.com/measure).

### Tilt-Wash Double-Hung Windows

#### Equal

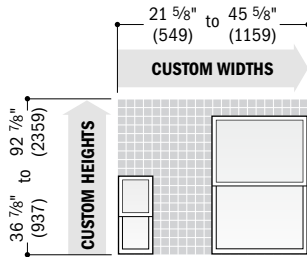

#### Cottage

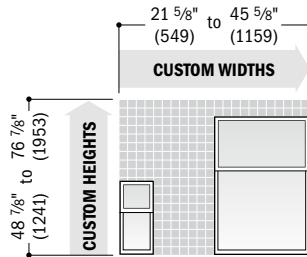

#### Reverse Cottage

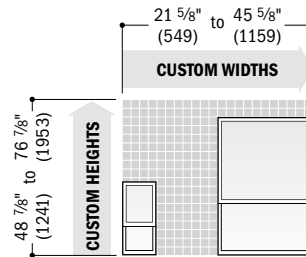

<b>Clear Opening</b> 	<b>Width</b> = window width - 1.852" (47) x 2 <i>Contact your Andersen supplier for clear opening height.</i>	<b>Minimum R.O.</b> 	<b>Width</b> = window width + 1/2" (51) <b>Height</b> = window height + 0"
<b>Vent Opening</b> 	<i>Vent opening formulas are dependent on window size, contact your Andersen supplier.</i>	<b>Unobstr. Glass</b> 	<b>Width</b> = window width - 3.376" (86) <b>Height:</b> <b>Upper Sash</b> = upper sash height - 3.035" (77) <b>Lower Sash</b> = lower sash height - 3.831" (97)

### Tilt-Wash Picture Windows

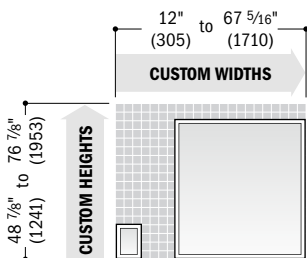

### Tilt-Wash Transom Windows

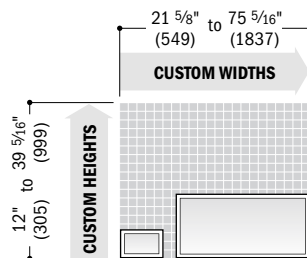

<b>Minimum R.O.</b> 	<b>Width</b> = window width + 1/2" (51) <b>Height</b> = window height + 0"	<b>Unobstr. Glass</b> 	<b>Picture Window</b> <b>Width</b> = window width - 4.924" (125) <b>Height</b> = window height - 7.531" (191)	<b>Transom Window</b> <b>Width</b> = window width - 6.625" (168) <b>Height</b> = window height - 6.625" (168)
-------------------------	---	---------------------------	---	---

\* Dimensions in parentheses are in millimeters.

• **Clear Opening** formulas provide dimensions for determining area available for egress. **Vent Opening** formulas provide dimensions for determining area available for passage of air. **Minimum R.O.** (minimum rough opening) formulas provide minimum rough opening width and height dimensions. **Unobstr. Glass** (unobstructed glass) formulas provide dimensions for determining area available for passage of light.

**Grille Patterns**

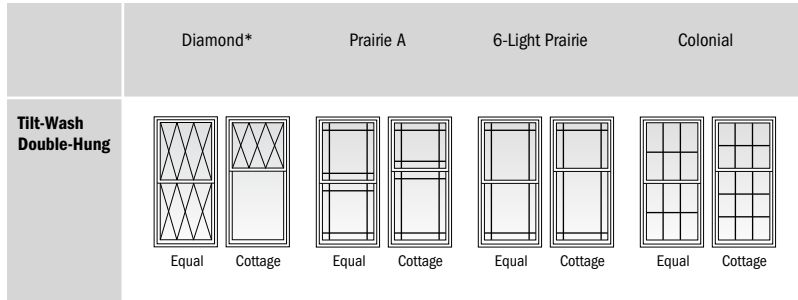

Patterns for double-hung windows are also available in Upper Sash Only (USO) configurations. For picture window patterns that require alignment with double-hung window patterns, identify the sash style (equal, cottage or reverse cottage) when ordering. **Number of lights and overall pattern varies with window size. Patterns are not available in all configurations.**

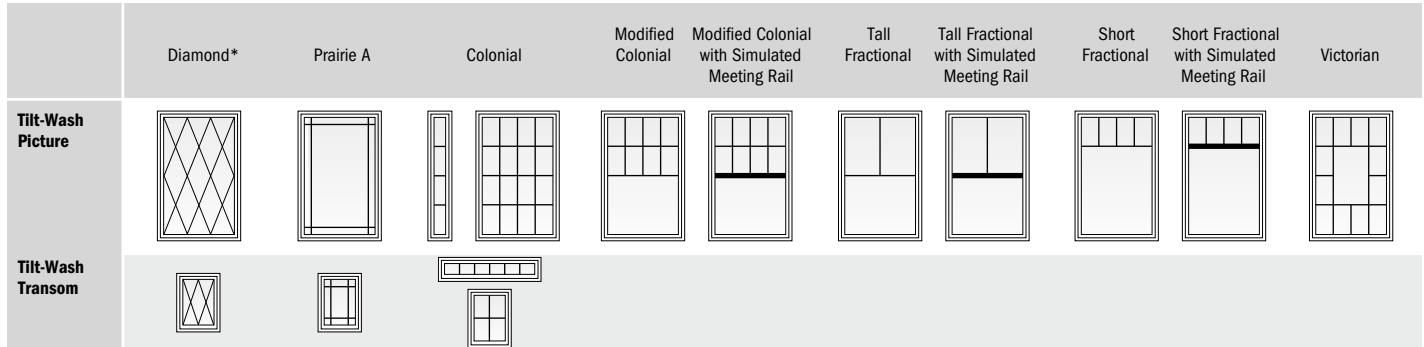

\*Available only in Simulated Divided Light (SDL) configuration and only in 3/4" (19) and 7/8" (22) widths.

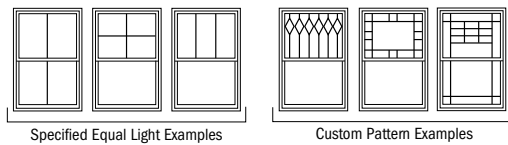

Specified equal light and custom patterns are also available. For more grille options, see page 13 or visit [andersenwindows.com/grilles](http://andersenwindows.com/grilles).

**Tilt-Wash Double-Hung Window Details**

Scale 1 1/2" (38) = 1'-0" (305) – 1:8

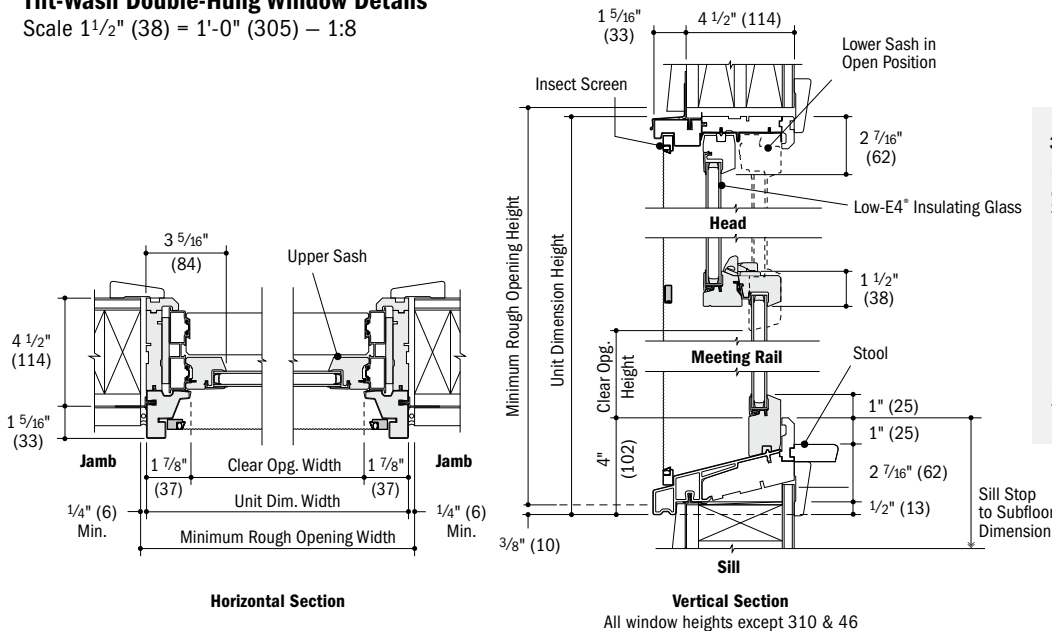

**310 & 46 Height Windows Only:**

Upper Sash Meeting Rail (higher location on 310 and 46 heights)

Lower Sash in Open Position (opens higher to maintain clear opening)

Meeting Rail

Note: Location of support bar on optional insect screen aligns with meeting rail location on 310 and 46 window heights.

400 Series  
Tilt-Wash Double-Hung  
Full-Frame Windows

- Light-colored areas are parts included with window. Dark-colored areas are additional Andersen® parts required to complete window assembly as shown.
- **Rough openings may need to be increased to allow for use of building wraps, flashing, sill panning, brackets, fasteners or other items. See installation information on pages 210-211.**
- Details are for illustration only and are not intended to represent product installation methods or materials. Refer to product installation guides at [andersenwindows.com](http://andersenwindows.com).
- Dimensions in parentheses are in millimeters.

# TILT-WASH DOUBLE-HUNG FULL-FRAME WINDOWS

## Tilt-Wash Picture Window Details

Scale 1 1/2" (38) = 1'-0" (305) – 1:8

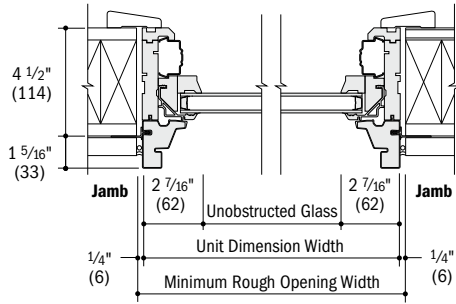

Horizontal Section

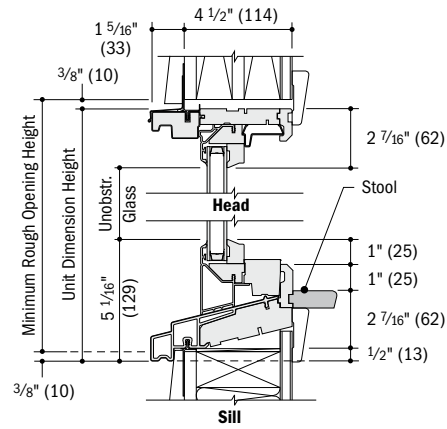

Vertical Section

## Tilt-Wash Transom Window Details

Scale 1 1/2" (38) = 1'-0" (305) – 1:8

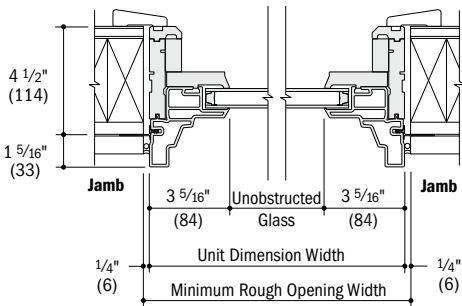

Horizontal Section

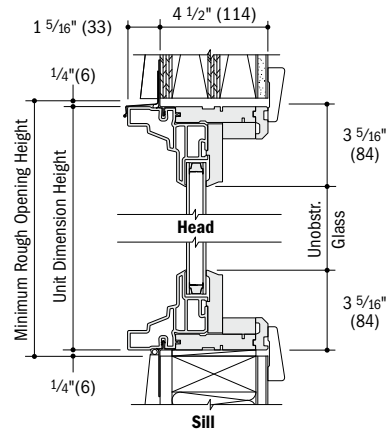

Vertical Section

## Horizontal (stack) Joining Detail

Scale 1 1/2" (38) = 1'-0" (305) – 1:8

### Overall Window Dimension Height

Sum of individual window heights  
plus 1/16" (1.5) for each join.

### Overall Rough Opening Height

Overall window dimension height.\*

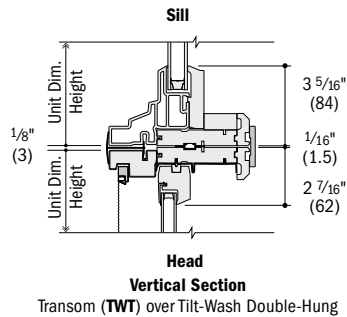

Head  
Vertical Section  
Transom (TWT) over Tilt-Wash Double-Hung

## Vertical (ribbon) Joining Detail

Scale 1 1/2" (38) = 1'-0" (305) – 1:8

### Overall Window Dimension Width

Sum of individual window widths  
plus 1/16" (1.5) for each join.

### Overall Rough Opening Width

Overall window dimension width plus 1/2" (13).

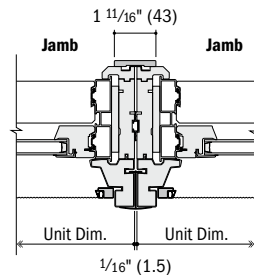

Horizontal Section  
Tilt-Wash Double-Hung to Tilt-Wash Double-Hung

## Separate Rough Openings Detail

Scale 1 1/2" (38) = 1'-0" (305) – 1:8

To meet structural requirements or to achieve a wider joined appearance, windows may be installed into separate rough openings having vertical support (by others) in combination with Andersen® exterior filler and exterior vinyl trim.

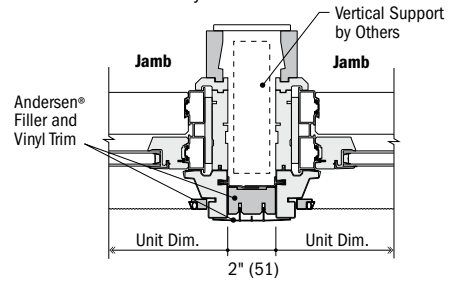

Horizontal Section  
Tilt-Wash Double-Hung and Tilt-Wash Double-Hung

- \* Light-colored areas are parts included with window. Dark-colored areas are additional Andersen® parts required to complete window assembly as shown.
- \* Rough openings may need to be increased to allow for use of building wraps, flashing, sill panning, brackets, fasteners or other items. See installation information on pages 210-211.
- \* Details are for illustration only and are not intended to represent product installation methods or materials. Refer to product installation guides at andersenwindows.com.
- \* Consult with an architect or structural engineer regarding minimum requirements for structural support members between adjacent rough openings.
- \* Dimensions in parentheses are in millimeters.
- \* For stacks where bottom unit in combination is a double-hung or picture window with a sloped sill. If bottom window has a straight sill add 1/2" (13) to the overall window dimension height.

## NARROLINE® CONVERSION KIT

Narroline double-hung window conversion kits are designed specifically to update existing Narroline windows (made from 1968 to 2013) to tilt-wash windows. They provide quick and easy installation with less mess than traditional window replacement, because there are no window frame tear-out or trim modifications.

Each kit includes:

- Upper and lower sash with your choice of Low-E4® glass options
- Jamb liners
- Balancers
- Lock and keeper

### Glass

High-Performance glass options include:

- Low-E4 glass
- Low-E4 HeatLock® glass
- Low-E4 Sun glass
- Low-E4 SmartSun™ glass
- Low-E4 SmartSun HeatLock glass

Tempered glass and other glass options are available. Contact your Andersen supplier.

A removable translucent film helps shield the glass from damage during delivery and installation and simplifies finishing at the jobsite.

High-Performance Low-E4 glass is 45% more energy-efficient than ordinary dual-pane glass in winter and 56% more energy-efficient in summer.\*

### Low Maintenance

Sash tilt inward for easy cleaning of window exteriors from inside the home (no need for ladders).



See videos of Narroline double-hung window conversion kit features and installation at [andersenwindows.com/narroline](http://andersenwindows.com/narroline).

### EXTERIOR



White Sandtone Terratone

### INTERIOR



Pine White

Naturally occurring variations in grain, color and texture of wood make each window one of a kind. All wood interiors are unfinished unless prefinished white is specified.

## STORM/INSECT SCREEN COMBINATION UNIT

For product information, see page 48 for 400 Series Woodwright® double-hung windows or page 77 for 400 Series tilt-wash double-hung windows.

\* Values are based on comparison of Andersen® double-hung window conversion kit U-Factor to the U-Factor for clear dual-pane glass non-metal frame default values from the 2006, 2009, 2012, 2015 and 2018 International Energy Conservation Code "Glazed Fenestration" Default Tables

\*\* Unobstructed Glass Height dimensions in table are for lower sash only.

Dimensions in parentheses are in millimeters.

Printing limitations prevent exact replication of colors and finishes. See your Andersen supplier for actual color and finish samples.

## Narroline Double-Hung Window Identification

Unobstructed Glass Width Inches/(mm)	Unobstructed Glass Height** Inches/(mm)	Window Number
16 7/16" (418)	13 15/16" (354)	18210
16 7/16" (418)	15 15/16" (405)	1832
16 7/16" (418)	19 15/16" (506)	18310
16 7/16" (418)	21 15/16" (557)	1842
16 7/16" (418)	23 15/16" (608)	1846
16 7/16" (418)	27 15/16" (710)	1852
16 7/16" (418)	35 15/16" (913)	1856
16 7/16" (418)	33 15/16" (862)	1862
20 7/16" (519)	13 15/16" (354)	20210
20 7/16" (519)	15 15/16" (405)	2032
20 7/16" (519)	19 15/16" (506)	20310
20 7/16" (519)	21 15/16" (557)	2042
20 7/16" (519)	23 15/16" (608)	2046
20 7/16" (519)	27 15/16" (710)	2052
20 7/16" (519)	35 15/16" (913)	2056
20 7/16" (519)	33 15/16" (862)	2062
24 7/16" (621)	13 15/16" (354)	24210
24 7/16" (621)	15 15/16" (405)	2432
24 7/16" (621)	19 15/16" (506)	24310
24 7/16" (621)	21 15/16" (557)	2442
24 7/16" (621)	23 15/16" (608)	2446
24 7/16" (621)	27 15/16" (710)	2452
24 7/16" (621)	35 15/16" (913)	2456
24 7/16" (621)	33 15/16" (862)	2462
28 7/16" (722)	13 15/16" (354)	28210
28 7/16" (722)	15 15/16" (405)	2832
28 7/16" (722)	19 15/16" (506)	28310
28 7/16" (722)	21 15/16" (557)	2842
28 7/16" (722)	23 15/16" (608)	2846
28 7/16" (722)	27 15/16" (710)	2852
28 7/16" (722)	35 15/16" (913)	2856
28 7/16" (722)	33 15/16" (862)	2862
32 7/16" (824)	13 15/16" (354)	30210
32 7/16" (824)	15 15/16" (405)	3032
32 7/16" (824)	19 15/16" (506)	30310
32 7/16" (824)	21 15/16" (557)	3042
32 7/16" (824)	23 15/16" (608)	3046
32 7/16" (824)	27 15/16" (710)	3052
32 7/16" (824)	35 15/16" (913)	3056
32 7/16" (824)	33 15/16" (862)	3062
36 7/16" (926)	13 15/16" (354)	34210
36 7/16" (926)	15 15/16" (405)	3432
36 7/16" (926)	19 15/16" (506)	34310
36 7/16" (926)	21 15/16" (557)	3442
36 7/16" (926)	23 15/16" (608)	3446
36 7/16" (926)	27 15/16" (710)	3452
36 7/16" (926)	35 15/16" (913)	3456
36 7/16" (926)	33 15/16" (862)	3462
40 7/16" (1027)	13 15/16" (354)	38210
40 7/16" (1027)	15 15/16" (405)	3832
40 7/16" (1027)	19 15/16" (506)	38310
40 7/16" (1027)	21 15/16" (557)	3842
40 7/16" (1027)	23 15/16" (608)	3846
40 7/16" (1027)	27 15/16" (710)	3852
40 7/16" (1027)	35 15/16" (913)	3856
40 7/16" (1027)	33 15/16" (862)	3862

# NOTES

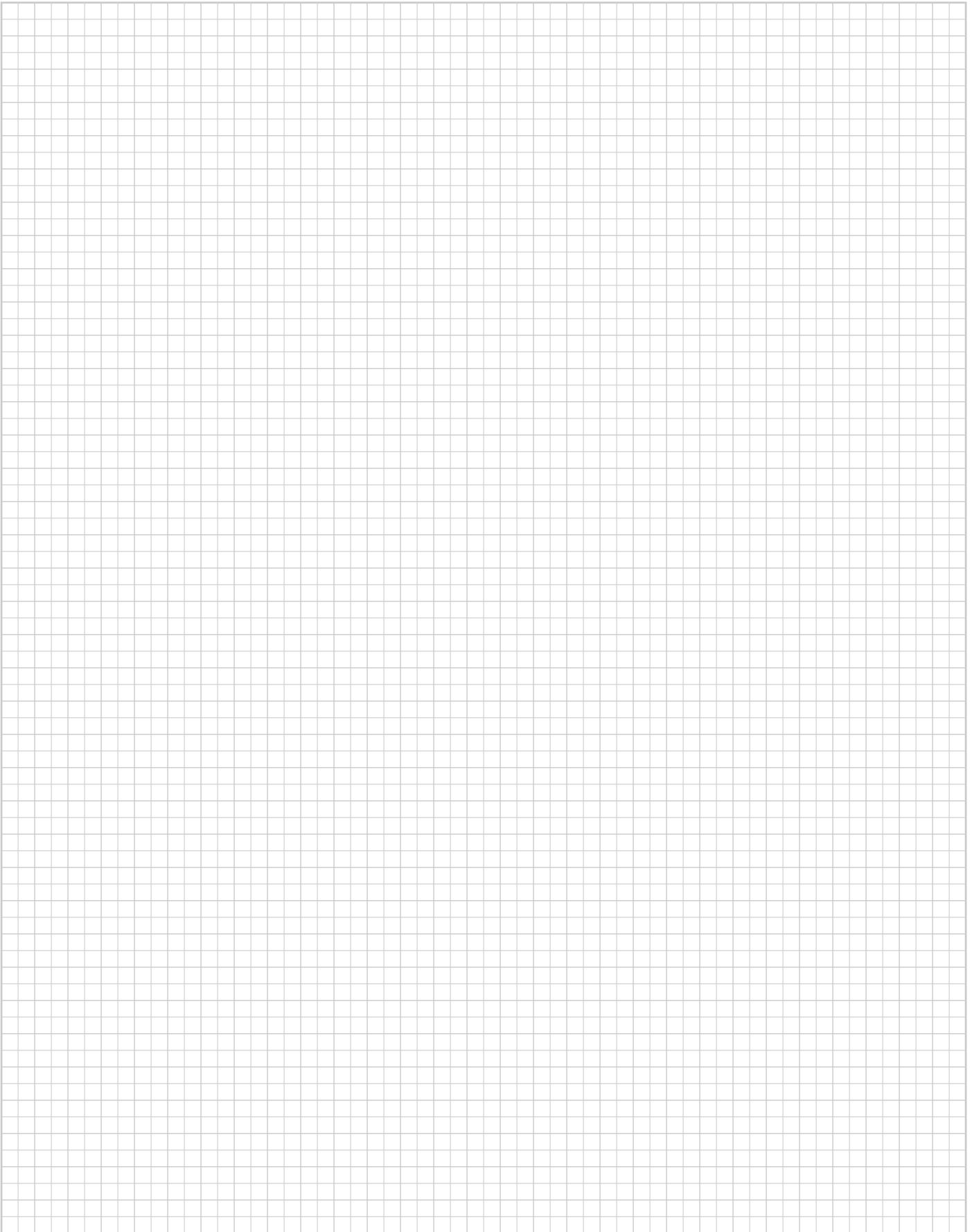

# TILT-WASH DOUBLE-HUNG INSERT WINDOWS



## SECTION REFERENCE

Custom Sizing .....	92
Specifications .....	92
Existing Window Measurements .....	93
Sill Angle Details .....	93
Grille Patterns .....	94
Window Details .....	94-95
Joining Detail .....	95
Product Performance .....	194

### CUSTOM SIZING

in 1/8" (3) increments



Dimensions in parentheses are in millimeters.

# TILT-WASH DOUBLE-HUNG INSERT WINDOWS

## FEATURES

### Frame

**A** Fibrex® material exterior protects the frame – beautifully. Best of all, it's low maintenance and never needs painting.\*

**B** For exceptional long-lasting performance, sill members are constructed with a wood core and a Fibrex material exterior. Sill ends are protected and sealed with weather-resistant covers.

**C** Natural wood stops are available in pine and prefinished white, dark bronze and black.\*\*

**D** Weatherstrip throughout the unit provides a long-lasting, energy-efficient, weather-resistant seal. For the top and bottom rails, an encased foam material is used. The head jamb liner and sill have a rigid vinyl rib that the weatherstrip material compresses against. At the meeting rail, compressible vinyl bulb material is used. Side jamb liners use leaf-type weatherstrip with foam inserts.

**E** Exterior stop covers are specially designed to allow easy application of high-quality sealant.

3 1/4" (83) "pocket window" jamb depth allows convenient replacement without disturbing interior window trim for most double-hung replacement situations.

**F** Jamb liners available in white or gray and must be specified when ordering. Contact your Andersen supplier for details.



Unique block-and-tackle balancers feature sized-to-the-unit, rust-resistant springs that require no adjustment. Glass-reinforced nylon balancer shoes provide smooth, reliable sash operation. They automatically lock the balancer into position when sash are tilted into wash mode.

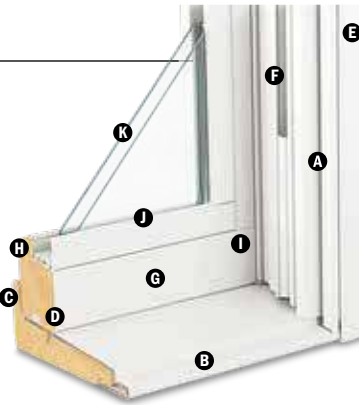

### Sash

Wash assists make it easy to tilt the sash into wash mode.

**G** A polyester-stabilized coat with a Flexacron® finish is electrostatically applied to penetrate all exterior surfaces for maximum protection and a lustrous finish.

**H** Wood sash members are treated with a water-repellent preservative for long-lasting protection and performance. Interior surfaces are unfinished pine. Low-maintenance prefinished white interiors are also available.

**I** Sash joints simulate the look of traditional mortise-and-tenon construction inside and out.

### Glass

**J** Silicone bed glazing provides superior weathertightness and durability.

**K** High-Performance glass options include:

- Low-E4® glass
- Low-E4 HeatLock® glass
- Low-E4 Sun glass
- Low-E4 SmartSun™ glass
- Low-E4 SmartSunHeatLock glass

Tempered glass and other glass options are available. Contact your Andersen supplier.

A removable translucent film helps shield the glass from damage during delivery and construction and simplifies finishing at the jobsite.

### Patterned Glass

Patterned glass options are available. See page 12 for more details.

## EXTERIOR



## INTERIOR

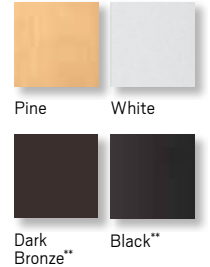

Naturally occurring variations in grain, color and texture of wood make each window one of a kind. All wood interiors are unfinished unless a prefinished option is specified.

## HARDWARE FINISHES



Distressed bronze and oil rubbed bronze are "living" finishes that will change with time and use.

## DOUBLE-HUNG HARDWARE

### STANDARD

#### Lock & Keeper



Black | Gold Dust | **Stone** | White  
Stone is standard with natural interior units. White comes with prefinished white interiors. Other finishes optional.

## OPTIONAL DOUBLE-HUNG HARDWARE\*\*

### ESTATE™

#### Lock & Keeper



Optional Estate lock & keeper reduces the clear opening height by 3/16" (14). Check with local building code officials to determine compliance with egress requirements.

### CONTEMPORARY

#### Bar Lift



Antique Brass | Black | Bright Brass  
Brushed Chrome | Distressed Bronze  
**Distressed Nickel** | Gold Dust  
Oil Rubbed Bronze | Polished Chrome  
Satin Nickel | Stone | White

### TRADITIONAL

#### Bar Lift



#### Hand Lift



#### Finger Lifts



Antique Brass | Black | Bright Brass | Brushed Chrome | Distressed Bronze | Distressed Nickel  
Gold Dust | **Oil Rubbed Bronze** | Polished Chrome | Satin Nickel | Stone | White

Bold name denotes finish shown.

\* Visit andersenwindows.com/warranty or for details.

\*\* Dark bronze and black interiors are only available with dark bronze and black exteriors respectively.

"Flexacron" is a registered trademark of PPG Industries, Inc.

Dimensions in parentheses are in millimeters.

Printing limitations prevent exact replication of colors and finishes. See your Andersen supplier for actual color and finish samples.

### Sill Angles

Three sill angles are available — 0°, 8° and 14° — to closely match the existing sill in window replacement applications. See page 93 for details.



0° Sill Angle



8° Sill Angle



14° Sill Angle

### Sill Angle Finder App

Our Sill Angle Finder App lets you quickly and easily find the sill angle of existing double-hung windows. Available for free for both iPhone® and Android™ smartphones. Download app for iPhone from the App Store<sup>SM</sup> or for Android smartphones from the Google Play Store. The app is only available for smartphones, as tablets and other large devices are too bulky for measuring window sill angles.

For more information about **glass, patterned glass, art glass, grilles and TruScene insect screens**, see pages 12-14.

For more information about **combination designs, product performance, installation instructions and accessories**, see pages 181-211 or visit [andersenwindows.com](http://andersenwindows.com).

### Exterior Stop Cover



An exterior stop cover provides a clean transition from new window to the existing window casing.

### Included Installation Materials



Flat, self-hanging shims, backer rod, installation screws and complete instructions are included with each insert window. Measurement guide and worksheet at [andersenwindows.com/measure](http://andersenwindows.com/measure).

### Sash Options\*



Cottage

Reverse Cottage

## ACCESSORIES Sold Separately

### Sash

#### Window Opening Control Device



A recessed window opening control device is available factory applied. It limits the sash travel to less than 4" (102) when the window is first opened. Available in stone, white and black. A field-applied window control opening device is also available.

### Installation

#### Coil Stock



Andersen® aluminum coil stock can be ordered to match any of our 11 trim colors. Made from .018" thick aluminum, Andersen coil stock is available in 24" (610) x 50' (15240) rolls. Color-matched stainless steel trim nails 1 1/4" (32) long are also available and can be ordered in 1 lb/.454 kg boxes.

### Security Sensors

#### VeriLock® Sensors

VeriLock sensors are available in five colors. See page 15 for details.

#### Open/Closed Sensors

Wireless open/closed sensors are available in four colors. See page 15 for details.

### Glass

#### Andersen Art Glass

Available for tilt-wash transom and picture units. Andersen art glass panels come in a variety of original patterns. See pages 173-174 for details on Andersen art glass. Visit [andersenwindows.com/artglass](http://andersenwindows.com/artglass) for details and pattern information.

### Insect Screens

#### Insect Screen Frames



Choose full insect screen or half insect screen. Half insect screen (shown above) allows ventilation without affecting the view through the upper sash. Frames are available in colors to match product exteriors.

#### TruScene® Insect Screen

Exclusive Andersen TruScene insect screens provide over 50% more clarity than our conventional insect screens for a beautiful unobstructed view. They allow more fresh air and sunlight in, while doing a better job of keeping out small insects.

#### Conventional Insect Screen

Conventional insect screens have charcoal powder-coated aluminum screen mesh.

### Grilles

Grilles are available in a variety of configurations and widths. For double-hung grille patterns, see page 94.

#### CAUTION:

- Painting and staining may cause damage to rigid vinyl.
- Do not paint 400 Series windows with white, canvas, Sandtone, forest green, dark bronze or black exterior colors.
- Andersen does not warrant the adhesion or performance of homeowner-applied paint over vinyl or other factory-coated surfaces.
- 400 Series windows in Terratone color may be painted any color lighter than Terratone color using quality oil-based or latex paint.
- For vinyl painting instructions and preparation, contact your Andersen supplier.
- Do not paint weatherstrip.
- Creosote-based stains should not come in contact with Andersen products.
- Abrasive cleaners or solutions containing corrosive solvents should not be used on Andersen products.

\* Shown on 400 Series tilt-wash double-hung full-frame windows. Dimensions in parentheses are in millimeters.

"iPhone" and "App Store" are registered trademarks of Apple Inc. "Android" is a trademark of Google Inc.

# TILT-WASH DOUBLE-HUNG INSERT WINDOWS

## Tilt-Wash Double-Hung, Picture & Transom Insert Window Sizes

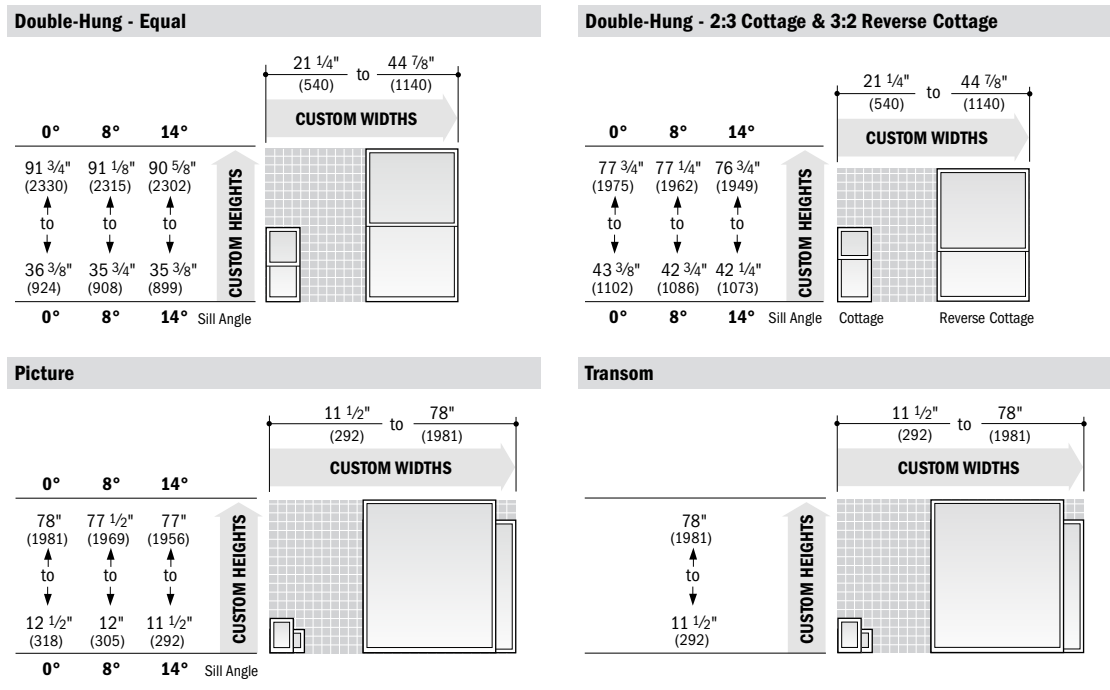

Available in 1/8" (3) increments between minimum and maximum widths and heights. Height limits for double-hung and picture insert windows depend on new insert window sill angle.

**For picture and transom insert windows, either height or width must be 68" (1727) or less and height plus width cannot be less than 28" (711).**

Measurement guide for custom sized windows can be found at [andersenwindows.com/measure](http://andersenwindows.com/measure). Grille patterns shown on page 94.

## Tilt-Wash Double-Hung Insert Window Specification Formulas

Vent Opening	Width = window width - 3.798" (96)				
	Height = Depends on sash ratio and specific sill angle of insert window, see below.				
	sash ratio	clear opening height	sill angle deduction		
			14°	8°	0°
	1:1 Equal	= (window height ÷ 2) - sill angle deduction	3.602" (91)	3.836" (97)	4.138" (105)
2:3 Cottage	= (window height x 2) ÷ 5 - sill angle deduction	2.879" (73)	3.066" (78)	3.308" (84)	
3:2 Reverse Cottage	= (window height x 2) ÷ 5 - sill angle deduction	2.083" (53)	2.270" (58)	2.512" (64)	
Unobstr. Glass	Width = window width - 6.219" (158)				
	Height = Depends on sash ratio and specific sill angle of insert window, see below.				
	sash	unobstructed glass height	sill angle deduction		
			14°	8°	0°
	Equal Upper and Lower Sash	= (window height ÷ 2) - sill angle deduction	3.625 (92)	3.844" (98)	4.156" (106)
Cottage Upper Sash or Reverse Cottage Lower Sash	= (window height x 2) ÷ 5 - sill angle deduction	2.891" (73)	3.078" (78)	3.328" (85)	
Cottage Lower Sash or Reverse Cottage Upper Sash	= (window height x 2) ÷ 5 - sill angle deduction	4.344" (110)	4.625" (117)	4.984" (127)	

**Optional Estate™ hardware will reduce vent opening height by 7/32" (6).**

For clear opening specifications, contact your Andersen supplier.

## Tilt-Wash Picture and Transom Insert Window Specifications

Unobstr. Glass	Picture Insert		Transom Insert		
	Width = window width - 6.0" (152)		Width = window width - 6.0" (152)		
	Height = Depends on sash ratio and specific sill angle of insert window, see below.		Height = window width - 6.0" (152)		
	unobstructed glass height	sill angle deductions			
		14°	8°	0°	
	= window height - sill angle deduction	5.816" (148)	6.285" (160)	6.890" (175)	

\* Dimensions in parentheses are in millimeters.  
 \* **Clear Opening** formulas provide dimensions for determining area available for egress. **Vent Opening** formulas provide dimensions for determining area available for passage of air. **Unobstr. Glass** (unobstructed glass) formulas provide dimensions for determining area available for passage of light.  
 \* Refer to [andersenwindows.com/measure](http://andersenwindows.com/measure) for detailed instructions on how to properly measure for insert windows.

## Existing Window Measurements

Required measurements:

1. Existing Opening Height
2. Existing Sill Angle
3. Existing Opening Width

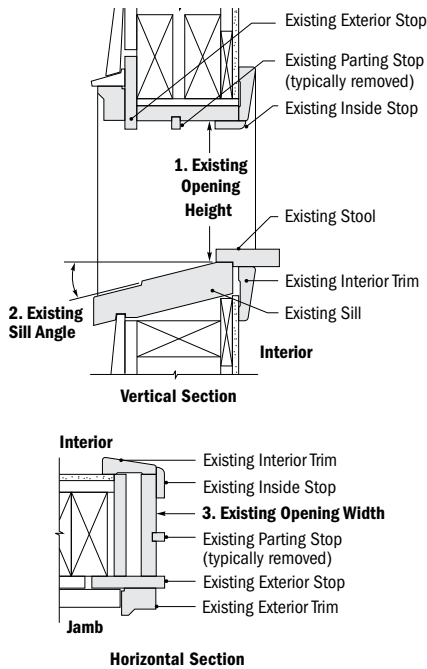

### Existing Double-Hung Window

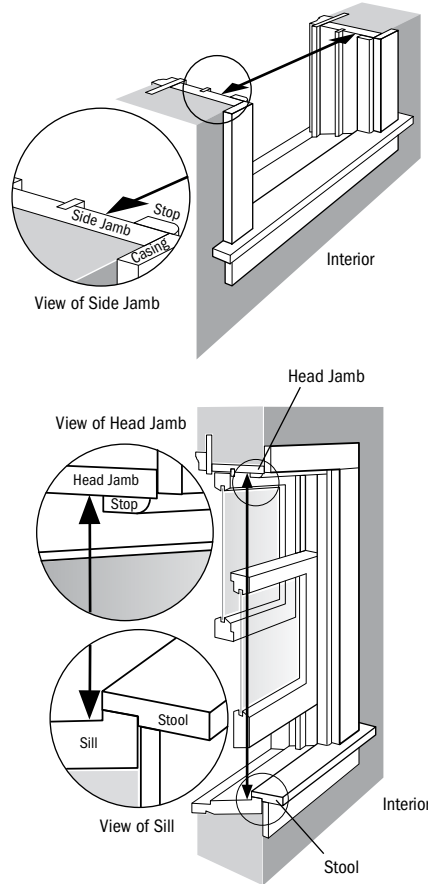

### Existing Picture Window

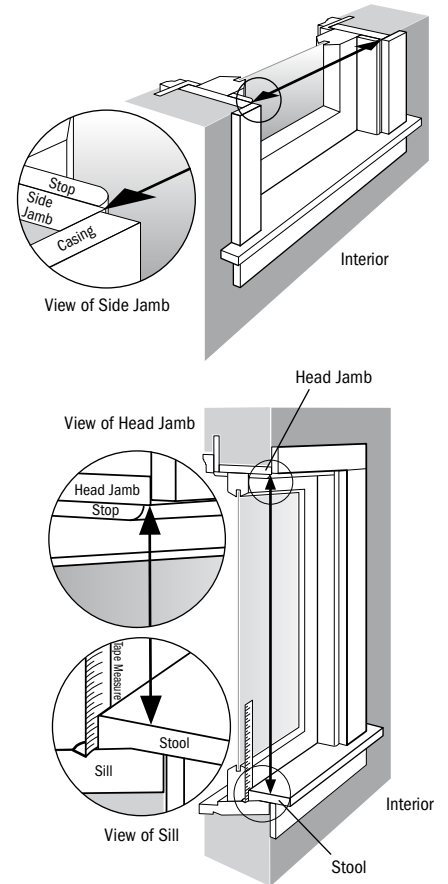

## Sill Angle Details

Scale 3" (76) = 1'-0" (305) – 1:4

Select a sill angle that most closely matches your existing sill angle.  
Windows with a smaller sill angle will have a larger maximum height.  
A "Sill Angle Finder App" is available, see page 91.

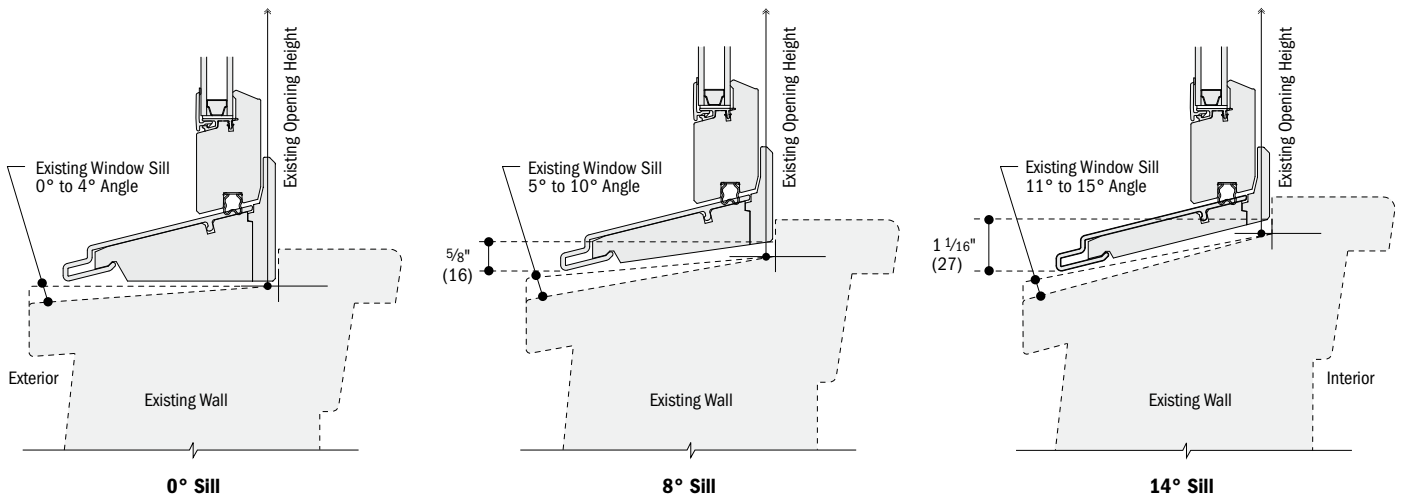

\*Details are for illustration only and are not intended to represent product installation methods or materials. Refer to product installation guides at andersenwindows.com.  
\*Dimensions in parentheses are in millimeters.  
\*Refer to andersenwindows.com/measure for detailed instructions on how to properly measure for insert windows.

# TILT-WASH DOUBLE-HUNG INSERT WINDOWS

## Grille Patterns

	Prairie A		Specified Equal Light			Prairie A		Specified Equal Light	
<b>Tilt-Wash Double-Hung Insert</b>					<b>Tilt-Wash Transom Insert</b>				
	Equal Sash	Cottage Sash	Equal Sash	Cottage Sash		<b>Tilt-Wash Picture Insert</b>			

Patterns for double-hung windows are also available in Upper Sash Only (USO) configurations. For picture window patterns that require alignment with double-hung window patterns, identify the sash style (equal, cottage, reverse cottage) when ordering. **Number of lights and overall pattern varies with window size. Patterns are not available in all configurations.** For more grille options, see page 13 or visit [andersenwindows.com/grilles](http://andersenwindows.com/grilles).

## Tilt-Wash Double-Hung Insert Window Details

Scale 1 1/2" (38) = 1'-0" (305) – 1:8

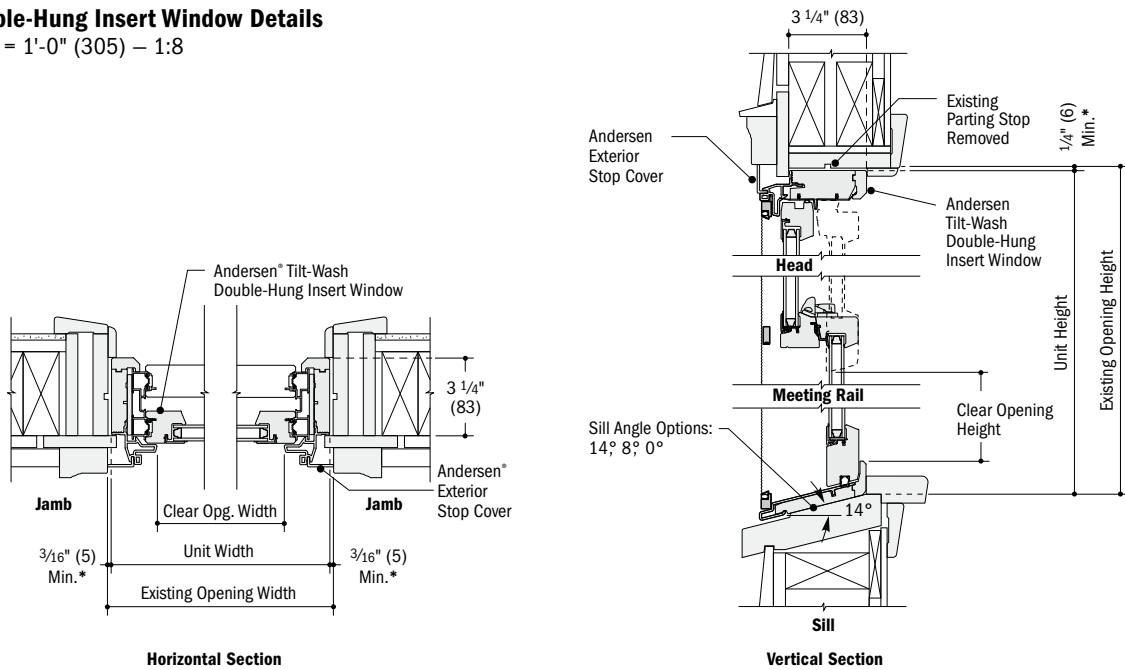

\* Light-colored areas are parts included with window. Dark-colored areas are additional Andersen® parts required to complete window assembly as shown.  
 \* Details are for illustration only and are not intended to represent product installation methods or materials. Refer to product installation guides at [andersenwindows.com](http://andersenwindows.com).  
 \* Dimensions in parentheses are in millimeters.  
 \* Refer to [andersenwindows.com/measure](http://andersenwindows.com/measure) for detailed instructions on how to properly measure for insert windows.

**Tilt-Wash Picture Insert Window Details**

Scale 1 1/2" (38) = 1'-0" (305) – 1:8

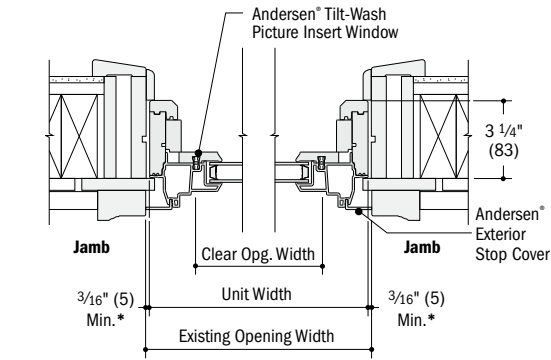

**Horizontal Section**

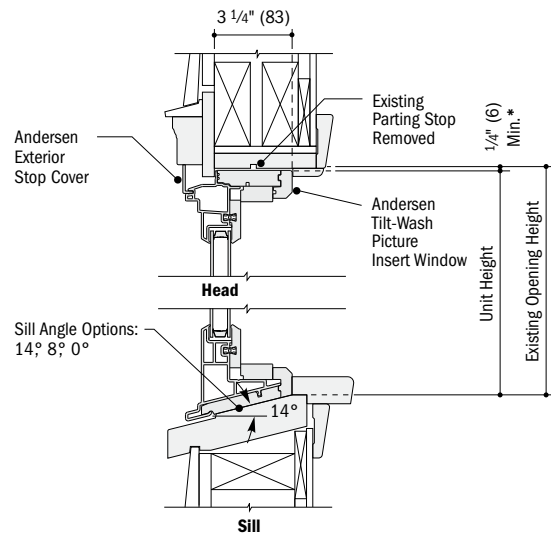

**Vertical Section**

**Tilt-Wash Transom Insert Window Details**

Scale 1 1/2" (38) = 1'-0" (305) – 1:8

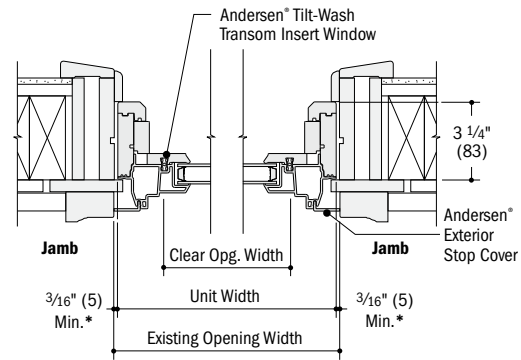

**Horizontal Section**

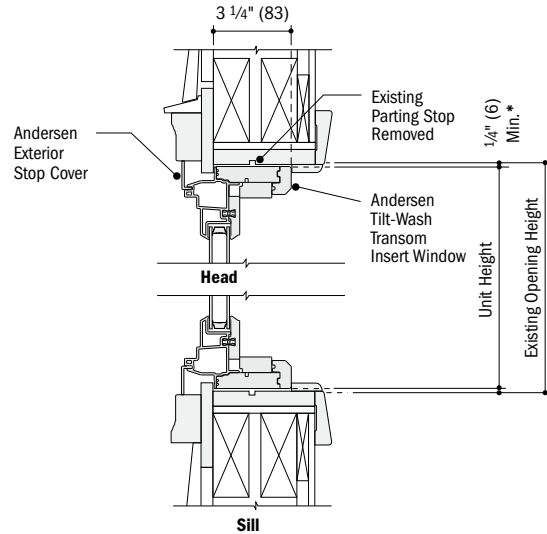

**Vertical Section**

**Joining Combinations**

Join insert windows in one-way combinations horizontally or vertically.

Do not join insert windows in two-way combinations.

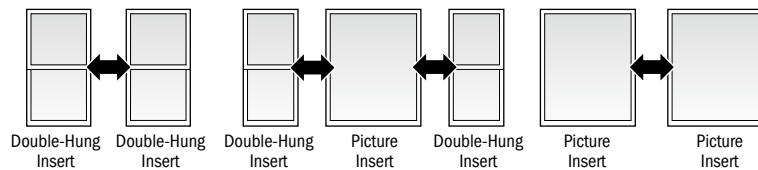
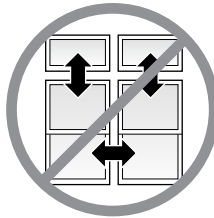
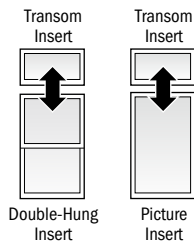

**Vertical (ribbon) Joining Detail**

Scale 1 1/2" (38) = 1'-0" (305) – 1:8

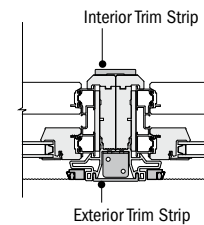

**Horizontal Section**

Tilt-Wash Double-Hung Insert to Tilt-Wash Double-Hung Insert

**For more joining information, see the combination designs section starting on page 181.**

\* Light-colored areas are parts included with window. Dark-colored areas are additional Andersen® parts required to complete window assembly as shown.  
\* Details are for illustration only and are not intended to represent product installation methods or materials. Refer to product installation guides at andersenwindows.com.  
\* Dimensions in parentheses are in millimeters.  
\* Refer to andersenwindows.com/measure for detailed instructions on how to properly measure for insert windows.

# NOTES

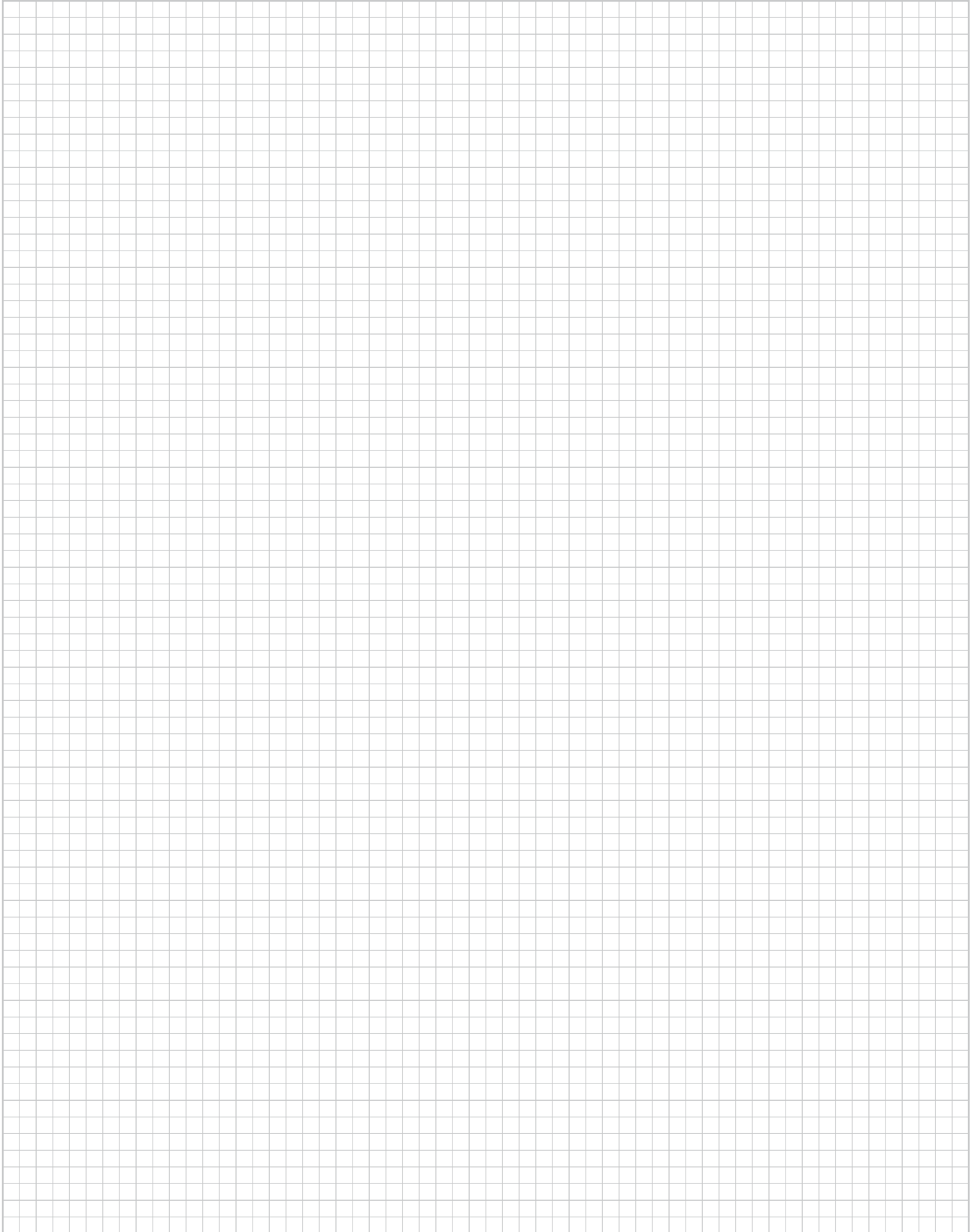

# BAY & BOW WINDOWS

400 Series  
Bay & Bow Windows



## SECTION REFERENCE

### Casement

Tables of Sizes .....	100-101
Window Details .....	102-103
Custom Sizes .....	104-105

### Double-Hung

Tables of Sizes .....	106-109
Window Details .....	110

### CUSTOM SIZING

in 1/8" (3) increments



Dimensions in parentheses are in millimeters.

# BAY & BOW WINDOWS

## FEATURES

### Casement Bay & Bow Windows

Constructed using basic casement windows. Some options must be specified to complete an order. These include color, glass and hardware.

**A** Pre-milled mullion posts join individual casement windows together into 30° angle bay, 45° angle bay, 90° box bay and 10° bow window units. Mullion posts lock into a channel in each adjoining casement window for a sturdy, easy-to-install unit. The exterior is sheathed with vinyl cladding; the interior is trimmed in natural wood, which can be finished to enhance any décor.

**B** Andersen® auxiliary casing is supplied as trim to finish the top of 30° angle bay, 45° angle bay and 10° bow windows. Auxiliary casing is an option for 90° box bay windows.

**C** Platforms made of 3/4" (19) plywood at the head and sill of bay and bow windows provide added strength to the assembly.

Custom bay and bow windows are available in a wide variety of unit configurations. See pages 104-105. Contact your Andersen supplier for details.



### Woodwright® & Tilt-Wash Double-Hung Bay Windows

Constructed using basic double-hung windows. Some options must be specified to complete an order. These include color and glass.

**D** Pre-milled mullion posts join individual units together into 30° angle bay and 45° angle bay window units for a sturdy, easy-to-install unit. The exterior is sheathed with vinyl cladding; the interior is trimmed in natural wood, which can be finished to enhance any décor.

**E** Andersen auxiliary casing is mitered, joined and installed as trim to finish the top of 30° and 45° angle bay windows. Cellular Fibrex® is covered in vinyl cladding.

**F** Platforms made of 3/4" (19) plywood at the head and sill of bay and bow windows provide added strength to the assembly.

Casement 30° Angle Bay Window

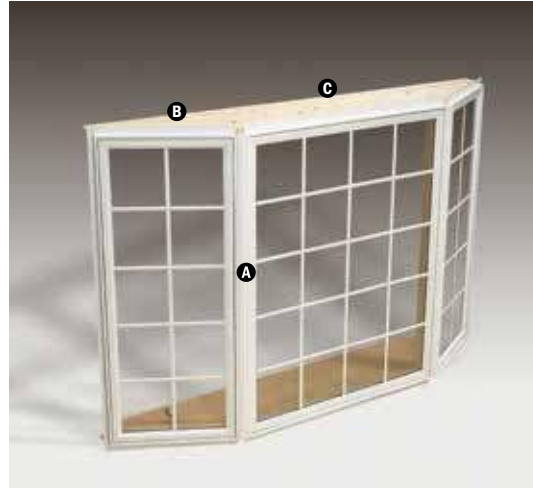

Double-Hung 45° Angle Bay Window



Casement 90° Box Bay Window



Casement 10° Bow Window

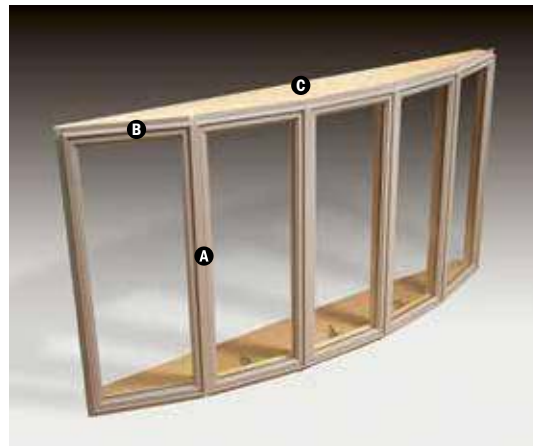

Dimensions in parentheses are in millimeters.

Installation of custom bay units having a projection greater than 24" (610) requires the expertise of a structural engineer to determine needed structural support. Failure to use sufficient structural support could result in personal injury or damage to windows or other property. Each cable within the system can support a maximum load of 500 lbs/227 kg. If the section of the window unit requiring support exceeds 1000 lbs/554 kg, additional support is needed.

**ACCESSORIES** Sold Separately. Please refer to the individual 400 Series product selections for a full list of options and accessories.

**Frame**

**Casement Extension Jamb  
and Extension Jamb Adaptors**

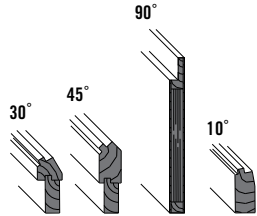

Extension jambs and extension jamb adaptors are available in unfinished pine and prefinished white, dark bronze or black.

For 30° and 45° bay windows, extension jambs are available in 1/8" (3) increments between 4 9/16" (116) and 7 1/8" (181). Some sizes may be veneered.

For box bay and bow windows, extension jambs are available in 1/16" (1.5) increments between 5 1/4" (133) and 7 1/8" (181). For wall depths less than 5 1/4" (133), order 5 1/4" (133) extension jambs and trim to fit.

**Casement Head and Seat Boards**

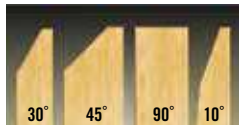

Head and seat boards are available in unfinished pine, oak, maple and prefinished white, dark bronze or black.

For 30° and 45° bay windows, head and seat boards are available in 1/16" (1.5) increments between 4 9/16" (116) and 7 1/8" (181).

For box bay and bow windows, head and seat boards are available in 1/16" (1.5) increments between 5 1/4" (133) and 7 1/8" (181). For wall depths less than 5 1/4" (133), order 5 1/4" (133) head and seat boards and trim to fit.

For more information about **glass, patterned glass, art glass, grilles and TruScene insect screens**, see pages 12-14.

For more information about **installation instructions and accessories**, see pages 210-211 or visit [andersenwindows.com](http://andersenwindows.com).

**Double-Hung Extension Jamb  
and Extension Jamb Adaptors**

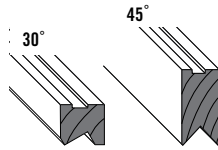

Extension jambs and extension jamb adaptors are available in unfinished pine and prefinished white, dark bronze or black.

Jamb depth of the unit plus extension jamb adaptor is 4 1/2" (114). Extension jambs are available in 1/16" (1.5) increments between 5 1/16" (129) and 7 1/8" (181). Some sizes may be veneered.

**Double-Hung Head and Seat Boards**

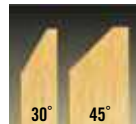

Head and seat boards are available in unfinished pine, oak, maple and prefinished white, dark bronze or black. Available in 1/16" (1.5) increments to match wall thicknesses between 5 1/4" (133) and 7 1/8" (181). Some sizes may be veneered.

**Installation**

**Cable Support**

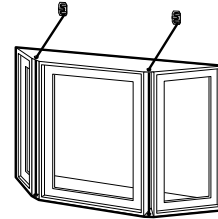

A cable provides additional support. Recommended for installations that extend out from the structure without a framed support wall beneath the unit. Each cable within the system can support a maximum load of 500 lbs/227 kg. If the section of the window unit requiring support exceeds 1000 lbs/554 kg, additional support is necessary. Failure to use sufficient structural support could result in personal injury or damage to windows or other property.

**⚠ WARNING**

**Proper support of projecting bow and bay windows is required, see installation instructions. Failure to do so may result in injury, product or property damage.**

**CAUTION:**

- Painting and staining may cause damage to rigid vinyl.
- Do not paint 400 Series windows with white, canvas, Sandtone, forest green, dark bronze or black exterior colors.
- Andersen does not warrant the adhesion or performance of homeowner-applied paint over vinyl or other factory-coated surfaces.
- 400 Series windows in Terratone color may be painted any color lighter than Terratone color using quality oil-based or latex paint.
- For vinyl painting instructions and preparation, contact your Andersen supplier.
- Do not paint weatherstrip.
- Creosote-based stains should not come in contact with Andersen products.
- Abrasive cleaners or solutions containing corrosive solvents should not be used on Andersen products.

# BAY & BOW WINDOWS

## Table of Casement 30° Angle Bay Windows

		Projection 13 3/4" (349)				
WIDTHS						
HEIGHTS	Bay Window Dimension	5'-10" (1778)	7'-9 7/8" (2384)	7'-9 7/8" (2384)	9'-9 3/4" (2991)	9'-9 3/4" (2991)
	Minimum Rough Opening	5'-9 1/8" (1756)	7'-9" (2362)	7'-9" (2362)	9'-8 7/8" (2969)	9'-8 7/8" (2969)
	3'-1 7/16" (951)	30-C13-20	30-C23-20	30-P4030-20	30-C33-20	30-P6030-20
	3'-2" (965)					
	3'-6 5/16" (1075)	30-C135-20	30-C235-20	30-P4035-20	30-C335-20	30-P6035-20
	3'-6 7/8" (1089)					
	4'-1 1/2" (1257)	30-C14-20	30-C24-20	30-P4040-20	30-C34-20	30-P6040-20
	4'-2" (1270)					
	4'-6 5/16" (1380)	30-C145-20	30-C245-20	30-P4045-20	30-C345-20	30-P6045-20
	4'-6 7/8" (1394)					
	5'-1 3/8" (1559)	30-C15-20	30-C25-20	30-P4050-20	30-C35-20	30-P6050-20
	5'-1 7/8" (1572)					
	5'-6 5/16" (1684)	30-C155-20	30-C255-20	30-P4055-20		
	5'-6 7/8" (1699)					
	6'-1 3/8" (1864)	30-C16-20	30-C26-20	30-P4060-20		
	6'-1 7/8" (1876)					

## Table of Casement 45° Angle Bay Windows

		Projection 19 3/16" (487)				
WIDTHS						
HEIGHTS	Bay Window Dimension	5'-4 1/8" (1629)	7'-3 7/8" (2232)	7'-3 7/8" (2232)	9'-3 3/4" (2838)	9'-3 3/4" (2838)
	Minimum Rough Opening	5'-2 5/8" (1591)	7'-2 1/2" (2197)	7'-2 1/2" (2197)	9'-2 3/8" (2804)	9'-2 3/8" (2804)
	3'-1 7/16" (951)	45-C13-20	45-C23-20	45-P4030-20	45-C33-20	45-P6030-20
	3'-2" (965)					
	3'-6 5/16" (1075)	45-C135-20	45-C235-20	45-P4035-20	45-C335-20	45-P6035-20
	3'-6 7/8" (1089)					
	4'-1 1/2" (1257)	45-C14-20	45-C24-20	45-P4040-20	45-C34-20	45-P6040-20
	4'-2" (1270)					
	4'-6 5/16" (1380)	45-C145-20	45-C245-20	45-P4045-20	45-C345-20	45-P6045-20
	4'-6 7/8" (1394)					
	5'-1 3/8" (1559)	45-C15-20	45-C25-20	45-P4050-20	45-C35-20	45-P6050-20
	5'-1 7/8" (1572)					
	5'-6 5/16" (1684)	45-C155-20	45-C255-20	45-P4055-20		
	5'-6 7/8" (1699)					
	6'-1 3/8" (1864)	45-C16-20	45-C26-20	45-P4060-20		
	6'-1 7/8" (1876)					

Custom-size windows are available in 1/8" (3) increments. See pages 104-105 for more information.



### ⚠ WARNING

Proper support of projecting bow and bay windows is required, see installation instructions. Failure to do so may result in injury, product or property damage.

In addition to venting shown in tables, other standard configurations are available. Choose left venting, right venting or stationary as viewed from the exterior.

- \* "Projection" refers to outside of the exterior sheathing to the outer edge of the window.
- \* "Window Dimension" always refers to outside frame to frame dimension.
- \* **"Minimum Rough Opening" dimensions may need to be increased to allow for use of building wraps, flashing, sill panning, brackets, fasteners or other items. See pages 210-211 for more details.**
- \* One Andersen cable kit, with two cables, is included with the unit for proper installation. Each cable supports a maximum load of 500 lbs/227 kg; additional support is necessary for loads exceeding 1000 lbs/454 kg.
- \* Angle bay and bow windows include only the basic unit. Roof and other installation materials provided by other manufacturers.
- \* For walkout angle bay and bow window details and installation guidelines, contact your Andersen supplier.
- \* Dimensions in parentheses are in millimeters.

**Table of Casement 90° Box Bay Windows**

		Projection 22 15/16" (583)		Projection 22 15/16" (583)		Projection 22 15/16" (583)		Projection 22 15/16" (583)	
<b>WIDTHS</b>									
<b>HEIGHTS</b>	Bay Window Dimension	4'-8 1/4" (1429)	4'-8 1/4" (1429)	6'-8 1/8" (2035)	6'-8 1/8" (2035)				
	<b>Minimum Rough Opening</b>	4'-1 5/8" (1260)	4'-1 5/8" (1260)	6'-1 1/2" (1867)	6'-1 1/2" (1867)				
	3'-1 7/16" (951)	90-C23-15	90-P4030-15	90-C33-15	90-P6030-15				
	3'-2" (965)								
	3'-6 5/16" (1075)	90-C235-15	90-P4035-15	90-C335-15	90-P6035-15				
	3'-6 7/8" (1089)								
	4'-1 1/2" (1257)	90-C24-15	90-P4040-15	90-C34-15	90-P6040-15				
	4'-2" (1270)								
	4'-6 5/16" (1380)	90-C245-15	90-P4045-15	90-C345-15	90-P6045-15				
	4'-6 7/8" (1394)								
	5'-1 3/8" (1559)	90-C25-15	90-P4050-15	90-C35-15	90-P6050-15				
	5'-1 7/8" (1572)								
	5'-6 5/16" (1684)	90-C255-15	90-P4055-15						
	5'-6 7/8" (1699)								
	6'-1 3/8" (1864)	90-C26-15	90-P4060-15						
	6'-1 7/8" (1876)								



Custom-size windows are available in 1/8" (3) increments. See pages 104-105 for more information.

In addition to venting shown in tables, other standard configurations are available. Choose left venting, right venting or stationary as viewed from the exterior.

**Table of Casement 10° Bow Windows**

		Projection 5 9/16" (141)		Projection 9 13/16" (249)		Projection 14" (356)		Projection 20 5/16" (516)		Projection 26 3/8" (670)	
<b>WIDTHS</b>											
<b>HEIGHTS</b>	Bow Window Dimension	6'-1 9/16" (1868)	8'-1 9/16" (2478)	10'-0 3/4" (3067)	11'-11 1/16" (3634)	13'-8 5/16" (4174)					
	<b>Minimum Rough Opening</b>	6'-1 5/8" (1862)	8'-1 3/8" (2473)	10'-0 3/8" (3058)	11'-10 1/2" (3620)	13'-7 1/2" (4153)					
	3'-1 7/16" (951)	<b>C33 BOW</b>	<b>C43 BOW</b>	<b>C53 BOW</b>	<b>C63 BOW</b>	<b>C73 BOW</b>					
	3'-2" (965)										
	3'-6 5/16" (1075)	<b>C335 BOW</b>	<b>C435 BOW</b>	<b>C535 BOW</b>	<b>C635 BOW</b>	<b>C735 BOW</b>					
	3'-6 7/8" (1089)										
	4'-1 1/2" (1257)	<b>C34 BOW</b>	<b>C44 BOW</b>	<b>C54 BOW</b>	<b>C64 BOW</b>	<b>C74 BOW</b>					
	4'-2" (1270)										
	4'-6 5/16" (1380)	<b>C345 BOW</b>	<b>C445 BOW</b>	<b>C545 BOW</b>	<b>C645 BOW</b>	<b>C745 BOW</b>					
	4'-6 7/8" (1394)										
	5'-1 3/8" (1559)	<b>C35 BOW</b>	<b>C45 BOW</b>	<b>C55 BOW</b>	<b>C65 BOW</b>	<b>C75 BOW</b>					
	5'-1 7/8" (1572)										
	5'-6 5/16" (1684)	<b>C355 BOW</b>	<b>C455 BOW</b>	<b>C555 BOW</b>	<b>C655 BOW</b>	<b>C755 BOW</b>					
	5'-6 7/8" (1699)										
	6'-1 3/8" (1864)	<b>C36 BOW</b>	<b>C46 BOW</b>	<b>C56 BOW</b>	<b>C66 BOW</b>	<b>C76 BOW</b>					
	6'-1 7/8" (1876)										

**⚠ WARNING**

Proper support of projecting bow and bay windows is required, see installation instructions. Failure to do so may result in injury, product or property damage.

- "Projection" refers to outside of the exterior sheathing to the outer edge of the window.
- "Window Dimension" always refers to outside frame to frame dimension.
- "Minimum Rough Opening" dimensions may need to be increased to allow for use of building wraps, flashing, sill panning, brackets, fasteners or other items. See pages 210-211 for more details.
- One Andersen cable kit, with two cables, is included with the unit for proper installation. Each cable supports a maximum load of 500 lbs/227 kg; additional support is necessary for loads exceeding 1000 lbs/454 kg.
- Angle bay and bow windows include only the basic unit. Roof and other installation materials provided by other manufacturers.
- For walkout angle bay and bow window details and installation guidelines, contact your Andersen supplier.
- Dimensions in parentheses are in millimeters.

# BAY & BOW WINDOWS

## Casement 30° Angle Bay Window Detail

Scale 1 1/2" (38) = 1'-0" (305) – 1:8

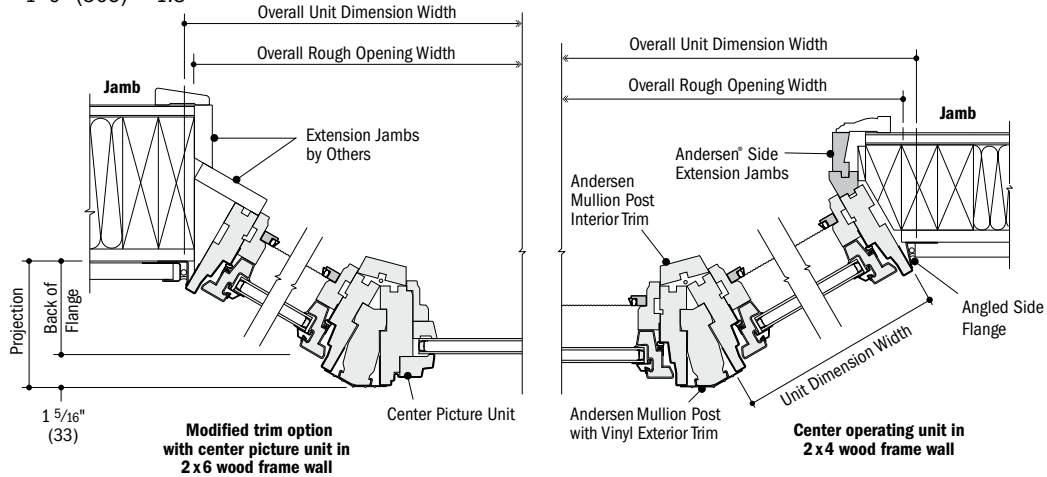

Horizontal Section

## Casement 45° Angle Bay Window Detail

Scale 1 1/2" (38) = 1'-0" (305) – 1:8

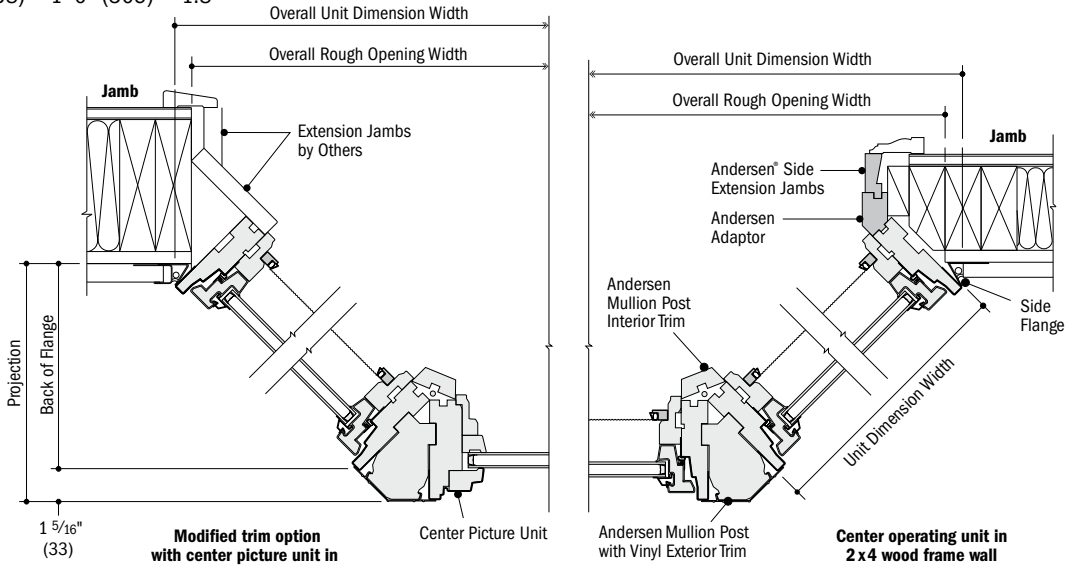

Horizontal Section

## Casement 10° Bow Window Detail

Scale 1 1/2" (38) = 1'-0" (305) – 1:8

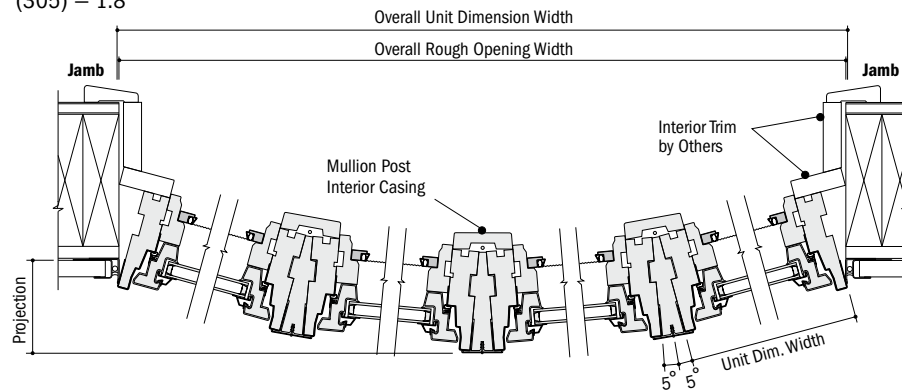

Horizontal Section

\* Light-colored areas are parts included with window. Dark-colored areas are additional Andersen® parts required to complete window assembly as shown.  
 \* Rough openings may need to be increased to allow for use of building wraps, flashing, sill panning, brackets, fasteners, or other items. See installation information on pages 210-211.  
 \* Details are for illustration only and are not intended to represent product installation methods or materials. Refer to unit installation guides at andersenwindows.com.  
 \* Dimensions in parentheses are in millimeters.

**Casement 90° Box Bay Window Details**

Scale 1 1/2" (38) = 1'-0" (305) – 1:8

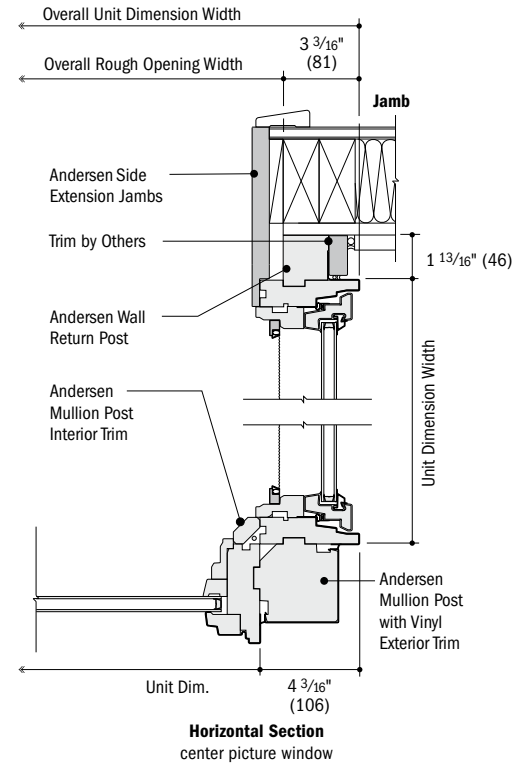
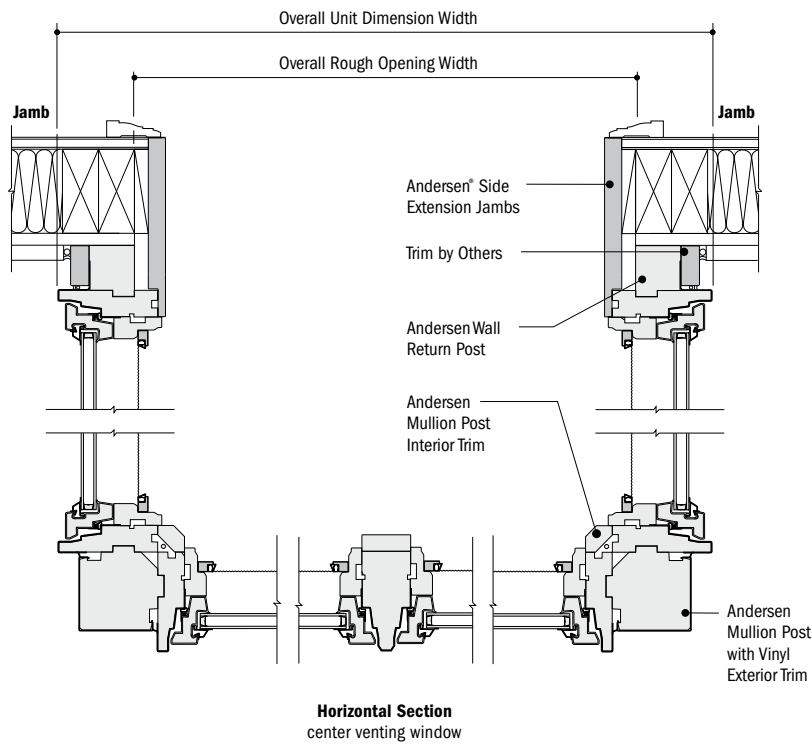

**Casement 30° & 45° Angle Bay, 10° Bow & 90° Box Bay Window Detail**

Scale 1 1/2" (38) = 1'-0" (305) – 1:8

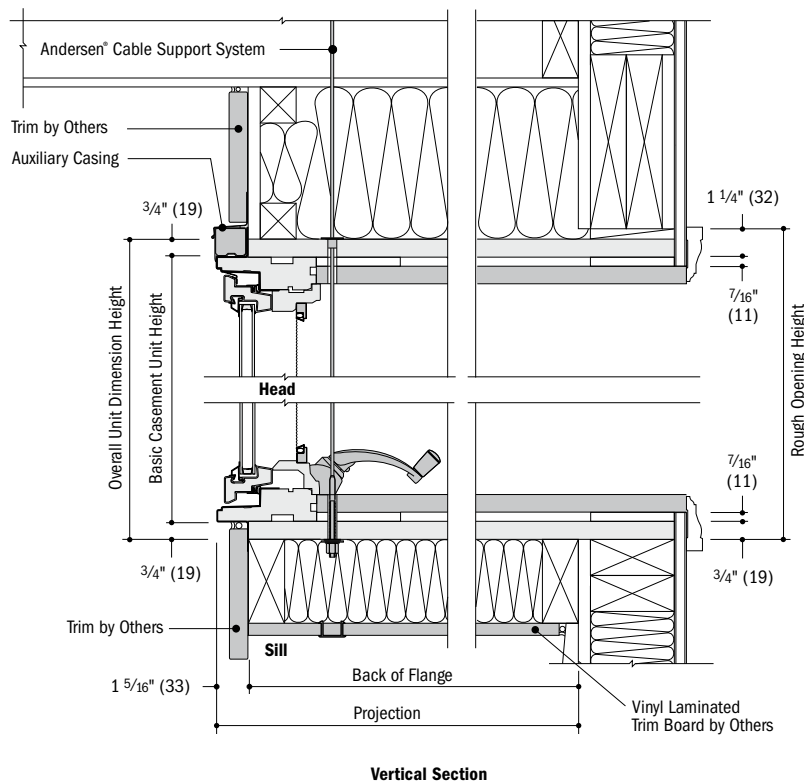

\* Light-colored areas are parts included with window. Dark-colored areas are additional Andersen® parts required to complete window assembly as shown.  
 • Rough openings may need to be increased to allow for use of building wraps, flashing, sill panning, brackets, fasteners or other items. See installation information on pages 210-211.  
 • Details are for illustration only and are not intended to represent product installation methods or materials. Refer to unit installation guides at andersenwindows.com.  
 • Dimensions in parentheses are in millimeters.

# BAY & BOW WINDOWS











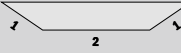

Individual window units are available custom sized in 1/8" (3) increments.

In addition to venting shown in tables, other standard configurations are available.





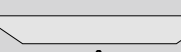



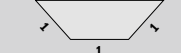

Choose left venting, right venting or stationary as viewed from the exterior.

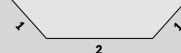
Measurement guide can be found at [andersenwindows.com/measure](http://andersenwindows.com/measure).

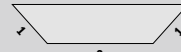
## Custom Casement 30° Angle Bay Window Size and Projection Range

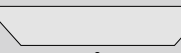
Sash Ratio Window Configuration	Center Window Venting Configuration	Bay Window Dimension				Projection		
		Minimum Width Inches/(mm)	Maximum Width Inches/(mm)	Minimum Height Inches/(mm)	Maximum Height Inches/(mm)	Minimum Inches/(mm)	Maximum Inches/(mm)	
1:1:1 	Venting or Stationary 	50" (1270)	101 1/2" (2578)	X	26 1/8" (664)	73 7/8" (1876)	10 1/4" (260)	19 5/8" (498)
1:2:1 	Venting or Stationary 	67 3/8" (1711)	137 1/2" (3493)	X	26 1/8" (664)	73 7/8" (1876)	10 1/4" (260)	19 5/8" (498)
1:2:1 	Picture 	70 7/8" (1800)	115 1/4" (2927)	X	38" (965)	73 7/8" (1876)	10 3/4" (273)	16 5/8" (422)
		115 1/4" (2927)	137 5/8" (3496)	X	38" (965)	61 1/8" (1571)	16 5/8" (422)	19 5/8" (498)
1:3:1 	Venting or Stationary 	84 1/2" (2146)	144" (3658)	X	26 1/8" (664)	73 7/8" (1876)	10 1/4" (260)	16 1/2" (419)
1:3:1 	Picture 	83 7/8" (2130)	97 7/8" (2486)	X	38" (965)	73 7/8" (1876)	10 1/4" (260)	11 5/8" (295)
		97 7/8" (2486)	116 1/8" (2969)	X	38" (965)	61 1/8" (1571)	11 5/8" (295)	13 5/8" (346)

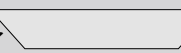
## Custom Casement 45° Angle Bay Window Size and Projection Range

Sash Ratio Window Configuration	Center Window Venting Configuration	Bay Window Dimension				Projection		
		Minimum Width Inches/(mm)	Maximum Width Inches/(mm)	Minimum Height Inches/(mm)	Maximum Height Inches/(mm)	Minimum Inches/(mm)	Maximum Inches/(mm)	
1:1:1 	Venting or Stationary 	45 3/4" (1162)	91 1/4" (2318)	X	26 1/8" (664)	73 7/8" (1876)	14 3/16" (360)	27 1/2" (699)
1:2:1 	Venting or Stationary 	63" (1600)	127 1/4" (3232)	X	26 1/8" (664)	73 7/8" (1876)	14 1/4" (362)	27 1/2" (699)
1:2:1 	Picture 	66" (1676)	106 7/8" (2715)	X	38" (965)	73 7/8" (1876)	14 7/8" (378)	23 1/4" (591)
		106 7/8" (2715)	127 1/4" (3232)	X	38" (965)	61 1/8" (1571)	23 1/4" (591)	27 1/2" (699)
1:3:1 	Venting or Stationary 	80 1/8" (2035)	144" (3658)	X	26 1/8" (664)	73 7/8" (1876)	14 1/4" (362)	24 5/16" (618)
1:3:1 	Picture 	79 5/8" (2023)	92 3/4" (2356)	X	38" (965)	73 7/8" (1876)	14 3/16" (360)	16 1/4" (413)
		92 3/4" (2356)	110 3/8" (2804)	X	38" (965)	61 1/8" (1571)	16 1/4" (413)	19" (483)

### ⚠ WARNING

Proper support of projecting bow and bay windows is required, see installation instructions. Failure to do so may result in injury, product or property damage.

\* "Projection" refers to outside of the exterior sheathing to the outer edge of the window.

\* "Window Dimension" always refers to outside frame to frame dimension.

\* **"Minimum Rough Opening" dimensions may need to be increased to allow for use of building wraps, flashing, sill panning, brackets, fasteners or other items. See pages 210-211 for more details.**

\* One Andersen cable kit, with two cables, is included with the unit for proper installation. Each cable supports a maximum load of 500 lbs/227 kg; additional support is necessary for loads exceeding 1000 lbs/454 kg.

\* Angle bay and bow windows include only the basic unit. Roof and other installation materials provided by other manufacturers.

\* For walkout angle bay and bow window details and installation guidelines, contact your Andersen supplier.

\* Refer to [andersenwindows.com/measure](http://andersenwindows.com/measure) for detailed instructions on how to properly measure for custom-size windows.

\* Dimensions in parentheses are in millimeters.



Individual window units are available custom sized in 1/8" (3) increments.

In addition to venting shown in tables, other standard configurations are available.

Choose left venting, right venting or stationary as viewed from the exterior.

Measurement guide can be found at [andersenwindows.com/measure](http://andersenwindows.com/measure).

**Custom Casement 90° Box Bay Window Size and Projection Range**

Window Configuration	Center Window Venting Configuration	Bay Window Dimension				Flanker		Projection		
		Minimum Width Inches/(mm)	Maximum Width Inches/(mm)	Minimum Height Inches/(mm)	Maximum Height Inches/(mm)	Minimum Width Inches/(mm)	Maximum Width Inches/(mm)	Minimum Depth Inches/(mm)	Maximum Depth Inches/(mm)	
	Picture	38 1/4" (972)	61 7/8" (1572)	X	38" (965)	73 7/8" (1876)	17" (432)	35 7/8" (911)	21 1/2" (546)	40 3/8" (1026)
	Picture	61 7/8" (1572)	74 1/8" (1883)	X	38" (965)	61 7/8" (1572)	17" (432)	35 7/8" (911)	21 1/2" (546)	40 3/8" (1026)
	Venting or Stationary	36 3/8" (924)	74 1/4" (1886)	X	26 1/8" (664)	73 7/8" (1876)	17" (432)	35 7/8" (911)	21 1/2" (546)	40 3/8" (1026)
	Venting or Stationary	53 1/2" (1359)	110 3/8" (2804)	X	26 1/8" (664)	73 7/8" (1876)	17" (432)	35 7/8" (911)	21 1/2" (546)	40 3/8" (1026)

**Custom Casement 10° Bow Window Size and Projection Range**

Window Configuration	Center Window Venting Configuration	Bow Window Dimension				Projection		
		Minimum Width Inches/(mm)	Maximum Width Inches/(mm)	Minimum Height Inches/(mm)	Maximum Height Inches/(mm)	Minimum Depth Inches/(mm)	Maximum Depth Inches/(mm)	
<b>3-Wide</b>	Venting or Stationary	52 1/2" (1334)	108 7/8" (2765)	X	26 1/8" (664)	73 7/8" (1876)	4 3/8" (111)	7 5/8" (194)
<b>4-Wide</b>	Venting or Stationary	69 1/2" (1765)	143 7/8" (3654)	X	26 1/8" (664)	73 7/8" (1876)	7 3/8" (187)	13 7/8" (352)
<b>5-Wide</b>	Venting or Stationary	85 7/8" (2181)	164 1/4" (4172)	X	26 1/8" (664)	73 7/8" (1876)	10 3/8" (264)	18 5/8" (473)
<b>6-Wide</b>	Venting or Stationary	101 5/8" (2581)	164 1/4" (4172)	X	26 1/8" (664)	73 7/8" (1876)	14 7/8" (378)	23 3/16" (589)
<b>7-Wide</b>	Venting or Stationary	116 5/8" (2962)	164 1/4" (4172)	X	26 1/8" (664)	73 7/8" (1876)	19 3/16" (487)	26 3/8" (670)

**⚠ WARNING**

Proper support of projecting bow and bay windows is required, see installation instructions. Failure to do so may result in injury, product or property damage.

- "Projection" refers to outside of the exterior sheathing to the outer edge of the window.
- "Window Dimension" always refers to outside frame to frame dimension.
- **"Minimum Rough Opening" dimensions may need to be increased to allow for use of building wraps, flashing, sill panning, brackets, fasteners or other items. See pages 210-211 for more details.**
- One Andersen cable kit, with two cables, is included with the unit for proper installation. Each cable supports a maximum load of 500 lbs/227 kg; additional support is necessary for loads exceeding 1000 lbs/454 kg.
- Angle bay and bow windows include only the basic unit. Roof and other installation materials provided by other manufacturers.
- For walkout angle bay and bow window details and installation guidelines, contact your Andersen supplier.
- Refer to [andersenwindows.com/measure](http://andersenwindows.com/measure) for detailed instructions on how to properly measure for custom-size windows.
- Dimensions in parentheses are in millimeters.

# BAY & BOW WINDOWS

**Table of Double-Hung 30° Angle Bay Window Sizes with Picture Window and 1-8 Flanking Windows**

		Projection 12 3/4" (324)					
<b>WIDTHS</b>							
Bay Window Dimension		6'-8 15/16" (2056)	7'-0 15/16" (2157)	7'-6 5/8" (2302)	7'-10 5/8" (2403)	8'-6 5/8" (2607)	9'-2 5/8" (2810)
<b>Minimum Rough Opening</b>		6'-8 1/8" (2035)	7'-0 1/8" (2137)	7'-5 3/4" (2280)	7'-9 3/4" (2381)	8'-5 3/4" (2584)	9'-1 3/4" (2788)
<b>HEIGHTS</b>							
4'-2 1/4" (1276)		30-30310-18		30-310310-18	30-42310-18	30-410310-18	
4'-2 3/4" (1289)							
4'-6 1/4" (1378)		30-3042-18	30-3442-18	30-31042-18	30-4242-18	30-41042-18	30-5642-18
4'-6 3/4" (1391)							
4'-10 1/4" (1480)		30-3046-18	30-3446-18	30-31046-18	30-4246-18	30-41046-18	30-5646-18
4'-10 3/4" (1492)							
5'-6 1/4" (1683)		30-3052-18		30-31052-18	30-4252-18	30-41052-18	
5'-6 3/4" (1695)							
5'-10 1/4" (1784)				30-31056-18	30-4256-18		
5'-10 3/4" (1797)							
6'-6 1/4" (1988)				30-31062-18	30-4262-18		
6'-6 3/4" (2000)							

**Table of Double-Hung 30° Angle Bay Window Sizes with Picture Window and 2-0 Flanking Windows**

		Projection 14 3/4" (375)					
<b>WIDTHS</b>							
Bay Window Dimension		7'-3 7/8" (2232)	7'-7 7/8" (2334)	8'-1 9/16" (2478)	8'-5 9/16" (2580)	9'-1 9/16" (2783)	9'-9 9/16" (2986)
<b>Minimum Rough Opening</b>		7'-3" (2210)	7'-7" (2311)	8'-0 3/4" (2457)	8'-4 3/4" (2559)	9'-0 3/4" (2762)	9'-8 3/4" (2965)
<b>HEIGHTS</b>							
4'-2 1/4" (1276)		30-30310-20		30-310310-20	30-42310-20	30-410310-20	
4'-2 3/4" (1289)							
4'-6 1/4" (1378)		30-3042-20	30-3442-20	30-31042-20	30-4242-20	30-41042-20	30-5642-20
4'-6 3/4" (1391)							
4'-10 1/4" (1480)		30-3046-20	30-3446-20	30-31046-20	30-4246-20	30-41046-20	30-5646-20
4'-10 3/4" (1492)							
5'-6 1/4" (1683)		30-3052-20		30-31052-20	30-4252-20	30-41052-20	
5'-6 3/4" (1695)							
5'-10 1/4" (1784)				30-31056-20	30-4256-20		
5'-10 3/4" (1797)							
6'-6 1/4" (1988)				30-31062-20	30-4262-20		
6'-6 3/4" (2000)							

**⚠ WARNING**

Proper support of projecting bow and bay windows is required, see installation instructions. Failure to do so may result in injury, product or property damage.

**Ordering Prefix:**

- WDH** 400 Series Woodwright® Double-Hung Window
- WPW** 400 Series Woodwright Picture Window
- TW** 400 Series Tilt-Wash Double-Hung Window
- DHP** 400 Series Tilt-Wash Picture Window

- \* "Projection" refers to outside of the exterior sheathing to the outer edge of the window.
- \* "Window Dimension" always refers to outside frame to frame dimension.
- \* **"Minimum Rough Opening" dimensions may need to be increased to allow for use of building wraps, flashing, sill panning, brackets, fasteners or other items. See pages 210-211 for more details.**
- \* One Andersen cable kit, with two cables, is included with the unit for proper installation. Each cable supports a maximum load of 500 lbs/227 kg; additional support is necessary for loads exceeding 1000 lbs/454 kg.
- \* Angle bay and bow windows include only the basic unit. Roof and other installation materials provided by other manufacturers.
- \* For walkout angle bay and bow window details and installation guidelines, contact your Andersen supplier.
- \* Dimensions in parentheses are in millimeters.

**Table of Double-Hung 30° Angle Bay Window Sizes with 1-8 Flanking Double-Hung Windows**

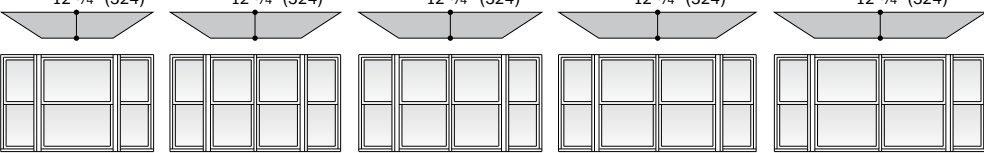
		Projection				
		12 3/4" (324)	12 3/4" (324)	12 3/4" (324)	12 3/4" (324)	12 3/4" (324)
<b>WIDTHS</b>						
	Bay Window Dimension	7'-0 15/16" (2157)	7'-10 5/8" (2403)	8'-6 5/8" (2599)	9'-2 5/8" (2810)	9'-10 5/8" (3013)
	<b>Minimum Rough Opening</b>	7'-0 1/8" (2137)	7'-9 3/4" (2581)	8'-5 3/4" (2584)	9'-1 3/4" (2788)	9'-9 3/4" (2991)
<b>HEIGHTS</b>	4'-2 1/4" (1276)	30-34310-18	30-20310-2-18	30-24310-2-18	30-28310-2-18	30-30310-2-18
	4'-2 3/4" (1289)					
	4'-6 1/4" (1378)	30-3442-18	30-2042-2-18	30-2442-2-18	30-2842-2-18	30-3042-2-18
	4'-6 3/4" (1391)					
	4'-10 1/4" (1480)	30-3446-18	30-2046-2-18	30-2446-2-18	30-2846-2-18	30-3046-2-18
	4'-10 3/4" (1492)					
	5'-6 1/4" (1683)	30-3452-18	30-2052-2-18	30-2452-2-18	30-2852-2-18	30-3052-2-18
	5'-6 3/4" (1695)					
	5'-10 1/4" (1784)	30-3456-18	30-2056-2-18	30-2456-2-18	30-2856-2-18	30-3056-2-18
	5'-10 3/4" (1797)					
	6'-6 1/4" (1988)	30-3462-18	30-2062-2-18	30-2462-2-18	30-2862-2-18	30-3062-2-18
	6'-6 3/4" (2000)					

**Table of Double-Hung 30° Angle Bay Window Sizes with 2-0 Flanking Double-Hung Windows**

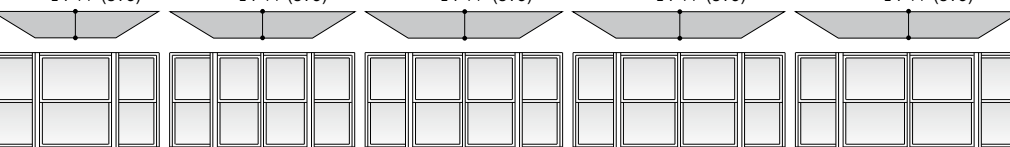
		Projection				
		14 3/4" (375)	14 3/4" (375)	14 3/4" (375)	14 3/4" (375)	14 3/4" (375)
<b>WIDTHS</b>						
	Bay Window Dimension	7'-7 7/8" (2334)	8'-5 9/16" (2580)	9'-1 9/16" (2783)	9'-9 9/16" (2986)	10'-5 9/16" (3189)
	<b>Minimum Rough Opening</b>	7'-7" (2311)	8'-4 3/4" (2559)	9'-0 3/4" (2762)	9'-8 3/4" (2965)	10'-4 3/4" (3169)
<b>HEIGHTS</b>	4'-2 1/4" (1276)	30-34310-20	30-20310-2-20	30-24310-2-20	30-28310-2-20	30-30310-2-20
	4'-2 3/4" (1289)					
	4'-6 1/4" (1378)	30-3442-20	30-2042-2-20	30-2442-2-20	30-2842-2-20	30-3042-2-20
	4'-6 3/4" (1391)					
	4'-10 1/4" (1480)	30-3446-20	30-2046-2-20	30-2446-2-20	30-2846-2-20	30-3046-2-20
	4'-10 3/4" (1492)					
	5'-6 1/4" (1683)	30-3452-20	30-2052-2-20	30-2452-2-20	30-2852-2-20	30-3052-2-20
	5'-6 3/4" (1695)					
	5'-10 1/4" (1784)	30-3456-20	30-2056-2-20	30-2456-2-20	30-2856-2-20	30-3056-2-20
	5'-10 3/4" (1797)					
	6'-6 1/4" (1988)	30-3462-20	30-2062-2-20	30-2462-2-20	30-2862-2-20	30-3062-2-20
	6'-6 3/4" (2000)					

**⚠ WARNING**

Proper support of projecting bow and bay windows is required, see installation instructions. Failure to do so may result in injury, product or property damage.

**Ordering Prefix:**

- WDH** 400 Series Woodwright® Double-Hung Window
- WPW** 400 Series Woodwright Picture Window
- TW** 400 Series Tilt-Wash Double-Hung Window
- DHP** 400 Series Tilt-Wash Picture Window

- \*"Projection" refers to outside of the exterior sheathing to the outer edge of the window.
- \*"Window Dimension" always refers to outside frame to frame dimension.
- \*"Minimum Rough Opening" dimensions may need to be increased to allow for use of building wraps, flashing, sill panning, brackets, fasteners or other items. See pages 210-211 for more details.
- \*One Andersen cable kit, with two cables, is included with the unit for proper installation. Each cable supports a maximum load of 500 lbs/227 kg; additional support is necessary for loads exceeding 1000 lbs/454 kg.
- \*Angle bay and bow windows include only the basic unit. Roof and other installation materials provided by other manufacturers.
- \*For walkout angle bay and bow window details and installation guidelines, contact your Andersen supplier.
- \*Dimensions in parentheses are in millimeters.

# BAY & BOW WINDOWS

## Table of Double-Hung 45° Angle Bay Window Sizes with Picture Window and 1-8 Flanking Windows

		Projection		17 15/16" (456)		17 15/16" (456)		17 15/16" (456)		17 15/16" (456)		17 15/16" (456)		17 15/16" (456)	
<b>WIDTHS</b>															
<b>HEIGHTS</b>	Bay Window Dimension	6'-4 7/16"	6'-8 7/16"	7'-2 1/8"	7'-6 1/8"	8'-2 1/8"	8'-10 1/8"	(1942)	(2043)	(2188)	(2289)	(2492)	(2696)		
	Minimum Rough Opening	6'-3 1/8"	6'-7 1/8"	7'-0 3/4"	7'-4 3/4"	8'-0 3/4"	8'-8 3/4"	(1908)	(2010)	(2153)	(2254)	(2457)	(2661)		
	4'-2 1/4" (1276)	45-30310-18		45-310310-18	45-42310-18	45-410310-18									
	4'-2 3/4" (1289)														
	4'-6 1/4" (1378)	45-3042-18	45-3442-18	45-31042-18	45-4242-18	45-41042-18	45-5642-18								
	4'-6 3/4" (1391)														
	4'-10 1/4" (1480)	45-3046-18	45-3446-18	45-31046-18	45-4246-18	45-41046-18	45-5646-18								
	4'-10 3/4" (1492)														
	5'-6 1/4" (1683)	45-3052-18		45-31052-18	45-4252-18	45-41052-18									
	5'-6 3/4" (1695)														
	5'-10 1/4" (1784)			45-31056-18	45-4256-18										
	5'-10 3/4" (1797)														
	6'-6 1/4" (1988)			45-31062-18	45-4262-18										
	6'-6 3/4" (2000)														

## Table of Double-Hung 45° Angle Bay Window Sizes with Picture Window and 2-0 Flanking Windows

		Projection		20 3/4" (527)		20 3/4" (527)		20 3/4" (527)		20 3/4" (527)		20 3/4" (527)		20 3/4" (527)	
<b>WIDTHS</b>															
<b>HEIGHTS</b>	Bay Window Dimension	6'-10 1/8"	7'-2 1/8"	7'-7 13/16"	7'-11 13/16"	8'-7 13/16"	9'-3 13/16"	(2086)	(2188)	(2332)	(2434)	(2637)	(2840)		
	Minimum Rough Opening	6'-8 3/4"	7'-0 3/4"	7'-6 1/2"	7'-10 1/2"	8'-6 1/2"	9'-2 1/2"	(2051)	(2153)	(2299)	(2400)	(2604)	(2807)		
	4'-2 1/4" (1276)	45-30310-20		45-310310-20	45-42310-20	45-410310-20									
	4'-2 3/4" (1289)														
	4'-6 1/4" (1378)	45-3042-20	45-3442-20	45-31042-20	45-4242-20	45-41042-20	45-5642-20								
	4'-6 3/4" (1391)														
	4'-10 1/4" (1480)	45-3046-20	45-3446-20	45-31046-20	45-4246-20	45-41046-20	45-5646-20								
	4'-10 3/4" (1492)														
	5'-6 1/4" (1683)	45-3052-20		45-31052-20	45-4252-20	45-41052-20									
	5'-6 3/4" (1695)														
	5'-10 1/4" (1784)			45-31056-20	45-4256-20										
	5'-10 3/4" (1797)														
	6'-6 1/4" (1988)			45-31062-20	45-4262-20										
	6'-6 3/4" (2000)														

### ⚠ WARNING

Proper support of projecting bow and bay windows is required, see installation instructions. Failure to do so may result in injury, product or property damage.

- WDH** 400 Series Woodwright® Double-Hung Window
- WPW** 400 Series Woodwright Picture Window
- TW** 400 Series Tilt-Wash Double-Hung Window
- DHP** 400 Series Tilt-Wash Picture Window

- \* "Projection" refers to outside of the exterior sheathing to the outer edge of the window.
- \* "Window Dimension" always refers to outside frame to frame dimension.
- \* **"Minimum Rough Opening" dimensions may need to be increased to allow for use of building wraps, flashing, sill panning, brackets, fasteners or other items. See pages 210-211 for more details.**
- \* One Andersen cable kit, with two cables, is included with the unit for proper installation. Each cable supports a maximum load of 500 lbs/227 kg; additional support is necessary for loads exceeding 1000 lbs/454 kg.
- \* Angle bay and bow windows include only the basic unit. Roof and other installation materials provided by other manufacturers.
- \* For walkout angle bay and bow window details and installation guidelines, contact your Andersen supplier.
- \* Dimensions in parentheses are in millimeters.

**Table of Double-Hung 45° Angle Bay Window Sizes with 1-8 Flanking Windows**

		Projection				
		17 15/16" (456)	17 15/16" (456)	17 15/16" (465)	17 15/16" (456)	17 15/16" (456)
<b>WIDTHS</b>						
	Bay Window Dimension	6'-8 7/16" (2043)	7'-6 1/8" (2289)	8'-2 1/8" (2492)	8'-10 1/8" (2696)	9'-6 1/8" (2899)
	<b>Minimum Rough Opening</b>	6'-7 1/8" (2010)	7'-4 7/8" (2257)	8'-0 3/4" (2445)	8'-8 3/4" (2661)	9'-4 3/4" (2864)
<b>HEIGHTS</b>	4'-2 1/4" (1276)	45-34310-18	45-20310-2-18	45-24310-2-18	45-28310-2-18	45-30310-2-18
	4'-2 3/4" (1289)					
	4'-6 1/4" (1378)	45-3442-18	45-2042-2-18	45-2442-2-18	45-2842-2-18	45-3042-2-18
	4'-6 3/4" (1391)					
	4'-10 1/4" (1480)	45-3446-18	45-2046-2-18	45-2446-2-18	45-2846-2-18	45-3046-2-18
	4'-10 3/4" (1492)					
	5'-6 1/4" (1683)	45-3452-18	45-2052-2-18	45-2452-2-18	45-2852-2-18	45-3052-2-18
	5'-6 3/4" (1695)					
	5'-10 1/4" (1784)	45-3456-18	45-2056-2-18	45-2456-2-18	45-2856-2-18	45-3056-2-18
	5'-10 3/4" (1797)					
	6'-6 1/4" (1988)	45-3462-18	45-2062-2-18	45-2462-2-18	45-2862-2-18	45-3062-2-18
	6'-6 3/4" (2000)					

**Table of Double-Hung 45° Angle Bay Window Sizes with 2-0 Flanking Windows**

		Projection				
		20 3/4" (257)	20 3/4" (257)	20 3/4" (257)	20 3/4" (257)	20 3/4" (257)
<b>WIDTHS</b>						
	Bay Window Dimension	7'-2 1/8" (2188)	7'-11 13/16" (2434)	8'-7 13/16" (2637)	9'-3 13/16" (2840)	9'-11 13/16" (3043)
	<b>Minimum Rough Opening</b>	7'-0 3/4" (2153)	7'-10 1/2" (2400)	8'-6 1/2" (2604)	9'-2 1/2" (2807)	9'-10 1/2" (3010)
<b>HEIGHTS</b>	4'-2 1/4" (1276)	45-34310-20	45-20310-2-20	45-24310-2-20	45-28310-2-20	45-30310-2-20
	4'-2 3/4" (1289)					
	4'-6 1/4" (1378)	45-3442-20	45-2042-2-20	45-2442-2-20	45-2842-2-20	45-3042-2-20
	4'-6 3/4" (1391)					
	4'-10 1/4" (1480)	45-3446-20	45-2046-2-20	45-2446-2-20	45-2846-2-20	45-3046-2-20
	4'-10 3/4" (1492)					
	5'-6 1/4" (1683)	45-3452-20	45-2052-2-20	45-2452-2-20	45-2852-2-20	45-3052-2-20
	5'-6 3/4" (1695)					
	5'-10 1/4" (1784)	45-3456-20	45-2056-2-20	45-2456-2-20	45-2856-2-20	45-3056-2-20
	5'-10 3/4" (1797)					
	6'-6 1/4" (1988)	45-3462-20	45-2062-2-20	45-2462-2-20	45-2862-2-20	45-3062-2-20
	6'-6 3/4" (2000)					

**⚠ WARNING**

Proper support of projecting bow and bay windows is required, see installation instructions. Failure to do so may result in injury, product or property damage.

**Ordering Prefix:**

- WDH** 400 Series Woodwright® Double-Hung Window
- WPW** 400 Series Woodwright Picture Window
- TW** 400 Series Tilt-Wash Double-Hung Window
- DHP** 400 Series Tilt-Wash Picture Window

- \*"Projection" refers to outside of the exterior sheathing to the outer edge of the window.
- \*"Window Dimension" always refers to outside frame to frame dimension.
- \*"Minimum Rough Opening" dimensions may need to be increased to allow for use of building wraps, flashing, sill panning, brackets, fasteners or other items. See pages 210-211 for more details.
- \*One Andersen cable kit, with two cables, is included with the unit for proper installation. Each cable supports a maximum load of 500 lbs/227 kg; additional support is necessary for loads exceeding 1000 lbs/454 kg.
- \*Angle bay and bow windows include only the basic unit. Roof and other installation materials provided by other manufacturers.
- \*For walkout angle bay and bow window details and installation guidelines, contact your Andersen supplier.
- \*Dimensions in parentheses are in millimeters.

# BAY & BOW WINDOWS

## Double-Hung 30° Angle Bay Window Details

Scale 1 1/2" (38) = 1'-0" (305) – 1:8

Woodwright® double-hung 30° angle bay window shown. Tilt-wash double-hung 30° angle bay window installation is similar.

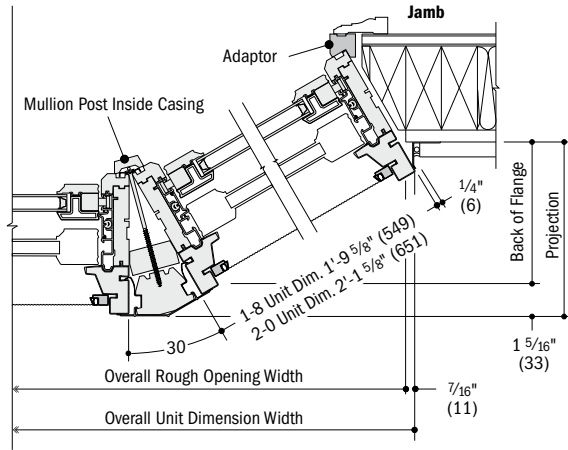

Horizontal Section

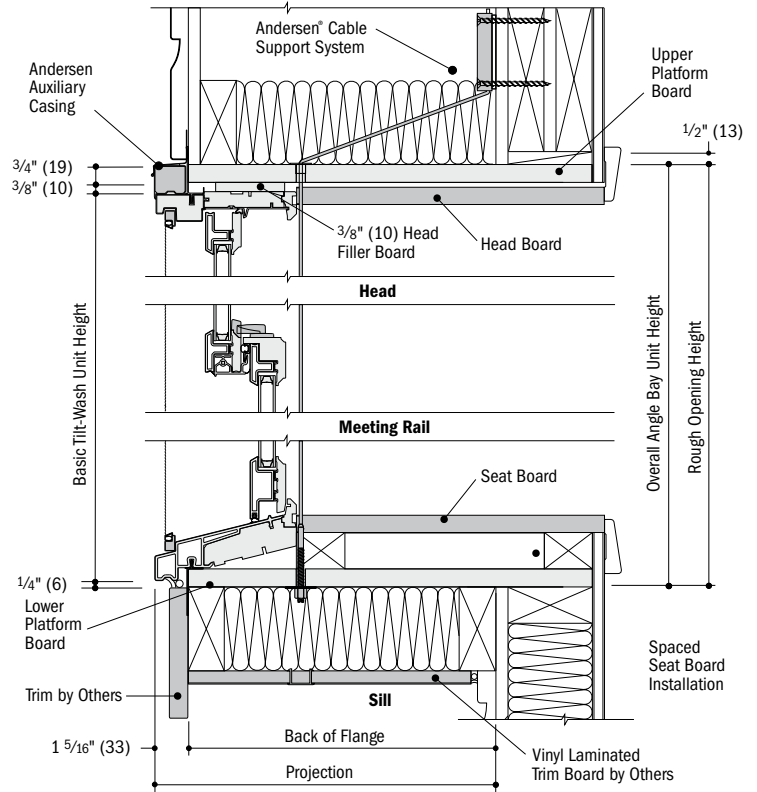

Vertical Section

## Double-Hung 45° Angle Bay Window Details

Scale 1 1/2" (38) = 1'-0" (305) – 1:8

Tilt-wash double-hung 30° angle bay window shown. Woodwright® double-hung 30° angle bay window installation is similar.

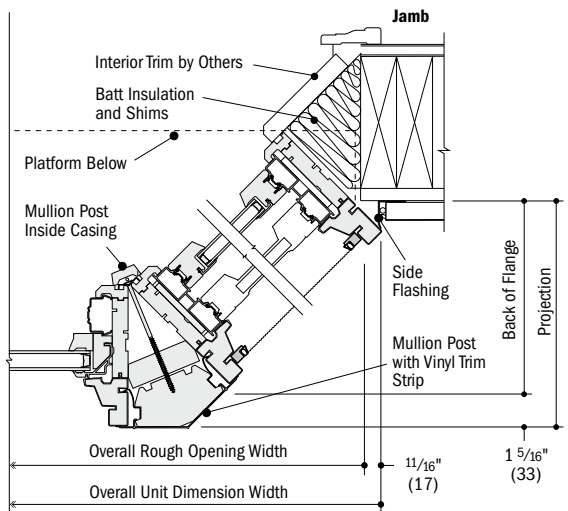

Horizontal Section

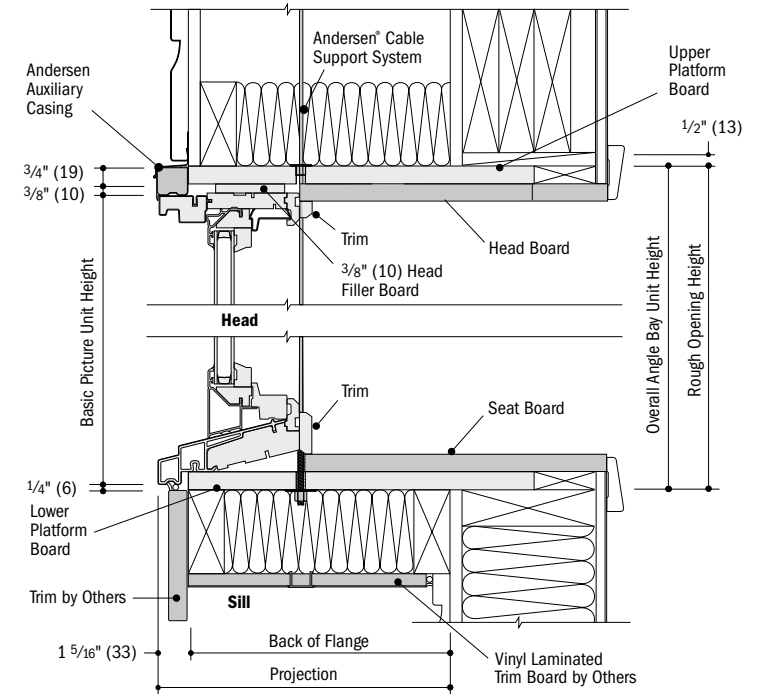

Vertical Section

\* Light-colored areas are parts included with window. Dark-colored areas are additional Andersen® parts required to complete window assembly as shown.  
 \* **Rough openings may need to be increased to allow for use of building wraps, flashing, sill panning, brackets, fasteners or other items. See installation information on pages 210-211.**  
 \* Details are for illustration only and are not intended to represent product installation methods or materials. Refer to unit installation guides at andersenwindows.com.  
 \* Dimensions in parentheses are in millimeters.

# GLIDING WINDOWS

400 Series  
Gliding Windows



## SECTION REFERENCE

Table of Sizes.....	114
Specifications .....	115
Grille Patterns .....	115
Window Details .....	116
Product Performance.....	194

Dimensions in parentheses are in millimeters.

# GLIDING WINDOWS

## FEATURES

### Frame

- A** The exterior of the frame is covered with fiberglass to maintain an attractive appearance while minimizing maintenance.
- B** Wood frame members are treated with a water-repellent wood preservative for long-lasting\* protection and performance.
- C** Flexible bulb weatherstrip and spring tension vinyl are installed at the factory and help provide a tight seal between the sash and frame.
- D** Fold-out-and-lock installation flanges accommodate 4 1/2" (114) and 4 1/8" (105) wall construction.

### Sash

- E** For improved ventilation, both sash are operable. Rigid vinyl encases the entire sash. A vinyl weld protects each sash corner for superior weathertightness to maintain an attractive appearance and minimize maintenance.
- F** Natural wood sash members help provide excellent structural stability and energy efficiency.
- G** Interior stops are unfinished pine. Low-maintenance prefinished white, Sandtone, dark bronze and black\*\* interiors are also available.

### Delrin® Glides



Teflon® infused Delrin glides are self-lubricating and require only 8 lbs/3.6 kg of force to operate. A stainless steel spring within the glide provides years\* of reliable operation — even in harsh environments.

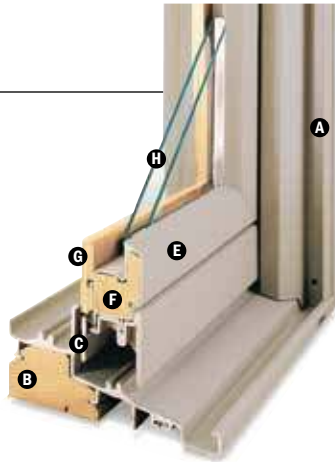

### Glass

**H** High-Performance glass options include:

- Low-E4® glass
- Low-E4 HeatLock® glass
- Low-E4 Sun glass
- Low-E4 SmartSun™ glass
- Low-E4 SmartSun HeatLock glass

Tempered glass and other glass options are available. Contact your Andersen supplier.

A removable translucent film helps shield the glass from damage during delivery and construction and simplifies finishing at the jobsite.

### Patterned Glass

Patterned glass options are available. See page 12 for more details.

### Hardware

#### Locking System

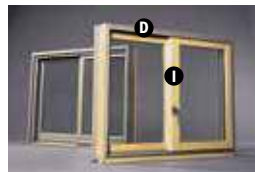

**1** For an added measure of security and increased weathertightness, the locking system pulls the sash firmly closed while pushing the sash tight to the side jambs. This lock is single-point on 2' (610) tall windows, two-point on 3' (914) tall windows, and three-point on 3'-6" (1067), 4' (1219) and 5' (1524) tall windows.

## EXTERIOR



## INTERIOR



Naturally occurring variations in grain, color and texture of wood make each window one of a kind. All wood interiors are unfinished unless a prefinished option is specified.

## HARDWARE FINISHES



Distressed bronze and oil rubbed bronze are "living" finishes that will change with time and use.

## GLIDING WINDOW HARDWARE‡

### ROTATING SASH HANDLE

Antique Brass | Black | Bright Brass  
Brushed Chrome | Distressed Bronze  
Distressed Nickel | Oil Rubbed Bronze  
Polished Chrome | **Satin Nickel**  
Stone | White

Bold name denotes finish shown.



\* Visit [andersenwindows.com/warranty](http://andersenwindows.com/warranty) for details.

\*\* Sandtone interior available with Sandtone, canvas, Terratone, dark bronze and black exteriors.

† White, dark bronze and black interiors are only available with white, dark bronze and black exteriors respectively.

‡ Hardware sold separately.

Dimensions in parentheses are in millimeters.

\*Delrin® and Teflon® are registered trademarks of E.I. du Pont de Nemours and Company.

Printing limitations prevent exact replication of colors and finishes. See your Andersen supplier for actual color and finish samples.

**ACCESSORIES** Sold Separately

**Frame**

**Extension Jamb**



Standard jamb depth is 4 9/16" (116). Extension jambs are available in unfinished pine or prefinished white, dark bronze or black. Some sizes may be veneered.

Factory-applied and non-applied interior extension jambs are available in 1/16" (1.5) increments between 5 1/16" (129) and 7 1/8" (181).

**Hardware**

**Passive Sash Handle**



Attaches to the passive sash to aid in operation. Available in Sandtone.

**Window Opening Control Device Kit**



A Window Opening Control Device Kit is available, which limits sash travel to less than 4" (102) when the window is first opened. Available in stone, white and black. Device shown on a 200 Series gliding window.

**Insect Screens**

Choose a fixed, full insect screen or gliding pass-through insect screen. Frames are available in colors to match product exteriors.

**TruScene® Insect Screen**

Exclusive Andersen® TruScene insect screens provide over 50% more clarity than our conventional insect screens for a beautiful unobstructed view. They allow more fresh air and sunlight in, while doing a better job of keeping out small insects.

**Conventional Insect Screen**

Conventional insect screens have charcoal powder-coated aluminum screen mesh.

**Grilles**

Grilles are available in a variety of configurations and widths. For gliding window grille patterns, see page 115.

**Exterior Trim**

This product is available with Andersen exterior trim. See pages 175-180 for details.

**CAUTION:**

- Painting and staining may cause damage to rigid vinyl.
- Do not paint 400 Series windows with white, canvas, Sandtone, forest green, dark bronze or black exterior colors.
- Andersen does not warrant the adhesion or performance of homeowner-applied paint over vinyl or other factory-coated surfaces.
- 400 Series windows in Terratone color may be painted any color lighter than Terratone color using quality oil-based or latex paint.
- For vinyl painting instructions and preparation, contact your Andersen supplier.
- Do not paint weatherstrip.
- Creosote-based stains should not come in contact with Andersen products.
- Abrasive cleaners or solutions containing corrosive solvents should not be used on Andersen products.

400 Series  
 Gliding Windows

For more information about **glass, patterned glass, grilles and TruScene insect screens**, see pages 12-14.

For more information about **product performance, installation instructions and accessories**, see pages 194-211 or visit [andersenwindows.com](http://andersenwindows.com).

Dimensions in parentheses are in millimeters.

# GLIDING WINDOWS

## Table of Gliding Window Sizes

Scale 1/8" (3) = 1'-0" (305) – 1:96

Window Dimension	2'-11 1/4" (895)	3'-11 1/4" (1200)	4'-11 1/4" (1505)	5'-11 1/4" (1810)
<b>Minimum Rough Opening</b>	3'-0" (914)	4'-0" (1219)	5'-0" (1524)	6'-0" (1829)
Unobstructed Glass (single sash only)	12 9/16" (319)	18 9/16" (472)	24 9/16" (624)	30 9/16" (776)

1'-10 1/4" (565)	1'-11" (584)	14-1/8" (359)		
<b>G32</b>	<b>G42</b>			
2'-11 1/4" (895)	3'-0" (914)	27 1/8" (689)		
<b>G33</b>	<b>G43</b>			
3'-5 1/4" (1048)	3'-6" (1067)	33 1/8" (841)		
<b>G336</b>	<b>G436</b>			
3'-11 1/4" (1200)	4'-0" (1219)	39 1/8" (994)		
<b>G34</b>	<b>G44°</b>			
4'-11 1/4" (1505)	5'-0" (1524)	51 1/8" (1299)		
<b>G35</b>	<b>G45°</b>			

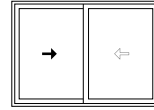

Active Passive

Viewed from the exterior. Passive sash will open after active sash has been opened.

Grille patterns shown on page 115.

- \* "Window Dimension" always refers to outside frame to frame dimension.
- \* "Minimum Rough Opening" dimensions may need to be increased to allow for use of building wraps, flashing, sill panning, brackets, fasteners or other items. See pages 210-211 for more details.
- \* Dimensions in parentheses are in millimeters.
- ° Meet or exceed clear opening area of 5.7 sq. ft. or 0.53 m<sup>2</sup>, clear opening width of 20" (508) and clear opening height of 24" (610). See table on page 115.

## Handle Location

Operational force of handle is equal to 8 lbs/3.6 kg.

Dimensions shown are from top of handle in open position.

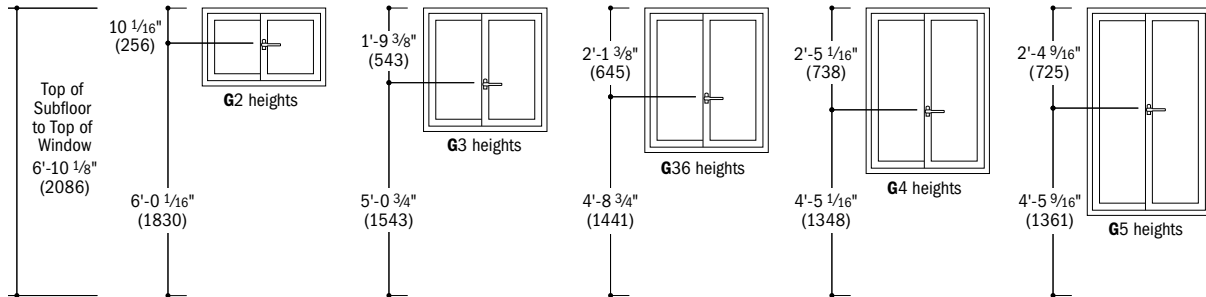

\* Dimensions in parentheses are in millimeters.



**Gliding Window Opening and Area Specifications**

Window Number	Clear Opening Area Sq. Ft./ (m <sup>2</sup> )	Clear Opening in Full Open Position		Glass Area Sq. Ft./ (m <sup>2</sup> )	Vent Area Sq. Ft./ (m <sup>2</sup> )	Top of Subfloor to Top of Sill Parting Stop Inches/ (mm)	Overall Window Area Sq. Ft./ (m <sup>2</sup> )
		Width Inches/ (mm)	Height Inches/ (mm)				
G32	1.70 (0.16)	14 9/32" (363)	17 1/8" (435)	2.5 (0.23)	1.70 (0.16)	62 9/16" (1589)	5.45 (0.51)
G33	3.00 (0.28)	14 9/32" (363)	30 1/8" (765)	4.7 (0.44)	3.00 (0.28)	49 9/16" (1259)	8.63 (0.80)
G336	3.58 (0.33)	14 9/32" (363)	36 1/8" (918)	5.7 (0.53)	3.58 (0.33)	43 9/16" (1107)	10.10 (0.94)
G34	4.18 (0.39)	14 9/32" (363)	42 1/8" (1070)	6.8 (0.63)	4.18 (0.39)	37 9/16" (954)	11.57 (1.08)
G35	5.40 (0.50)	14 9/32" (363)	54 1/8" (1375)	8.9 (0.83)	5.40 (0.50)	25 9/16" (649)	14.50 (1.35)
G42	2.40 (0.22)	20 9/32" (515)	17 1/8" (435)	3.6 (0.33)	2.40 (0.22)	62 9/16" (1589)	7.30 (0.68)
G43	4.40 (0.41)	20 9/32" (515)	30 1/8" (765)	7.0 (0.65)	4.40 (0.41)	49 9/16" (1259)	11.57 (1.08)
G436	5.10 (0.47)	20 9/32" (515)	36 1/8" (918)	8.5 (0.79)	5.10 (0.47)	43 9/16" (1107)	13.54 (1.26)
G44 ◊	6.00 (0.56)	20 9/32" (515)	42 1/8" (1070)	10.0 (0.93)	6.00 (0.56)	37 9/16" (954)	15.50 (1.44)
G45 ◊	7.62 (0.71)	20 9/32" (515)	54 1/8" (1375)	13.1 (1.22)	7.62 (0.71)	25 9/16" (649)	19.44 (1.81)
G53	5.50 (0.51)	26 9/32" (668)	30 1/8" (765)	9.2 (0.86)	5.50 (0.51)	49 9/16" (1259)	14.50 (1.35)
G536 ◊	6.60 (0.61)	26 9/32" (668)	36 1/8" (918)	11.3 (1.05)	6.60 (0.61)	43 9/16" (1107)	16.97 (1.58)
G54 ◊	7.70 (0.72)	26 9/32" (668)	42 1/8" (1070)	13.3 (1.24)	7.70 (0.72)	37 9/16" (954)	19.44 (1.81)
G55 ◊	9.90 (0.92)	26 9/32" (668)	54 1/8" (1375)	17.4 (1.62)	9.90 (0.92)	25 9/16" (649)	24.38 (2.27)
G63 ◊	6.75 (0.63)	32 9/32" (820)	30 1/8" (765)	11.5 (1.07)	6.75 (0.63)	49 9/16" (1259)	17.44 (1.62)
G636 ◊	8.10 (0.75)	32 9/32" (820)	36 1/8" (918)	14.0 (1.30)	8.10 (0.75)	43 9/16" (1107)	20.41 (1.90)
G64 ◊	9.44 (0.88)	32 9/32" (820)	42 1/8" (1070)	16.6 (1.54)	9.44 (0.88)	37 9/16" (954)	23.38 (2.17)
G65 ◊	12.13 (1.13)	32 9/32" (820)	54 1/8" (1375)	21.7 (2.02)	12.13 (1.13)	25 9/16" (649)	29.32 (2.72)

\*Top of Subfloor to Top of Inside Sill Stop" is calculated based upon a structural header height of 6'-10 1/2" (2096).  
 \*Dimensions in parentheses are in millimeters or square meters.  
 ◊ Meet or exceed clear opening area of 5.7 sq. ft. or 0.53 m<sup>2</sup>, clear opening width of 20" (508) and clear opening height of 24" (610).

400 Series  
Gliding Windows

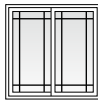
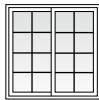
**Grille Patterns**

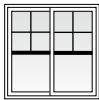
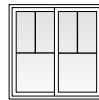
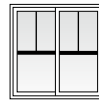
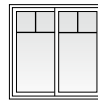
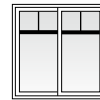
	Prairie A	Colonial	Modified Colonial	Modified Colonial with Simulated Meeting Rail	Tall Fractional	Tall Fractional with Simulated Meeting Rail	Short Fractional	Short Fractional with Simulated Meeting Rail
<b>Gliding</b>								

**Number of lights and overall pattern varies with window size. Patterns are not available in all configurations.**

Specified equal light and custom patterns are also available. For more grille options, see page 13 or visit [andersenwindows.com/grilles](http://andersenwindows.com/grilles).

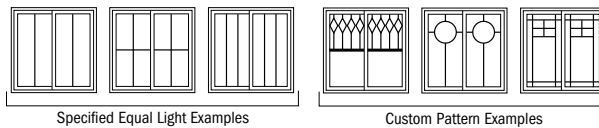

# GLIDING WINDOWS

## Gliding Window Details

Scale 1 1/2" (38) = 1'-0" (305) – 1:8

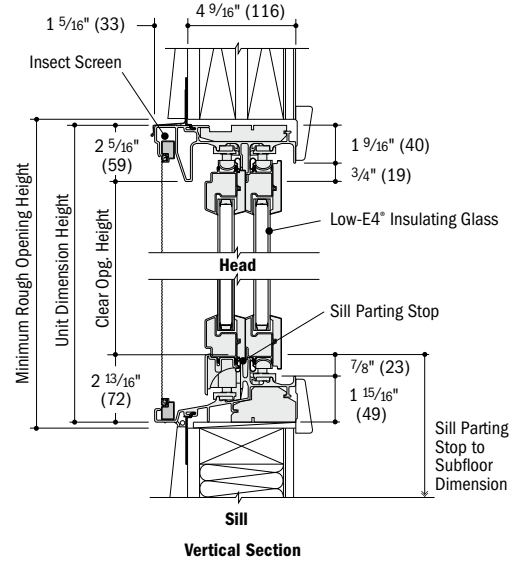
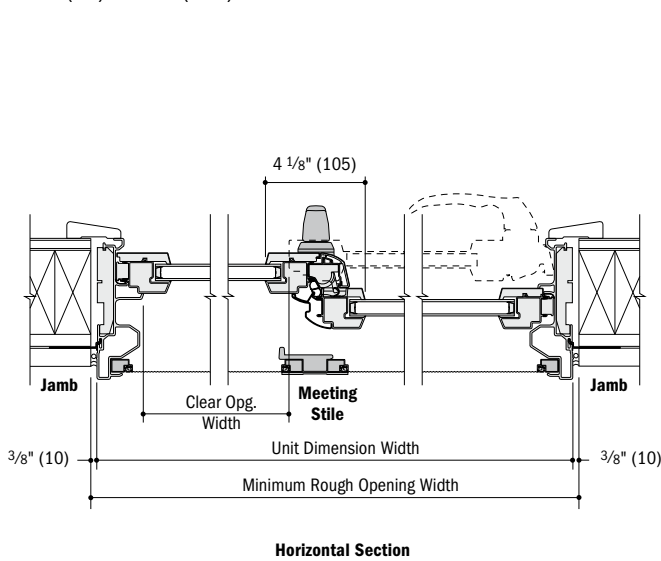

## Separate Rough Openings Detail

Scale 1 1/2" (38) = 1'-0" (305) – 1:8

To meet structural requirements or to achieve a wider joined appearance, windows may be installed into separate rough openings having vertical support (by others) in combination with Andersen® exterior filler and exterior vinyl trim.

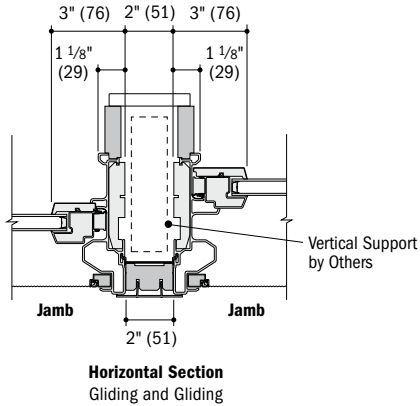

- Light-colored areas are parts included with window. Dark-colored areas are additional Andersen® parts required to complete window assembly as shown.
- **Rough openings may need to be increased to allow for use of building wraps, flashing, sill panning, brackets, fasteners or other items. See installation information on pages 210-211.**
- Details are for illustration only and are not intended to represent product installation methods or materials. Refer to product installation guides at andersenwindows.com.
- Consult with an architect or structural engineer regarding minimum requirements for structural support members between adjacent rough openings.
- Dimensions in parentheses are in millimeters.

# SPECIALTY WINDOWS

## SECTION REFERENCE

### Half Circle, Quarter Circle, Elliptical, Eyebrow, Circle, Oval, Gothic, Octagon and Monumental Circle & Quarter Circle Windows

- Tables of Sizes ..... 120-123
- Specifications ..... 121-122
- Grille Patterns ..... 122
- Window Details ..... 124-125
- Joining Details..... 126

### Custom Arch Windows..... 127

### Arch, Springline™ & Springline Flanker Windows

- Tables of Sizes ..... 128-133
- Specifications ..... 129-131
- Grille Patterns ..... 132
- Window Details ..... 133

### Flexiframe® Windows

- Shapes & Sizes ..... 134
- Window Details ..... 135
- Joining Details..... 136
- Combination Designs ..... 181
- Product Performance..... 194

### CUSTOM SIZING

in 1/8" (3) increments



Dimensions in parentheses are in millimeters.



# SPECIALTY WINDOWS

## FEATURES

### Frame

**A** Wood frame members are treated with a water-repellent preservative for long-lasting\* protection and performance. Radii are made of laminated pine, offering improved strength and appearance.

**B** The lineal sections of the jamb and sill on eyebrow, gothic, octagon, monumental, Flexiframe®, custom arch and arch windows are covered with a low-maintenance, fiberglass-reinforced composite. The arched head members and Springline™ units are covered with stretch-formed aluminum.

**C** The vinyl installation flange on eyebrow, gothic, octagon, monumental, Flexiframe, custom arch, arch and Springline units extends 1 1/4" (32) around the entire perimeter of the unit. It helps seal the unit to the structure.

**D** Circle, half circle, quarter circle, elliptical and oval windows are covered with a rigid vinyl cladding. Low-maintenance exterior cladding provides long-lasting\* beauty.

**E** Rigid vinyl cladding on circle, half circle, quarter circle, elliptical and oval window frames forms a full-perimeter installation flange for securing the unit to the structure. It also helps maintain an attractive appearance while minimizing maintenance.

**F** Inside trim stop is made of unfinished pine. Arched trim stops are made with quality, full-length laminated pine. Units are shipped with the trim stops tacked on, so removal is easy — expediting finishing and joining procedures.

**G** Unfinished interior wood glazing stops help secure the glass in place. Arched glazing stops are made with full-length laminated pine.

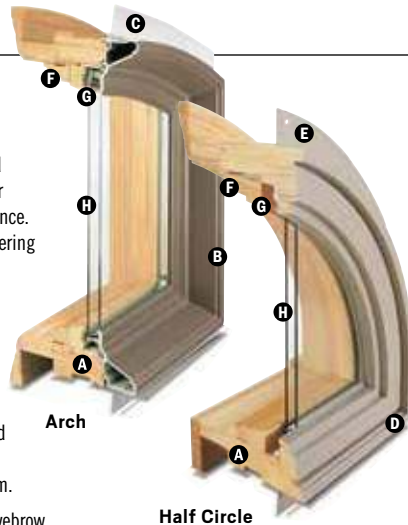

Circle/Oval



Springline™



Flexiframe®

### Glass

**H** High-Performance glass options include:

- Low-E4® glass
- Low-E4 HeatLock® glass
- Low-E4 Sun glass
- Low-E4 SmartSun™ glass
- Low-E4 SmartSun HeatLock glass

Tempered glass and other glass options are available. Contact your Andersen supplier.

A removable translucent film helps shield the glass from damage during delivery and construction and simplifies finishing at the jobsite.

### Patterned Glass

Patterned glass options are available. See page 12 for more details.



Specialty windows are available with Stormwatch® Protection. Visit [andersenwindows.com/coastal](http://andersenwindows.com/coastal) for more details.

## EXTERIOR

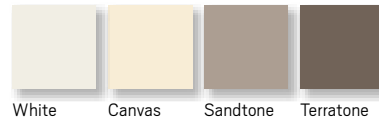

White Canvas Sandtone Terratone



Forest Green Dark Bronze Black

## INTERIOR



Pine White



Dark Bronze\*\* Black\*\*

Naturally occurring variations in grain, color and texture of wood make each window one of a kind. All wood interiors are unfinished unless a prefinished option is specified.



\* Visit [andersenwindows.com/warranty](http://andersenwindows.com/warranty) for details.

\*\* Dark bronze and black interiors are only available with dark bronze and black exteriors respectively.

Dimensions in parentheses are in millimeters.

Printing limitations prevent exact duplication of colors. See your Andersen supplier for actual color samples.

**ACCESSORIES** Sold Separately

**Frame**

**Extension Jamb**

Specify extension jambs when ordering.

Standard unit jamb depth is 2 7/8" (73), except for elliptical and double-hung half circle units, which are 4 1/2" (114).

Pine extension jambs are available for most products in 1/16" (1.5) increments between 4 9/16" (116) and 7 1/8" (181). Elliptical and double-hung half circle extension jambs are available between 5 1/16" (129) and 7 1/8" (181). Some sizes may be pine veneer.

Springline™ window extension jambs and transition blocks are applied when ordered with the unit (key component block is also applied to units with a 48" (1219) radius).

**Extension Jamb Alignment for Joined Combinations**

When joining 400 Series arch, Springline or Flexiframe® over casement or when joining arch, Springline or Flexiframe alongside awning, use Method A or Method B for extension jamb alignment. See page 135 for details.

**Method A: Individually Framed**

Specify Andersen® auxiliary extension jambs. Available for the following wall thicknesses: 4 9/16" (116), 5 1/4" (133), 6 3/16" (167) and 7 1/8" (181).

**Method B: Perimeter Framed**

Specify 1/4" (6) filler in pine or white. Requires modification of extension jambs.

**Casing**

**Interior Arch Casing**

Available in Colonial or Ranch styles. Arch casings come with transition blocks or plinth blocks, depending on the product. For easy integration and consistency, casing dimensions are consistent with Wood Moulding and Millwork Producers Association specifications. Available in pine, oak and maple.



2 1/4" (57) Colonial style. **WM366**



2 1/2" (64) Colonial style. **WM351**



3 1/2" (89) Colonial style. **WM444**



2 1/4" (57) Ranch style. **WM324**  
2 1/2" (64) Ranch style. **WM315**

**Plinth Blocks**

For enhancing casing transitions. Decorated with a radial sunburst, or use the reverse side flush face.



For arch windows, use 2 7/8" (73) x 4" (102) size plinth block with 2 1/4" (57) and 2 1/2" (64) casing. Use 3 7/8" (98) x 5 1/4" (133) size with 3 1/2" (89) casing.



For half circle, circle, elliptical and oval windows, use 2 7/8" (73) size plinth block with 2 1/4" (57) and 2 1/2" (64) casing. Use 3 7/8" (98) size with 3 1/2" (89) casing.

**Key Block**



Excellent for creating unique trim designs or accents at arch casing transitions. A key block is an option for circle and oval windows.

**Transition Blocks**



Two transition blocks come with the interior arch casing extension jambs, providing a beautiful accent for circle and oval windows.

**Glass**

**Andersen Art Glass**

Andersen art glass panels come in a variety of original patterns. See pages 173-174 for details on Andersen art glass. Visit [andersenwindows.com/artglass](http://andersenwindows.com/artglass) for details and pattern information.

**Grilles**

Grilles are available in a variety of configurations and widths. For specialty window grille patterns, see pages 122 and 132.

**Exterior Trim**

Select specialty windows are available with Andersen exterior trim. Contact your Andersen supplier for details.

**CAUTION:**

- Painting and staining may cause damage to rigid vinyl.
- Do not paint the exteriors 400 Series windows or doors that have white, canvas, Sandtone, forest green, dark bronze or black colors.
- Andersen does not warrant the adhesion or performance of homeowner-applied paint over vinyl or other factory-coated surfaces.
- 400 Series windows in Terratone color may be painted any color lighter than Terratone color using quality oil-based or latex paint.
- For vinyl painting instructions and preparation, contact your Andersen supplier.
- Do not paint weatherstrip.
- Creosote-based stains should not come in contact with Andersen products.
- Abrasive cleaners or solutions containing corrosive solvents should not be used on Andersen products.

For more information about **glass, patterned glass, art glass and grilles**, see pages 12-14.









For more information about **combination designs, product performance, installation instructions and accessories**, see pages 181-211 or visit [andersenwindows.com](http://andersenwindows.com).

Dimensions in parentheses are in millimeters.

# SPECIALTY WINDOWS











**Table of Double-Hung Half Circle and Eyebrow Window Sizes**

Scale 1/8" (3) = 1'-0" (305) – 1:96

Window Dimension	2'-1 5/8" (651)	2'-5 5/8" (752)	2'-9 5/8" (854)	3'-1 5/8" (956)	3'-5 5/8" (1057)
<b>Minimum Rough Opening</b>	2'-2 1/8" (664)	2'-6 1/8" (765)	2'-10 1/8" (867)	3'-2 1/8" (968)	3'-6 1/8" (1070)
Unobstructed Glass (Half Circle)	20 3/8" (518)	24 3/8" (619)	28 3/8" (721)	32 3/8" (822)	36 3/8" (924)
Radius	12 13/16" (325)	14 13/16" (376)	16 13/16" (427)	18 13/16" (478)	20 13/16" (529)
					
	1'-3 3/16" (386) 1'-3 3/4" (400) 10 3/16" (259)	1'-5 3/16" (437) 1'-5 3/4" (451) 12 3/16" (310)	1'-7 3/16" (487) 1'-7 3/4" (502) 14 3/16" (360)	1'-9 3/16" (538) 1'-9 3/4" (552) 16 3/16" (411)	1'-11 3/16" (589) 1'-11 3/4" (603) 18 3/16" (462)
	<b>CTN20</b>	<b>CTN24</b>	<b>CTN28</b>	<b>CTN30</b>	<b>CTN34</b>
			Unobstructed Glass (Eyebrow) 24 7/8" (632)	26 1/8" (664)	32 7/16" (824)
			Radius 18 3/4" (476)	24" (610)	24" (610)
					
			<b>FCD28</b>	<b>FCD30</b>	<b>FCD34</b>
20210, 2032, 2036, 20310, 2042, 2046, 20410, 2052, 2056, 20510, 2062, 2072, 2076	24210, 2432, 2436, 24310, 2442, 2446, 24410, 2452, 2456, 24510, 2462, 2472, 2476	28210, 2832, 2836, 28310, 2842, 2846, 28410, 2852, 2856, 28510, 2862, 2872, 2876	30210, 3032, 3036, 30310, 3042, 3046, 30410, 3052, 3056, 30510, 3062, 3072, 3076	34210, 3432, 3436, 34310, 3442, 3446, 34410, 3452, 3456, 34510, 3462, 3472, 3476	

**Table of Casement/Awning Half Circle, Quarter Circle and Eyebrow Window Sizes**

Scale 1/8" (3) = 1'-0" (305) – 1:96

Window Dimension	2'-0 1/8" (613)	2'-4 3/8" (721)	2'-7 1/2" (800)	2'-11 15/16" (913)	4'-0" (1219)
<b>Minimum Rough Opening</b>	2'-0 5/8" (625)	2'-4 7/8" (733)	2'-8" (813)	3'-0 1/2" (927)	4'-0 1/2" (1232)
Unobstructed Glass (Half & Quarter Circle)	19 1/2" (495)	23 3/4" (603)	26 7/8" (683)	31 5/16" (795)	43 3/8" (1102)
Radius	12 1/16" (306)	14 3/16" (360)	15 3/4" (400)	18" (457)	24" (610)
					
	1'-2 3/8" (365) 1'-2 7/8" (378) 9 3/4" (248)	1'-4 1/2" (419) 1'-5" (432) 11 7/8" (302)	1'-6" (458) 1'-6 1/2" (470) 13 7/16" (341)	1'-8 1/4" (514) 1'-8 3/4" (527) 15 5/8" (397)	2'-2 5/16" (668) 2'-2 7/8" (683) 21 11/16" (551)
	<b>CTC1</b>	<b>CTCW1</b>	<b>CTCX1</b>	<b>CTCXW1</b>	<b>CTC2</b>
	Radius 24" (610)	28 1/4" (718)	31 3/8" (797)	35 13/16" (910)	
					
	<b>CTQC1</b>	<b>CTQCW1</b>	<b>CTQCX1</b>	<b>CTQA3</b>	
				Unobstructed Glass (Eyebrow) 28 15/16" (735)	35 7/8" (911)
				Radius 18 3/4" (476)	32 1/4" (819)
					
				<b>FCCXW3</b>	<b>FCC2</b>
C12, C125, C13, C135, C14, C145, C15, C155, C16, CTR2010, AR21, AN21, A21, AW21, A212, A213	CW12, CW125, CW13, CW135, CW14, CW145, CW15, CW155, CW16, CTR2410, AR251, AN251, A251, AW251, AX251	CX125, CX13, CX135, CX14, CX145, CX15, CX155, CX16, CTR2810, AR281, AN281, A281, AW281, AX281, AXW281	CXW13, CXW135, CXW14, CXW145, CXW15, CXW155, CXW16, CTR3010, PTR3010, P3030, P3035, P3040, P3045, P3050, P3055, P3060, AR31, AN31, A31, AW31, AX31, AXW31, A335, A312, AXW312, A313, AP32V, PA3050, PA3060	C22, C225, C23, C235, C24, C245, C25, C255, C26, CTR4010, CTR22010, PTR4010, AR41, AN41, A41, AW41, AX41, AXW41, AR221, AN221, A221, AW221, P4030, P4035, P4040, P4045, P4050, P4055, P4060, AP24V, PA4060	

\*"Window Dimension" always refers to outside frame to frame dimension.  
 \*"Minimum Rough Opening" dimensions may need to be increased to allow for use of building wraps, flashing, sill panning, brackets, fasteners or other items. See pages 210-211 for more details.  
 \*Dimensions in parentheses are in millimeters.  
 \*Actual radius of 17 31/32" (456).

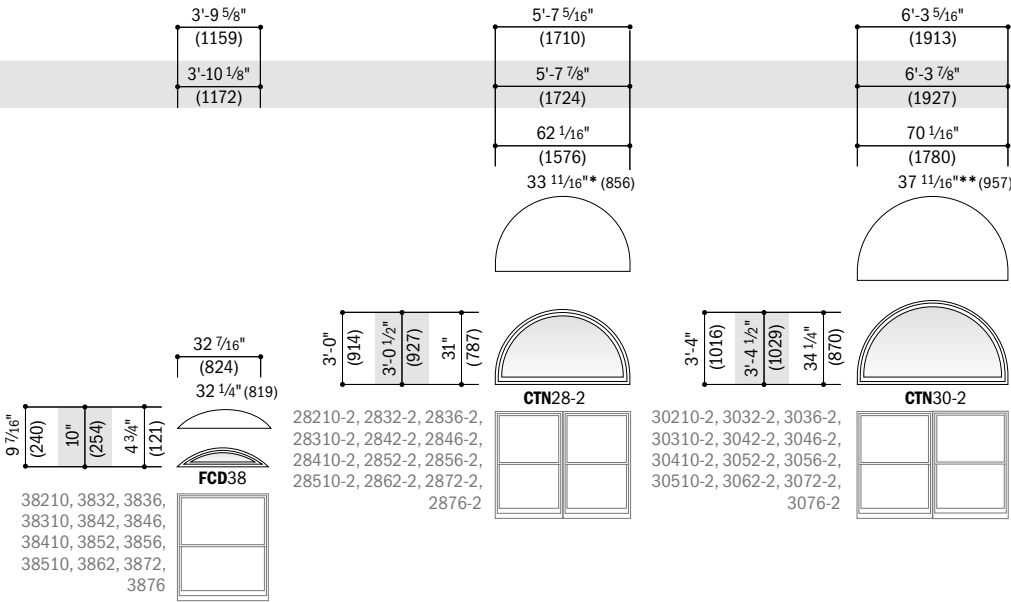

Compatible double-hung, casement, awning and picture windows are shown below specialty windows. Grille patterns shown on page 122.

**Double-Hung Half Circle Window Area Specifications**

Window Number	Glass Area Sq.Ft./ (m <sup>2</sup> )
CTN20	1.1 (0.10)
CTN24	1.6 (0.15)
CTN28	2.2 (0.20)
CTN30	2.8 (0.26)
CTN34	3.6 (0.34)
CTN28-2	10.5 (0.98)
CTN30-2	13.4 (1.25)

**Eyebrow Window Area Specifications**

Window Number	Glass Area Sq.Ft./ (m <sup>2</sup> )
FCD28	0.69 (0.06)
FCD30	0.54 (0.05)
FCD34	1.15 (0.11)
FCD38	0.84 (0.08)
FCCXW3	1.24 (0.12)
FCC2	1.02 (0.09)
FCCW2	2.78 (0.26)

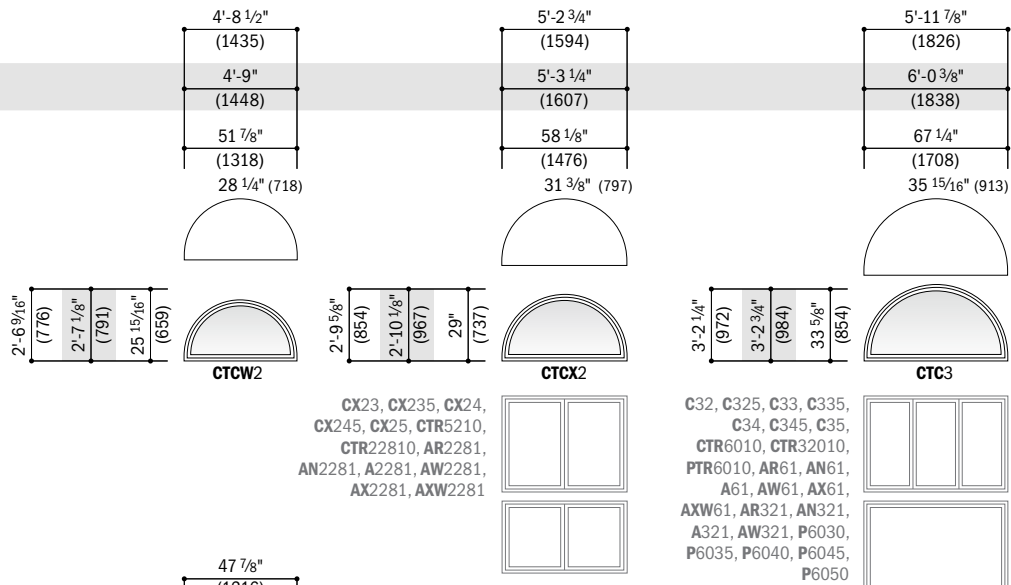

Compatible double-hung, casement, awning and picture windows are shown below specialty windows. Grille patterns shown on page 122.

**Casement/Awning Half Circle Window Area Specifications**

Window Number	Glass Area Sq.Ft./ (m <sup>2</sup> )
CTC1	1.0 (0.09)
CTCW1	1.5 (0.14)
CTCXW1	2.7 (0.25)
CTC2	5.1 (0.47)
CTCW2	7.3 (0.68)
CTC3	12.3 (1.14)
CTCX1	2.0 (0.19)
CTCX2	9.3 (0.86)

**Quarter Circle Window Area Specifications**

Window Number	Glass Area Sq.Ft./ (m <sup>2</sup> )
CTQC1	1.9 (0.18)
CTQCW1	3.0 (0.28)
CTQA3	5.2 (0.48)
CTQCX1	3.8 (0.35)

CW22, CW225, CW23, CW235, CW24, CW245, CW25, CW255, CW26, CTR4810, CTR22410, AR2251, AN2251, A2251, AW2251, AX2251

• "Window Dimension" always refers to outside frame to frame dimension.  
 • "Minimum Rough Opening" dimensions may need to be increased to allow for use of building wraps, flashing, sill panning, brackets, fasteners or other items. See pages 210-211 for more details.  
 • Dimensions in parentheses are in millimeters.  
 \*Actual radius of 33 21/32" (855).  
 \*\*Actual radius of 37 21/32" (956).

• Dimensions in parentheses are in square meters.

# SPECIALTY WINDOWS

## Table of Eyebrow Window Sizes - Patio Doors

Scale 1/8" (3) = 1'-0" (305) – 1:96

Window Dimension	4'-11 1/4" (1504)	5'-11 1/4" (1810)
<b>Minimum Rough Opening</b>	4'-11 3/4" (1518)	5'-11 3/4" (1822)
Unobstructed Glass	49 7/16" (1256)	59 11/16" (1516)
Radius	36" (914)	48" (1219)
	<b>FCFW50</b>	<b>FCFW60</b>
	FWG5068, FWG50611, FWG5080, FWH5068, FWH50611, FWH5080, FWO5068, FWO50611, FWO5080, NLGD5068, NLGD50611, NLGD5080, PS5068, ISPD5068, ISPD50611, ISPD5076, ISPD5080	FWG6068, FWG60611, FWG6080, FWH6068, FWH60611, FWH6080, FWO6068, FWO60611, FWO6080, NLGD6068, NLGD60611, NLGD6080, ISPD6068, ISPD60611, ISPD6076, ISPD6080

Compatible patio doors are shown below specialty windows. Grille patterns shown below.

## Eyebrow Window Area Specifications

Window Number	Glass Area Sq.Ft./ (m <sup>2</sup> )
FCFW50	2.57 (0.24)
FCFW60	3.15 (0.29)

## Elliptical Window Area Specifications

Window Number	Glass Area Sq.Ft./ (m <sup>2</sup> )
ET6	4.3 (0.40)
ET8	8.0 (0.74)

## Circle & Oval Window Area Specifications

Window Number	Glass Area Sq.Ft./ (m <sup>2</sup> )
CIR20	2.1 (0.20)
CIR24	3.0 (0.28)
CIR30	5.2 (0.48)
OVL1824	1.9 (0.18)
OVL2030	3.2 (0.30)
OVL3048	8.7 (0.81)

## Table of Elliptical Window Sizes - Patio Doors

Scale 1/8" (3) = 1'-0" (305) – 1:96

Window Dimension	5'-11 1/4" (1810)	7'-11 1/4" (2419)
<b>Minimum Rough Opening</b>	6'-0" (1829)	8'-0" (2438)
Unobstructed Glass	66 1/4" (1683)	90 1/4" (2292)
	<b>ET6</b>	<b>ET8</b>
	FWG6068, FWG60611, FWG6080, FWH6068, FWH60611, FWH6080, FWO6068, FWO60611, FWO6080, NLGD6068, NLGD60611, NLGD6080, ISID6068, ISID60611, ISID6076, ISID6080	FWG8068, FWG80611, FWG8080, FWH8068, FWH80611, FWH8080, NLGD8068, NLGD80611, NLGD8080

## Gothic & Octagon Window Area Specifications

Window Number	Glass Area Sq.Ft./ (m <sup>2</sup> )
GT2036	4.01 (0.37)
GT2440	5.84 (0.54)
GT3046	8.78 (0.82)
GT4056	14.88 (1.38)
OC20	2.14 (0.20)
OC24	3.12 (0.29)
OC30	5.63 (0.52)

## Monumental Quarter Circle and Circle Area Specifications

Window Number	Glass Area Sq.Ft./ (m <sup>2</sup> )
QR40	9.91 (0.92)
FR40	10.22 (0.95)
FR60	24.69 (2.29)

- \* "Window Dimension" always refers to outside frame to frame dimension.
- \* "Minimum Rough Opening" dimensions may need to be increased to allow for use of building wraps, flashing, sill panning, brackets, fasteners or other items. See pages 210-211 for more details.
- \* Dimensions in parentheses are in millimeters.

\* Dimensions in parentheses are in square meters.

## Grille Patterns

	Renaissance	Colonial		Renaissance	Sunburst
<b>Eyebrow</b>			<b>Half Circle &amp; Quarter Circle</b>		
<b>Circle</b>					
<b>Oval</b>			<b>Elliptical</b>		
<b>Gothic</b>				<b>Monumental Quarter Circle</b>	
<b>Octagon</b>			<b>Monumental Circle</b>		

Patterns for specialty windows may not align with patterns for picture windows when horizontally joined. **Number of lights and overall pattern varies with window size. Patterns are not available in all configurations.** Specified equal light and custom patterns are also available. For more grille options, see page 13 or visit [andersenwindows.com/grilles](http://andersenwindows.com/grilles).

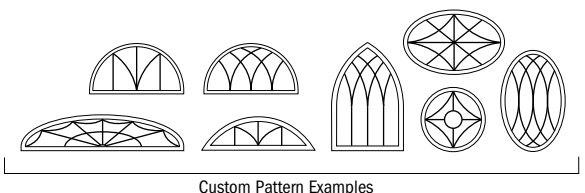

**Table of Circle Window Sizes**

Scale 1/8" (3) = 1'-0" (305) – 1:96

Window Dimension	2'-0 1/8" (613)	2'-4 3/8" (721)	2'-11 15/16" (913)
<b>Minimum Rough Opening</b>	2'-0 5/8" (625)	2'-4 7/8" (733)	3'-0 1/2" (927)
Unobstructed Glass	19 3/4" (502)	24" (610)	31 9/16" (802)

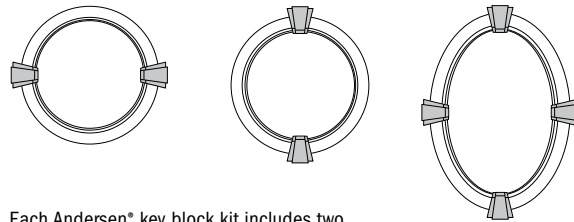
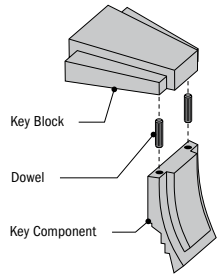

Each Andersen® key block kit includes two key blocks and two key components.

**Table of Oval Window Sizes**

Scale 1/8" (3) = 1'-0" (305) – 1:96

Window Dimension	1'-7 3/4" (502)	2'-0" (610)	3'-0" (914)
<b>Minimum Rough Opening</b>	1'-8 1/4" (514)	2'-0 1/2" (622)	3'-0 1/2" (927)
Unobstructed Glass	15 3/8" (391)	19 3/8" (492)	31 3/8" (797)

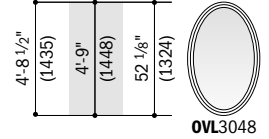
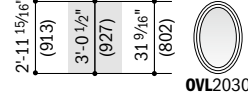
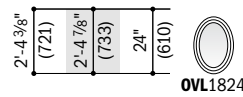

Oval windows can be installed either vertically or horizontally.

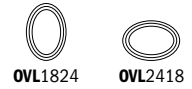

Circle, oval, gothic, octagon and monumental specifications shown on page 122. Grille patterns shown on page 122.

**Table of Extended Gothic Window Sizes**

Scale 1/8" = 1'-0" (1:96)

Window Dimension	2'-0 1/8" (613)	2'-4 3/8" (721)	2'-11 15/16" (913)	4'-0" (1219)
<b>Minimum Rough Opening</b>	2'-0 5/8" (625)	2'-4 7/8" (733)	3'-0 1/2" (927)	4'-0 1/2" (1232)
Unobstructed Glass	19 7/16" (495)	23 11/16" (602)	31 1/4" (794)	43 5/16" (110)
Radius	32 1/4" (819)	32 1/4" (819)	36" (914)	48" (1219)

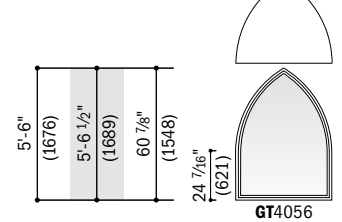
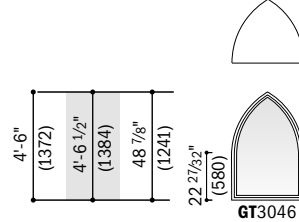
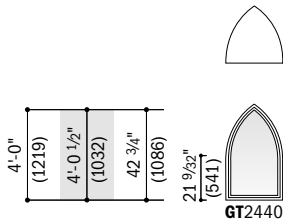
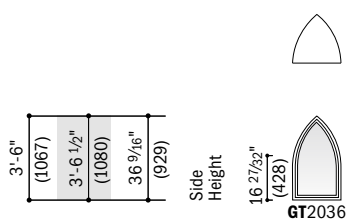

**Table of Octagon Window Sizes**

Scale 1/8" (3) = 1'-0" (305) – 1:96

Window Dimension	2'-0" (610)	2'-4" (711)	3'-0" (914)
<b>Minimum Rough Opening</b>	2'-0 1/2" (622)	2'-4 1/2" (724)	3'-0 1/2" (927)
Unobstructed Glass	19 5/16" (491)	23 5/16" (592)	31 5/16" (795)

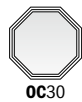

**Table of Monumental Quarter Circle & Circle Window Sizes**

Scale 1/8" (3) = 1'-0" (305) – 1:96

Window Dimension	4'-0" (1219)	4'-0" (1219)	6'-0" (1829)
<b>Minimum Rough Opening</b>	4'-0 1/2" (1232)	4'-0 1/2" (1232)	6'-0 1/2" (1842)
Unobstructed Glass	43 1/4" (1099)	43 5/16" (1100)	67 5/16" (1710)
Radius	48" (1219)	24" (610)	36" (914)



\*"Window Dimension" always refers to outside frame to frame dimension.  
 \*\*"Minimum Rough Opening" dimensions may need to be increased to allow for use of building wraps, flashing, sill panning, brackets, fasteners or other items. See pages 210-211 for more details.  
 •Dimensions in parentheses are in millimeters.

400 Series  
Specialty Windows

# SPECIALTY WINDOWS

## Double-Hung Half Circle Window Detail

Scale 1 1/2" (38) = 1'-0" (305) – 1:8

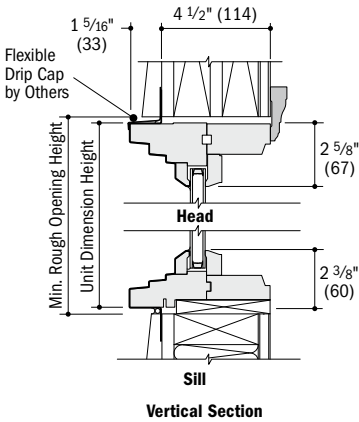

## Casement/Awning Half Circle Window Detail

Scale 1 1/2" (38) = 1'-0" (305) – 1:8

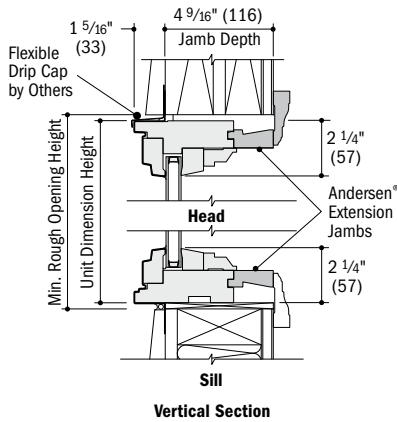

## Casement/Awning Quarter Circle Window Detail

Scale 1 1/2" (38) = 1'-0" (305) – 1:8

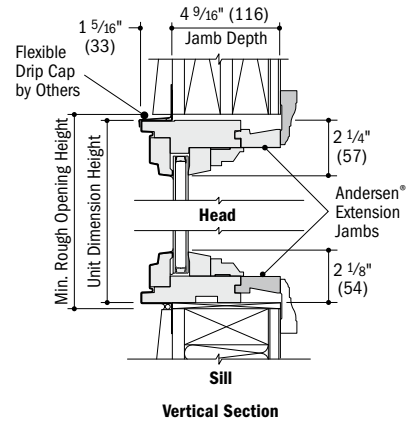

## Eyebrow Window Details

Scale 1 1/2" (38) = 1'-0" (305) – 1:8

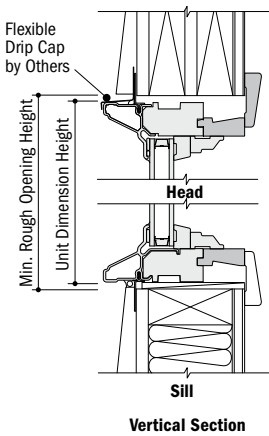

## Gothic Window Details

Scale 1 1/2" (38) = 1'-0" (305) – 1:8

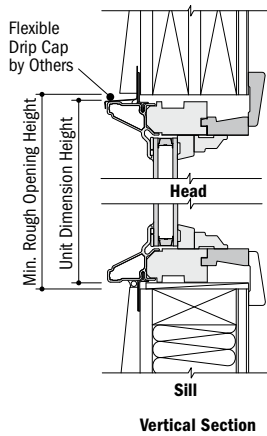

## Octagon Window Details

Scale 1 1/2" (38) = 1'-0" (305) – 1:8

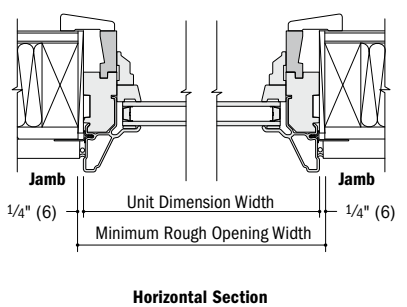
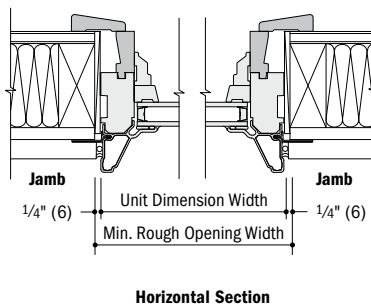
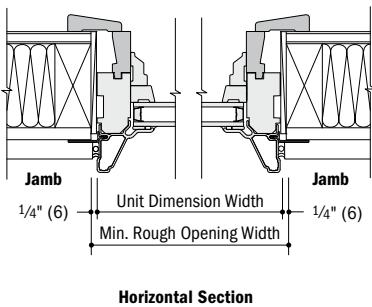
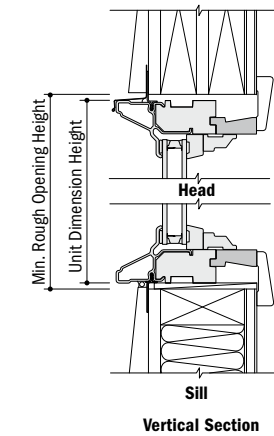

• 4 9/16" (116) jamb depth measurement is from back side of installation flange.

• Light-colored areas are parts included with window. Dark-colored areas are additional Andersen® parts required to complete window assembly as shown.

• **Rough openings may need to be increased to allow for use of building wraps, flashing, sill panning, brackets, fasteners or other items. See installation information on pages 210-211.**

• Details are for illustration only and are not intended to represent product installation methods or materials. Refer to product installation guides at [andersenwindows.com](http://andersenwindows.com).

• Dimensions in parentheses are in millimeters.

**Elliptical Window Detail**

Scale 1 1/2" (38) = 1'-0" (305) – 1:8

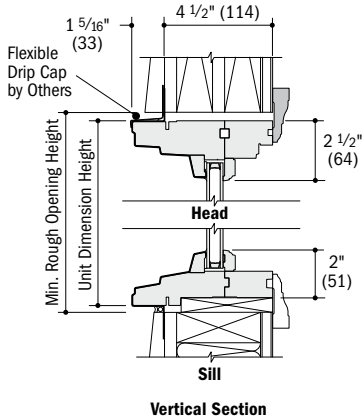

**Circle Window Detail**

Scale 1 1/2" (38) = 1'-0" (305) – 1:8

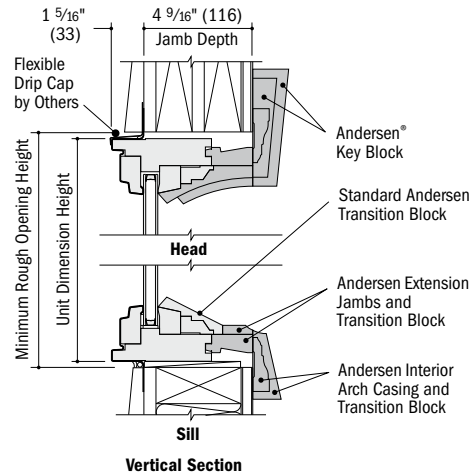

**Oval Window Detail**

Scale 1 1/2" (38) = 1'-0" (305) – 1:8

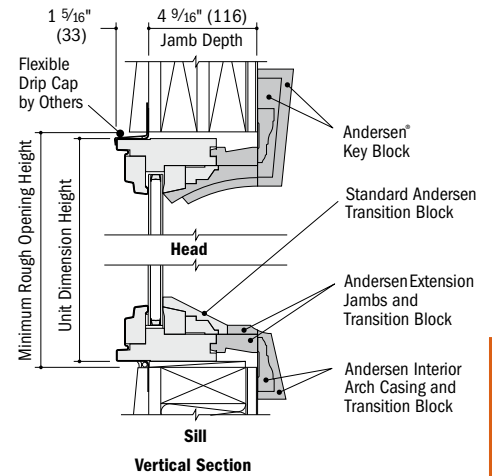

**Monumental Quarter Circle Window Details**

Scale 1 1/2" (38) = 1'-0" (305) – 1:8

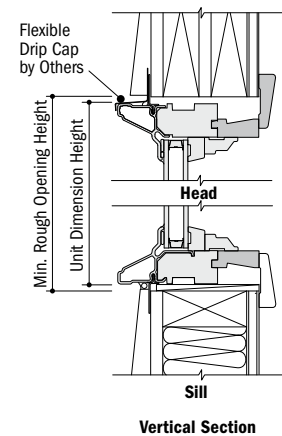

**Monumental Circle Window Details**

Scale 1 1/2" (38) = 1'-0" (305) – 1:8

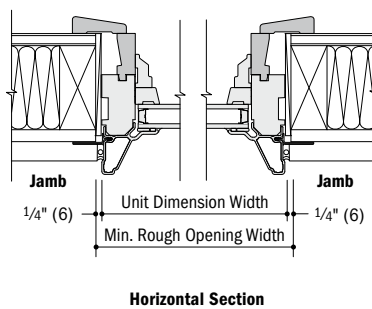
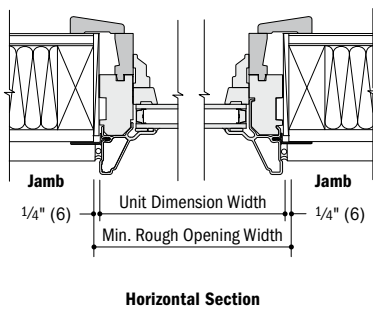
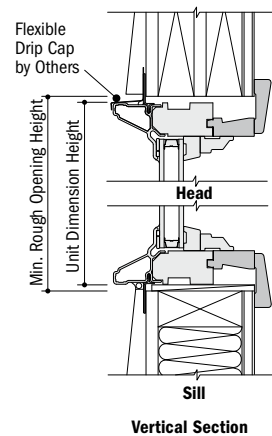

- 4 9/16" (116) jamb depth measurement is from back side of installation flange.
- Light-colored areas are parts included with window. Dark-colored areas are additional Andersen® parts required to complete window assembly as shown.
- **Rough openings may need to be increased to allow for use of building wraps, flashing, sill panning, brackets, fasteners or other items. See installation information on pages 210-211.**
- Details are for illustration only and are not intended to represent product installation methods or materials. Refer to product installation guides at andersenwindows.com.
- Dimensions in parentheses are in millimeters.

# SPECIALTY WINDOWS

## Horizontal (stack) Joining Details

Scale 1 1/2" (38) = 1'-0" (305) – 1:8

### Casement Half Circle over Casement Window

#### Overall Window Dimension Height

Sum of individual window heights plus 1/8" (3) for each join.

#### Overall Rough Opening Height

Overall window dimension height plus 5/8" (16).

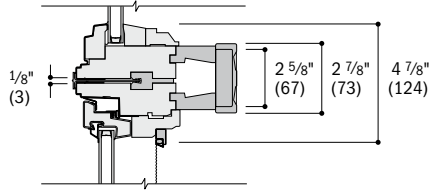

Vertical Section

### Double-Hung Half Circle over Tilt-Wash Double-Hung Window

#### Overall Window Dimension Height

Sum of individual window heights plus 0" for each join.

#### Overall Rough Opening Height

Overall window dimension height plus 3/8" (10).

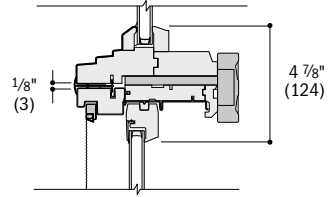

Vertical Section

### Elliptical Window over Frenchwood® Gliding Patio Door

#### Overall Unit Dimension Height

Sum of individual unit heights plus 3/8" (10).

#### Overall Rough Opening Height

Overall unit dimension height plus 5/8" (16).

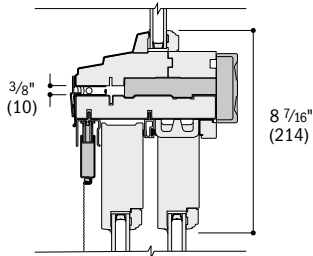

Vertical Section

### Elliptical Window over Frenchwood® Hinged Inswing Patio Door

#### Overall Unit Dimension Height

Sum of individual unit heights plus 1/8" (3).

#### Overall Rough Opening Height

Overall unit dimension height plus 1" (25).

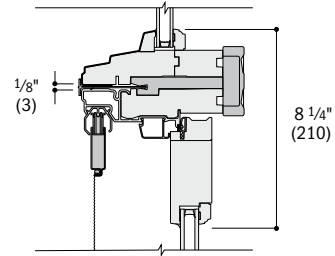

Vertical Section

### Elliptical Window over Perma-Shield® Gliding Patio Door

#### Overall Unit Dimension Height

Sum of individual unit heights plus 3/8" (10).

#### Overall Rough Opening Height

Overall unit dimension height plus 5/8" (16).

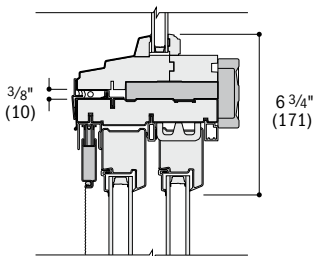

Vertical Section

For more joining information see the combination designs section starting on page 181.

\* Light-colored areas are parts included with window. Dark-colored areas are additional Andersen® parts required to complete window assembly as shown.  
 • **Rough openings may need to be increased to allow for use of building wraps, flashing, sill panning, brackets, fasteners or other items. See installation information on pages 210-211.**  
 • Details are for illustration only and are not intended to represent product installation methods or materials. Refer to product installation guides at andersenwindows.com.  
 • Consult with an architect or structural engineer regarding minimum requirements for structural support members between adjacent rough openings.  
 • Dimensions in parentheses are in millimeters.

**Custom Arch Windows**

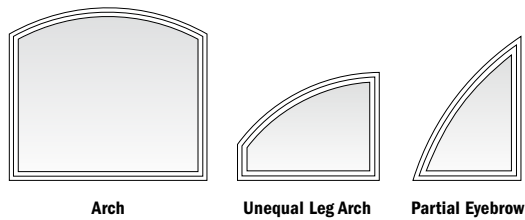

Andersen offers even greater design flexibility with custom-dimensioned arch, unequal leg arch and partial eyebrow windows. Custom arch windows can be designed using one of 10 standard radii, further expanding the existing line of 90 standard sizes of Andersen® arch windows.

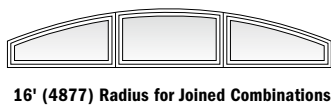

Custom arch shapes and sizes are specially constructed to be used in combination with other Andersen windows, including casement, awning, double-hung, gliding and Flexiframe® windows and hinged or gliding patio doors.

Andersen grilles are available for most styles and sizes. Contact your supplier for availability.

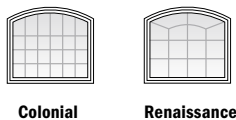

**Design Criteria**

Listed below are some factors that must be considered when deciding on a custom arch size and shape. For specific design criteria, joining instructions and order information, contact your Andersen supplier.



- **Do all calculations in inches to 3 decimal places**
- **Order extension jambs along with window for correct sizing**
- **All units are fixed**
- **Maximum standard glass area of 60 sq. ft. or 5.57 m<sup>2</sup>**
- **Ten standard radii:**  
18 3/4" (476), 2' (610), 32 1/4" (819), 34 1/4" (870), 3' (914), 4' (1219), 5' (1524), 6' (1829), 8' (2438), 16' (4877)
- **Maximum radii:** based on available radius piece length, contact supplier for specific information
- **Maximum equal leg arch unit width:**  
36 3/4" (399) for 18 3/4" (476) radius to 12' (3658) for 16' (4877) radius
- **Maximum unequal leg arch unit width:**  
18 3/4" (476) for 18 3/4" radius to 11'-2" (3404) for 16' (4877) radius
- **Maximum partial eyebrow unit width:**  
18 3/4" (476) for 18 3/4" radius to 11'-5 1/2" (3493) for 16' (4877) radius
- **Only one dimension, height or width can exceed 7'-0" (2134)**
- **No height dimension greater than 12'-0" (3658)**
- **No leg dimension less than 6" (152)**

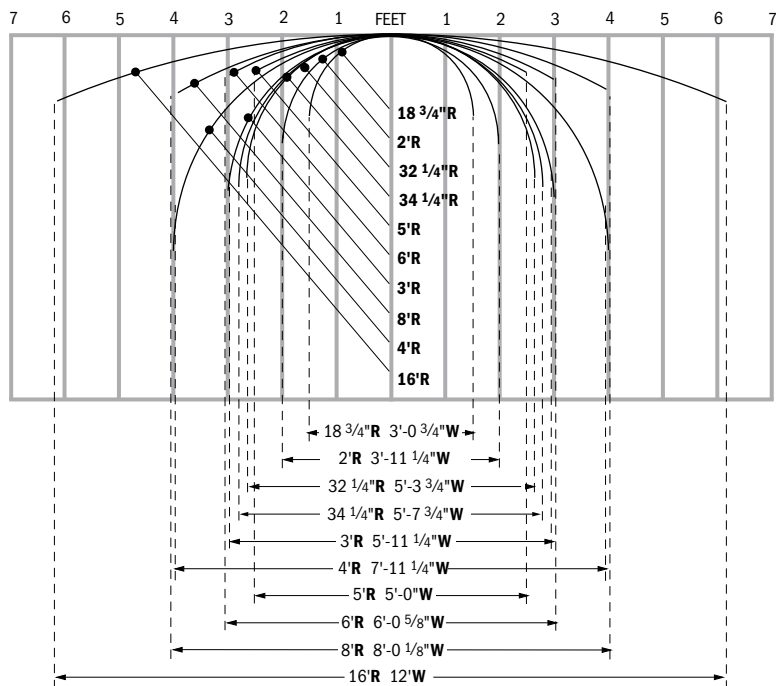

**Standard Radii & Maximum Unit Width for Custom Arch Windows**

\* Dimensions in parentheses are in millimeters.



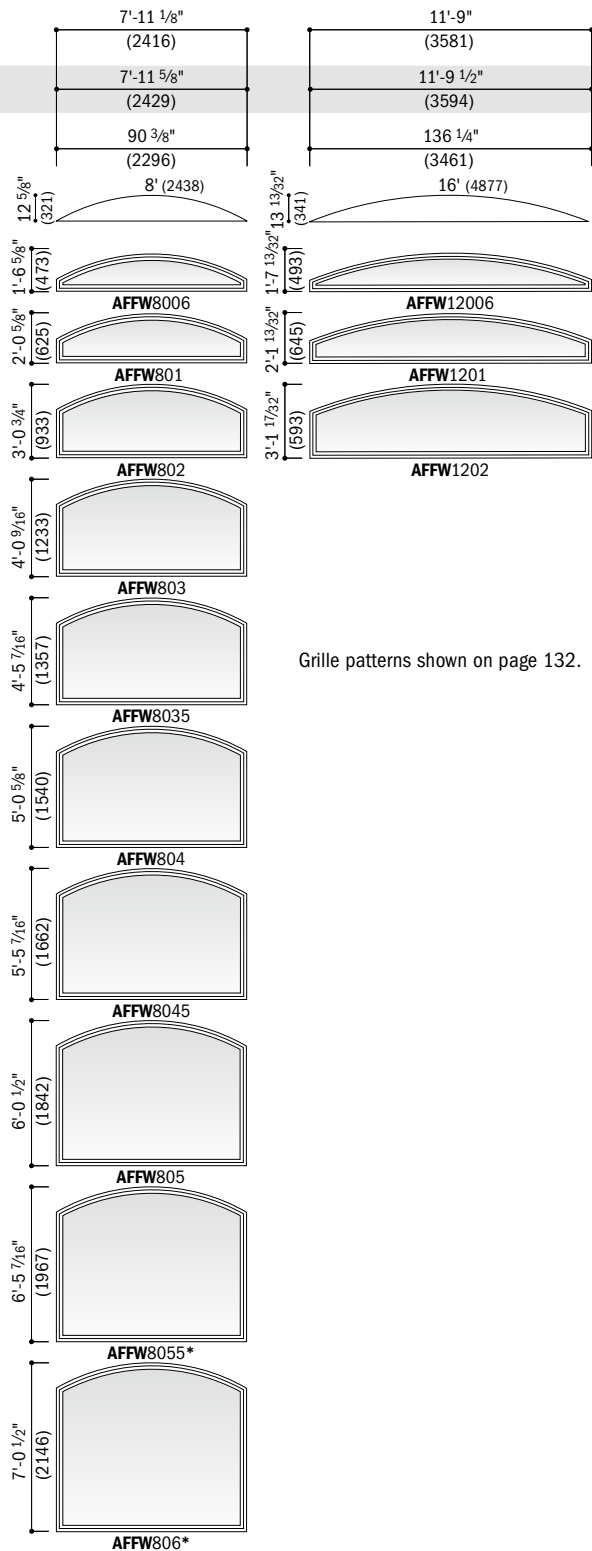

Grille patterns shown on page 132.

**Arch Window Area Specifications**

Window Number	Glass Area Sq.Ft./ (m <sup>2</sup> )	Window Number	Glass Area Sq.Ft./ (m <sup>2</sup> )
AFC106	0.7 (0.07)	AFCW22	9.5 (0.88)
AFC11	1.6 (0.15)	AFCW23	13.9 (1.29)
AFC12	3.4 (0.32)	AFCW235	15.7 (1.46)
AFC13	5.1 (0.47)	AFCW24	18.3 (1.70)
AFC135	5.8 (0.54)	AFCW245	20.1 (1.87)
AFC14	6.8 (0.63)	AFCW25	22.7 (2.11)
AFC145	7.5 (0.70)	AFCW255	24.6 (2.29)
AFC15	8.5 (0.79)	AFCW26	27.2 (2.53)
AFC155	9.2 (0.86)	AFCW28	36.1 (3.35)
AFC16	10.3 (0.96)	AFFW5006	3.2 (0.30)
AFC18	13.8 (1.28)	AFFW501	5.5 (0.51)
AFCW106	1.1 (0.10)	AFFW502	10.3 (0.96)
AFCW11	2.1 (0.20)	AFFW503	14.8 (1.38)
AFCW12	4.2 (0.39)	AFFW5035	16.7 (1.55)
AFCW13	6.3 (0.59)	AFFW504	19.5 (1.81)
AFCW135	7.1 (0.66)	AFFW5045	21.4 (1.99)
AFCW14	8.4 (0.78)	AFFW505	24.1 (2.24)
AFCW145	9.2 (0.86)	AFFW5055	26.1 (2.43)
AFCW15	10.4 (0.97)	AFFW506	28.8 (2.68)
AFCW155	11.3 (1.05)	AFFW508	38.2 (3.55)
AFCW16	12.5 (1.16)	AFFW6006	4.4 (0.41)
AFCW18	16.8 (1.56)	AFFW601	7.2 (0.67)
AFCP3006	1.4 (0.13)	AFFW602	12.9 (1.20)
AFCP301	2.8 (0.26)	AFFW603	18.5 (1.72)
AFCP302	5.5 (0.51)	AFFW6035	20.8 (1.93)
AFCP303	8.2 (0.76)	AFFW604	24.2 (2.25)
AFCP3035	9.3 (0.86)	AFFW6045	26.5 (2.46)
AFCP304	10.9 (1.01)	AFFW605	29.8 (2.77)
AFCP3045	12.0 (1.12)	AFFW6055	32.1 (2.98)
AFCP305	13.6 (1.26)	AFFW606	35.5 (3.30)
AFCP3055	14.7 (1.37)	AFFW608	46.9 (4.36)
AFCP306	16.3 (1.51)	AFFW8006	7.3 (0.68)
AFCP308	21.8 (2.03)	AFFW801	11.1 (1.03)
AFC206	2.2 (0.20)	AFFW802	18.8 (1.75)
AFC21	4.1 (0.38)	AFFW803	26.4 (2.45)
AFC22	7.8 (0.73)	AFFW8035	29.5 (2.74)
AFC23	11.5 (1.07)	AFFW804	34.1 (3.17)
AFC235	13.0 (1.21)	AFFW8045	37.1 (3.45)
AFC24	15.2 (1.41)	AFFW805	41.6 (3.87)
AFC245	16.7 (1.55)	AFFW8055	44.8 (4.16)
AFC25	18.9 (1.76)	AFFW806	49.3 (4.58)
AFC255	20.4 (1.90)	AFFW12006	9.9 (0.92)
AFC26	22.6 (2.10)	AFFW1201	15.6 (1.45)
AFC28	30.2 (2.81)	AFFW1202	27.1 (2.52)
AFCW206	2.8 (0.26)		
AFCW21	5.1 (0.47)		

\* Dimensions in parentheses are in square meters.

\* "Window Dimension" always refers to outside frame to frame dimension.  
 \*\* "Minimum Rough Opening" dimensions may need to be increased to allow for use of building wraps, flashing, sill panning, brackets, fasteners or other items. See pages 210-211 for more details.  
 • Dimensions in parentheses are in millimeters.  
 \* Tempered glass standard.

# SPECIALTY WINDOWS

**Table of Springline™ Window Sizes**

Scale 1/8" (3) = 1'-0" (305) - 1.96

Notes on the next page also apply to this page.

Window Width Dimension	Minimum Rough Opening	Unobstructed Glass	Radius	Window height shown in table	Chord Height	Side Height	Minimum Rough Opening = window height + 1/2" (13)		Unobstructed Glass = window height - 4 3/4" (121)	
3'-1 1/2" (953)	3'-2" (965)	32 3/4" (832)	18 3/4" (476)	6" (152)	12" (305)	SE3106	4'-11 7/8" (1521)	4'-4 13/16" (1341)	SE3145	
4'-0" (1219)	4'-0 1/2" (1232)	43 1/4" (1099)	24" (610)	6" (152)	12" (305)	SE311	6'-6 5/8" (1997)	5'-11 9/16" (1818)	SE3145	
5'-4 1/2" (1638)	5'-5" (1651)	59 3/4" (1518)	32 1/4" (819)	6" (152)	12" (305)	SE313	6'-11 7/8" (2130)	6'-4 13/16" (1951)	SP4045	
5'-8 1/2" (1740)	5'-9" (1753)	63 3/4" (1619)	34 1/4" (870)	6" (152)	12" (305)	SE312	7'-8 1/8" (2340)	7'-1 1/16" (2161)	SE3145	
5'-11 1/4" (1810)	5'-11 3/4" (1822)	66 1/2" (1689)	36" (914)	6" (152)	12" (305)	SE3106	7'-10 1/8" (2391)	7'-3 1/16" (2211)	SE3145	
6'-0" (1829)	6'-0 1/2" (1842)	67 1/4" (1708)	36" (914)	6" (152)	12" (305)	SE313	7'-11 7/8" (2435)	7'-4 13/16" (2256)	SE3145	
						SE3106				
						SE311				
						SE313				
						SE312				
						SE3106				
						SE311				
						SE313				
						SE312				
						SE3106				
						SE311				
						SE313				
						SE312				
						SE3106				
						SE311				
						SE313				
						SE312				
						SE3106				
						SE311				
						SE313				
						SE312				
						SE3106				
						SE311				
						SE313				
						SE312				
						SE3106				
						SE311				
						SE313				
						SE312				
						SE3106				
						SE311				
						SE313				
						SE312				
						SE3106				
						SE311				
						SE313				
						SE312				
						SE3106				
						SE311				
						SE313				
						SE312				
						SE3106				
						SE311				
						SE313				
						SE312				
						SE3106				
						SE311				
						SE313				
						SE312				
						SE3106				
						SE311				
						SE313				
						SE312				
						SE3106				
						SE311				
						SE313				
						SE312				
						SE3106				
						SE311				
						SE313				
						SE312				
						SE3106				
						SE311				
						SE313				
						SE312				
						SE3106				
						SE311				
						SE313				
						SE312				
						SE3106				
						SE311				
						SE313				
						SE312				
						SE3106				
						SE311				
						SE313				
						SE312				
						SE3106				
						SE311				
						SE313				
						SE312				
						SE3106				
						SE311				
						SE313				
						SE312				
						SE3106				
						SE311				
						SE313				
						SE312				
						SE3106				
						SE311				
						SE313				
						SE312				
						SE3106				
						SE311				
						SE313				
						SE312				
						SE3106				
						SE311				
						SE313				
						SE312				
						SE3106				
						SE311				
						SE313				
						SE312				
						SE3106				
						SE311				
						SE313				
						SE312				
						SE3106				
						SE311				
						SE313				
						SE312				
						SE3106				
						SE311				
						SE313				
						SE312				
						SE3106				
						SE311				
						SE313				
						SE312				
						SE3106				
						SE311				
						SE313				
						SE312				
						SE3106				
						SE311				
						SE313				
						SE312				
						SE3106				
						SE311				
						SE313				
						SE312				
						SE3106				
						SE311				
						SE313				
						SE312				
						SE3106				
						SE311				
						SE313				
						SE312				
						SE3106				
						SE311				
						SE313				
						SE312				
						SE3106				
						SE311				
						SE313				
						SE312				
						SE3106				
						SE311				
						SE313				
						SE312				
						SE3106				
						SE311				
						SE313				
						SE312				
						SE3106				
						SE311				
						SE313				
						SE312				
						SE3106				
						SE311				
						SE313				
						SE312				
						SE3106				
						SE311				
						SE313				
						SE312				
						SE3106				
						SE311				
						SE313				
						SE312				
						SE3106				
						SE311				
						SE313				
						SE312				
						SE3106				

**Springline™ Window Area Specifications**

Window Number	Glass Area Sq.Ft./ (m <sup>2</sup> )
SE3106	3.74 (0.35)
SE311	5.10 (0.47)
SE312	7.86 (0.73)
SE313	10.54 (0.98)
SE3135	11.65 (1.08)
SE314	13.28 (1.23)
SE3145	14.38 (1.34)
SE315	15.98 (1.49)
SE3155	17.10 (1.59)
SE316	18.71 (1.74)
SE5406	11.22 (1.04)
SE541	13.71 (1.27)
SE542	18.74 (1.74)
SE543	23.64 (2.20)
SE5435	25.66 (2.38)
SE544	28.64 (2.66)
SE5445	30.64 (2.85)
SE545	33.57 (3.12)
SE5455	35.61 (3.31)
SE546	38.54 (3.58)
SE5806	12.67 (1.18)
SE581	15.33 (1.42)
SE582	20.69 (1.92)
SE583	25.92 (2.41)
SE5835	28.08 (2.61)
SE584	31.26 (2.90)
SE5845	33.39 (3.10)
SE585	36.51 (3.39)
SE5855	38.70 (3.60)
SE586	41.82 (3.89)
SE6006	14.01 (1.30)
SE601	16.81 (1.56)
SE602	22.47 (2.09)
SE603	27.98 (2.60)
SE6035	30.26 (2.81)
SE604	33.61 (3.12)
SE6045	35.86 (3.33)
SE605	39.16 (3.64)
SE6055	41.46 (3.85)
SE606	44.76 (4.16)
SP402	11.62 (1.08)
SP403	15.16 (1.41)
SP4035	16.63 (1.55)
SP404	18.78 (1.75)
SP4045	20.23 (1.88)
SP405	22.35 (2.08)
SP4055	23.83 (2.21)
SP406	25.95 (2.41)
SP8006	24.98 (2.32)
SP801	24.98 (2.32)
SP802	36.46 (3.39)
ELFW6006	11.58 (1.08)
ELFW601	14.35 (1.33)
ELFW602	19.95 (1.85)
ELFW8006	20.88 (1.94)
ELFW801	24.64 (2.29)
ELFW802	32.25 (3.00)

\* Dimensions in parentheses are in square meters.

400 Series  
Specialty Windows

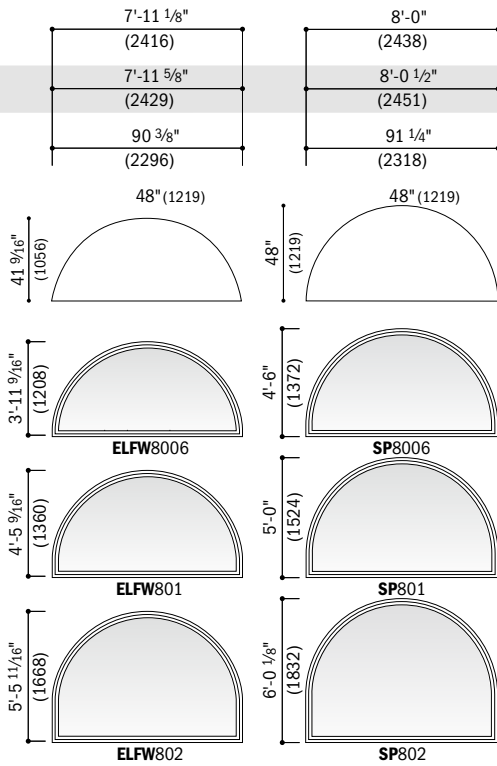

continued on next page

Extension jambs are available factory applied when ordered at the same time as Springline™ windows.

Grille patterns shown on page 132.

\* "Window Dimension" always refers to outside frame to frame dimension.  
 \*\* "Minimum Rough Opening" dimensions may need to be increased to allow for use of building wraps, flashing, sill panning, brackets, fasteners or other items. See pages 210-211 for more details.  
 • Dimensions in parentheses are in millimeters.  
 \* Tempered glass standard.

# SPECIALTY WINDOWS

**Table of Springline™ Window Sizes** (continued)

Scale 1/8" (3) = 1'-0" (305) – 1:96

Window Width Dimension	3'-1 1/2" (953)	4'-0" (1219)	5'-4 1/2" (1638)	5'-8 1/2" (1740)	6'-0" (1829)
<b>Minimum Rough Opening</b>	3'-2" (965)	4'-0 1/2" (1232)	5'-5" (1651)	5'-9" (1753)	6'-0 1/2" (1842)
Unobstructed Glass	32 3/4" (832)	43 1/4" (1099)	59 3/4" (1518)	63 3/4" (1619)	67 1/4" (1708)
Radius	18 3/4" (476)	24" (610)	32 1/4" (819)	34 1/4" (870)	36" (914)
Window height shown in table	Chord Height 18 3/4" (476)	24" (610)	32 1/4" (819)	34 1/4" (870)	36" (914)

**Minimum Rough Opening = window height + 1/2"** (13)  
**Unobstructed Glass = window height - 4.3/4"** (121)

Side Height	SE3155	SP4055	SE5455	SE5855*	SE6055*
5'-4 13/16" (1646)	6'-11 9/16" (2122)	7'-4 13/16" (2256)	8'-1 1/16" (2465)	8'-3 1/16" (2515)	8'-4 13/16" (2561)
5'-11 7/8" (1826)	7'-6 5/8" (2302)	7'-11 7/8" (2435)	8'-8 1/8" (2645)	8'-10 5/8" (2708)	8'-11 7/8" (2740)

Table is continued from page 130.

Extension jambs are available factory applied when ordered at the same time as Springline™ windows. Grille patterns shown below.

\* "Window Dimension" always refers to outside frame to frame dimension.  
 \* "Minimum Rough Opening" dimensions may need to be increased to allow for use of building wraps, flashing, sill panning, brackets, fasteners or other items. See pages 210-211 for more details.  
 \* Dimensions in parentheses are in millimeters.  
 \* Tempered glass standard.

## Grille Patterns

	Colonial	Renaissance	Sunburst
<b>Arch</b>			
<b>Springline™</b>			
<b>Springline™ Flanker</b>			

**Number of lights and overall pattern varies with window size. Patterns are not available in all configurations.**  
 Specified equal light and custom patterns are also available. For more grille options, see page 13 or visit [andersenwindows.com/grilles](http://andersenwindows.com/grilles).

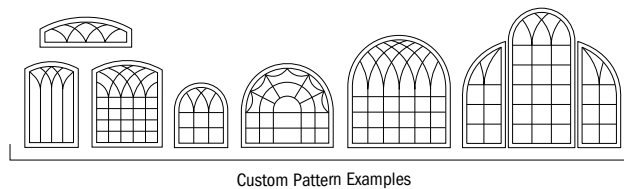

**Table of Springline™ Flanker Window Sizes**

Scale 1/8" (3) = 1'-0" (305) – 1:96

Window Dimension	1'-5" (432)	1'-5" (432)	1'-8 1/2" (521)	1'-8 1/2" (521)	2'-0 1/8" (613)	2'-0 1/8" (613)	2'-4 3/8" (721)	2'-4 3/8" (721)	2'-11 15/16" (913)	2'-11 15/16" (913)
<b>Minimum Rough Opening</b>	1'-5 1/2" (445)	1'-5 1/2" (445)	1'-9" (533)	1'-9" (533)	2'-0 5/8" (625)	2'-0 5/8" (625)	2'-4 7/8" (733)	2'-4 7/8" (733)	3'-0 1/2" (927)	3'-0 1/2" (927)
Unobstructed Glass	12 3/4" (324)	12 3/4" (324)	15 3/4" (400)	15 3/4" (400)	19 3/8" (492)	19 3/8" (492)	23 5/8" (600)	23 5/8" (600)	31 3/16" (792)	31 3/16" (792)
Radius	CR 18 3/4" (476)		CN 24" (610)		C 32 1/4" (819)		CW 32 1/4" (819)		CXW 36" (914)	
Chord Height	18 5/8" (473)		23 11/16" (584)		31 3/16" (792)		32" (813)		36" (914)	
Side Height	2'-11 15/16" (913)		3'-0 1/2" (927)		3'-0 1/2" (927)		3'-0 1/2" (927)		3'-0 1/2" (927)	
Side Height	3'-4 13/16" (1037)		3'-5 3/8" (1051)		3'-5 3/8" (1051)		3'-5 3/8" (1051)		3'-5 3/8" (1051)	
Side Height	4'-0" (1219)		4'-0 1/2" (1232)		4'-0 1/2" (1232)		4'-0 1/2" (1232)		4'-0 1/2" (1232)	
Side Height	4'-11 7/8" (1521)		5'-0 3/8" (1534)		5'-0 3/8" (1534)		5'-0 3/8" (1534)		5'-0 3/8" (1534)	
Side Height	5'-11 7/8" (1826)		6'-0 3/8" (1838)		6'-0 3/8" (1838)		6'-0 3/8" (1838)		6'-0 3/8" (1838)	

- \* "Window Dimension" always refers to outside frame to frame dimension.
- \* "Minimum Rough Opening" dimensions may need to be increased to allow for use of building wraps, flashing, sill panning, brackets, fasteners or other items. See pages 210-211 for more details.
- \* Dimensions in parentheses are in millimeters.

Window dimensions shown in table are compatible with standard casement window widths (CR, CN, C, CW, CXW) and heights (C3, C35, C4, C5, C6). Grille patterns shown on page 132.

Examples:

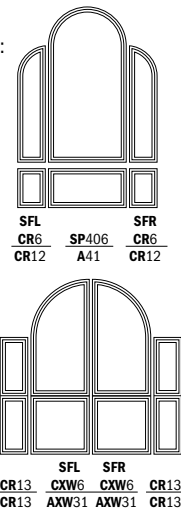

400 Series  
Specialty Windows

**Arch Window Details**

Scale 1 1/2" (38) = 1'-0" (305) – 1:8

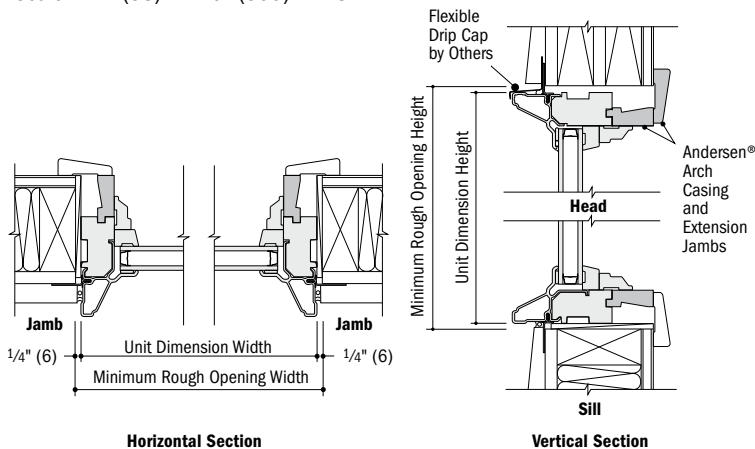

**Springline™ Window Details**

Scale 1 1/2" (38) = 1'-0" (305) – 1:8

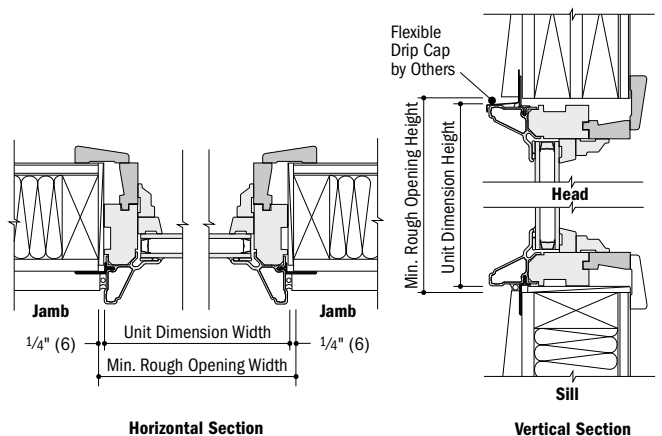

- \* Light-colored areas are parts included with window. Dark-colored areas are additional Andersen® parts required to complete window assembly as shown.
- \* Rough openings may need to be increased to allow for use of building wraps, flashing, sill panning, brackets, fasteners or other items. See installation information on pages 210-211.
- \* Details are for illustration only and are not intended to represent product installation methods or materials. Refer to product installation guides at andersenwindows.com.
- \* Dimensions in parentheses are in millimeters.

# SPECIALTY WINDOWS

## Flexiframe® Window Shapes and Design Criteria

### Minimum and Maximum Limits

Flexiframe windows are available in many shapes and sizes with these limitations:

- **Maximum standard glass area of 60 sq.ft. or 5.57 m<sup>2</sup>**
- **Square footage is based on a square or rectangular shape**
- **No angle may be less than 14°**
- **No leg may be less than 6" (152) or greater than 144" (3658)**
- **No short side may be greater than 84" (2134)**
- **See product information below for additional limitations based on specific shapes**



### Triangle

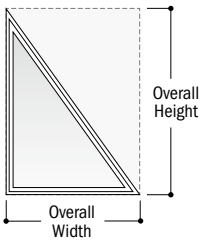

**Right triangles** contain one 90° corner. Specify overall width and overall height extending from the 90° corner.

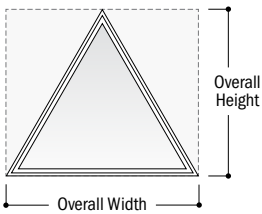

**Isosceles triangles** contain two sides of equal length and equal angle. Specify overall width and overall height (sill to peak).

### Octagon

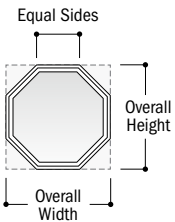

**Octagons** contain eight equal angles and sides. Specify length of equal side. Standard-size octagons are available in 2' (610), 2'-4" (711) and 3' (914) dimensions. See page 123.

### Parallelogram

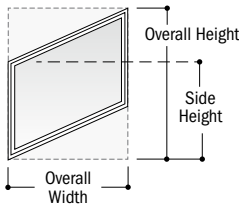

**Parallelograms** contain two pairs of parallel sides. Specify overall width along with side height and overall window height.

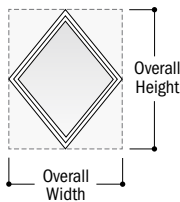

**Diamonds** contain two pairs of parallel and equal length sides. Specify overall width and overall height.

### Hexagon

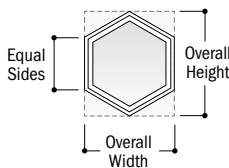

**Hexagons** contain six equal angles and sides. Specify length of equal side.

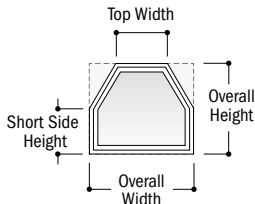

**Unequal hexagons** contain three pairs of angles and two sets of equal length sides. Top side is parallel to and is centered over the sill. Specify overall width, top width, short side height and overall height.

### Rectangle

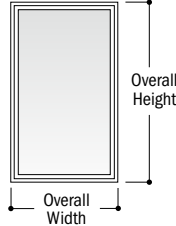
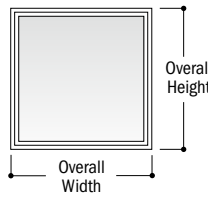

**Rectangles** contain four equal angles and two equal sides for rectangles or four equal sides for squares. Specify overall width and overall height.

### Trapezoid

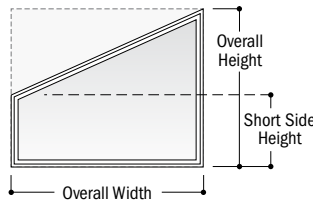
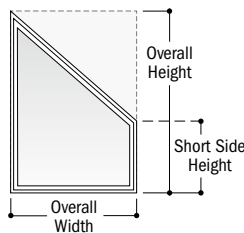

**Trapezoids** contain angle face cut to left or right. Specify overall width along with short side height and overall height. Window's pitch is often designed to match a roof's pitch.

### Pentagon

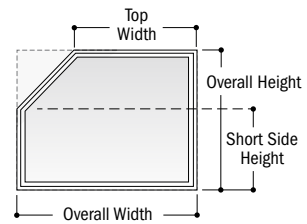

**Angled pentagons** contain an angle cut, or a "cut-off corner" sloping to left or right. Specify overall width and top width along with short side height and overall height.

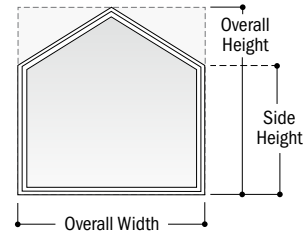

**Peak pentagons** contain sides of equal length, extending at right angles from the sill, and two angled sides, of equal length, that peak above center of sill. Specify overall width, side height and overall height.

\*Dimensions in parentheses are in millimeters.

**Flexiframe® Window Detail**

Scale 1 1/2" (38) = 1'-0" (305) – 1:8

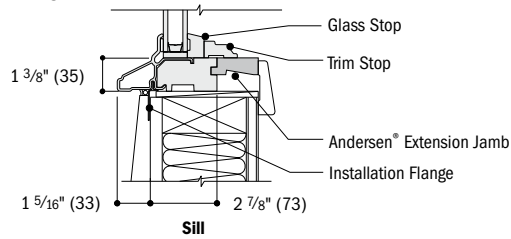

**Vertical Section**

**Combination Designs**

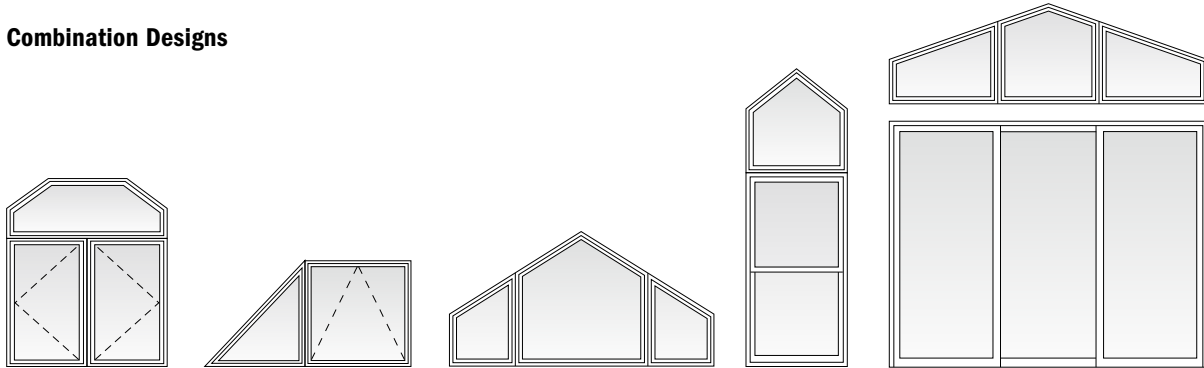

400 Series  
 Specialty Windows

**Extension Jamb Alignment**

For these joined 400 Series window combinations only:

- Arch, Springline™ or Flexiframe over Casement
- Arch, Springline or Flexiframe alongside Awning

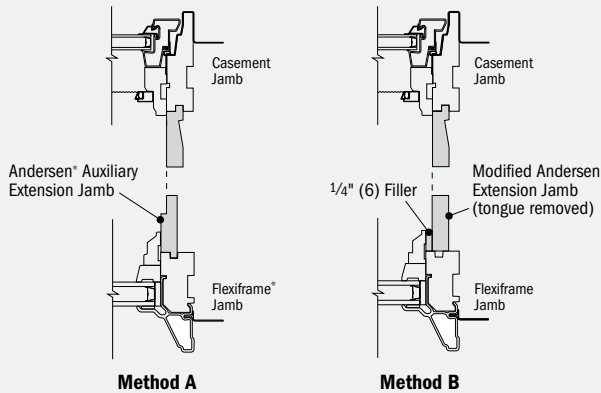

**Method A: Individually Framed** Use optional Andersen auxiliary extension jambs for individual picture frame trimming.

**Method B: Perimeter Framed** For continuous perimeter trimming, remove extension jamb tongue and use 1/4" (6) thick filler between Arch, Springline or Flexiframe trim stop and extension jamb.

**Vertical (ribbon) Joining Detail**

Scale 1 1/2" (38) = 1'-0" (305) – 1:8

**Overall Window Dimension Width**

Sum of individual window widths plus 3/16" (5) for each join.

**Overall Rough Opening Width**

Overall window dimension width plus 1/2" (13).

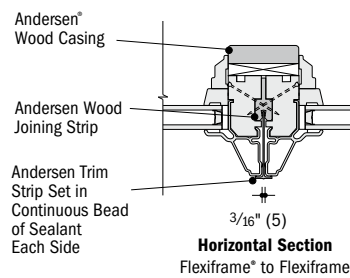

**Horizontal joining on next page.**

**For more joining information, see the combination designs section starting on page 181.**

• Light-colored areas are parts included with window. Dark-colored areas are additional Andersen® parts required to complete window assembly as shown.  
 • Rough openings may need to be increased to allow for use of building wraps, flashing, sill panning, brackets, fasteners or other items. See installation information on pages 210-211.  
 • Details are for illustration only and are not intended to represent product installation methods or materials. Refer to product installation guides at andersenwindows.com.  
 • Dimensions in parentheses are in millimeters.

# SPECIALTY WINDOWS

## Horizontal (stack) Joining Details

Scale 1 1/2" (38) = 1'-0" (305) – 1:8

### Flexiframe® over Flexiframe Window

#### Overall Window Dimension Height

Sum of individual window heights plus 3/16" (5) for each join.

#### Overall Rough Opening Height

Overall window dimension height plus 1/2" (13).

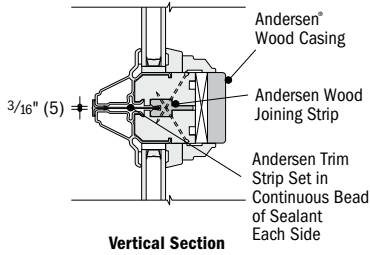

Vertical Section

### Flexiframe over Casement Window

#### Overall Window Dimension Height

Sum of individual window heights plus 3/16" (5) for each join.

#### Overall Rough Opening Height

Overall window dimension height plus 1/2" (13).

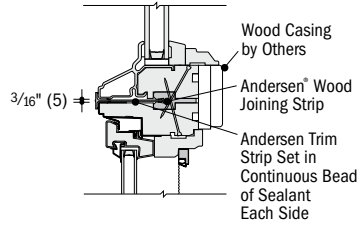

Vertical Section

### Flexiframe over Tilt-Wash Double-Hung Window

#### Overall Window Dimension Height

Sum of individual window heights plus 1/8" (3) for each join.

#### Overall Rough Opening Height

Overall window dimension height plus 1/2" (13).

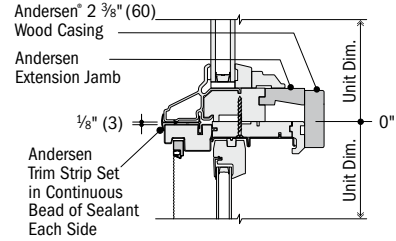

Vertical Section

Vertical joining on previous page.

For more joining information, see the combination designs section starting on page 181.

## Separate Rough Openings Details

Scale 1 1/2" (38) = 1'-0" (305) – 1:8

To meet structural requirements or to achieve a wider joined appearance, windows may be installed into separate rough openings having vertical support (by others) in combination with Andersen® exterior filler and exterior vinyl trim.

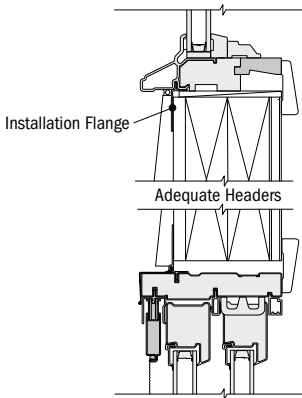

Vertical Section

Flexiframe® and Perma-Shield® Gliding Patio Door

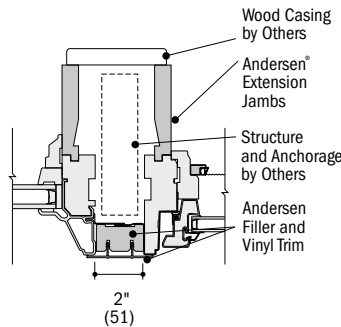

Horizontal Section

Flexiframe® and Awning

\* Light-colored areas are parts included with window. Dark-colored areas are additional Andersen® parts required to complete window assembly as shown.

\* **Rough openings may need to be increased to allow for use of building wraps, flashing, sill panning, brackets, fasteners or other items. See installation information on pages 210-211.**

\* Details are for illustration only and are not intended to represent product installation methods or materials. Refer to product installation guides at andersenwindows.com.

\* Consult with an architect or structural engineer regarding minimum requirements for structural support members between adjacent rough openings.

\* Dimensions in parentheses are in millimeters.

# COMPLEMENTARY SPECIALTY WINDOWS

400 Series  
Complementary  
Specialty Windows

## SECTION REFERENCE

Window Details .....	140
Joining Details.....	140
Combination Designs .....	181
Product Performance.....	194

## CUSTOM SIZING

in 1/8" (3) increments



Dimensions in parentheses are in millimeters.

# COMPLEMENTARY SPECIALTY WINDOWS

## FEATURES

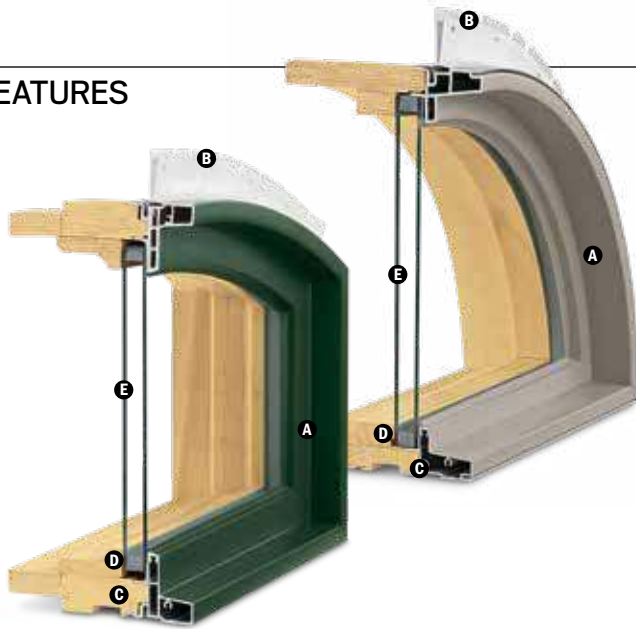

### Frame

**A** Heavy-duty aluminum cladding protects the frame exterior, providing low-maintenance durability. Standard cladding finish meets AAMA 2604 specification. An optional finish that meets the AAMA 2605 specification is also available.

**B** A vinyl installation flange extends 1 1/2" (38) around the perimeter of the unit to help properly position the unit in the opening. Installation clips are standard for increased structural anchoring to building members. Mounted around the frame perimeter, the clips rotate into position and can be bent into place against the framing members to suit all jamb conditions.

**C** Wood members are treated with a water-repellent wood preservative for long-lasting protection and performance. Radii are made of laminated pine veneers. Lineal components are solid or engineered wood with a pine core.

**D** Silicone glazing bead combined with two-sided silicone tape provides superior weathertightness.

### Jamb

A variety of basic unit jamb designs and depths are available to match 400 Series units. Specify desired jamb depth when ordering.

### CAUTION:

- Do not paint weatherstrip.
- Creosote-based stains should not come in contact with Andersen products.
- Abrasive cleaners or solutions containing corrosive solvents should not be used on Andersen products.

\* Visit [andersenwindows.com/warranty](http://andersenwindows.com/warranty) for details. Dimensions in parentheses are in millimeters. Printing limitations prevent exact duplication of colors. See your Andersen supplier for actual color samples.

### Glass

**E** High-Performance glass options include:

- Low-E4® glass
- Low-E4 HeatLock® glass
- Low-E4 Sun glass
- Low-E4 SmartSun™ glass
- Low-E4 SmartSun HeatLock glass

Tempered glass and other glass options are available. Contact your Andersen supplier.

A removable translucent film helps shield the glass from damage during delivery and construction and simplifies finishing at the jobsite.

### Patterned Glass

Patterned glass options are available. See page 12 for more details.



Complementary specialty windows are available with Stormwatch® protection. For more details, visit [andersenwindows.com/coastal](http://andersenwindows.com/coastal).

## EXTERIOR



## INTERIOR

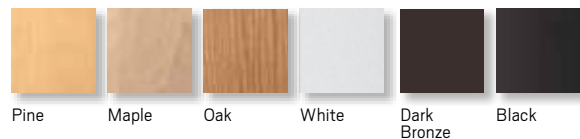

Naturally occurring variations in grain, color and texture of wood make each window one of a kind. All wood interiors are unfinished unless a prefinished option is specified.

## ACCESSORIES Sold Separately

### Frame

#### Extension Jamb

Standard jamb depths are 4 9/16" (116) or 2 7/8" (73). Extension jamba are available in 1/16" (1.5) increments between 4 9/16" (116) and 7 7/8" (181). Additional dimensions are available. Contact your Andersen supplier for more information. Extension jamba are available in unfinished pine or prefinished white, dark bronze or black. Available for jobsite application or can be factory applied.

#### Plinth Blocks

For enhancing casing transitions. Decorated with a radial sunburst or use the reverse side flush face.



For arch windows, use 2 7/8" (73) x 4" (102) size plinth block with 2 1/4" (57) and 2 1/2" (64) casing. Use 3 7/8" (98) x 5 1/4" (133) size with 3 1/2" (89) casing.



For half circle, circle, elliptical and oval windows, use 2 7/8" (73) size plinth block with 2 1/4" (57) and 2 1/2" (64) casing. Use 3 7/8" (98) size with 3 1/2" (89) casing.

### Interior Arch Casing

Available in Colonial or Ranch styles. Additional profiles are also available. For easy integration and consistency, casing dimensions are consistent with Wood Moulding and Millwork Producers Association specifications. Available in pine, oak and maple.



2 1/4" (57) Colonial style. **WM366**



2 1/2" (64) Colonial style. **WM351**



3 1/2" (89) Colonial style. **WM444**



2 1/4" (57) Ranch style. **WM324**  
2 1/2" (64) Ranch style. **WM315**

**Shapes**

Andersen® complementary specialty windows are available in a variety of sizes. Fixed unit profiles may vary dependent upon shape. Contact your Andersen supplier for specific sizes, details and joining information.

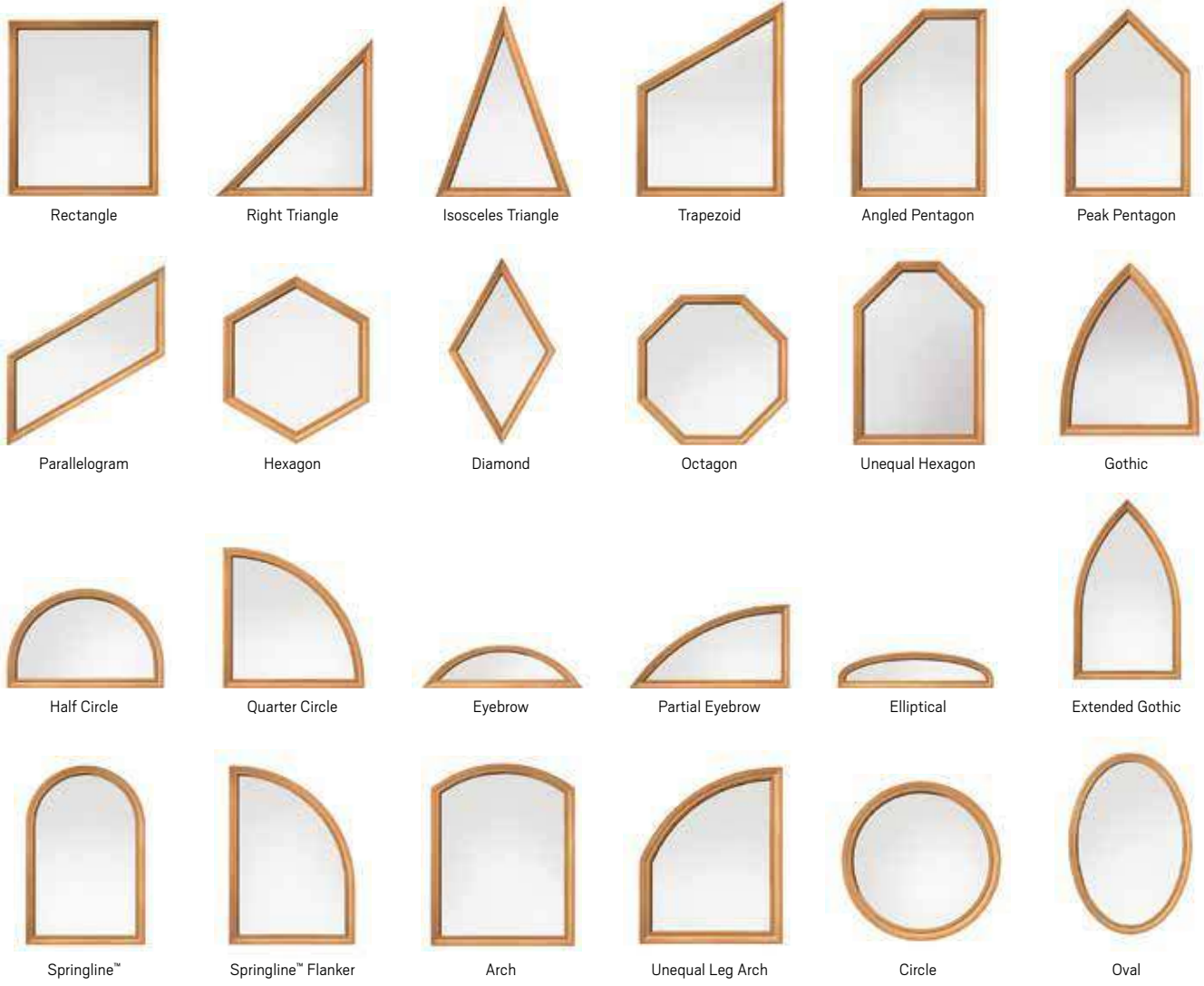

Specialty window shapes below are also available by special order.

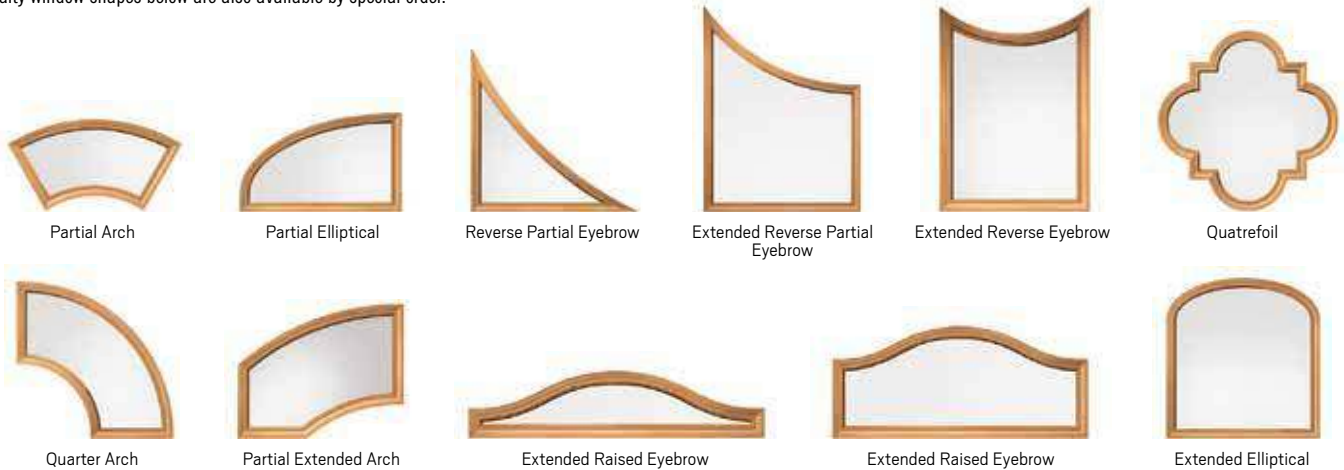

400 Series  
 Complementary  
 Specialty Windows

# COMPLEMENTARY SPECIALTY WINDOWS

## Complementary Specialty Window Details

Scale 1 1/2" (38) = 1'-0" (305) – 1:8

### Complements Casement, Awning and Picture Windows

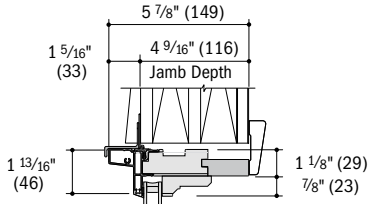

Lineal Head

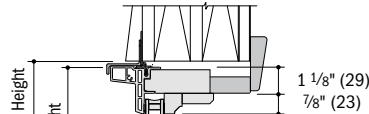

Curved Head

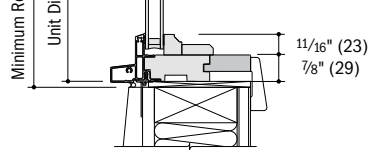

Sill

Vertical Section

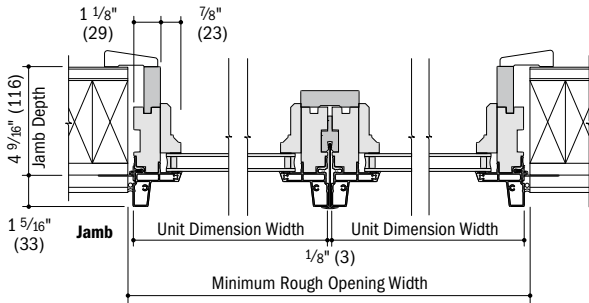

Horizontal Section

### Complements Double-Hung Windows and Patio Doors

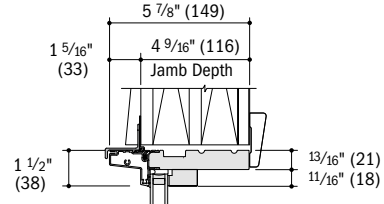

Lineal Head

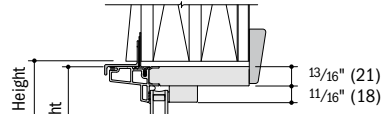

Curved Head

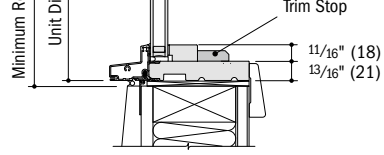

Sill

Vertical Section

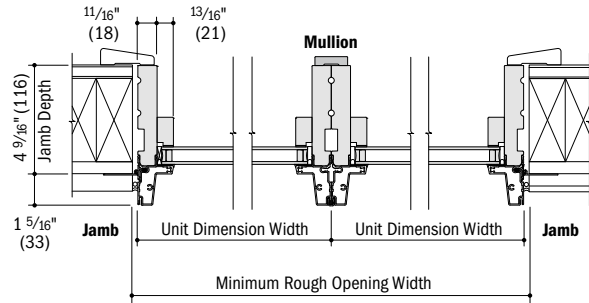

Horizontal Section

## Horizontal (stack) Joining Detail

Scale 1 1/2" (38) = 1'-0" (305) – 1:8

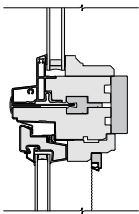

Vertical Section

400 Series Complementary Specialty over  
400 Series Casement Window

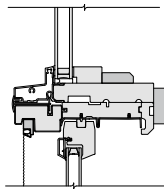

Vertical Section

400 Series Complementary Specialty over  
400 Series Tilt-Wash Double-Hung Window

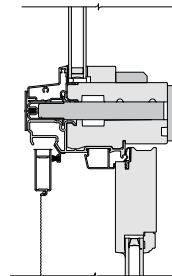

Vertical Section

400 Series Complementary Specialty over  
400 Series Frenchwood® Hinged Inswing Patio Door

For more joining information, see the combination designs section starting on page 181.

- 4 9/16" (116) jamb depth measurement is from back side of installation flange.
- Light-colored areas are parts included with window. Dark-colored areas are additional Andersen® parts required to complete window assembly as shown.
- Rough openings may need to be increased to allow for use of building wraps, flashing, sill panning, brackets, fasteners or other items. See installation information on pages 210-211.
- Details are for illustration only and are not intended to represent product installation methods or materials. Refer to product installation guides at andersenwindows.com.
- Dimensions in parentheses are in millimeters.

# FRENCHWOOD<sup>®</sup> GLIDING PATIO DOORS



400 Series  
Frenchwood<sup>®</sup>  
Gliding Patio Doors

## SECTION REFERENCE

Table of Sizes .....	144
Specifications .....	146
Custom Sizing .....	145
Grille Patterns .....	145
Door Details .....	146-147
Joining Details .....	148
Combination Designs .....	181
Product Performance .....	194

**CUSTOM SIZING**  
in 1/8" (3) increments



Dimensions in parentheses are in millimeters.

# FRENCHWOOD® GLIDING PATIO DOORS

## FEATURES

### Frame

**A** The sill has an extruded aluminum track, with a stainless steel cap that resists stains, rust and denting. A thermal barrier reduces conductive heat loss and limits condensation on the inside. The sill has an attractive wear-resistant, heat-baked finish in a neutral gray color.

**B** All basic exterior frame members are covered with a rigid vinyl sheath that maintains an attractive appearance while minimizing maintenance.

**C** Wood frame members are treated with a water-repellent preservative for long-lasting\* protection and performance. Interior frame trim pieces are unfinished pine. Oak and maple veneer and prefinished white interior options are available.

Factory-assembled two-panel doors are available and arrive at the jobsite ready to install. Unassembled doors are also available and require jobsite assembly.

**D** A flexible vinyl weatherstrip at the head and side jambs provides a positive seal between the frame and panels.

### Panel

**E** The exterior of the wood door panel is protected with a low-maintenance urethane base finish in white, Sandtone, Terratone or forest green.

**F** Panel interior surfaces are unfinished pine veneer. Unfinished oak and maple veneers are available as options. Low-maintenance prefinished white interiors are also available on units with white exteriors.

**G** Dual ball-bearing rollers on door panels provide smooth gliding operation with self-contained leveling adjusters.

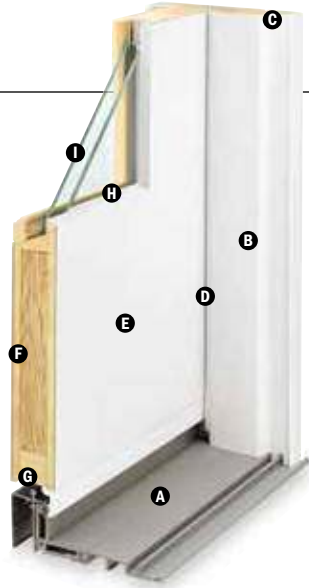

### Mortise-and-Tenon Joints



Panel joints are mortise-and-tenon with patented dowel construction for maximum strength.

### Flexible Seal



A full-length combination weatherstrip/interlock system provides a flexible seal at the meeting stile.

### Glass

**H** Panels are silicone bed glazed and finished with an interior wood stop.

**I** High-Performance glass options include:

- Low-E4® tempered glass
- Low-E4 HeatLock® tempered glass
- Low-E4 Sun tempered glass
- Low-E4 SmartSun™ tempered glass
- Low-E4 SmartSun HeatLock tempered glass

Additional glass options are available. Contact your Andersen supplier.

A removable translucent film helps shield the glass from damage during delivery and construction and simplifies finishing at the jobsite.

### Patterned Glass

Patterned glass options are available. See page 12 for more details.

## EXTERIOR

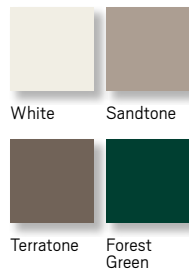

## INTERIOR

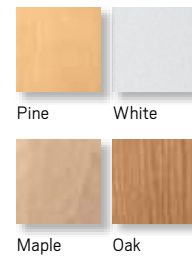

Naturally occurring variations in grain, color and texture of wood make each door one of a kind. All wood interiors are unfinished unless prefinished white is specified.

## HARDWARE FINISHES



Distressed bronze and oil rubbed bronze are "living" finishes that will change with time and use.

## GLIDING PATIO DOOR HARDWARE OPTIONS\*\* Bold name denotes finish shown.



**YUMA®**

Distressed Bronze  
**Distressed Nickel**



**ENCINO®**

Distressed Bronze  
**Distressed Nickel**



**ANVERS®**

Bright Brass  
Oil Rubbed Bronze  
**Satin Nickel**



**NEWBURY®**

Antique Brass  
Bright Brass  
Brushed Chrome  
**Oil Rubbed Bronze**  
Polished Chrome  
Satin Nickel



**COVINGTON™**

Antique Brass  
**Bright Brass**  
Oil Rubbed Bronze



**WHITMORE®**

Antique Brass  
Bright Brass  
Oil Rubbed Bronze  
Satin Nickel



**ALBANY**

Black  
**Gold Dust**  
Stone  
White



**TRIBECA®**

Stone  
**White**

\* Visit [andersenwindows.com/warranty](http://andersenwindows.com/warranty) for details.

\*\* Hardware sold separately.

Printing limitations prevent exact replication of colors and finishes. See your Andersen supplier for actual color and finish samples.

Tribeca and Albany hardware are zinc die cast with powder-coated durable finish. Other hardware is solid forged brass. Mix-and-match interior and exterior style and finish options are available. Bright brass and satin nickel finishes feature a 10-year limited warranty.

## Locking System

### Reachout Locking Hardware



The unique Andersen® reachout locking hardware pulls the door panel snugly into the jamb for a weathertight seal and enhanced security.

### Blinds-Between-the-Glass



Blinds-between-the-glass are available for select gliding patio door sizes when ordered with Low-E4® tempered glass and a pine or prefinished white door interior and any of our four exterior insect colors. White 1/2" (13) aluminum slat blinds come mounted between two panes of insulated glass in a dust-free environment. Blinds are magnetically controlled and can be tilted, raised and lowered using low profile controls. Smooth, simple operation allows for customized light and privacy control. Available in 3368, 33611, 6068, 60611, 12068-4, 120611-4 door sizes.

For more information about **glass, patterned glass, art glass and grilles**, see pages 12-14.

For more information about **combination designs, product performance, installation instructions and accessories**, see pages 181-211 or visit [andersenwindows.com](http://andersenwindows.com).

## ACCESSORIES Sold Separately

### Frame

#### Extension Jamb

Standard jamb depth is 4 9/16" (116). Pine, oak or maple veneer or prefinished white interior extension jambs are available in 1/16" (1.5) increments between 5 1/16" (129) and 7 1/8" (181).

#### Threshold



An oak or maple threshold is available for finishing the interior of the sill.

#### Ramped Sill Insert



Ramped sills in oak or maple provide smooth transition from interior to exterior and can be used with a retractable insect screen but not a gliding insect screen. Check with local and federal officials to determine if product meets accessibility codes.

#### Sill Support



An aluminum sill support is designed to lock into a channel under the sill and tie back into the wall. This will offer support to the outermost sill section when needed. Available in neutral gray finish.

### Hardware

#### Exterior Keyed Lock



A six-pin key cylinder lock is available in finishes that coordinate with hardware. This lock allows the gliding door to be locked and unlocked from the exterior.

### Auxiliary Foot Lock



Provides an extra measure of security when the door is in a locked position. Lock can be set so the door is fully closed or partially open to provide a secure venting position. Available in all hardware finishes.

### Insect Screens

All insect screens have a long-lasting\* fiberglass screen mesh with a charcoal finish, and frames are color matched to the exterior of the door unless otherwise specified.

#### Gliding Insect Screen

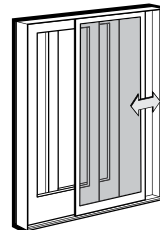

Patented square-corner joint construction adds considerable strength to the frame members. The insect screen is available for both two-panel doors and four-panel doors. Gliding insect screens have Delrin® injection-molded bottom rollers with self-contained leveling adjusters, providing smooth operation. Interior and exterior pulls and latch are provided.

#### Retractable Insect Screen

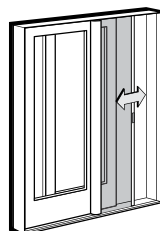

The retractable insect screen is installed on the exterior of the door and opens side to side across the width of the opening. When the insect screen is not in use, it neatly retracts into a small canister mounted on the exterior of the door. The retractable insect screen canister is available for two-panel patio doors in our four standard exterior colors. Please note, retractable insect screen track reduces clear opening height by 1" (25).

### Security Sensors

#### VeriLock® Sensors

VeriLock sensors are available in five colors. See page 15 for details.

#### Open/Closed Sensors

Wireless open/closed sensors are available in four colors. See page 15 for details.

### Glass

#### Andersen Art Glass

Andersen art glass panels come in a variety of original patterns. Available for stationary panels, sidelights and transoms. See pages 173-174 for details on Andersen art glass. Visit [andersenwindows.com/artglass](http://andersenwindows.com/artglass) for details and pattern information.

### Grilles

Grilles are available in a variety of configurations and widths. For patio door grille patterns, see page 145.

### Sidelights & Transoms

Andersen Frenchwood® patio door sidelights and transoms feature elegant lines that match our Frenchwood gliding patio doors. They feature pine, oak, maple or prefinished white interior options, plus our four standard exterior colors. Stationary units can also be selected for use as sidelights. See pages 159-162 for details.

### Exterior Trim

This product is available with Andersen exterior trim. See pages 175-180 for details.

#### CAUTION:

- Painting and staining may cause damage to rigid vinyl.
- Do not paint 400 Series patio doors with white, canvas, Sandtone, forest green, dark bronze or black exterior colors.
- Andersen does not warrant the adhesion or performance of homeowner-applied paint over vinyl or other factory-coated surfaces.
- 400 Series patio doors in Terratone color may be painted any color lighter than Terratone color using quality oil-based or latex paint.
- For vinyl painting instructions and preparation, contact your Andersen supplier.
- Do not paint weatherstrip.
- Creosote-based stains should not come in contact with Andersen products.
- Abrasive cleaners or solutions containing corrosive solvents should not be used on Andersen products.

\* Visit [andersenwindows.com/warranty](http://andersenwindows.com/warranty) for details.

Andersen patio doors are not intended for use as entrance doors.

Dimensions in parentheses are in millimeters.

"Delrin" is a registered trademark of E. I. du Pont de Nemours and Company.

# FRENCHWOOD® GLIDING PATIO DOORS

## Three Patio Door Heights

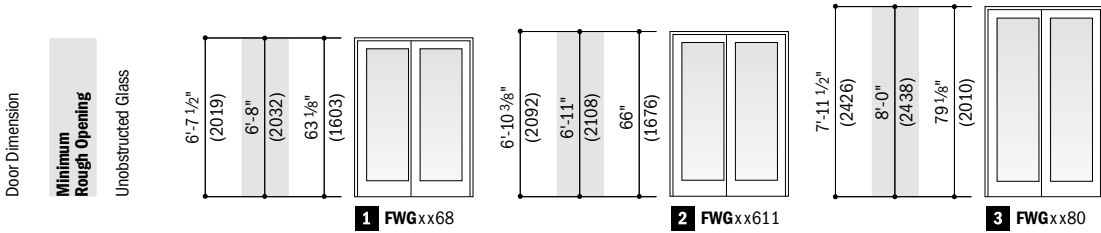

For all four-panel gliding patio doors, add 1/4" (6) to the "Minimum Rough Opening" height dimension.

## Table of Frenchwood® Gliding Patio Door Sizes

Scale 1/8" (3) = 1'-0" (305) – 1:96

Door Dimension	2'-8"	4'-11 1/4"	4'-11 1/4"	9'-9"
	(813)	(1505)	(1505)	(2972)
<b>Minimum Rough Opening</b>	2'-8 3/4"	5'-0"	5'-0"	9'-9 3/4"
	(832)	(1524)	(1524)	(2991)
Unobstructed Glass (single panel only)	21 1/8"	21 1/8"	21 1/8"	21 1/8"
	(537)	(537)	(537)	(537)

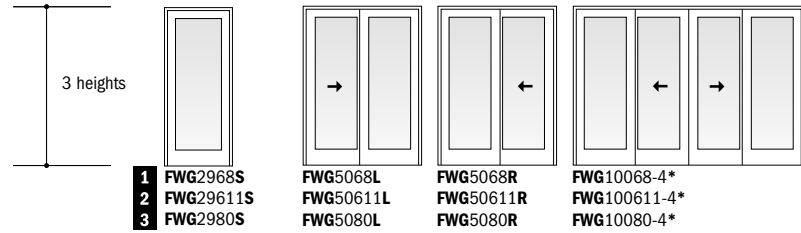

Door Dimension	3'-2"	5'-11 1/4"	5'-11 1/4"	11'-9"
	(965)	(1810)	(1810)	(3581)
<b>Minimum Rough Opening</b>	3'-2 3/4"	6'-0"	6'-0"	11'-9 3/4"
	(984)	(1829)	(1829)	(3600)
Unobstructed Glass (single panel only)	27 1/8"	27 1/8"	27 1/8"	27 1/8"
	(689)	(689)	(689)	(689)

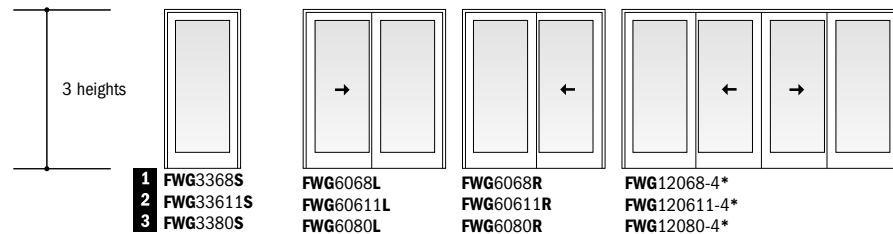

Door Dimension	4'-2"	7'-11 1/4"	7'-11 1/4"	15'-9"
	(1270)	(2419)	(2419)	(4801)
<b>Minimum Rough Opening</b>	4'-2 3/4"	8'-0"	8'-0"	15'-9 3/4"
	(1289)	(2438)	(2438)	(4820)
Unobstructed Glass (single panel only)	39 1/8"	39 1/8"	39 1/8"	39 1/8"
	(994)	(994)	(994)	(994)

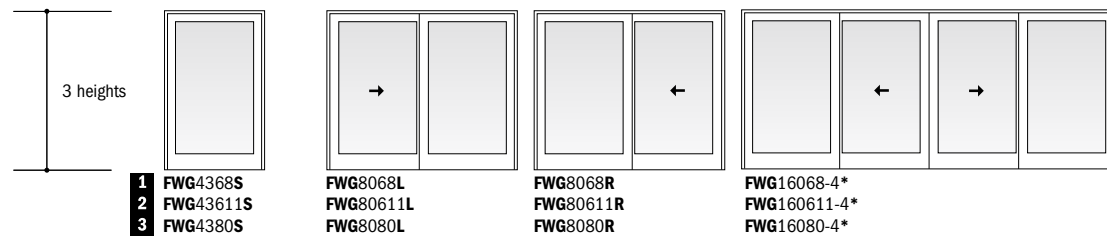

Custom-size doors are available in 1/8" (3) increments. See page 145 for custom sizes and specifications.

Viewed from the exterior. Arrow indicates direction of panel operation. Stationary (S) doors can be used as an individual unit or as a sidelight. Two-panel doors are available factory assembled and arrive at the jobsite ready to install.

Grille patterns shown on page 145.

\*"Door Dimension" always refers to outside frame to frame dimension.  
 \*"Minimum Rough Opening" dimensions may need to be increased to allow for use of building wraps, flashing, sill panning, brackets, fasteners or other items. See pages 210-211 for more details.  
 \*Dimensions in parentheses are in millimeters.  
 \*Add 1/4" (6) to the "Minimum Rough Opening" height dimension for four-panel doors.

**Order Designation Description**

Viewed from the exterior.

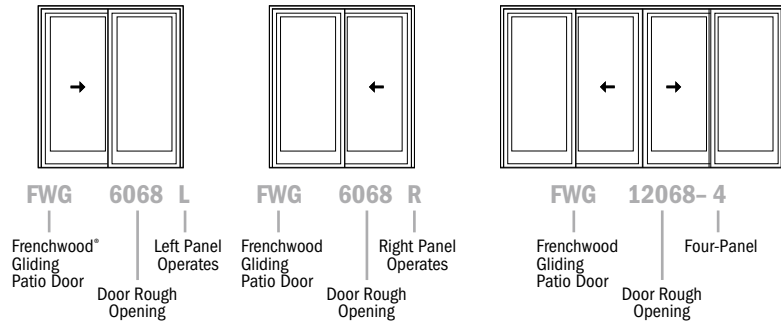

**Custom Sizes and Specification Formulas**

Measurement guide for custom-size patio doors can be found at [andersenwindows.com/measure](http://andersenwindows.com/measure).

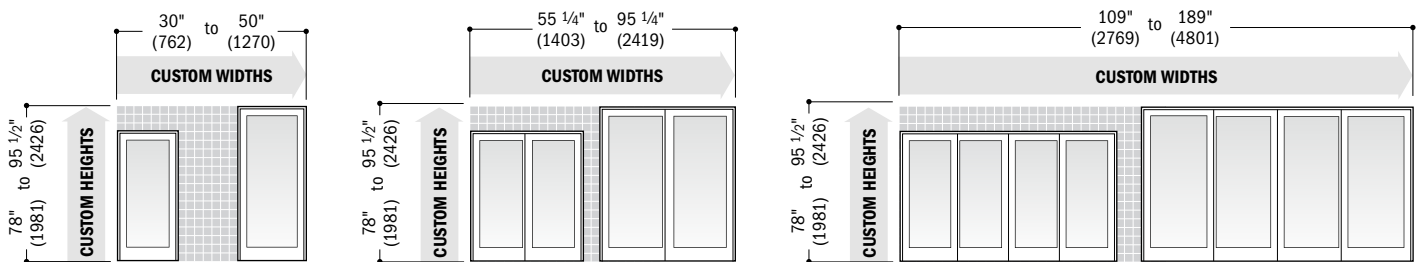

Clear Opening	Two-Panel	Minimum R.O.	Single-Panel & Two-Panel	Unobstr. Glass	Single-Panel
	$Width = (width + 2) - 7.773" (197)$ $Height = height - 4.155" (106)$		$Width = width + 3/4" (19)$ $Height = height + 1/2" (13)$		$Width = width - 10.876" (276)$ $Height = height - 16.391" (416)$
	$Width = (width + 2) - 14.322" (364)$ $Height = height - 4.155" (106)$		$Width = width + 3/4" (19)$ $Height = height + 3/4" (19)$		$Width = width - 17.002" (432)$ $Height = height - 16.391" (416)$
	$Width = (width + 2) - 14.322" (364)$ $Height = height - 4.155" (106)$		$Width = width + 3/4" (19)$ $Height = height + 3/4" (19)$		$Width = width - 32.504" (826)$ $Height = height - 16.391" (416)$



Available in 1/8" (3) increments between minimum and maximum widths and heights shown. Some restrictions apply.

\* Dimensions in parentheses are in millimeters.  
 • **Clear Opening** formulas provide dimensions for determining area available for egress. Vent opening, or area available for passage of air, is equal to clear opening. **Minimum R.O.** (minimum rough opening) formulas provide minimum rough opening width and height dimensions. **Unobstr. Glass** (unobstructed glass) formulas provide dimensions for determining area available for passage of light.

**Grille Patterns**

	Prairie A	Colonial	Modified Colonial	Modified Colonial with Simulated Meeting Rail	Tall Fractional	Tall Fractional with Simulated Meeting Rail	Short Fractional	Short Fractional with Simulated Meeting Rail
<b>Frenchwood® Gliding Patio Doors</b>								

**Number of lights and overall pattern varies with panel size.**  
**Patterns are not available in all configurations.** Specified equal light and custom patterns are also available. For more grille options, see page 13 or visit [andersenwindows.com/grilles](http://andersenwindows.com/grilles).

400 Series  
Frenchwood®  
Gliding Patio Doors

# FRENCHWOOD® GLIDING PATIO DOORS

## Two-Panel & Four-Panel Frenchwood® Gliding Patio Door Opening and Area Specifications

Door Number	Clear Opening Area Sq. Ft./ (m <sup>2</sup> )	Clear Opening in Full Open Position		Glass Area Sq. Ft./ (m <sup>2</sup> )	Vent Area Sq. Ft./ (m <sup>2</sup> )	Overall Door Area Sq. Ft./ (m <sup>2</sup> )
		Width Inches/(mm)	Height Inches/(mm)			
FWG5068	11.58 (1.08)	22 1/8" (562)	75 3/8" (1915)	18.52 (1.72)	11.58 (1.08)	32.71 (3.04)
FWG6068	14.72 (1.37)	28 1/8" (714)	75 3/8" (1915)	23.78 (2.21)	14.72 (1.37)	39.34 (3.66)
FWG8068	21.00 (1.95)	40 1/8" (1019)	75 3/8" (1915)	34.30 (3.19)	21.00 (1.95)	52.59 (4.89)
FWG10068	23.42 (2.18)	44 3/4" (1137)	75 3/8" (1915)	37.04 (3.44)	23.42 (2.18)	64.59 (6.00)
FWG12068	29.70 (2.76)	56 3/4" (1441)	75 3/8" (1915)	47.55 (4.42)	29.70 (2.76)	77.84 (7.23)
FWG16068	42.27 (3.93)	80 3/4" (2051)	75 3/8" (1915)	68.60 (6.37)	42.27 (3.93)	104.34 (9.69)
FWG50611	12.04 (1.12)	22 1/8" (562)	78 3/16" (1987)	19.36 (1.80)	12.04 (1.12)	33.89 (3.15)
FWG60611	15.31 (1.42)	28 1/8" (714)	78 3/16" (1987)	24.86 (2.31)	15.31 (1.42)	40.76 (3.79)
FWG80611	21.84 (2.03)	40 1/8" (1019)	78 3/16" (1987)	35.85 (3.33)	21.84 (2.03)	54.49 (5.06)
FWG100611	24.36 (2.26)	44 3/4" (1137)	78 3/16" (1987)	38.72 (3.60)	24.36 (2.26)	66.93 (6.22)
FWG120611	30.89 (2.87)	56 3/4" (1441)	78 3/16" (1987)	49.71 (4.62)	30.89 (2.87)	80.66 (7.49)
FWG160611	43.95 (4.08)	80 3/4" (2051)	78 3/16" (1987)	71.71 (6.66)	43.95 (4.08)	108.12 (10.04)
FWG5080	14.04 (1.30)	22 1/8" (562)	91 3/8" (2321)	23.20 (2.16)	14.04 (1.30)	39.29 (3.65)
FWG6080	17.85 (1.66)	28 1/8" (714)	91 3/8" (2321)	29.80 (2.77)	17.85 (1.66)	47.25 (4.39)
FWG8080	25.46 (2.37)	40 1/8" (1019)	91 3/8" (2321)	42.98 (3.99)	25.46 (2.37)	63.17 (5.87)
FWG10080	28.40 (2.64)	44 3/4" (1137)	91 3/8" (2321)	46.40 (4.31)	28.40 (2.64)	77.59 (7.21)
FWG12080	36.01 (3.35)	56 3/4" (1441)	91 3/8" (2321)	59.60 (5.54)	36.01 (3.35)	93.51 (8.69)
FWG16080	51.24 (4.76)	80 3/4" (2051)	91 3/8" (2321)	85.96 (7.99)	51.24 (4.76)	125.34 (11.64)

\*Dimensions in parentheses are in millimeters or square meters

## Stationary Frenchwood Gliding Patio Door Area Specifications

Door Number	Glass Area Sq. Ft./ (m <sup>2</sup> )	Overall Door Area Sq. Ft./ (m <sup>2</sup> )
FWG2968	9.26 (0.86)	17.67 (1.64)
FWG3368	11.89 (1.11)	20.98 (1.95)
FWG4368	17.15 (1.59)	27.60 (2.56)
FWG29611	9.68 (0.90)	18.31 (1.70)
FWG33611	12.43 (1.16)	21.74 (2.02)
FWG43611	17.93 (1.67)	28.60 (2.66)
FWG2980	11.60 (1.08)	21.22 (1.97)
FWG3380	14.90 (1.38)	25.20 (2.34)
FWG4380	21.49 (2.00)	33.16 (3.08)

\*Dimensions in parentheses are in square meters

## Frenchwood® Gliding Patio Door Details

Scale 1 1/2" (38) = 1'-0" (305) – 1:8

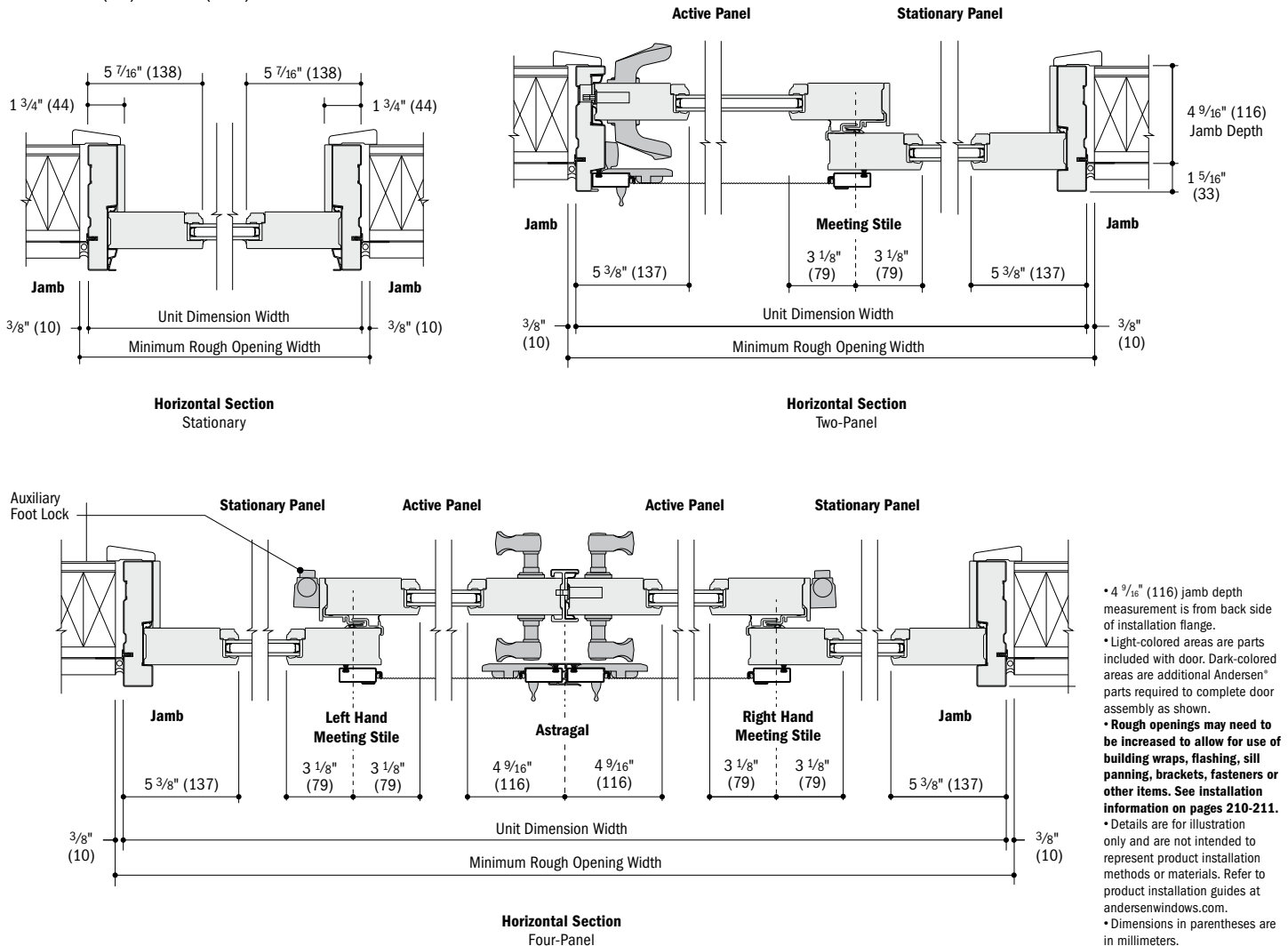

**Frenchwood® Gliding Patio Door Details**

Scale 1 1/2" (38) = 1'-0" (305) – 1:8

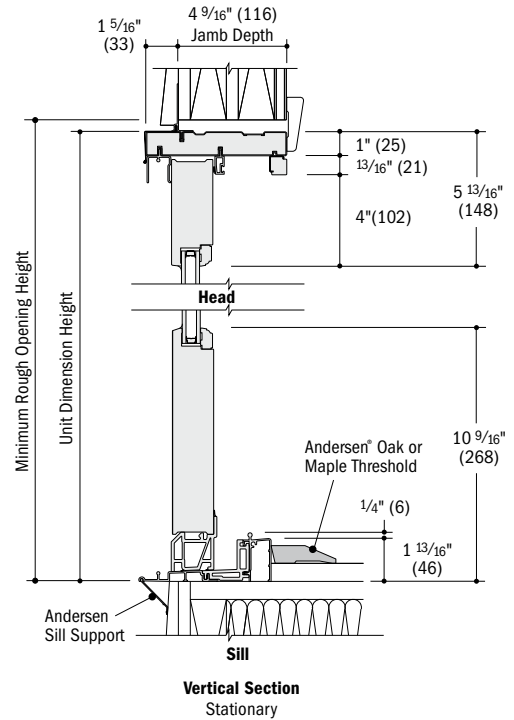
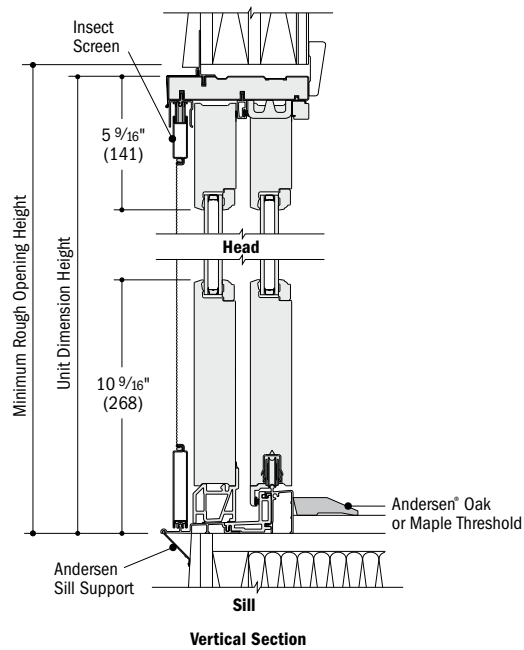

**Clear Opening Details**

Scale 1 1/2" (38) = 1'-0" (305) – 1:8

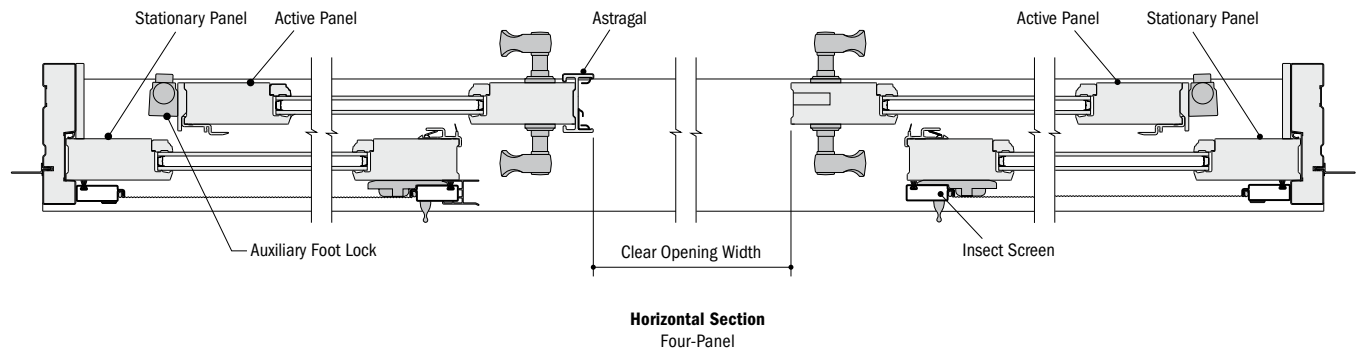
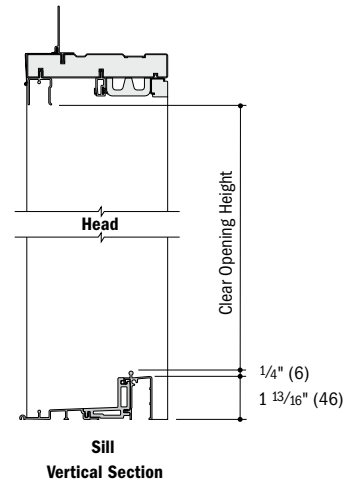
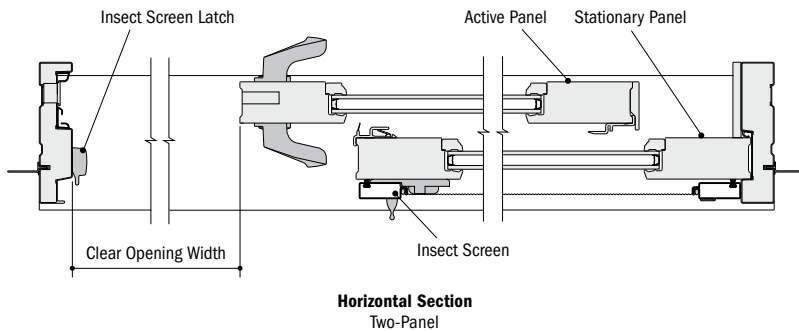

- 4 9/16" (116) jamb depth measurement is from back side of installation flange.
- Light-colored areas are parts included with door. Dark-colored areas are additional Andersen® parts required to complete door assembly as shown.
- **Rough openings may need to be increased to allow for use of building wraps, flashing, sill panning, brackets, fasteners or other items. See installation information on pages 210-211.**
- Details are for illustration only and are not intended to represent product installation methods or materials. Refer to product installation guides at andersenwindows.com.
- Dimensions in parentheses are in millimeters.

400 Series  
Frenchwood®  
Gliding Patio Doors

# FRENCHWOOD® GLIDING PATIO DOORS

## Ramped Sill Detail

Scale 1 1/2" (38) = 1'-0" (305) – 1:8

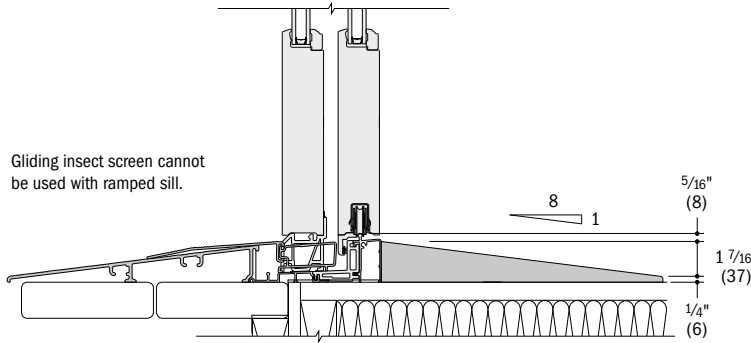

Vertical Section

## Vertical Joining Detail

Scale 1 1/2" (38) = 1'-0" (305) – 1:8

### Overall Door Dimension Width

Sum of individual door widths plus 1/16" (1.5) for each join.

### Overall Rough Opening Width

Overall door width plus 3/4" (19).

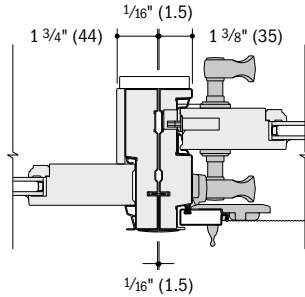

Horizontal Section

Frenchwood® Gliding to Frenchwood Gliding

## Vertical Joining Detail - LVL

Scale 1 1/2" (38) = 1'-0" (305) – 1:8

### Overall Door Dimension Width

Sum of individual door widths plus 3/4" (19) for each join.

### Overall Rough Opening Width

Overall door width plus 3/4" (19).

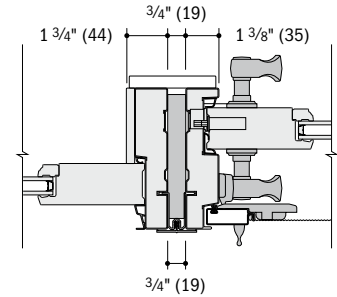

Horizontal Section

Frenchwood Gliding to Frenchwood Gliding

Andersen does not recommend joining of receiver jamb to receiver jamb. For more joining information, see the combination designs section starting on page 181.

## Separate Rough Openings Detail

Scale 1 1/2" (38) = 1'-0" (305) – 1:8

To meet structural requirements or to achieve a wider joined appearance, doors may be installed into separate rough openings having vertical support (by others) in combination with Andersen® exterior filler and exterior vinyl trim.

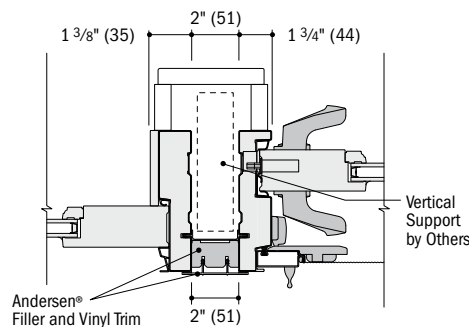

Horizontal Section

Frenchwood Gliding and Frenchwood Gliding

\* Light-colored areas are parts included with door. Dark-colored areas are additional Andersen® parts required to complete door assembly as shown.

\* **Rough openings may need to be increased to allow for use of building wraps, flashing, sill panning, brackets, fasteners or other items. See installation information on pages 210-211.**

\* Details are for illustration only and are not intended to represent product installation methods or materials. Refer to product installation guides at andersenwindows.com.

\* Andersen recommends installation of doors into separate rough openings. Consult with an architect or structural engineer regarding minimum requirements for structural support members between adjacent rough openings.

\* Dimensions in parentheses are in millimeters.

# FRENCHWOOD<sup>®</sup> HINGED IN SWING PATIO DOORS



400 Series  
Frenchwood<sup>®</sup> Hinged  
Inswing Patio Doors

## SECTION REFERENCE

Table of Sizes .....	152-153
Specifications .....	154
Custom Sizing .....	155
Grille Patterns .....	155
Door Details .....	156-157
Joining Details .....	158
Combination Designs .....	181
Product Performance .....	194

**CUSTOM SIZING**  
in 1/8" (3) increments



Dimensions in parentheses are in millimeters.

# FRENCHWOOD® HINGED INSWING PATIO DOORS

## FEATURES

### Frame

**A** The sill is made with three-piece construction. The subsill is made of Fibrex® material, and the sill step is solid oak. The exterior sill member is made of extruded aluminum with an attractive wear-resistant, heat-baked finish in a neutral color. This combination of materials combines durability and low maintenance with excellent insulating characteristics.

**B** All basic exterior frame members are fiberglass reinforced composite, which maintains an attractive appearance while minimizing maintenance.

**C** The exterior frame members are attached to a water-repellent preservative-treated wood subframe for long-lasting\* protection and performance. The subframe is grooved to accept extension jams.

### Panel

**D** The exterior of the wood door panel is protected with a long-lasting\*\* urethane base finish in white, Sandtone, Terratone or forest green.

**E** Panel interior surfaces are unfinished pine veneer. Unfinished oak and maple veneers are available as options. Low-maintenance prefinished white interiors are also available.

Hinged inswing operating panels are left-hand active, right-hand active or two-panel active-passive jamb hinged.

**F** A factory-applied, one-piece compression-type rubber weatherstrip continues in one plane around the panel to provide maximum effectiveness against water and air infiltration. The corners of the weatherstrip are welded to eliminate gaps between the panel and the frame/sill shoulder.

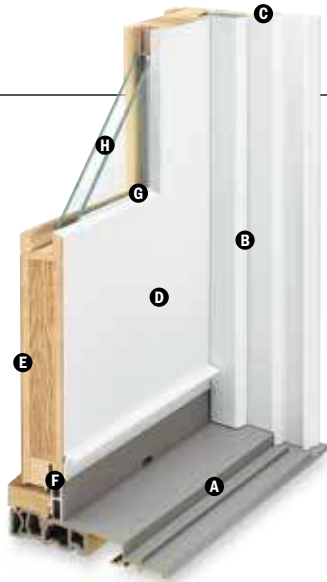

### Mortise-and-Tenon Joints



Mortise-and-tenon joints prevent panel sag and maintain smooth operation.

### Adjustable Hinges

Adjustable hinges are standard on inswing patio doors and have ball-bearing pivots for smooth, frictionless movement. Features easy horizontal and vertical adjustment, plus quick-release feature for easy panel removal. This release feature is ideal for transporting large units up stairs or to other hard-to-reach areas.



Shown in gold dust finish.

Gold dust finish is standard on wood interior doors. For units with prefinished white interior, white is standard. Also available in finishes that coordinate with hardware.

### Glass

**G** Panels are silicone bed glazed and finished with an interior wood stop.

**H** High-performance glass options include: Low-E4® tempered, Low-E4 HeatLock® tempered, Low-E4 Sun tempered, Low-E4 SmartSun™ tempered and Low-E4 SmartSun HeatLock tempered glass.

Additional glass options are available. Contact your Andersen supplier.

A removable translucent film helps shield the glass from damage during delivery and construction and simplifies finishing at the jobsite.

### Patterned Glass

Patterned glass options are available. See page 12 for more details.

### Hardware

#### Multi-Point Locking System



The multi-point locking system, with a hook bolt above and below the center dead bolt, provides a weathertight seal and enhanced security.

## EXTERIOR

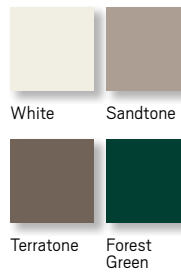

## INTERIOR

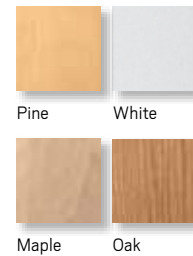

Prefinished white interiors are only available on units with white exteriors. Naturally occurring variations in grain, color and texture of wood make each door one of a kind. All wood interiors are unfinished unless prefinished white is specified.

## HARDWARE FINISHES

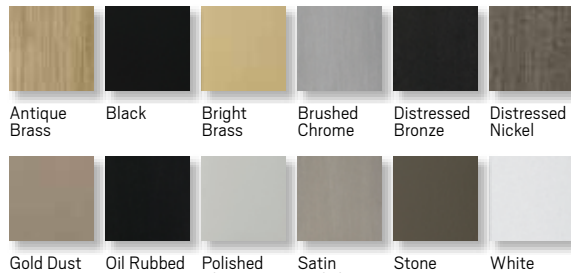

Distressed bronze and oil rubbed bronze are "living" finishes that will change with time and use.

## HINGED PATIO DOOR HARDWARE OPTIONS\*\*



\* Visit andersenwindows.com/warranty for details.

\*\* Hardware sold separately.

Dimensions in parentheses are in millimeters.

"FSB" is a registered trademark of Franz Schneider Brakel GmbH & Co.

Mix-and-match interior and exterior style and finish options are available.

Bright brass and satin nickel finishes feature a 10-year limited warranty.

Tribeca and Albany hardware are zinc die cast with powder-coated durable finish. Other hardware is solid forged brass.

Printing limitations prevent exact replication of colors and finishes. See your Andersen supplier for actual color and finish samples.

**Blinds-Between-the-Glass**



Blinds-between-the-glass are available for select hinged patio door sizes when ordered with Low-E4® tempered glass and a pine or prefinished white door interior and any of our four exterior colors. White 1/2" (13) aluminum slat blinds come mounted between two panes of insulated glass in a dust-free environment. Blinds are magnetically controlled and can be tilted, raised and lowered using low profile controls. Smooth, simple operation allows for customized light and privacy control. Available in 2768, 27611, 3168, 31611, 5068, 50611, 6068, 60611, 9068, 90611 door sizes.

**CAUTION:**

- Painting and staining may cause damage to rigid vinyl.
- Do not paint 400 Series patio doors with white, canvas, Sandtone, forest green, dark bronze or black exterior colors.
- Andersen does not warrant the adhesion or performance of homeowner-applied paint over vinyl or other factory-coated surfaces.
- 400 Series patio doors in Terratone color may be painted any color lighter than Terratone color using quality oil-based or latex paint.
- For vinyl painting instructions and preparation, contact your Andersen supplier.
- Do not paint weatherstrip.
- Creosote-based stains should not come in contact with Andersen products.
- Abrasive cleaners or solutions containing corrosive solvents should not be used on Andersen products.

\* Exterior extension jambs for hinged inswing patio doors must be applied before installing into opening.

\*\* Visit [andersenwindows.com/warranty](http://andersenwindows.com/warranty) for details.

Andersen patio doors are not intended for use as entrance doors.

Dimensions in parentheses are in millimeters.

"Delrin" is a registered trademark of E.I. du Pont de Nemours and Company.

For more information about **glass, patterned glass, art glass and grilles**, see pages 12-14.

For more information about **combination designs, product performance, installation instructions and accessories**, see pages 181-211 or visit [andersenwindows.com](http://andersenwindows.com).

**ACCESSORIES** Sold Separately

**Frame**

**Interior Extension Jambs**

Standard jamb depth is 4 9/16" (116). Pine, oak or maple veneer or prefinished white extension jambs are available in 1/16" (1.5) increments between 5 1/16" (129) and 7 1/8" (181). Interior extension jambs on inswing units will restrict the full opening of door.

**Exterior Extension Jambs\***

Exterior extension jamb system is available for the following wall thicknesses: 5 1/4" (133), 6 9/16" (167) and 7 9/16" (192). In walls over 4 1/2" (114), the exterior sill extender and exterior extension jamb system allow the unit to be installed flush to the interior, so the hinged doors will open flat against the interior wall. Colored-matched to the exterior of the finished unit, this system provides a low-maintenance, finished exterior appearance. An extended double-insect screen track is available for jamb-hinged doors that require gliding insect screens. Exterior extension jamb kits are available with or without the double-insect screen track.

**Threshold**



An oak or maple threshold is available for finishing the interior of the sill.

**Sill Support**



An aluminum sill support is designed to lock into a channel under the sill and tie back into the wall. This will offer support to the outermost sill section when needed. Available in neutral gray finish.

**Ramped Sill Insert**



Ramped sills provide smooth transition from interior to exterior. Shown with a Frenchwood® gliding patio door. It cannot be used with hinged or gliding insect screens. Check with local and federal officials to determine if product meets accessibility codes.

**Hardware**

**Exterior Keyed Lock**



A six-pin key cylinder lock is available in styles and finishes that coordinate with hardware. This lock allows the hinged patio door to be locked and unlocked from the exterior.

**Handle Extension**



Extends interior door handle an additional 1" (25) from the door interior panel to accommodate blinds or shades. Kit includes one handle extender and spindle. A second extender may be added to increase the length an additional 1" (25) to a 2" (51) total extension. Extenders are available in finishes that coordinate with hardware.

**Strike Plate Extensions**

Bright brass, antique brass, polished chrome, oil rubbed bronze, brushed chrome and satin nickel strike plate extensions are available for the following wall thicknesses: 5 1/4" (133), 6 9/16" (167), 7 1/8" (181) and 7 9/16" (192).

**Construction Lock**



This hardware can be used on all Andersen® hinged doors to help secure the structure during the construction phase of the project. It features an undersized escutcheon plate, which makes on-site finishing easier.

**Panel Stop**



This hinged door panel stop helps prevent wall damage when opening the inswing door. Available in finishes that coordinate with hardware.

**Grilles**

Grilles are available in a variety of configurations and widths. For patio door grille patterns, see page 155.

**Insect Screens**

All insect screens have a long-lasting\*\* fiberglass screen mesh with a charcoal finish and frames are color matched to the exterior of the door unless otherwise specified.

**Gliding Insect Screen**

Available for all two- and three-panel doors. Features Delrin® material injection molded bottom rollers with self-contained leveling adjusters. A double-insect screen track is required for two-panel active-passive or passive-active doors. Gliding insect screens are not available for 4' (1219) wide doors. Insect screens are shown on page 14.

**Double-Insect Screen Track**



An extended insect screen track is required for two-panel active-passive or passive-active hinged doors that use gliding insect screens.

**Hinged Insect Screens**

Available for single-panel hinged doors and two-panel active-passive or passive-active doors. Insect screens are shown on page 14.

**Security Sensors**

**VeriLock® Sensors**

VeriLock sensors are available in five colors. See page 15 for details.

**Open/Closed Sensors**

Wireless open/closed sensors are available in four colors. See page 15 for details.

**Glass**

**Andersen Art Glass**

Andersen art glass panels come in a variety of original patterns. See pages 173-174 for details on Andersen art glass. Visit [andersenwindows.com/artglass](http://andersenwindows.com/artglass) for details and pattern information.

**Sidelights & Transoms**

Andersen Frenchwood patio door sidelights and transoms feature elegant lines that match our Frenchwood hinged patio doors. See pages 159-162 for details.

**Exterior Trim**

This product is available with Andersen exterior trim. See pages 175-180 for details.

# FRENCHWOOD® HINGED INSWING PATIO DOORS

**Table of Frenchwood® Hinged Inswing Patio Door Sizes**

Scale 1/8" (3) = 1'-0" (305) – 1:96

Door Dimension	2'-0 1/2" (620)			4'-0" (1219)		4'-0" (1219)			
<b>Minimum Rough Opening</b>	2'-1" (634)			4'-1" (1242)		4'-1" (1242)			
Unobstructed Glass (single panel only)	13 1/4" (336)			13 1/4" (336)		13 1/4" (336)			
3 heights									
	<ol style="list-style-type: none"> <li>1 FWH2168S</li> <li>2 FWH21611S</li> <li>3 FWH2180S</li> </ol>			<ol style="list-style-type: none"> <li>1 FWH4168APLR</li> <li>2 FWH41611APLR</li> <li>3 FWH4180APLR</li> </ol>		<ol style="list-style-type: none"> <li>1 FWH4168PALR</li> <li>2 FWH41611PALR</li> <li>3 FWH4180PALR</li> </ol>			
Door Dimension	2'-6 1/8" (765)	2'-6 1/8" (765)	2'-6 1/8" (765)	4'-11 1/4" (1504)	4'-11 1/4" (1504)	4'-11 1/4" (1504)	4'-11 1/4" (1504)	4'-11 1/4" (1504)	
<b>Minimum Rough Opening</b>	2'-7" (787)	2'-7" (787)	2'-7" (787)	5'-0" (1524)	5'-0" (1524)	5'-0" (1524)	5'-0" (1524)	5'-0" (1524)	
Unobstructed Glass (single panel only)	18 7/8" (479)	18 7/8" (479)	18 7/8" (479)	18 7/8" (479)	18 7/8" (479)	18 7/8" (479)	18 7/8" (479)	18 7/8" (479)	
3 heights									
	<ol style="list-style-type: none"> <li>1 FWH2768S</li> <li>2 FWH27611S</li> <li>3 FWH2780S</li> </ol>	<ol style="list-style-type: none"> <li>1 FWH2768AR</li> <li>2 FWH27611AR</li> <li>3 FWH2780AR</li> </ol>	<ol style="list-style-type: none"> <li>1 FWH2768AL</li> <li>2 FWH27611AL</li> <li>3 FWH2780AL</li> </ol>	<ol style="list-style-type: none"> <li>1 FWH5068SS</li> <li>2 FWH50611SS</li> <li>3 FWH5080SS</li> </ol>	<ol style="list-style-type: none"> <li>1 FWH5068ASR</li> <li>2 FWH50611ASR</li> <li>3 FWH5080ASR</li> </ol>	<ol style="list-style-type: none"> <li>1 FWH5068SAL</li> <li>2 FWH50611SAL</li> <li>3 FWH5080SAL</li> </ol>	<ol style="list-style-type: none"> <li>1 FWH5068APLR</li> <li>2 FWH50611APLR</li> <li>3 FWH5080APLR</li> </ol>	<ol style="list-style-type: none"> <li>1 FWH5068PALR</li> <li>2 FWH50611PALR</li> <li>3 FWH5080PALR</li> </ol>	
Door Dimension	2'-8 1/8" (816)	2'-8 1/8" (816)	2'-8 1/8" (816)	5'-3 1/4" (1607)	5'-3 1/4" (1607)	5'-3 1/4" (1607)	5'-3 1/4" (1607)	5'-3 1/4" (1607)	
<b>Minimum Rough Opening</b>	2'-9" (838)	2'-9" (838)	2'-9" (838)	5'-4" (1626)	5'-4" (1626)	5'-4" (1626)	5'-4" (1626)	5'-4" (1626)	
Unobstructed Glass (single panel only)	20 7/8" (530)	20 7/8" (530)	20 7/8" (530)	20 7/8" (530)	20 7/8" (530)	20 7/8" (530)	20 7/8" (530)	20 7/8" (530)	
3 heights									
	<ol style="list-style-type: none"> <li>1 FWH2968S</li> <li>2 FWH29611S</li> <li>3 FWH2980S</li> </ol>	<ol style="list-style-type: none"> <li>1 FWH2968AR</li> <li>2 FWH29611AR</li> <li>3 FWH2980AR</li> </ol>	<ol style="list-style-type: none"> <li>1 FWH2968AL</li> <li>2 FWH29611AL</li> <li>3 FWH2980AL</li> </ol>	<ol style="list-style-type: none"> <li>1 FWH5468SS</li> <li>2 FWH54611SS</li> <li>3 FWH5480SS</li> </ol>	<ol style="list-style-type: none"> <li>1 FWH5468ASR</li> <li>2 FWH54611ASR</li> <li>3 FWH5480ASR</li> </ol>	<ol style="list-style-type: none"> <li>1 FWH5468SAL</li> <li>2 FWH54611SAL</li> <li>3 FWH5480SAL</li> </ol>	<ol style="list-style-type: none"> <li>1 FWH5468APLR</li> <li>2 FWH54611APLR</li> <li>3 FWH5480APLR</li> </ol>	<ol style="list-style-type: none"> <li>1 FWH5468PALR</li> <li>2 FWH54611PALR</li> <li>3 FWH5480PALR</li> </ol>	
Door Dimension	3'-0 1/8" (918)	3'-0 1/8" (918)	3'-0 1/8" (918)	5'-11 1/4" (1810)	5'-11 1/4" (1810)	5'-11 1/4" (1810)	5'-11 1/4" (1810)	5'-11 1/4" (1810)	
<b>Minimum Rough Opening</b>	3'-1" (940)	3'-1" (940)	3'-1" (940)	6'-0" (1829)	6'-0" (1829)	6'-0" (1829)	6'-0" (1829)	6'-0" (1829)	
Unobstructed Glass (single panel only)	24 7/8" (632)	24 7/8" (632)	24 7/8" (632)	24 7/8" (632)	24 7/8" (632)	24 7/8" (632)	24 7/8" (632)	24 7/8" (632)	
3 heights									
	<ol style="list-style-type: none"> <li>1 FWH3168S</li> <li>2 FWH31611S</li> <li>3 FWH3180S</li> </ol>	<ol style="list-style-type: none"> <li>1 FWH3168AR</li> <li>2 FWH31611AR</li> <li>3 FWH3180AR</li> </ol>	<ol style="list-style-type: none"> <li>1 FWH3168AL</li> <li>2 FWH31611AL</li> <li>3 FWH3180AL</li> </ol>	<ol style="list-style-type: none"> <li>1 FWH6068SS</li> <li>2 FWH60611SS</li> <li>3 FWH6080SS</li> </ol>	<ol style="list-style-type: none"> <li>1 FWH6068ASR</li> <li>2 FWH60611ASR</li> <li>3 FWH6080ASR</li> </ol>	<ol style="list-style-type: none"> <li>1 FWH6068SAL</li> <li>2 FWH60611SAL</li> <li>3 FWH6080SAL</li> </ol>	<ol style="list-style-type: none"> <li>1 FWH6068APLR</li> <li>2 FWH60611APLR</li> <li>3 FWH6080APLR</li> </ol>	<ol style="list-style-type: none"> <li>1 FWH6068PALR</li> <li>2 FWH60611PALR</li> <li>3 FWH6080PALR</li> </ol>	



Custom-size doors are available in 1/8" (3) increments. See page 155 for custom sizes and specifications.

Stationary (S) doors can be used as an individual unit or as a sidelight. In addition to venting door panels shown in table, other standard configurations are available for two- and three-panel doors.

Grille patterns shown on page 155.

\* "Door Dimension" always refers to outside frame to frame dimension.  
 \*\* "Minimum Rough Opening" dimensions may need to be increased to allow for use of building wraps, flashing, sill panning, brackets, fasteners or other items. See pages 210-211 for more details.  
 \* Dimensions in parentheses are in millimeters.

**Three Patio Door Heights**

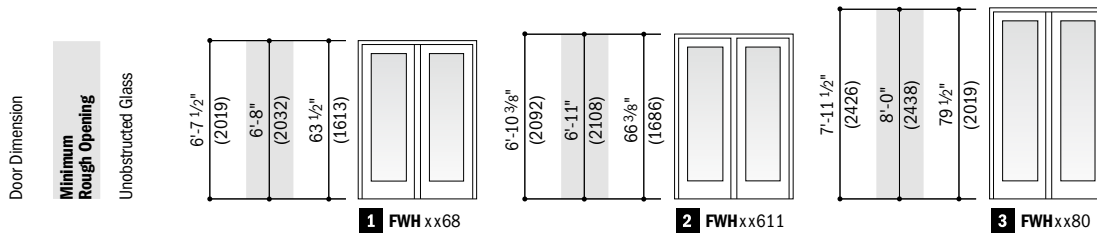

**Order Designation Description**

Viewed from the exterior.

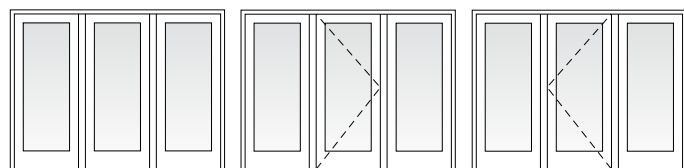
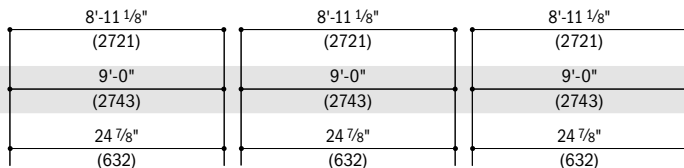
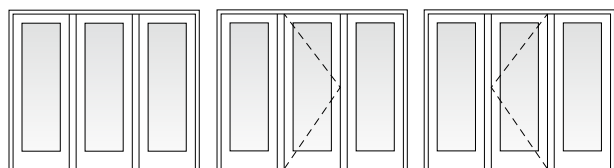
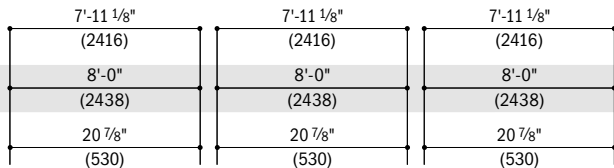
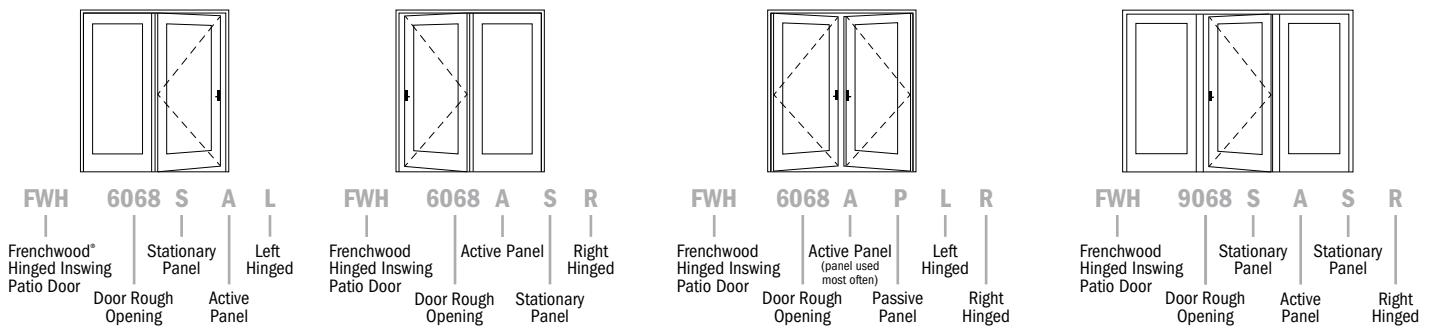

\*"Door Dimension" always refers to outside frame to frame dimension.  
 \*"Minimum Rough Opening" dimensions may need to be increased to allow for use of building wraps, flashing, sill panning, brackets, fasteners or other items. See pages 210-211 for more details.  
 •Dimensions in parentheses are in millimeters.

400 Series  
Frenchwood® Hinged  
Inswing Patio Doors

# FRENCHWOOD® HINGED INSWING PATIO DOORS

## Frenchwood® Hinged Inswing Patio Door Opening and Area Specifications

Door Number	Number of Panels in Open Position*	Clear Opening Area Sq. Ft./ (m <sup>2</sup> )	Clear Opening Maximums			Glass Area Sq. Ft./ (m <sup>2</sup> )	Vent Area Sq. Ft./ (m <sup>2</sup> )	Overall Door Area Sq. Ft./ (m <sup>2</sup> )
			90° Open Position Width Inches/(mm)	Full Open Position Width Inches/(mm)	Height Inches/(mm)			
<b>FWH2168S</b>	-	-	-	-	-	5.74 (0.53)	-	13.39 (1.24)
<b>FWH2768</b>	1	12.98 (1.21)	24 13/16" (630)	26" (660)	75 1/4" (1911)	8.32 (0.77)	12.98 (1.21)	16.63 (1.55)
<b>FWH2968</b>	1	14.02 (1.30)	26 13/16" (681)	28" (711)	75 1/4" (1911)	9.20 (0.86)	14.02 (1.30)	17.74 (1.65)
<b>FWH3168</b>	1	16.11 (1.50)	30 13/16" (783)	32" (813)	75 1/4" (1911)	10.96 (1.02)	16.11 (1.50)	19.95 (1.85)
<b>FWH4168</b>	2	21.43 (1.99)	41" (1039)	43 7/8" (1112)	75 1/4" (1911)	11.68 (1.09)	21.43 (1.99)	26.50 (2.46)
<b>FWH4168</b>	1	11.01 (1.02)	19 7/8" (505)	21 1/16" (535)	75 1/4" (1911)	11.68 (1.09)	11.01 (1.02)	26.50 (2.46)
<b>FWH5068</b>	1 - AS/SA	12.98 (1.21)	24 13/16" (630)	26" (660)	75 1/4" (1911)	16.64 (1.55)	12.98 (1.21)	32.71 (3.04)
<b>FWH5068</b>	2 - AP/PA	27.30 (2.54)	52 1/4" (1327)	55 1/8" (1400)	75 1/4" (1911)	16.64 (1.55)	27.30 (2.54)	32.71 (3.04)
<b>FWH5068</b>	1 - AP/PA	13.32 (1.23)	25 1/2" (647)	26 11/16" (678)	75 1/4" (1911)	16.64 (1.55)	13.32 (1.23)	32.71 (3.04)
<b>FWH5468</b>	1 - AS/SA	14.02 (1.30)	26 13/16" (681)	28" (711)	75 1/4" (1911)	18.39 (1.71)	14.02 (1.30)	34.92 (3.24)
<b>FWH5468</b>	2 - AP/PA	29.39 (2.73)	56 1/4" (1429)	59 1/8" (1502)	75 1/4" (1911)	18.39 (1.71)	29.39 (2.73)	34.92 (3.24)
<b>FWH5468</b>	1 - AP/PA	14.37 (1.33)	27 1/2" (698)	28 11/16" (729)	75 1/4" (1911)	18.39 (1.71)	14.37 (1.33)	34.92 (3.24)
<b>FWH6068</b>	1 - AS/SA	16.11 (1.50)	30 13/16" (783)	32" (813)	75 1/4" (1911)	21.92 (2.04)	16.11 (1.50)	39.34 (3.66)
<b>FWH6068</b>	2 - AP/PA	33.58 (3.12)	64 1/2" (1632)	67 1/8" (1705)	75 1/4" (1911)	21.92 (2.04)	33.58 (3.12)	39.34 (3.66)
<b>FWH6068</b>	1 - AP/PA	16.46 (1.52)	31 1/2" (800)	32 11/16" (830)	75 1/4" (1911)	21.92 (2.04)	16.46 (1.52)	39.34 (3.66)
<b>FWH8068</b>	1	14.02 (1.30)	26 13/16" (681)	28" (711)	75 1/4" (1911)	27.60 (2.56)	14.02 (1.30)	52.52 (4.88)
<b>FWH9068</b>	1	16.11 (1.50)	30 13/16" (783)	32" (813)	75 1/4" (1911)	32.88 (3.06)	16.11 (1.50)	59.14 (5.49)
<b>FWH21611S</b>	-	-	-	-	-	6.01 (0.56)	-	13.89 (1.29)
<b>FWH27611</b>	1	13.48 (1.25)	24 13/16" (630)	26" (660)	78 1/8" (1984)	8.69 (0.81)	13.48 (1.25)	17.21 (1.60)
<b>FWH29611</b>	1	14.55 (1.35)	26 13/16" (681)	28" (711)	78 1/8" (1984)	9.61 (0.89)	14.55 (1.35)	18.36 (1.71)
<b>FWH31611</b>	1	16.72 (1.55)	30 13/16" (783)	32" (813)	78 1/8" (1984)	11.45 (1.06)	16.72 (1.55)	20.64 (1.92)
<b>FWH41611</b>	2	22.24 (2.07)	41" (1039)	43 7/8" (1112)	78 1/8" (1984)	12.20 (1.13)	22.24 (2.07)	27.46 (2.55)
<b>FWH41611</b>	1	11.43 (1.06)	19 7/8" (505)	21 1/16" (535)	78 1/8" (1984)	12.20 (1.13)	11.43 (1.06)	27.46 (2.55)
<b>FWH50611</b>	1 - AS/SA	13.48 (1.25)	24 13/16" (630)	26" (660)	78 1/8" (1984)	17.38 (1.62)	13.48 (1.25)	33.89 (3.15)
<b>FWH50611</b>	2 - AP/PA	28.34 (2.63)	52 1/4" (1327)	55 1/8" (1400)	78 1/8" (1984)	17.38 (1.62)	28.34 (2.63)	33.89 (3.15)
<b>FWH50611</b>	1 - AP/PA	13.83 (1.28)	25 1/2" (647)	26 11/16" (678)	78 1/8" (1984)	17.38 (1.62)	13.83 (1.28)	33.89 (3.15)
<b>FWH54611</b>	1 - AS/SA	14.55 (1.35)	26 13/16" (681)	28" (660)	78 1/8" (1984)	19.22 (1.79)	14.55 (1.35)	36.18 (3.36)
<b>FWH54611</b>	2 - AP/PA	30.51 (2.83)	56 1/4" (1429)	59 1/8" (1502)	78 1/8" (1984)	19.22 (1.79)	30.51 (2.83)	36.18 (3.36)
<b>FWH54611</b>	1 - AP/PA	14.91 (1.58)	27 1/2" (698)	28 11/16" (729)	78 1/8" (1984)	19.22 (1.79)	14.91 (1.58)	36.18 (3.36)
<b>FWH60611</b>	1 - AS/SA	16.72 (1.55)	30 13/16" (783)	32" (813)	78 1/8" (1984)	22.91 (2.13)	16.72 (1.55)	40.76 (3.79)
<b>FWH60611</b>	2 - AP/PA	34.86 (3.24)	64 1/2" (1632)	67 1/8" (1705)	78 1/8" (1984)	22.91 (2.13)	34.86 (3.24)	40.76 (3.79)
<b>FWH60611</b>	1 - AP/PA	17.08 (1.68)	31 1/2" (800)	32 11/16" (830)	78 1/8" (1984)	22.91 (2.13)	17.08 (1.68)	40.76 (3.79)
<b>FWH80611</b>	1	14.55 (1.35)	26 13/16" (681)	28" (660)	78 1/8" (1984)	28.83 (2.68)	14.55 (1.35)	54.43 (5.06)
<b>FWH90611</b>	1	16.72 (1.55)	30 13/16" (783)	32" (813)	78 1/8" (1984)	34.36 (3.19)	16.72 (1.55)	61.30 (5.70)
<b>FWH2180S</b>	-	-	-	-	-	7.19 (0.67)	-	16.08 (1.49)
<b>FWH2780</b>	1	15.73 (1.46)	24 13/16" (630)	26" (660)	91 1/4" (2318)	10.41 (0.97)	15.73 (1.46)	19.98 (1.86)
<b>FWH2980</b>	1	17.00 (1.58)	26 13/16" (681)	28" (711)	91 1/4" (2318)	11.52 (1.07)	17.00 (1.58)	21.31 (1.98)
<b>FWH3180</b>	1	19.54 (1.82)	30 13/16" (783)	32" (813)	91 1/4" (2318)	13.72 (1.28)	19.54 (1.82)	23.96 (2.23)
<b>FWH4180</b>	2	25.98 (2.41)	41" (1039)	43 7/8" (1112)	91 1/4" (2318)	14.62 (1.36)	25.98 (2.41)	31.83 (2.96)
<b>FWH4180</b>	1	13.35 (1.24)	19 7/8" (505)	21 1/16" (535)	91 1/4" (2318)	14.62 (1.36)	13.35 (1.24)	31.83 (2.96)
<b>FWH5080</b>	1 - AS/SA	15.73 (1.46)	24 13/16" (630)	26" (660)	91 1/4" (2318)	20.82 (1.93)	15.73 (1.46)	39.30 (3.65)
<b>FWH5080</b>	2 - AP/PA	33.11 (3.08)	52 1/4" (1327)	55 1/8" (1400)	91 1/4" (2318)	20.82 (1.93)	33.11 (3.08)	39.30 (3.65)
<b>FWH5080</b>	1 - AP/PA	16.15 (1.50)	25 1/2" (647)	26 11/16" (678)	91 1/4" (2318)	20.82 (1.93)	16.15 (1.50)	39.30 (3.65)
<b>FWH5480</b>	1 - AS/SA	17.00 (1.58)	26 13/16" (681)	28" (660)	91 1/4" (2318)	23.03 (2.14)	17.00 (1.58)	41.95 (3.90)
<b>FWH5480</b>	2 - AP/PA	35.64 (3.31)	56 1/4" (1429)	59 1/8" (1502)	91 1/4" (2318)	23.03 (2.14)	35.64 (3.31)	41.95 (3.90)
<b>FWH5480</b>	1 - AP/PA	17.42 (1.61)	27 1/2" (698)	28 11/16" (729)	91 1/4" (2318)	23.03 (2.14)	17.42 (1.61)	41.95 (3.90)
<b>FWH6080</b>	1 - AS/SA	19.54 (1.82)	30 13/16" (783)	32" (813)	91 1/4" (2318)	27.44 (2.55)	19.54 (1.82)	47.25 (4.39)
<b>FWH6080</b>	2 - AP/PA	40.71 (3.78)	64 1/2" (1632)	67 1/8" (1705)	91 1/4" (2318)	27.44 (2.55)	40.71 (3.78)	47.25 (4.39)
<b>FWH6080</b>	1 - AP/PA	19.96 (1.85)	31 1/2" (800)	32 11/16" (830)	91 1/4" (2318)	27.44 (2.55)	19.96 (1.85)	47.25 (4.39)
<b>FWH8080</b>	1	17.00 (1.58)	26 13/16" (681)	28" (660)	91 1/4" (2318)	34.55 (3.21)	17.00 (1.58)	63.09 (5.86)
<b>FWH9080</b>	1	19.54 (1.82)	30 13/16" (783)	32" (813)	91 1/4" (2318)	41.16 (3.82)	19.54 (1.82)	71.05 (6.60)

\* Dimensions in parentheses are in millimeters or square meters.

\* For two-panel AP/PA doors with only one panel open, clear opening is based on the active panel open and the passive panel closed.

**Custom Sizes and Specification Formulas**

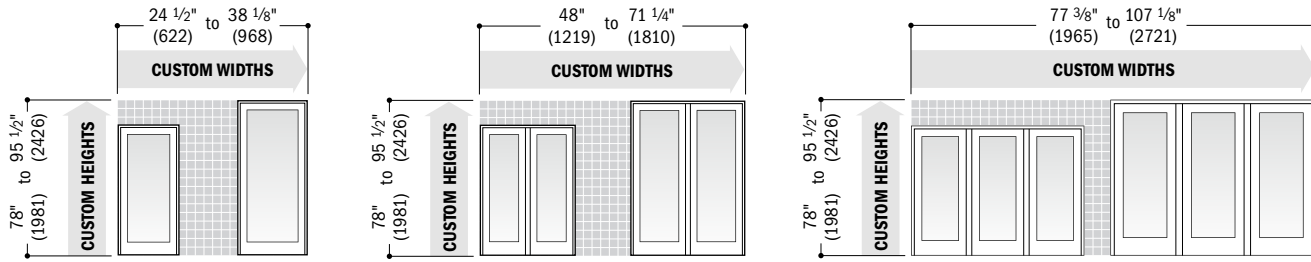

<b>Clear Opening</b>  	Height = height - 4.22" (107)  <b>Single-Panel</b> Width = width - 5.744" (145)  <b>Two-Panel, two panels open</b> Width = width - 7.394" (187)  <b>Two-Panel, one panel open</b> Width = (width - 10.550" (267)) + 2  <b>Three-Panel</b> Width = (width - 16.106" (409)) + 3	<b>Minimum R.O.</b> 	Width = width + 3/4" (19)  Height = height + 1/2" (13)	<b>Unobstr. Glass</b> 	<b>Single-Panel</b> Width = width - 11.22" (285) Height = height - 16.05" (408)  <b>Two-Panel</b> Width = width - 21.5" (546) Height = height - 16.05" (408)  <b>Three-Panel</b> Width = width - 32.55" (827) Height = height - 16.05" (408)
------------------------------	---	-------------------------	--	---------------------------	--

- Dimensions in parentheses are in millimeters.
- **Clear Opening** formulas provide dimensions for determining area available for egress. Vent opening, or area available for passage of air, is equal to clear opening. **Minimum R.O.** (minimum rough opening) formulas provide minimum rough opening width and height dimensions. **Unobstr. Glass** (unobstructed glass) formulas provide dimensions for determining area available for passage of light.
- Clear opening width formulas are based on panel(s) in a 90° open position.



Available in 1/8" (3) increments between minimum and maximum widths and heights. Some restrictions apply. Measurement guide can be found at [andersenwindows.com/measure](http://andersenwindows.com/measure).

**Grille Patterns**

	Prairie A	Colonial	Modified Colonial	Modified Colonial with Simulated Meeting Rail	Tall Fractional	Tall Fractional with Simulated Meeting Rail	Short Fractional	Short Fractional with Simulated Meeting Rail
<b>Frenchwood® Hinged Inswing Patio Doors</b>								

**Number of lights and overall pattern varies with panel size. Patterns are not available in all configurations.** Specified equal light and custom patterns are also available. For more grille options, see page 13 or visit [andersenwindows.com/grilles](http://andersenwindows.com/grilles).

**Interior Extension Jamb**

Use of interior extension jambs or drywall return will restrict panel operation on jamb-hinged patio doors. Jamb-hinged patio doors must be installed flush to the interior to achieve full panel operation.

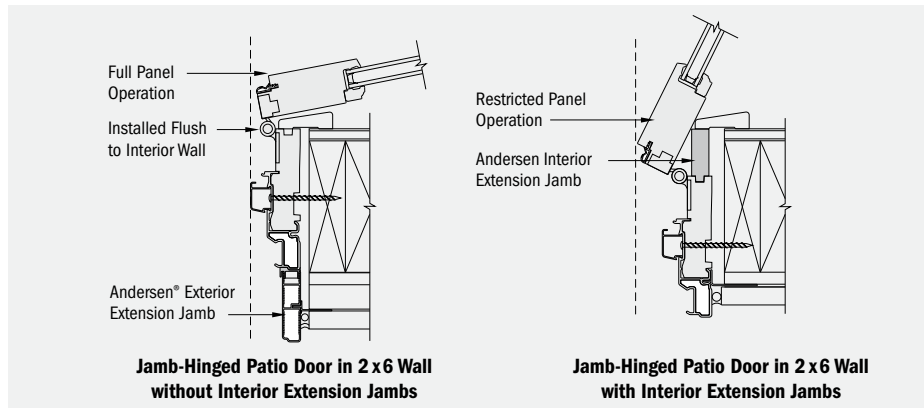

400 Series  
Frenchwood® Hinged  
Inswing Patio Doors

# FRENCHWOOD® HINGED INSWING PATIO DOORS

## Frenchwood® Hinged Inswing Patio Door Details

Scale 1 1/2" (38) = 1'-0" (305) – 1:8

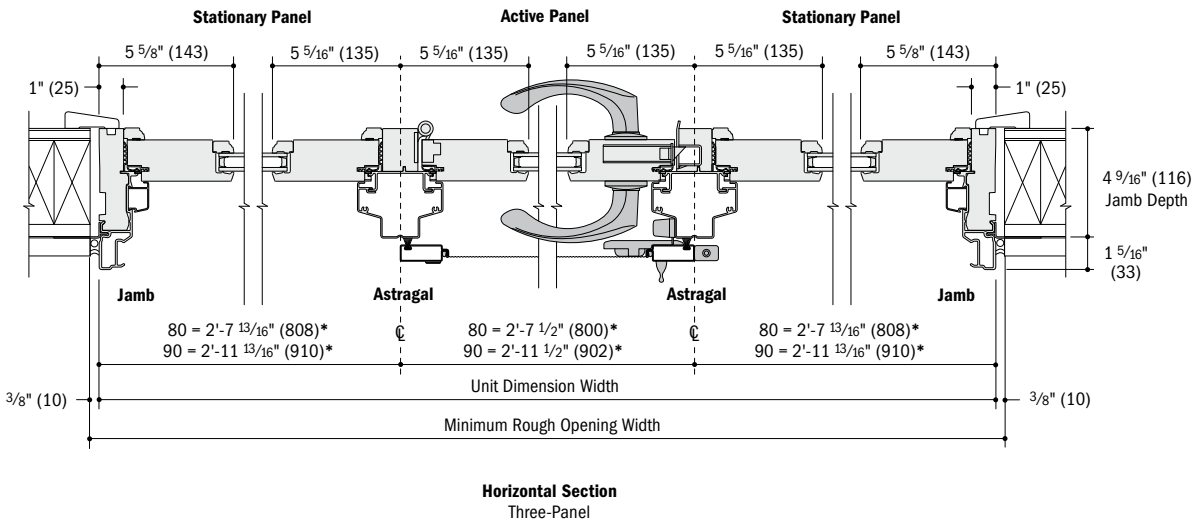
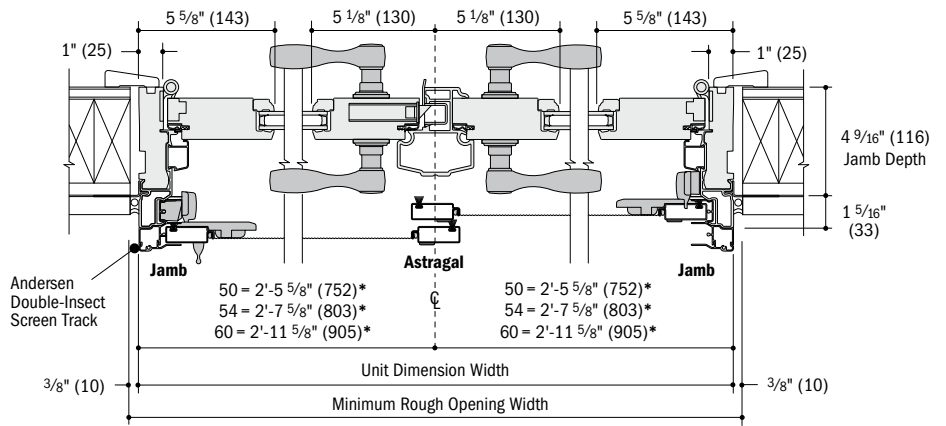
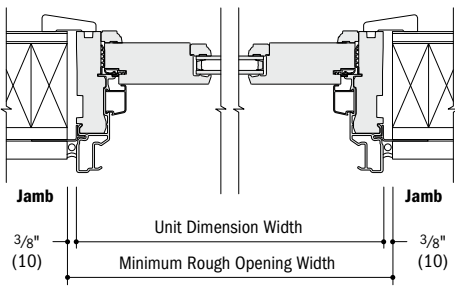
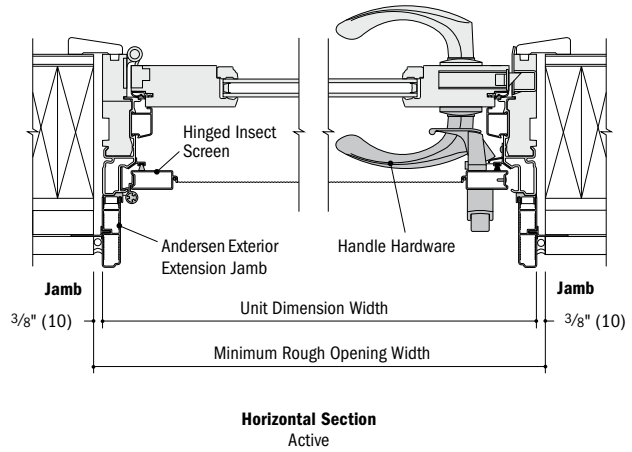
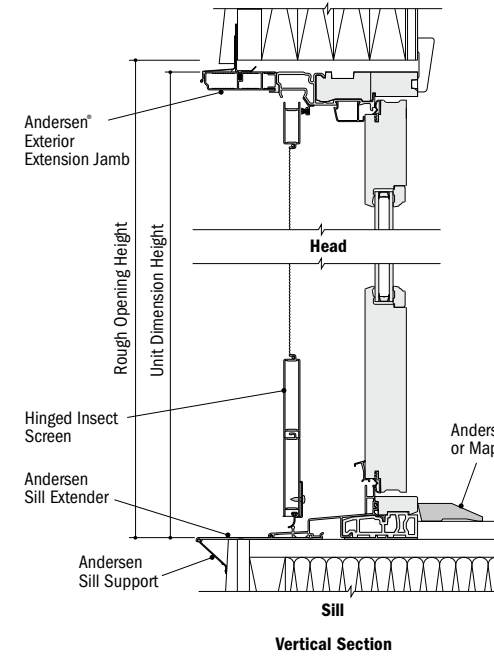

- 4 9/16" (116) jamb depth measurement is from back side of installation flange.
- Light-colored areas are parts included with door. Dark-colored areas are additional Andersen® parts required to complete door assembly as shown.
- Rough openings may need to be increased to allow for use of building wraps, flashing, sill panning, brackets, fasteners or other items. See installation information on pages 210-211.
- Details are for illustration only and are not intended to represent product installation methods or materials. Refer to product installation guides at andersenwindows.com.
- Dimensions in parentheses are in millimeters.
- Dimension indicates location of astragal centerline.

**Clear Opening Details**

Scale 1 1/2" (38) = 1'-0" (305) – 1:8

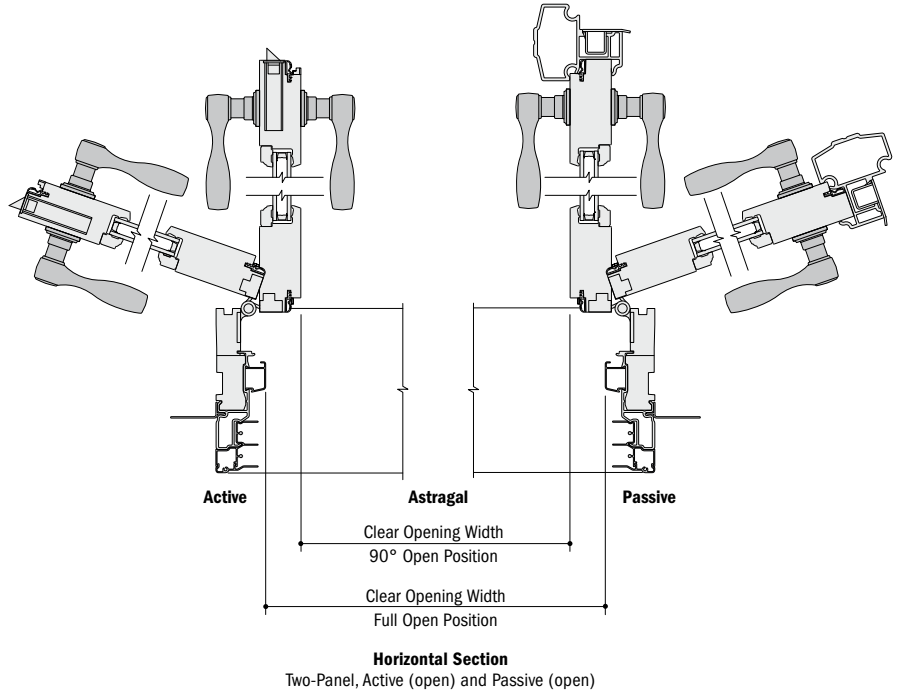
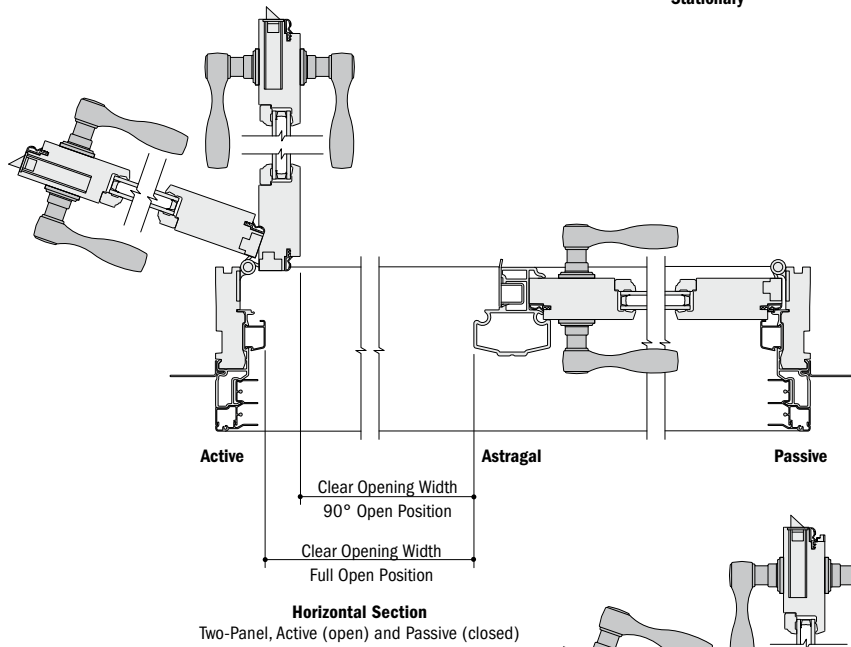
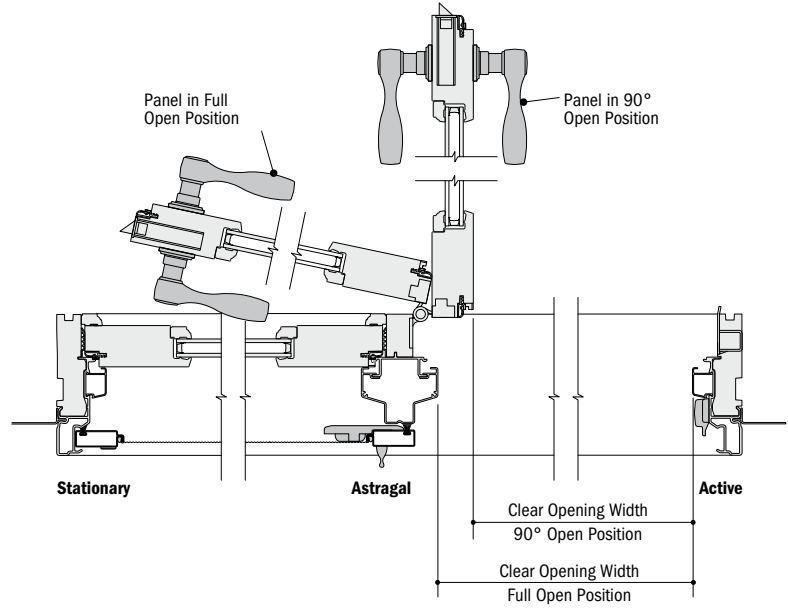
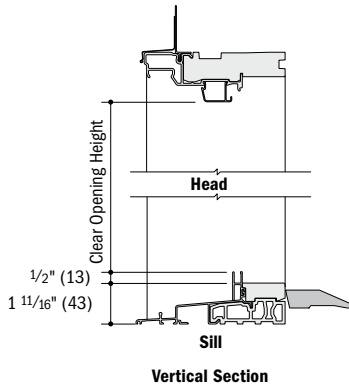

\* Light-colored areas are parts included with door. Dark-colored areas are additional Andersen® parts required to complete door assembly as shown.  
 \* Rough openings may need to be increased to allow for use of building wraps, flashing, sill panning, brackets, fasteners or other items. See installation information on pages 210-211.  
 \* Details are for illustration only and are not intended to represent product installation methods or materials. Refer to product installation guides at andersenwindows.com.  
 \* Dimensions in parentheses are in millimeters.

400 Series  
Frenchwood® Hinged  
Inswing Patio Doors

# FRENCHWOOD® HINGED INSWING PATIO DOORS

## Ramped Sill Detail

Scale 1 1/2" (38) = 1'-0" (305) – 1:8

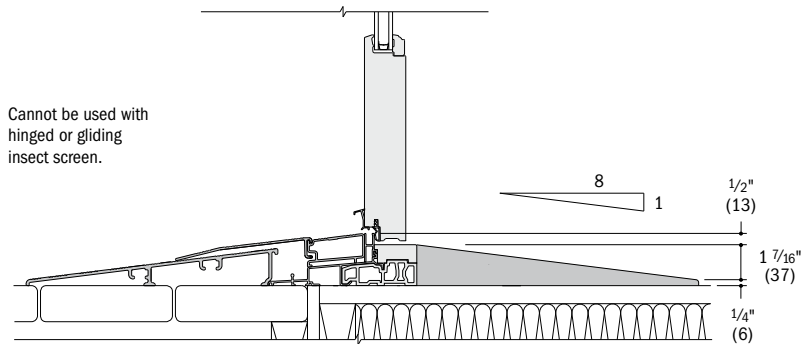

Vertical Section

## Vertical Joining Detail

Scale 1 1/2" (38) = 1'-0" (305) – 1:8

### Overall Door Dimension Width

Sum of individual door widths plus 3/16" (5) for each join.

### Overall Rough Opening Width

Overall door dimension width plus 3/4" (19).

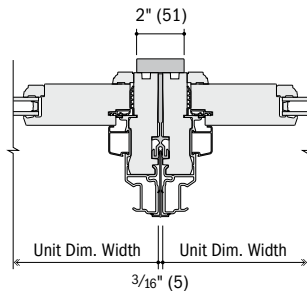

Horizontal Section  
Frenchwood® Hinged Inswing to Frenchwood Hinged Inswing

## Vertical Joining Detail - LVL

Scale 1 1/2" (38) = 1'-0" (305) – 1:8

### Overall Door Dimension Width

Sum of individual door widths plus 3/4" (19) for each join.

### Overall Rough Opening Width

Overall door dimension width plus 3/4" (19).

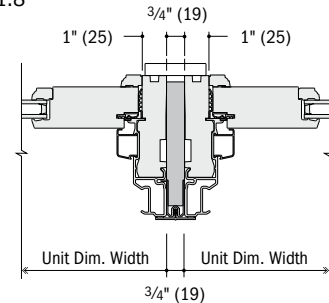

Horizontal Section  
Frenchwood Hinged Inswing to Frenchwood Hinged Inswing

Andersen does not recommend joining of hinge jamb to hinge jamb. For more joining information, see the combination designs section starting on page 181.

## Separate Rough Openings Detail

Scale 1 1/2" (38) = 1'-0" (305) – 1:8

To meet structural requirements or to achieve a wider joined appearance, doors may be installed into separate rough openings having vertical support (by others) in combination with Andersen® exterior filler and exterior vinyl trim.

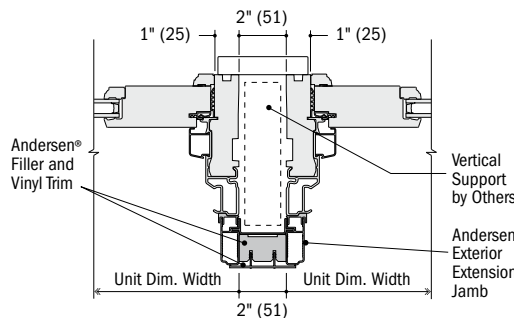

Horizontal Section  
Frenchwood Hinged Inswing and Frenchwood Hinged Inswing

\* Light-colored areas are parts included with door. Dark-colored areas are additional Andersen® parts required to complete door assembly as shown.

\* **Rough openings may need to be increased to allow for use of building wraps, flashing, sill panning, brackets, fasteners or other items. See installation information on page 210-211.**

\* Details are for illustration only and are not intended to represent product installation methods or materials. Refer to product installation guides at andersenwindows.com.

\* Andersen recommends installation of doors into separate rough openings. Consult with an architect or structural engineer regarding minimum requirements for structural support members between adjacent rough openings.

\* Dimensions in parentheses are in millimeters.

# FRENCHWOOD<sup>®</sup> PATIO DOOR SIDELIGHTS & TRANSOMS



## SECTION REFERENCE

Table of Sizes.....	161
Specifications .....	161
Custom Sizing.....	162
Sidelight & Transom Details.....	162
Combination Designs.....	181
Product Performance.....	194

**CUSTOM SIZING**  
in 1/8" (3) increments



Dimensions in parentheses are in millimeters.

# FRENCHWOOD® PATIO DOOR SIDELIGHTS & TRANSOMS

## FEATURES

### Frame

**A** All basic exterior frame members are fiberglass reinforced composite, which maintains an attractive appearance while minimizing maintenance.

**B** The frame members are attached to a water-repellent preservative-treated wood subframe for long-lasting\* protection and performance. The subframe is grooved to accept extension jambs.

**C** The exterior of the wood door panel is protected with a long-lasting\* urethane base finish in white, Sandtone, Terratone or forest green.

**D** Panel interior surfaces are unfinished pine veneer. Unfinished oak and maple veneers are available as options. Low-maintenance prefinished white interiors are also available.

**E** The sill of the Frenchwood patio door sidelight is made with three-piece construction. The subsill is made of Fibrex® material, and the sill step is solid oak. The exterior sill member is made of extruded aluminum with an attractive wear-resistant, heat-baked finish in a neutral color. This combination of materials combines durability and low maintenance with excellent insulating characteristics.

### Glass

**F** Panels are silicone bed glazed and finished with an interior wood stop.

**G** High-Performance glass options include:

- Low-E4® tempered glass
- Low-E4 HeatLock® tempered glass
- Low-E4 Sun tempered glass
- Low-E4 SmartSun™ tempered glass
- Low-E4 SmartSun HeatLock tempered glass

Additional glass options are available. Contact your Andersen supplier.

A removable translucent film helps shield the glass from damage during delivery and construction and simplifies finishing at the jobsite.

### Patterned Glass

Patterned glass options are available. See page 12 for more details.

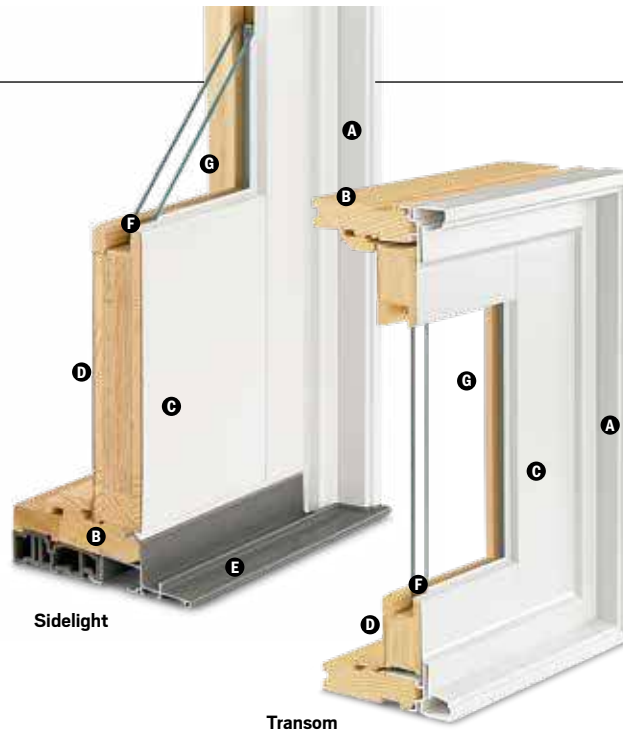

## EXTERIOR



## INTERIOR

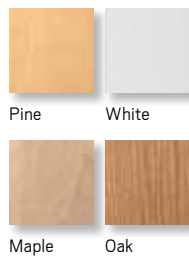

Prefinished white interiors are only available on units with white exteriors. Naturally occurring variations in grain, color and texture of wood make each product one of a kind. All wood interiors are unfinished unless prefinished white is specified.



Frenchwood patio door sidelights, transoms and sidelight transoms elegantly frame our 400 Series Frenchwood patio doors.

LVL reinforced joining materials are available in 4 9/16" (116) and 6 9/16" (167) depths. See pages 191-192.

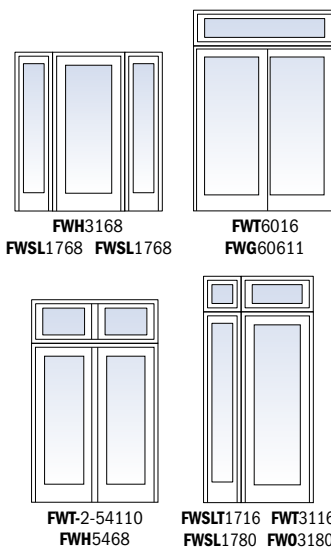

## ACCESSORIES Sold Separately

### Frame

#### Extension Jambs

Standard jamb depth is 4 9/16" (116). Pine, oak or maple veneer or prefinished white interior extension jambs are available in 1/16" (1.5) increments between 5 1/16" (129) and 7 1/8" (181).

### Glass

#### Andersen® Art Glass

Andersen art glass panels come in a variety of original patterns. See pages 173-174 for details on Andersen art glass. Visit [andersenwindows.com/artglass](http://andersenwindows.com/artglass) for details and pattern information.

### Grilles

Grilles are available in a variety of configurations and widths.

### Exterior Trim

This product is available with Andersen exterior trim. See pages 175-180 for details.

### CAUTION:

- Painting and staining may cause damage to rigid vinyl.
- Do not paint 400 Series patio doors, sidelights and transoms with white, canvas, Sandtone, forest green, dark bronze or black exterior colors.
- Andersen does not warrant the adhesion or performance of homeowner-applied paint over vinyl or other factory-coated surfaces.
- 400 Series patio doors, sidelights and transoms in Terratone color may be painted any color lighter than Terratone color using quality oil-based or latex paint.
- For vinyl painting instructions and preparation, contact your Andersen supplier.
- Do not paint weatherstrip.
- Creosote-based stains should not come in contact with Andersen products.
- Abrasive cleaners or solutions containing corrosive solvents should not be used on Andersen products.

For more information about **glass, patterned glass, art glass and grilles**, see pages 12-14.

For more information about **combination designs, product performance, installation instructions and accessories**, see pages 181-211 or visit [andersenwindows.com](http://andersenwindows.com).

\* Visit [andersenwindows.com/warranty](http://andersenwindows.com/warranty) for details.

Dimensions in parentheses are in millimeters.

Printing limitations prevent exact duplication of colors and finishes. See your Andersen supplier for actual color and finish samples.

**Table of Frenchwood® Patio Door Transom, Sidelight Transom and Sidelight Sizes**

Scale 1/8" (3) = 1'-0" (305) – 1:96

Transom/Sidelight Dimension	1'-2 13/16" (376)	1'-6 13/16" (478)	2'-0 1/2" (622)	2'-6 1/8" (765)	2'-8 1/8" (816)	3'-0 1/8" (918)	4'-0" (1219)	4'-11 1/4" (1505)	5'-3 1/4" (1607)	5'-11 1/4" (1810)
<b>Minimum Rough Opening</b>	1'-3 1/2" (394)	1'-7 1/2" (495)	2'-1" (635)	2'-7" (787)	2'-9" (838)	3'-1" (940)	4'-1" (1245)	5'-0" (1524)	5'-4" (1626)	6'-0" (1829)
Unobstructed Glass (single sash only)	6 3/8" (162)	10 3/8" (264)	13 5/16" (338)	18 15/16" (481)	20 15/16" (532)	24 15/16" (633)	36 13/16" (935) 13 5/16" (338)	48 1/16" (1221) 18 15/16" (481)	52 1/16" (1322) 20 15/16" (532)	60 1/16" (1526) 24 15/16" (633)

Custom-size doors are available in 1/8" (3) increments.  
See page 162 for custom sizes and specifications

\* "Transom/Sidelight Dimension" always refers to outside frame to frame dimension.  
\* "Minimum Rough Opening" dimensions may need to be increased to allow for use of building wraps, flashing, sill panning, brackets, fasteners or other items. See pages 210-211 for more details.  
\* Dimensions in parentheses are in millimeters.

**Frenchwood® Patio Door Sidelight Area Specifications**

Sidelight Number	Glass Area Sq. Ft./ (m <sup>2</sup> )	Overall Window Area Sq. Ft./ (m <sup>2</sup> )
<b>FWSL1368</b>	2.82 (0.26)	8.18 (0.76)
<b>FWSL1768</b>	4.58 (0.43)	10.39 (0.97)
<b>FWSL13611</b>	2.95 (0.27)	8.47 (0.79)
<b>FWSL17611</b>	4.79 (0.45)	10.76 (1.00)
<b>FWSL1380</b>	3.53 (0.33)	9.82 (0.91)
<b>FWSL1780</b>	5.74 (0.53)	12.48 (1.16)

**Frenchwood® Patio Door Sidelight Transom Area Specifications**

Sidelight Transom Number	Glass Area Sq. Ft./ (m <sup>2</sup> )	Overall Window Area Sq. Ft./ (m <sup>2</sup> )
<b>FWSLT1311</b>	0.20 (0.02)	1.32 (0.12)
<b>FWSLT1316</b>	0.42 (0.04)	1.83 (0.17)
<b>FWSLT13110</b>	0.60 (0.06)	2.24 (0.21)
<b>FWSLT1711</b>	0.32 (0.03)	1.67 (0.16)
<b>FWSLT1716</b>	0.68 (0.06)	2.33 (0.22)
<b>FWSLT17110</b>	0.97 (0.09)	2.85 (0.27)

**Frenchwood® Patio Door Transom Area Specifications**

Transom Number	Glass Area Sq. Ft./ (m <sup>2</sup> )	Overall Window Area Sq. Ft./ (m <sup>2</sup> )
<b>FWT2111</b>	0.41 (0.04)	2.18 (0.20)
<b>FWT2116</b>	0.87 (0.08)	3.03 (0.28)
<b>FWT21110</b>	1.24 (0.12)	3.71 (0.35)
<b>FWT2711</b>	0.58 (0.05)	2.68 (0.25)
<b>FWT2716</b>	1.24 (0.12)	3.73 (0.35)
<b>FWT27110</b>	1.77 (0.16)	4.56 (0.42)
<b>FWT2911</b>	0.64 (0.06)	2.86 (0.27)
<b>FWT2916</b>	1.37 (0.13)	3.97 (0.37)
<b>FWT29110</b>	1.95 (0.18)	4.87 (0.45)
<b>FWT3111</b>	0.76 (0.07)	3.21 (0.30)
<b>FWT3116</b>	1.63 (0.15)	4.47 (0.42)
<b>FWT31110</b>	2.33 (0.22)	5.47 (0.51)

**Frenchwood® Patio Door Transom Area Specifications**

Transom Number	Glass Area Sq. Ft./ (m <sup>2</sup> )	Overall Window Area Sq. Ft./ (m <sup>2</sup> )
<b>FWT4111</b>	1.13 (0.11)	4.27 (0.40)
<b>FWT4116</b>	2.41 (0.22)	5.94 (0.55)
<b>FWT41110</b>	3.43 (0.32)	7.27 (0.68)
<b>FWT5011</b>	1.47 (0.14)	5.27 (0.49)
<b>FWT5016</b>	3.14 (0.29)	7.33 (0.68)
<b>FWT50110</b>	4.48 (0.42)	8.98 (0.83)
<b>FWT5411</b>	1.59 (0.15)	5.63 (0.52)
<b>FWT5416</b>	3.40 (0.32)	7.82 (0.73)
<b>FWT54110</b>	4.85 (0.45)	9.58 (0.89)
<b>FWT6011</b>	1.84 (0.17)	6.34 (0.59)
<b>FWT6016</b>	3.93 (0.37)	8.81 (0.82)
<b>FWT60110</b>	5.60 (0.52)	10.79 (1.00)
<b>FWT-2 4111</b>	0.82 (0.08)	4.27 (0.40)
<b>FWT-2 4116</b>	1.74 (0.16)	5.94 (0.55)
<b>FWT-2 41110</b>	2.49 (0.23)	7.27 (0.68)
<b>FWT-2 5011</b>	1.16 (0.11)	5.27 (0.49)
<b>FWT-2 5016</b>	2.48 (0.23)	7.33 (0.68)
<b>FWT-2 50110</b>	3.53 (0.33)	8.98 (0.83)
<b>FWT-2 5411</b>	1.28 (0.12)	5.63 (0.52)
<b>FWT-2 5416</b>	2.74 (0.26)	7.82 (0.73)
<b>FWT-2 54110</b>	3.91 (0.36)	9.58 (0.89)
<b>FWT-2 6011</b>	1.53 (0.14)	6.34 (0.59)
<b>FWT-2 6016</b>	3.26 (0.30)	8.81 (0.82)
<b>FWT-2 60110</b>	4.65 (0.43)	10.79 (1.00)

\* Dimensions in parentheses are in square meters

# FRENCHWOOD® PATIO DOOR SIDELIGHTS & TRANSOMS

## Custom Sizes and Specification Formulas



Available in 1/8" (3) increments between minimum and maximum widths and heights. Some restrictions apply. Measurement guide can be found at [andersenwindows.com/measure](http://andersenwindows.com/measure).

### Sidelight Transoms

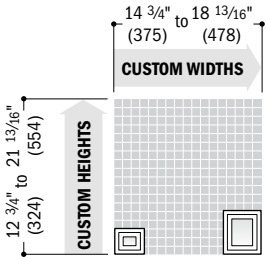

### Transoms

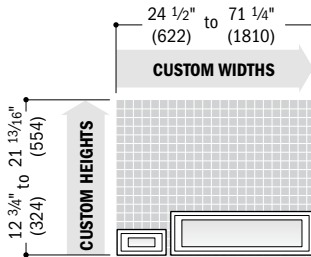

### Sidelights

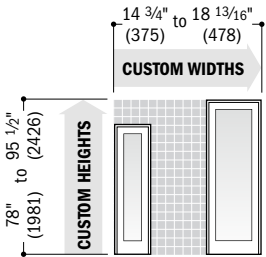

### Twin Transoms

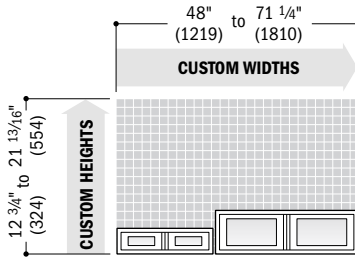

Minimum R.O.	Transoms, Twin Transoms & Sidelight Transoms
	Width = width + 3/4" (19) Height = height + 3/4" (19)
	Width = width + 3/4" (19) Height = height + 1/2" (13)
Unobstr. Glass	Transoms
	Width = window width - 11.15" (283) Height = window height - 8.4" (213)
	Width = window width - 21.30" (541) Height = window height - 8.4" (213)
	Width = window width - 8.4" (213) Height = window height - 8.4" (213)
	Width = window width - 8.4" (213) Height = window height - 16.06" (408)

\* **Minimum R.O.** (minimum rough opening) formulas provide minimum rough opening width and height dimensions. **Unobstr. Glass** (unobstructed glass) formulas provide dimensions for determining area available for passage of light.

## Frenchwood® Patio Door Transom and Sidelight Details

Scale 1 1/2" (38) = 1'-0" (305) - 1:8

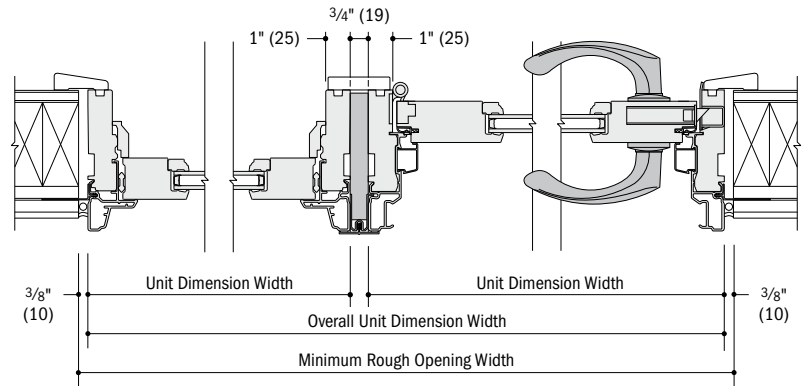

**Horizontal Section**  
Frenchwood® Patio Door Sidelight to Frenchwood® Hinged Inswing Patio Door

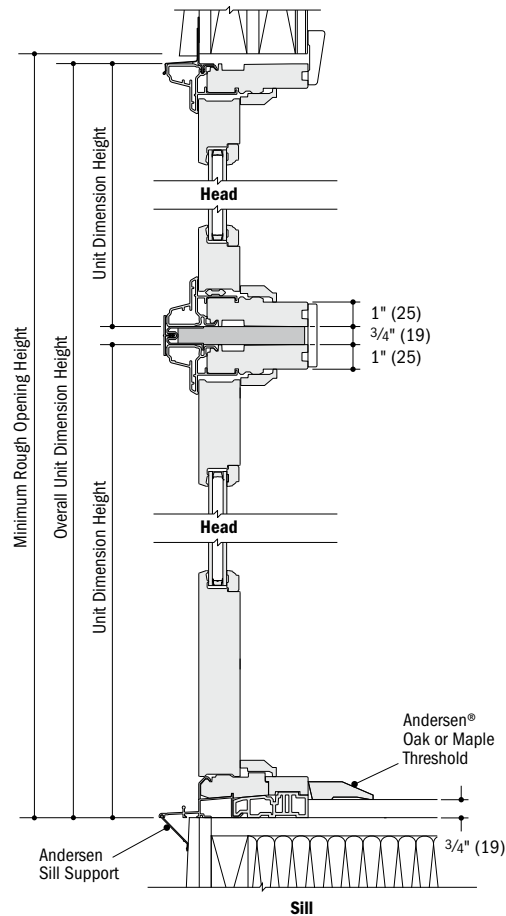

**Vertical Section**  
Frenchwood Patio Door Transom over Frenchwood Patio Door Sidelight

**For more joining information, see the combination designs section starting on page 181.**

- \* Light-colored areas are parts included with patio door sidelights/transoms or doors. Dark-colored areas are additional Andersen® parts required to complete patio door sidelights/transoms or doors assembly as shown.
- \* **Rough openings may need to be increased to allow for use of building wraps, flashing, sill panning, brackets, fasteners or other items. See installation information on pages 210-211.**
- \* Details are for illustration only and are not intended to represent product installation methods or materials. Refer to product installation guides at [andersenwindows.com](http://andersenwindows.com).
- \* Dimensions in parentheses are in millimeters.

# COMPLEMENTARY CURVED TOP PATIO DOORS

400 Series  
Complementary  
Curved Top Patio Doors

## SECTION REFERENCE

### Springline™ Hinged Inswing & Outswing Patio Doors

Dimensions & Specifications ..... 165  
Door Details ..... 166-167

### Arch Hinged Inswing & Outswing Patio Doors

Dimensions & Specifications ..... 168-170  
Sidelight Details & Joining Details ..... 170  
Door Details ..... 171-172

Product Performance ..... 194

### CUSTOM SIZING

in 1/8" (3) increments



Dimensions in parentheses are in millimeters.

# COMPLEMENTARY CURVED TOP PATIO DOORS

## FEATURES

### Frame

**A** Heavy-duty extruded aluminum cladding protects the frame exterior, providing low-maintenance durability. Standard cladding finish meets AAMA 2604 specification. An optional finish that meets the AAMA 2605 specification is also available.

Installation flange extends 1 1/2" (38) around three sides of the unit to help properly position the unit in the opening. Installation clips are standard for increased structural anchoring to building members. Mounted around the frame perimeter, the clips rotate into position and can be bent into place against the framing members to suit all jamb conditions.

**B** Wood frame members are treated with a water-repellent wood preservative for long-lasting protection and performance. Radii are made of laminated continuous veneers. Lineal components are engineered wood with a pine core.

**C** Extruded aluminum sill is thermally broken and available in painted bronze or gray finish. Innovative sill design provides superior water management. Standard outswing sills have an oak cap. Maple or mahogany\* is optional. Inswing sills have an interior wood trim strip to match the interior finish.

**D** One-piece compression weatherstrip at the frame sides and head protects against air and water infiltration. Flexible thermoplastic sweep is featured at the bottom of the panel on inswing units. Outswing doors also feature a polypropylene rain skirt at the panel sides and top for added protection.

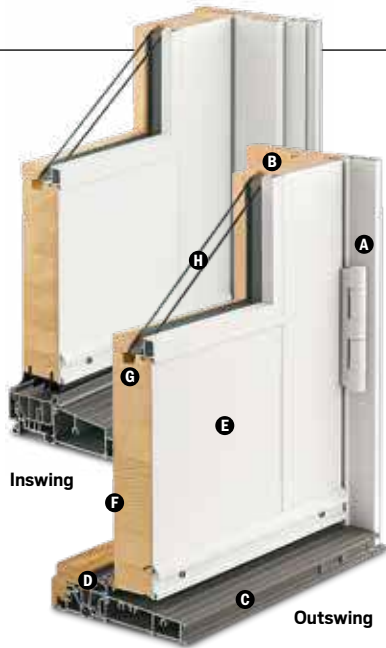

### Panel

**E** Heavy-duty extruded aluminum cladding protects the panel exterior, providing low-maintenance durability.

**F** Panel interior surfaces are unfinished wood veneers. Available species are pine, oak and maple.

**G** Silicone glazing bead combined with two-sided silicone tape provides superior weathertightness.

### Glass

**H** High-Performance glass options include:

- Low-E4® tempered glass
- Low-E4 HeatLock® tempered glass
- Low-E4 Sun tempered glass
- Low-E4 SmartSun™ tempered glass
- Low-E4 SmartSun HeatLock tempered glass

Additional glass options are available. Contact your Andersen supplier.

A removable translucent film helps shield the glass from damage during delivery and construction and simplifies finishing at the jobsite.

### Operation

Inswing and outswing units are available. Choose left-hinged, right-hinged or stationary as viewed from the exterior.

### Hardware

#### Multi-Point Locking System/Expanded Offering

The complementary hinged patio door has a multi-point locking system with a hook bolt above and below the center deadbolt. This system provides a weathertight seal and enhanced security. Mix-and-match style and finish options are available to get just the right look inside and out. For hardware style and finish options, see pages 10-11.

#### Hinges

Ball-bearing hinges are standard on outswing patio doors and are available in finishes that coordinate with hardware trim sets. old dust finish is standard on wood interior doors. For units with a prefinished white interior, white finish hinges are standard. Also available in finishes that coordinate with hardware.

Adjustable hinges are standard on inswing patio doors and have ball-bearing pivots for smooth, frictionless movement. Features easy horizontal and vertical adjustment, plus quick-release feature for easy panel removal. This release feature is ideal for transporting large units up stairs or to other hard-to-reach areas.

#### Hardware Options†

See pages 10-11 for hardware styles and finish options, including FSB® hardware.

## ACCESSORIES Sold Separately

### Frame

#### Extension Jamb

Inswing and outswing standard jamb depth is 4 3/16" (116). Inswing is also available in a 6 3/16" (167) jamb depth. Interior extension jambs are available in 1/16" (1.5) increments between 4 3/16" (116) and 7 1/8" (181). Additional dimensions are available. Contact your Andersen supplier for more information.

Interior extension jambs on inswing units will restrict the full opening of the door.

#### Casings



Curved interior casings are available in the same profiles as other Andersen® products. Curved exterior aluminum and wood casings are available in matching radii and a variety of profiles.

### Hardware

#### Exterior Keyed Lock



A six-pin key cylinder lock is available for all patio doors in styles and finishes that coordinate with hardware. This lock allows the door to be locked and unlocked from the exterior.

### Grilles

Grilles are available in a variety of configurations and widths.

### Art Glass

Decorative insulated art glass designs are available.

## EXTERIOR

Custom colors available.



White Canvas Sandtone Terratone Forest Green Dark Bronze



Dove Gray Prairie Grass Red Rock Cocoa Bean Black

## INTERIOR



Pine Maple Oak White



Dark Bronze Black

Painted options available on pine only. Additional interior wood species and colors are available. Naturally occurring variations in grain, color and texture of wood make each door one of a kind. All wood interiors are unfinished unless a prefinished option is specified.

\* Visit [andersenwindows.com/warranty](http://andersenwindows.com/warranty) for details.

\*\* Actual wood species is either Sapele or Sipo, both non-endangered species grown in Africa, with color and characteristics similar to Central American mahoganies.

† Hardware sold separately.

“FSB” is a registered trademark of Franz Schneider Brakel GmbH & Co.

Dimensions in parentheses are in millimeters.

Printing limitations prevent exact duplication of colors. See your Andersen supplier for actual color samples.



**1** AHISDxx80

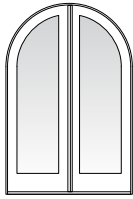

**1** AHISDxx80AP/PA



Custom-size doors are available in 1/8" (3) increments.

Traditional panels are standard. Custom-designed and 3/4-light panels are also available. Stationary doors are also available (i.e. 3180S or 4080SS). Add AHISD to "Door Number" listed in table (i.e. AHISD3180).

**Complementary Springline™ Hinged Inswing Patio Door Dimensions and Specifications**

Door Number	Number of Panels Open*	Door Dimensions				Min. Rough Opening		Clear Opening Area Sq. Ft./ (m <sup>2</sup> )	Clear Opening Maximums			Glass Area Sq. Ft./ (m <sup>2</sup> )	Vent Area Sq. Ft./ (m <sup>2</sup> )	Overall Door Area Sq. Ft./ (m <sup>2</sup> )
		Radius Inches/(mm)	Side Height Inches/(mm)	Width Inches/(mm)	Height Inches/(mm)	Width Inches/(mm)	Height Inches/(mm)		90° Open Position Width Inches/(mm)	Full Open Position Width Inches/(mm)	Height Inches/(mm)			
3180	1	18" (457)	77 1/2" (1969)	35 15/16" (913)	95 1/2" (2426)	37" (940)	96" (2438)	17.26 (1.60)	30 7/8" (784)	32 13/16" (833)	75 3/4" (1924)	13.28 (1.23)	20.27 (1.88)	22.88 (2.13)
3380	1	19" (483)	76 1/2" (1943)	37 15/16" (964)	95 1/2" (2426)	39" (991)	96" (2438)	18.07 (1.68)	32 7/8" (835)	34 13/16" (884)	74 3/4" (1899)	14.31 (1.33)	21.45 (1.99)	24.09 (2.24)
4080	2	23 5/8" (600)	71 7/8" (1826)	47 1/4" (1200)	95 1/2" (2426)	48" (1219)	96" (2438)	21.34 (1.98)	39 15/16" (1014)	43 13/16" (1113)	70 7/8" (1781)	13.27 (1.23)	26.72 (2.48)	29.67 (2.76)
4080	1	23 5/8" (600)	71 7/8" (1826)	47 1/4" (1200)	95 1/2" (2426)	48" (1219)	96" (2438)	10.17 (0.94)	18 15/16" (481)	20 7/8" (530)	70 7/8" (1781)	13.27 (1.23)	11.72 (1.09)	29.67 (2.76)
5080	2	29 5/8" (752)	65 7/8" (1673)	59 1/4" (1505)	95 1/2" (2426)	60" (1524)	96" (2438)	24.85 (2.31)	51 15/16" (1319)	55 13/16" (1418)	64 7/8" (1629)	19.14 (1.78)	33.54 (3.12)	36.68 (3.41)
5080	1	29 5/8" (752)	65 7/8" (1673)	59 1/4" (1505)	95 1/2" (2426)	60" (1524)	96" (2438)	11.97 (1.11)	24 15/16" (633)	26 7/8" (683)	64 7/8" (1629)	19.14 (1.78)	14.53 (1.35)	36.68 (3.41)
5480	2	31 5/8" (803)	63 7/8" (1622)	63 1/4" (1607)	95 1/2" (2426)	64" (1626)	96" (2438)	25.80 (2.40)	55 15/16" (1421)	59 13/16" (1519)	62 1/8" (1578)	21.05 (1.96)	35.77 (3.32)	38.97 (3.62)
5480	1	31 5/8" (803)	63 7/8" (1622)	63 1/4" (1607)	95 1/2" (2426)	64" (1626)	96" (2438)	12.46 (1.16)	26 15/16" (684)	28 7/8" (733)	62 1/8" (1578)	21.05 (1.96)	15.45 (1.44)	38.97 (3.62)
6080	2	35 5/8" (905)	59 7/8" (1521)	71 1/4" (1810)	95 1/2" (2426)	72" (1829)	96" (2438)	27.37 (2.54)	63 15/16" (1624)	67 13/16" (1722)	58 1/8" (1476)	24.79 (2.30)	40.15 (3.73)	43.47 (4.04)
6080	1	35 5/8" (905)	59 7/8" (1521)	71 1/4" (1810)	95 1/2" (2426)	72" (1829)	96" (2438)	13.27 (1.23)	30 15/16" (786)	32 7/8" (835)	58 1/8" (1476)	24.79 (2.30)	17.24 (1.60)	43.47 (4.04)
6480	2	37 5/8" (956)	57 7/8" (1470)	75 1/4" (1911)	95 1/2" (2426)	76" (1930)	96" (2438)	27.99 (2.60)	67 15/16" (1726)	71 13/16" (1824)	56 1/8" (1426)	26.63 (2.47)	42.30 (3.93)	45.69 (4.24)
6480	1	37 5/8" (956)	57 7/8" (1470)	75 1/4" (1911)	95 1/2" (2426)	76" (1930)	96" (2438)	13.59 (1.26)	32 15/16" (837)	34 7/8" (886)	56 1/8" (1426)	26.63 (2.47)	19.84 (1.84)	45.69 (4.24)

- \*"Door Dimension" always refers to outside frame to frame dimension.
- \*"Minimum Rough Opening" dimensions may need to be increased to allow for use of building wraps, flashing, sill panning, brackets, fasteners or other items. See pages 210-211 for more details.
- \*Dimensions in parentheses are in millimeters or square meters.
- \*For two-panel patio doors with one panel open, clear opening is based on active panel being open and passive panel being closed.



**1** AOSDxx80

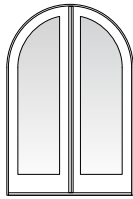

**1** AOSDxx80AP/PA



Custom-size doors are available in 1/8" (3) increments.

Traditional panels are standard. Custom-designed and 3/4-light panels are also available. Stationary doors are also available (i.e. 3180S or 4080SS). Add AOSD to "Door Number" listed in table (i.e. AOSD3180).

**Complementary Springline™ Hinged Outswing Patio Door Dimensions and Specifications**

Door Number	Number of Panels Open*	Door Dimensions				Min. Rough Opening		Clear Opening Area Sq. Ft./ (m <sup>2</sup> )	Clear Opening Maximums			Glass Area Sq. Ft./ (m <sup>2</sup> )	Vent Area Sq. Ft./ (m <sup>2</sup> )	Overall Door Area Sq. Ft./ (m <sup>2</sup> )
		Radius Inches/(mm)	Side Height Inches/(mm)	Width Inches/(mm)	Height Inches/(mm)	Width Inches/(mm)	Height Inches/(mm)		90° Open Position Width Inches/(mm)	Full Open Position Width Inches/(mm)	Height Inches/(mm)			
3180	1	18" (457)	77 1/2" (1969)	35 15/16" (913)	95 1/2" (2426)	37" (940)	96" (2438)	17.52 (1.63)	31 3/8" (797)	33 5/16" (846)	75 3/4" (1924)	13.28 (1.23)	20.53 (1.91)	22.88 (2.13)
3380	1	19" (483)	76 1/2" (1943)	37 15/16" (964)	95 1/2" (2426)	39" (991)	96" (2438)	18.33 (1.70)	33 3/8" (848)	35 5/16" (897)	74 3/4" (1899)	14.31 (1.33)	21.71 (2.02)	24.09 (2.24)
4080	2	23 5/8" (600)	71 7/8" (1826)	47 1/4" (1200)	95 1/2" (2426)	48" (1219)	96" (2438)	21.73 (2.02)	40 11/16" (1033)	44 5/8" (1133)	70 7/8" (1781)	13.27 (1.23)	27.12 (2.52)	29.67 (2.76)
4080	1	23 5/8" (600)	71 7/8" (1826)	47 1/4" (1200)	95 1/2" (2426)	48" (1219)	96" (2438)	10.35 (0.96)	19 1/4" (489)	21 1/4" (540)	70 7/8" (1781)	13.27 (1.23)	11.72 (1.09)	29.67 (2.76)
5080	2	29 5/8" (752)	65 7/8" (1673)	59 1/4" (1505)	95 1/2" (2426)	60" (1524)	96" (2438)	25.22 (2.34)	52 11/16" (1338)	56 5/8" (1438)	64 7/8" (1629)	19.14 (1.78)	33.90 (3.15)	36.68 (3.41)
5080	1	29 5/8" (752)	65 7/8" (1673)	59 1/4" (1505)	95 1/2" (2426)	60" (1524)	96" (2438)	12.13 (1.13)	25 1/4" (641)	27 1/4" (692)	64 7/8" (1629)	19.14 (1.78)	14.53 (1.35)	36.68 (3.41)
5480	2	31 5/8" (803)	63 7/8" (1622)	63 1/4" (1607)	95 1/2" (2426)	64" (1626)	96" (2438)	26.16 (2.43)	56 11/16" (1440)	60 5/8" (1540)	62 1/8" (1578)	21.05 (1.96)	36.12 (3.36)	38.97 (3.62)
5480	1	31 5/8" (803)	63 7/8" (1622)	63 1/4" (1607)	95 1/2" (2426)	64" (1626)	96" (2438)	12.62 (1.17)	27 1/4" (692)	29 1/4" (743)	62 1/8" (1578)	21.05 (1.96)	15.45 (1.44)	38.97 (3.62)
6080	2	35 5/8" (905)	59 7/8" (1521)	71 1/4" (1810)	95 1/2" (2426)	72" (1829)	96" (2438)	27.70 (2.57)	64 11/16" (1643)	68 5/8" (1743)	58 1/8" (1476)	24.79 (2.30)	40.48 (3.76)	43.47 (4.04)
6080	1	35 5/8" (905)	59 7/8" (1521)	71 1/4" (1810)	95 1/2" (2426)	72" (1829)	96" (2438)	13.42 (1.25)	31 1/4" (794)	33 1/4" (845)	58 1/8" (1476)	24.79 (2.30)	17.24 (1.60)	43.47 (4.04)
6480	2	37 5/8" (956)	57 7/8" (1470)	75 1/4" (1911)	95 1/2" (2426)	76" (1930)	96" (2438)	28.31 (2.63)	68 11/16" (1745)	72 5/8" (1845)	56 1/8" (1426)	26.63 (2.47)	42.62 (3.96)	45.69 (4.24)
6480	1	37 5/8" (956)	57 7/8" (1470)	75 1/4" (1911)	95 1/2" (2426)	76" (1930)	96" (2438)	13.74 (1.28)	33 1/4" (845)	35 1/4" (895)	56 1/8" (1426)	26.63 (2.47)	19.84 (1.84)	45.69 (4.24)

- \*"Door Dimension" always refers to outside frame to frame dimension.
- \*"Minimum Rough Opening" dimensions may need to be increased to allow for use of building wraps, flashing, sill panning, brackets, fasteners or other items. See pages 210-211 for more details.
- \*Dimensions in parentheses are in millimeters or square meters.
- \*For two-panel patio doors with one panel open, clear opening is based on active panel being open and passive panel being closed.

# COMPLEMENTARY CURVED TOP PATIO DOORS

## Complementary Springline™ Hinged Inswing Patio Door Details – 4 9/16" (116) Jamb Depth

Scale 1 1/2" (38) = 1'-0" (305) – 1:8

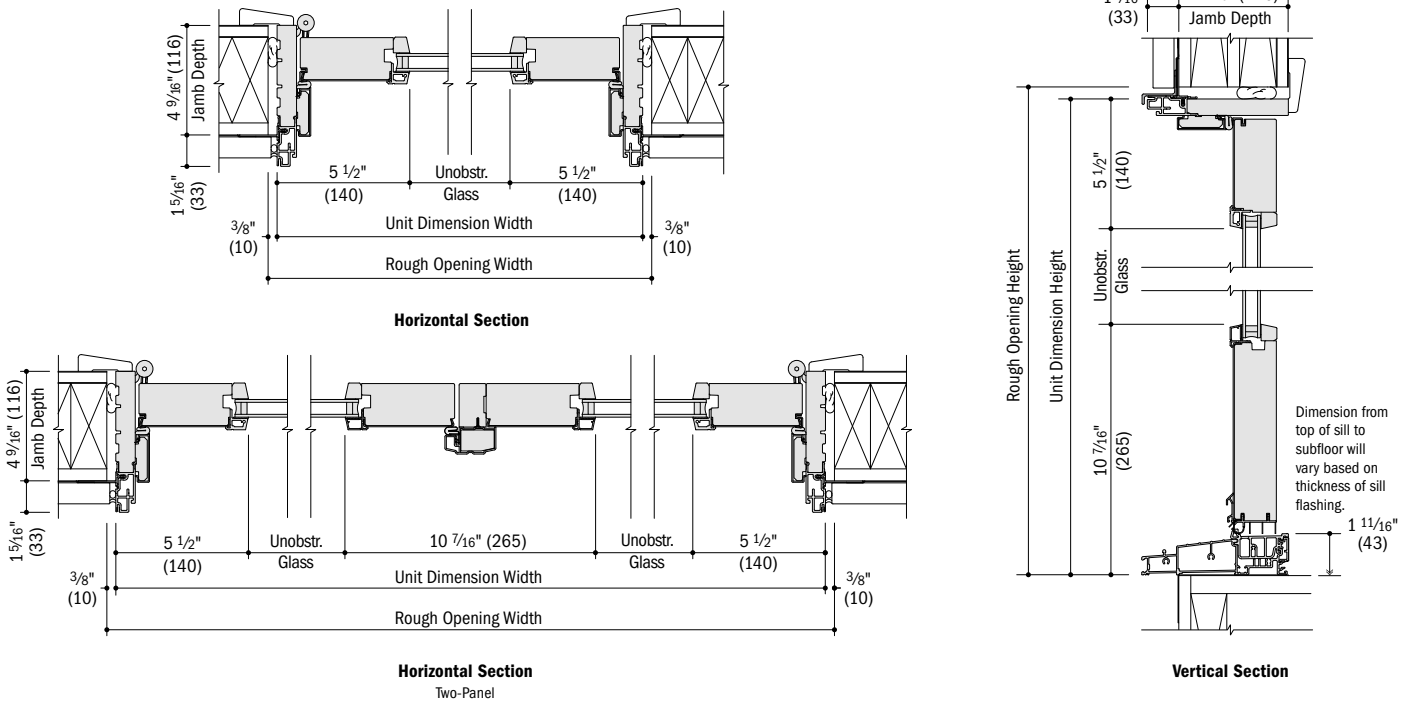

## Complementary Springline™ Hinged Inswing Patio Door Details – 6 9/16" (167) Jamb Depth

Scale 1 1/2" (38) = 1'-0" (305) – 1:8

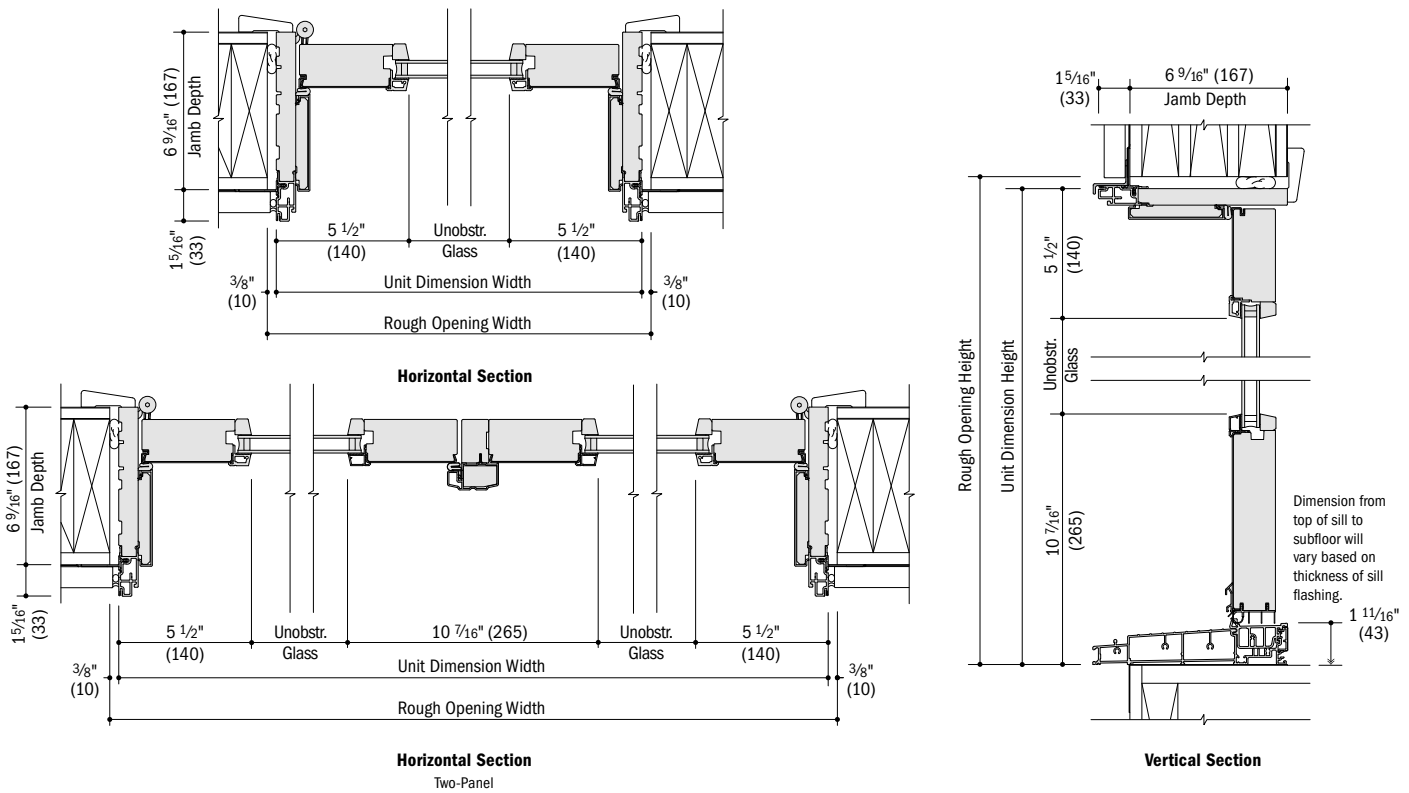

- 4 9/16" (116) and 6 9/16" (167) jamb depth measurements are from back side of installation flange.
- Light-colored areas are parts included with door. Dark-colored areas are additional Andersen™ parts required to complete door assembly as shown.
- **Rough openings may need to be increased to allow for use of building wraps, flashing, sill panning, brackets, fasteners or other items. See installation information on pages 210-211.**
- Details are for illustration only and are not intended to represent product installation methods or materials. Refer to product installation guides at [andersenwindows.com](http://andersenwindows.com).
- Dimensions in parentheses are in millimeters.

**Complementary Springline™ Hinged Outswing Patio Door Details – 4 9/16" (116) Jamb Depth**

Scale 1 1/2" (38) = 1'-0" (305) – 1:8

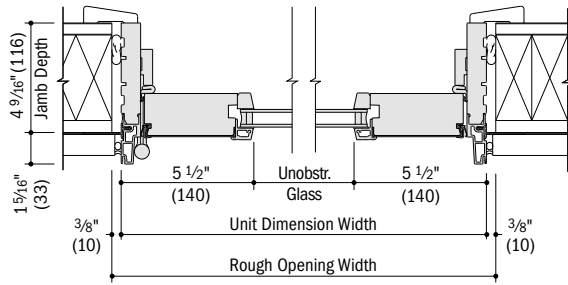

**Horizontal Section**

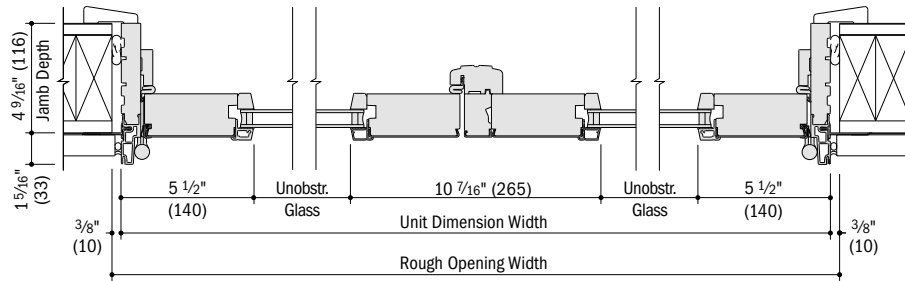

**Horizontal Section**  
 Two-Panel

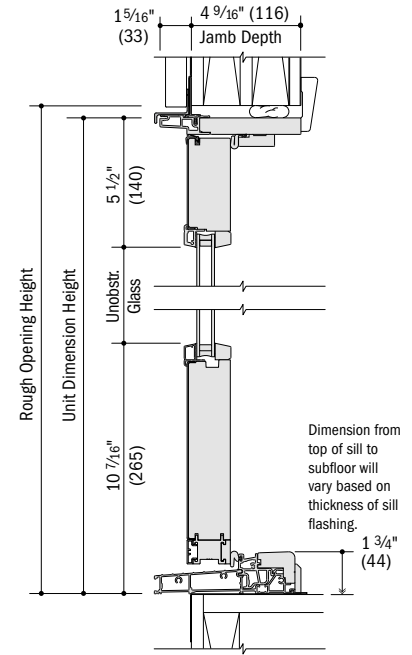

**Vertical Section**

- 4 9/16" (116) jamb depth measurements are from back side of installation flange.
- Light-colored areas are parts included with door. Dark-colored areas are additional Andersen® parts required to complete door assembly as shown.
- **Rough openings may need to be increased to allow for use of building wraps, flashing, sill panning, brackets, fasteners or other items. See installation information on pages 210-211.**
- Details are for illustration only and are not intended to represent product installation methods or materials. Refer to product installation guides at andersenwindows.com.
- Dimensions in parentheses are in millimeters.

# COMPLEMENTARY CURVED TOP PATIO DOORS

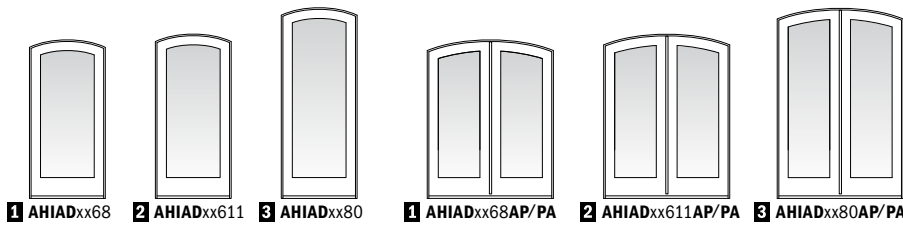

Custom-size doors are available in 1/8" (3) increments. Traditional panels are standard. Custom-designed and 3/4-light panels are also available. Stationary doors are also available (i.e. 2168S or 4068SS). Add AHIA D to "Door Number" listed in table (i.e. AHIA D2168).

## Complementary Arch Hinged Inswing Patio Door Dimensions and Specifications

Door Number	Number of Panels Open*	Door Dimensions				Min. Rough Opening		Clear Opening Maximums				Glass Area Sq. Ft./ (m <sup>2</sup> )	Vent Area Sq. Ft./ (m <sup>2</sup> )	Overall Door Area Sq. Ft./ (m <sup>2</sup> )
		Radius Inches/(mm)	Side Height Inches/(mm)	Width Inches/(mm)	Height Inches/(mm)	Width Inches/(mm)	Height Inches/(mm)	Clear Opening Area Sq. Ft./ (m <sup>2</sup> )	90° Open Position Width Inches/(mm)	Full Open Position Width Inches/(mm)	Height Inches/(mm)			
2168	1	36" (914)	77 7/16" (1967)	23 15/16" (608)	79 1/2" (2019)	25" (635)	80" (2032)	10.79 (1.00)	18 7/8" (479)	20 13/16" (529)	74 11/16" (1897)	5.66 (0.53)	12.46 (1.16)	14.49 (1.35)
2768	1	48" (1219)	77 7/16" (1959)	29 15/16" (760)	79 1/2" (2019)	31" (787)	80" (2032)	13.84 (1.29)	24 7/8" (632)	26 13/16" (681)	74 5/16" (1888)	8.28 (0.77)	15.70 (1.46)	17.85 (1.66)
2968	1	48" (1219)	76 3/4" (1949)	31 15/16" (811)	79 1/2" (2019)	33" (838)	80" (2032)	14.81 (1.38)	26 7/8" (683)	28 13/16" (732)	74" (1880)	9.15 (0.85)	16.77 (1.56)	18.95 (1.76)
3168	1	48" (1219)	76" (1930)	35 15/16" (913)	79 1/2" (2019)	37" (940)	80" (2032)	16.71 (1.55)	30 7/8" (784)	32 13/16" (833)	73 5/16" (1862)	10.87 (1.01)	18.88 (1.75)	21.13 (1.96)
3368	1	48" (1219)	75 5/8" (1921)	37 15/16" (964)	79 1/2" (2019)	39" (991)	80" (2032)	17.86 (1.66)	32 7/8" (835)	34 13/16" (884)	73 7/8" (1876)	11.72 (1.09)	22.01 (2.04)	24.36 (2.26)
21611	1	36" (914)	80 5/16" (2040)	23 15/16" (608)	82 3/8" (2092)	25" (635)	83" (2108)	11.21 (1.04)	18 7/8" (479)	20 13/16" (529)	77 9/16" (1970)	5.93 (0.55)	14.39 (1.34)	16.65 (1.55)
27611	1	48" (1219)	80" (2032)	29 15/16" (760)	82 3/8" (2092)	31" (787)	83" (2108)	14.37 (1.33)	24 7/8" (632)	26 13/16" (681)	77 3/16" (1961)	8.68 (0.81)	18.17 (1.69)	20.55 (1.91)
29611	1	48" (1219)	79 5/8" (2022)	31 15/16" (811)	82 3/8" (2092)	33" (838)	83" (2108)	15.38 (1.43)	26 7/8" (683)	28 13/16" (732)	76 7/8" (1953)	9.58 (0.89)	19.41 (1.80)	21.83 (2.03)
31611	1	48" (1219)	78 7/8" (2003)	35 15/16" (913)	82 3/8" (2092)	37" (940)	83" (2108)	17.36 (1.61)	30 7/8" (784)	32 13/16" (833)	76 3/16" (1935)	11.39 (1.06)	21.89 (2.03)	24.37 (2.26)
33611	1	48" (1219)	78 1/2" (1994)	37 15/16" (964)	82 3/8" (2092)	39" (991)	83" (2108)	18.55 (1.72)	32 7/8" (835)	34 13/16" (884)	76 3/8" (1949)	12.28 (1.14)	25.19 (2.34)	27.78 (2.58)
2180	1	36" (914)	93 7/16" (2373)	23 15/16" (608)	95 1/2" (2426)	25" (635)	96" (2438)	13.11 (1.22)	18 7/8" (479)	20 13/16" (529)	90 11/16" (2303)	7.09 (0.66)	16.31 (1.52)	18.81 (1.75)
2780	1	48" (1219)	93 1/8" (2365)	29 15/16" (760)	95 1/2" (2426)	31" (787)	96" (2438)	16.82 (1.56)	24 7/8" (632)	26 13/16" (681)	90 5/16" (2294)	10.38 (0.96)	20.63 (1.92)	23.25 (2.16)
2980	1	48" (1219)	92 3/4" (2356)	31 15/16" (811)	95 1/2" (2426)	33" (838)	96" (2438)	18.01 (1.67)	26 7/8" (683)	28 13/16" (732)	90" (2286)	11.47 (1.07)	22.06 (2.05)	24.71 (2.30)
3180	1	48" (1219)	92" (2337)	35 15/16" (913)	95 1/2" (2426)	37" (940)	96" (2438)	20.35 (1.89)	30 7/8" (784)	32 13/16" (833)	89 5/16" (2269)	13.63 (1.27)	24.89 (2.31)	27.62 (2.57)
3380	1	48" (1219)	91 5/8" (2327)	37 15/16" (964)	95 1/2" (2426)	39" (991)	96" (2438)	21.73 (2.02)	32 7/8" (835)	34 13/16" (884)	89 7/8" (2283)	14.71 (1.37)	28.38 (2.64)	31.20 (2.90)
4068	2	48" (1219)	73 5/16" (1862)	47 1/4" (1200)	79 1/2" (2019)	48" (1219)	80" (2032)	21.56 (2.00)	39 15/16" (1014)	43 13/16" (1113)	70 7/8" (1800)	10.93 (1.02)	25.61 (2.38)	28.07 (2.61)
4068	1	48" (1219)	73 5/16" (1862)	47 1/4" (1200)	79 1/2" (2019)	48" (1219)	80" (2032)	10.27 (0.95)	18 15/16" (481)	20 7/8" (530)	70 7/8" (1800)	10.93 (1.02)	12.22 (1.14)	28.07 (2.61)
5068	2	96" (2438)	74 13/16" (1900)	59 1/4" (1505)	79 1/2" (2019)	60" (1524)	80" (2032)	27.95 (2.60)	51 15/16" (1319)	55 13/16" (1418)	72 1/8" (1832)	16.30 (1.51)	32.24 (3.00)	34.97 (3.25)
5068	1	96" (2438)	74 13/16" (1900)	59 1/4" (1505)	79 1/2" (2019)	60" (1524)	80" (2032)	13.46 (1.25)	24 15/16" (633)	26 7/8" (683)	72 1/8" (1832)	16.30 (1.51)	15.54 (1.44)	34.97 (3.25)
5468	2	96" (2438)	74 1/8" (1883)	63 1/4" (1607)	79 1/2" (2019)	64" (1626)	80" (2032)	29.70 (2.76)	55 15/16" (1421)	59 13/16" (1519)	71 1/2" (1816)	17.97 (1.67)	34.29 (3.19)	37.09 (3.45)
5468	1	96" (2438)	74 1/8" (1883)	63 1/4" (1607)	79 1/2" (2019)	64" (1626)	80" (2032)	14.34 (1.33)	26 15/16" (684)	28 7/8" (733)	71 1/2" (1816)	17.97 (1.67)	16.56 (1.54)	37.09 (3.45)
6068	2	96" (2438)	72 5/8" (1845)	71 1/4" (1810)	79 1/2" (2019)	72" (1829)	80" (2032)	32.99 (3.06)	63 15/16" (1624)	67 13/16" (1722)	70 1/16" (1780)	21.25 (1.97)	38.33 (3.56)	41.27 (3.83)
6068	1	96" (2438)	72 5/8" (1845)	71 1/4" (1810)	79 1/2" (2019)	72" (1829)	80" (2032)	16.00 (1.49)	30 15/16" (786)	32 7/8" (835)	70 1/16" (1780)	21.25 (1.97)	18.58 (1.73)	41.27 (3.83)
6468	2	96" (2438)	71 13/16" (1824)	75 1/4" (1911)	79 1/2" (2019)	76" (1930)	80" (2032)	34.53 (3.21)	67 15/16" (1726)	71 13/16" (1824)	69 3/4" (1759)	22.86 (2.12)	44.22 (4.11)	47.36 (4.40)
6468	1	96" (2438)	71 13/16" (1824)	75 1/4" (1911)	79 1/2" (2019)	76" (1930)	80" (2032)	16.77 (1.56)	32 15/16" (837)	34 7/8" (886)	69 3/4" (1759)	22.86 (2.12)	21.53 (2.00)	47.36 (4.40)
40611	2	48" (1219)	76 3/16" (1935)	47 1/4" (1200)	82 3/8" (2092)	48" (1219)	83" (2108)	22.44 (2.08)	39 15/16" (1014)	43 13/16" (1113)	73 3/4" (1873)	11.46 (1.06)	29.64 (2.75)	32.34 (3.00)
40611	1	48" (1219)	76 3/16" (1935)	47 1/4" (1200)	82 3/8" (2092)	48" (1219)	83" (2108)	10.69 (0.99)	18 15/16" (481)	20 7/8" (530)	73 3/4" (1873)	11.46 (1.06)	14.29 (1.33)	32.34 (3.00)
50611	2	96" (2438)	77 11/16" (1973)	59 1/4" (1505)	82 3/8" (2092)	60" (1524)	83" (2108)	29.07 (2.70)	51 15/16" (1319)	55 13/16" (1418)	75" (1905)	17.09 (1.59)	37.35 (3.47)	40.32 (3.75)
50611	1	96" (2438)	77 11/16" (1973)	59 1/4" (1505)	82 3/8" (2092)	60" (1524)	83" (2108)	14.00 (1.30)	24 15/16" (633)	26 7/8" (683)	75" (1905)	17.09 (1.59)	18.15 (1.69)	40.32 (3.75)
54611	2	96" (2438)	77" (1956)	63 1/4" (1607)	82 3/8" (2092)	64" (1626)	83" (2108)	30.89 (2.87)	55 15/16" (1421)	59 13/16" (1519)	74 3/8" (1889)	18.84 (1.75)	39.77 (3.69)	42.80 (3.98)
54611	1	96" (2438)	77" (1956)	63 1/4" (1607)	82 3/8" (2092)	64" (1626)	83" (2108)	14.91 (1.39)	26 15/16" (684)	28 7/8" (733)	74 3/8" (1889)	18.84 (1.75)	19.35 (1.80)	42.80 (3.98)
60611	2	96" (2438)	75 1/2" (1918)	71 1/4" (1810)	82 3/8" (2092)	72" (1829)	83" (2108)	34.35 (3.19)	63 15/16" (1624)	67 13/16" (1722)	72 15/16" (1853)	22.28 (2.07)	44.53 (4.14)	47.71 (4.43)
60611	1	96" (2438)	75 1/2" (1918)	71 1/4" (1810)	82 3/8" (2092)	72" (1829)	83" (2108)	16.65 (1.55)	30 15/16" (786)	32 7/8" (835)	72 15/16" (1853)	22.28 (2.07)	21.74 (2.02)	47.71 (4.43)
64611	2	96" (2438)	74 13/16" (1897)	75 1/4" (1911)	82 3/8" (2092)	76" (1930)	83" (2108)	35.97 (3.34)	67 15/16" (1726)	71 13/16" (1824)	72 1/8" (1832)	23.98 (2.23)	50.78 (4.72)	54.16 (5.03)
64611	1	96" (2438)	74 13/16" (1897)	75 1/4" (1911)	82 3/8" (2092)	76" (1930)	83" (2108)	17.47 (1.62)	32 15/16" (837)	34 7/8" (886)	72 1/8" (1832)	23.98 (2.23)	25.22 (2.34)	54.16 (5.03)
4080	2	48" (1219)	89 5/16" (2269)	47 1/4" (1200)	95 1/2" (2426)	48" (1219)	96" (2438)	26.43 (2.46)	39 15/16" (1014)	43 13/16" (1113)	86 7/8" (2207)	13.76 (1.28)	33.66 (3.13)	36.60 (3.40)
4080	1	48" (1219)	89 5/16" (2269)	47 1/4" (1200)	95 1/2" (2426)	48" (1219)	96" (2438)	12.59 (1.17)	18 15/16" (481)	20 7/8" (530)	86 7/8" (2207)	13.76 (1.28)	14.29 (1.33)	36.60 (3.40)
5080	2	96" (2438)	90 13/16" (2307)	59 1/4" (1505)	95 1/2" (2426)	60" (1524)	96" (2438)	34.16 (3.17)	51 15/16" (1319)	55 13/16" (1418)	88 1/8" (2238)	20.50 (1.90)	42.47 (3.95)	45.67 (4.24)
5080	1	96" (2438)	90 13/16" (2307)	59 1/4" (1505)	95 1/2" (2426)	60" (1524)	96" (2438)	16.45 (1.53)	24 15/16" (633)	26 7/8" (683)	88 1/8" (2238)	20.50 (1.90)	18.15 (1.69)	45.67 (4.24)
5480	2	96" (2438)	90 1/8" (2289)	63 1/4" (1607)	95 1/2" (2426)	64" (1626)	96" (2438)	36.34 (3.38)	55 15/16" (1421)	59 13/16" (1519)	87 1/2" (2223)	22.61 (2.10)	45.24 (4.20)	48.51 (4.51)
5480	1	96" (2438)	90 1/8" (2289)	63 1/4" (1607)	95 1/2" (2426)	64" (1626)	96" (2438)	17.55 (1.63)	26 15/16" (684)	28 7/8" (733)	87 1/2" (2223)	22.61 (2.10)	19.35 (1.80)	48.51 (4.51)
6080	2	96" (2438)	88 5/8" (2251)	71 1/4" (1810)	95 1/2" (2426)	72" (1829)	96" (2438)	40.53 (3.77)	63 15/16" (1624)	67 13/16" (1722)	86 1/16" (2186)	26.78 (2.49)	50.73 (4.71)	54.14 (5.03)
6080	1	96" (2438)	88 5/8" (2251)	71 1/4" (1810)	95 1/2" (2426)	72" (1829)	96" (2438)	19.65 (1.83)	30 15/16" (786)	32 7/8" (835)	86 1/16" (2186)	26.78 (2.49)	21.74 (2.02)	54.14 (5.03)
6480	2	96" (2438)	87 13/16" (2230)	75 1/4" (1911)	95 1/2" (2426)	76" (1930)	96" (2438)	42.51 (3.95)	67 15/16" (1726)	71 13/16" (1824)	85 1/8" (2165)	28.83 (2.68)	57.33 (5.33)	60.95 (5.66)
6480	1	96" (2438)	87 13/16" (2230)	75 1/4" (1911)	95 1/2" (2426)	76" (1930)	96" (2438)	20.65 (1.92)	32 15/16" (837)	34 7/8" (886)	85 1/4" (2165)	28.83 (2.68)	25.22 (2.34)	60.95 (5.66)

\* "Door Dimension" always refers to outside frame to frame dimension.  
 \* "Minimum Rough Opening" dimensions may need to be increased to allow for use of building wraps, flashing, sill panning, brackets, fasteners or other items. See pages 210-211 for more details.  
 \* Dimensions in parentheses are in millimeters or square meters.  
 \* For two-panel patio doors with one panel open, clear opening is based on active panel being open and passive panel being closed.



Custom-size doors are available in 1/8" (3) increments. Traditional panels are standard. Custom-designed and 3/4-light panels are also available. Stationary doors are also available (i.e. 2168S or 4068SS). Add AOAD to "Door Number" listed in table (i.e. AOAD2168).

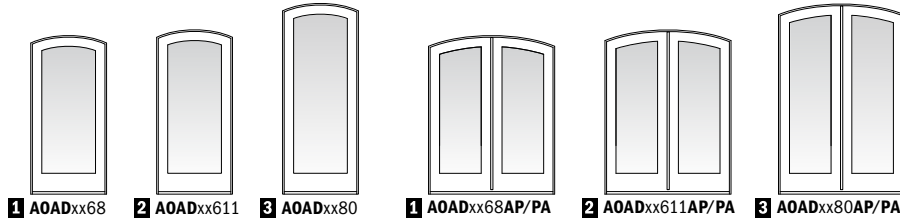

**Complementary Arch Hinged Outswing Patio Door Dimensions and Specifications**

Door Number	Number of Panels Open*	Door Dimensions				Min. Rough Opening		Clear Opening Area Sq. Ft./ (m <sup>2</sup> )	Clear Opening Maximums			Glass Area Sq. Ft./ (m <sup>2</sup> )	Vent Area Sq. Ft./ (m <sup>2</sup> )	Overall Door Area Sq. Ft./ (m <sup>2</sup> )
		Radius Inches/(mm)	Side Height Inches/(mm)	Width Inches/(mm)	Height Inches/(mm)	Width Inches/(mm)	Height Inches/(mm)		90° Open Position Width Inches/(mm)	Full Open Position Width Inches/(mm)	Height Inches/(mm)			
2168	1	36" (914)	77 1/16" (1967)	23 15/16" (608)	79 1/2" (2019)	25" (635)	80" (2032)	11.06 (1.03)	19 3/8" (492)	21 5/16" (541)	74 3/4" (1899)	5.66 (0.53)	12.46 (1.16)	14.49 (1.35)
2768	1	48" (1219)	77 1/8" (1959)	29 15/16" (760)	79 1/2" (2019)	31" (787)	80" (2032)	14.11 (1.31)	25 3/8" (645)	27 5/16" (694)	74 3/8" (1889)	8.28 (0.77)	15.70 (1.46)	17.85 (1.66)
2968	1	48" (1219)	76 3/4" (1949)	31 15/16" (811)	79 1/2" (2019)	33" (838)	80" (2032)	15.08 (1.40)	27 3/8" (695)	29 5/16" (745)	74 1/16" (1881)	9.15 (0.85)	16.77 (1.56)	18.95 (1.76)
3168	1	48" (1219)	76" (1930)	35 15/16" (913)	79 1/2" (2019)	37" (940)	80" (2032)	16.97 (1.58)	31 3/8" (797)	33 3/16" (846)	73 3/8" (1864)	10.87 (1.01)	18.88 (1.75)	21.13 (1.96)
3368	1	48" (1219)	75 5/8" (1921)	37 15/16" (964)	79 1/2" (2019)	39" (991)	80" (2032)	17.90 (1.66)	33 3/8" (848)	35 5/16" (897)	73" (1854)	11.72 (1.09)	22.01 (2.04)	24.36 (2.26)
21611	1	36" (914)	80 5/16" (2040)	23 15/16" (608)	82 3/8" (2092)	25" (635)	83" (2108)	11.49 (1.07)	19 3/8" (492)	21 5/16" (541)	77 5/8" (1972)	5.93 (0.55)	14.39 (1.34)	16.65 (1.55)
27611	1	48" (1219)	80" (2032)	29 15/16" (760)	82 3/8" (2092)	31" (787)	83" (2108)	14.65 (1.36)	25 3/8" (645)	27 5/16" (694)	77 1/4" (1962)	8.68 (0.81)	18.17 (1.69)	20.55 (1.91)
29611	1	48" (1219)	79 5/8" (2022)	31 15/16" (811)	82 3/8" (2092)	33" (838)	83" (2108)	15.66 (1.45)	27 3/8" (695)	29 5/16" (745)	76 15/16" (1954)	9.58 (0.89)	19.41 (1.80)	21.83 (2.03)
31611	1	48" (1219)	78 7/8" (2003)	35 15/16" (913)	82 3/8" (2092)	37" (940)	83" (2108)	17.64 (1.64)	31 3/8" (797)	33 5/16" (846)	76 1/4" (1937)	11.39 (1.06)	21.89 (2.03)	24.37 (2.26)
33611	1	48" (1219)	78 1/4" (1994)	37 15/16" (964)	82 3/8" (2092)	39" (991)	83" (2108)	18.61 (1.73)	33 3/8" (848)	35 5/16" (897)	75 7/8" (1927)	12.28 (1.14)	25.19 (2.34)	27.78 (2.58)
2180	1	36" (914)	93 1/16" (2373)	23 15/16" (608)	95 1/2" (2426)	25" (635)	96" (2438)	13.43 (1.25)	19 3/8" (492)	21 5/16" (541)	90 3/4" (2305)	7.09 (0.66)	16.31 (1.52)	18.81 (1.75)
2780	1	48" (1219)	93 1/8" (2365)	29 15/16" (760)	95 1/2" (2426)	31" (787)	96" (2438)	17.14 (1.59)	25 3/8" (645)	27 5/16" (694)	90 3/8" (2296)	10.38 (0.96)	20.63 (1.92)	23.25 (2.16)
2980	1	48" (1219)	92 3/4" (2356)	31 15/16" (811)	95 1/2" (2426)	33" (838)	96" (2438)	18.33 (1.70)	27 3/8" (695)	29 5/16" (745)	90 1/16" (2288)	11.47 (1.07)	22.06 (2.05)	24.71 (2.30)
3180	1	48" (1219)	92" (2337)	35 15/16" (913)	95 1/2" (2426)	37" (940)	96" (2438)	20.68 (1.92)	31 3/8" (797)	33 3/16" (846)	89 3/8" (2270)	13.63 (1.27)	24.89 (2.31)	27.62 (2.57)
3380	1	48" (1219)	91 5/8" (2327)	37 15/16" (964)	95 1/2" (2426)	39" (991)	96" (2438)	21.83 (2.03)	33 3/8" (848)	35 5/16" (897)	89" (2261)	14.71 (1.37)	28.38 (2.64)	31.20 (2.90)
4068	2	48" (1219)	73 5/16" (1862)	47 1/4" (1200)	79 1/2" (2019)	48" (1219)	80" (2032)	21.93 (2.04)	40 1/16" (1033)	44 5/8" (1133)	70 3/4" (1797)	10.93 (1.02)	25.61 (2.38)	28.07 (2.61)
4068	1	48" (1219)	73 5/16" (1862)	47 1/4" (1200)	79 1/2" (2019)	48" (1219)	80" (2032)	10.44 (0.97)	19 1/4" (489)	21 1/4" (540)	70 3/4" (1797)	10.93 (1.02)	12.22 (1.14)	28.07 (2.61)
5068	2	96" (2438)	74 13/16" (1900)	59 1/4" (1505)	79 1/2" (2019)	60" (1524)	80" (2032)	28.36 (2.63)	52 1/16" (1338)	56 5/8" (1438)	72 1/8" (1832)	16.30 (1.51)	32.24 (3.00)	34.97 (3.25)
5068	1	96" (2438)	74 13/16" (1900)	59 1/4" (1505)	79 1/2" (2019)	60" (1524)	80" (2032)	13.65 (1.27)	25 1/4" (641)	27 1/4" (692)	72 1/8" (1832)	16.30 (1.51)	15.54 (1.44)	34.97 (3.25)
5468	2	96" (2438)	74 1/8" (1883)	63 1/4" (1607)	79 1/2" (2019)	64" (1626)	80" (2032)	30.08 (2.79)	56 11/16" (1440)	60 5/8" (1540)	71 1/16" (1815)	17.97 (1.67)	34.29 (3.19)	37.09 (3.45)
5468	1	96" (2438)	74 1/8" (1883)	63 1/4" (1607)	79 1/2" (2019)	64" (1626)	80" (2032)	14.51 (1.35)	27 1/4" (692)	29 1/4" (743)	71 1/16" (1815)	17.97 (1.67)	16.56 (1.54)	37.09 (3.45)
6068	2	96" (2438)	72 5/8" (1845)	71 1/4" (1810)	79 1/2" (2019)	72" (1829)	80" (2032)	33.36 (3.10)	64 11/16" (1643)	68 5/8" (1743)	70" (1778)	21.25 (1.97)	38.33 (3.56)	41.27 (3.83)
6068	1	96" (2438)	72 5/8" (1845)	71 1/4" (1810)	79 1/2" (2019)	72" (1829)	80" (2032)	16.16 (1.50)	31 1/4" (794)	33 1/4" (845)	70" (1778)	21.25 (1.97)	18.58 (1.73)	41.27 (3.83)
6468	2	96" (2438)	71 13/16" (1824)	75 1/4" (1911)	79 1/2" (2019)	76" (1930)	80" (2032)	34.89 (3.24)	68 11/16" (1745)	72 5/8" (1845)	69 3/16" (1757)	22.86 (2.12)	44.22 (4.11)	47.36 (4.40)
6468	1	96" (2438)	71 13/16" (1824)	75 1/4" (1911)	79 1/2" (2019)	76" (1930)	80" (2032)	16.94 (1.57)	33 1/4" (845)	35 1/4" (895)	69 3/16" (1757)	22.86 (2.12)	21.53 (2.00)	47.36 (4.40)
40611	2	48" (1219)	76 3/16" (1935)	47 1/4" (1200)	82 3/8" (2092)	48" (1219)	83" (2108)	22.82 (2.12)	40 11/16" (1033)	44 5/8" (1133)	73 5/8" (1870)	11.46 (1.06)	29.64 (2.75)	32.34 (3.00)
40611	1	48" (1219)	76 3/16" (1935)	47 1/4" (1200)	82 3/8" (2092)	48" (1219)	83" (2108)	10.86 (1.01)	19 1/4" (489)	21 1/4" (540)	73 5/8" (1870)	11.46 (1.06)	14.29 (1.33)	32.34 (3.00)
50611	2	96" (2438)	77 11/16" (1973)	59 1/4" (1505)	82 3/8" (2092)	60" (1524)	83" (2108)	29.49 (2.74)	52 11/16" (1338)	56 5/8" (1438)	75" (1905)	17.09 (1.59)	37.35 (3.47)	40.32 (3.75)
50611	1	96" (2438)	77 11/16" (1973)	59 1/4" (1505)	82 3/8" (2092)	60" (1524)	83" (2108)	14.19 (1.32)	25 1/4" (641)	27 1/4" (692)	75" (1905)	17.09 (1.59)	18.15 (1.69)	40.32 (3.75)
54611	2	96" (2438)	77" (1956)	63 1/4" (1607)	82 3/8" (2092)	64" (1626)	83" (2108)	31.29 (2.91)	56 11/16" (1440)	60 5/8" (1540)	74 5/16" (1888)	18.84 (1.75)	39.77 (3.69)	42.80 (3.98)
54611	1	96" (2438)	77" (1956)	63 1/4" (1607)	82 3/8" (2092)	64" (1626)	83" (2108)	15.09 (1.40)	27 1/4" (692)	29 1/4" (743)	74 5/16" (1888)	18.84 (1.75)	19.35 (1.80)	42.80 (3.98)
60611	2	96" (2438)	75 1/2" (1918)	71 1/4" (1810)	82 3/8" (2092)	72" (1829)	83" (2108)	34.73 (3.23)	64 11/16" (1643)	68 5/8" (1743)	72 1/8" (1851)	22.28 (2.07)	44.53 (4.14)	47.71 (4.43)
60611	1	96" (2438)	75 1/2" (1918)	71 1/4" (1810)	82 3/8" (2092)	72" (1829)	83" (2108)	16.83 (1.56)	31 1/4" (794)	33 1/4" (845)	72 1/8" (1851)	22.28 (2.07)	21.74 (2.02)	47.71 (4.43)
64611	2	96" (2438)	74 11/16" (1897)	75 1/4" (1911)	82 3/8" (2092)	76" (1930)	83" (2108)	36.34 (3.38)	68 11/16" (1745)	72 5/8" (1845)	72 1/16" (1830)	23.98 (2.23)	50.78 (4.72)	54.16 (5.03)
64611	1	96" (2438)	74 11/16" (1897)	75 1/4" (1911)	82 3/8" (2092)	76" (1930)	83" (2108)	17.64 (1.64)	33 1/4" (845)	35 1/4" (895)	72 1/16" (1830)	23.98 (2.23)	25.22 (2.34)	54.16 (5.03)
4080	2	48" (1219)	89 5/8" (2269)	47 1/4" (1200)	95 1/2" (2426)	48" (1219)	96" (2438)	26.88 (2.50)	40 11/16" (1033)	44 5/8" (1133)	86 3/4" (2203)	13.76 (1.28)	33.66 (3.13)	36.60 (3.40)
4080	1	48" (1219)	89 5/8" (2269)	47 1/4" (1200)	95 1/2" (2426)	48" (1219)	96" (2438)	12.80 (1.19)	19 1/4" (489)	21 1/4" (540)	86 3/4" (2203)	13.76 (1.28)	14.29 (1.33)	36.60 (3.40)
5080	2	96" (2438)	90 13/16" (2307)	59 1/4" (1505)	95 1/2" (2426)	60" (1524)	96" (2438)	34.65 (3.22)	52 11/16" (1338)	56 5/8" (1438)	88 1/8" (2238)	20.50 (1.90)	42.47 (3.95)	45.67 (4.24)
5080	1	96" (2438)	90 13/16" (2307)	59 1/4" (1505)	95 1/2" (2426)	60" (1524)	96" (2438)	16.68 (1.55)	25 1/4" (641)	27 1/4" (692)	88 1/8" (2238)	20.50 (1.90)	18.15 (1.69)	45.67 (4.24)
5480	2	96" (2438)	90 1/8" (2289)	63 1/4" (1607)	95 1/2" (2426)	64" (1626)	96" (2438)	36.81 (3.42)	56 11/16" (1440)	60 5/8" (1540)	87 1/16" (2221)	22.61 (2.10)	45.24 (4.20)	48.51 (4.51)
5480	1	96" (2438)	90 1/8" (2289)	63 1/4" (1607)	95 1/2" (2426)	64" (1626)	96" (2438)	17.76 (1.65)	27 1/4" (692)	29 1/4" (743)	87 1/16" (2221)	22.61 (2.10)	19.35 (1.80)	48.51 (4.51)
6080	2	96" (2438)	88 5/8" (2251)	71 1/4" (1810)	95 1/2" (2426)	72" (1829)	96" (2438)	40.98 (3.81)	64 11/16" (1643)	68 5/8" (1743)	86" (2184)	26.78 (2.49)	50.73 (4.71)	54.14 (5.03)
6080	1	96" (2438)	88 5/8" (2251)	71 1/4" (1810)	95 1/2" (2426)	72" (1829)	96" (2438)	19.86 (1.84)	31 1/4" (794)	33 1/4" (845)	86" (2184)	26.78 (2.49)	21.74 (2.02)	54.14 (5.03)
6480	2	96" (2438)	87 13/16" (2230)	75 1/4" (1911)	95 1/2" (2426)	76" (1930)	96" (2438)	42.96 (3.99)	68 11/16" (1745)	72 5/8" (1845)	85 3/16" (2164)	28.83 (2.68)	57.33 (5.33)	60.95 (5.66)
6480	1	96" (2438)	87 13/16" (2230)	75 1/4" (1911)	95 1/2" (2426)	76" (1930)	96" (2438)	20.85 (1.94)	33 1/4" (845)	35 1/4" (895)	85 3/16" (2164)	28.83 (2.68)	25.22 (2.34)	60.95 (5.66)

\*"Door Dimension" always refers to outside frame to frame dimension.  
 \*\*Minimum Rough Opening" dimensions may need to be increased to allow for use of building wraps, flashing, sill panning, brackets, fasteners or other items. See pages 210-211 for more details.  
 \*Dimensions in parentheses are in millimeters or square meters.  
 \*For two-panel patio doors with one panel open, clear opening is based on active panel being open and passive panel being closed.

# COMPLEMENTARY CURVED TOP PATIO DOORS

## Complementary Arch Patio Door Sidelights

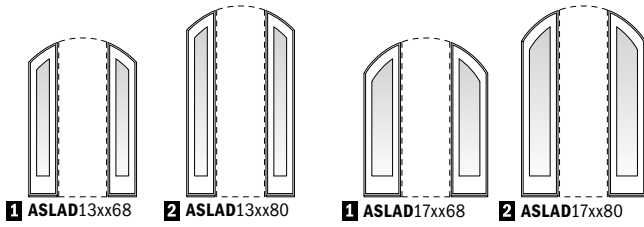

Custom sized in 1/8" (3) increments.

Standard sizes in two widths and heights. Contact your Andersen supplier for sidelight dimensions and specifications. Sash-set arch patio door sidelights, shown, are standard. Direct-set sidelights are available by special order.

## Order Designation Description

Viewed from the exterior.

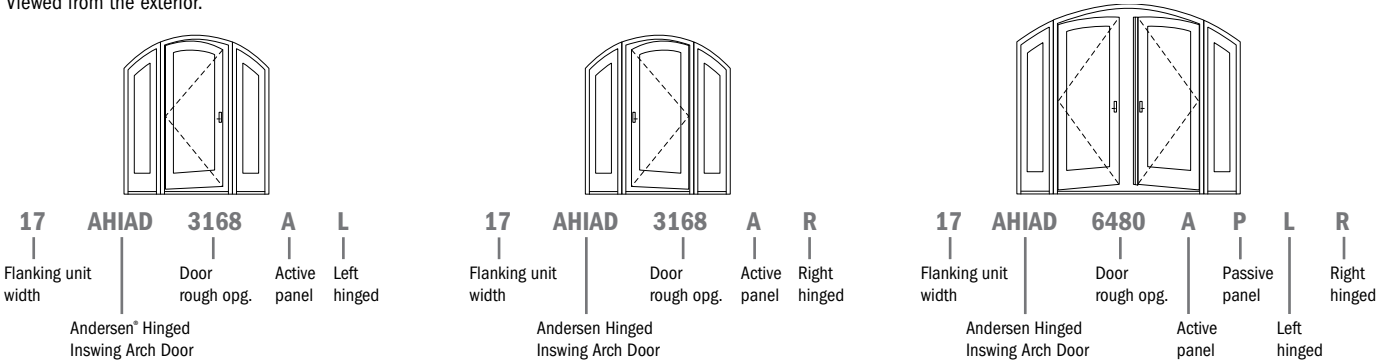

Arch inswing patio doors (AHIA) shown above, for arch outswing patio doors use AOAD. Outswing patio doors open outward to the exterior.

## Complementary Arch Patio Door Sidelight Details

Scale 1 1/2" (38) = 1'-0" (305) – 1:8

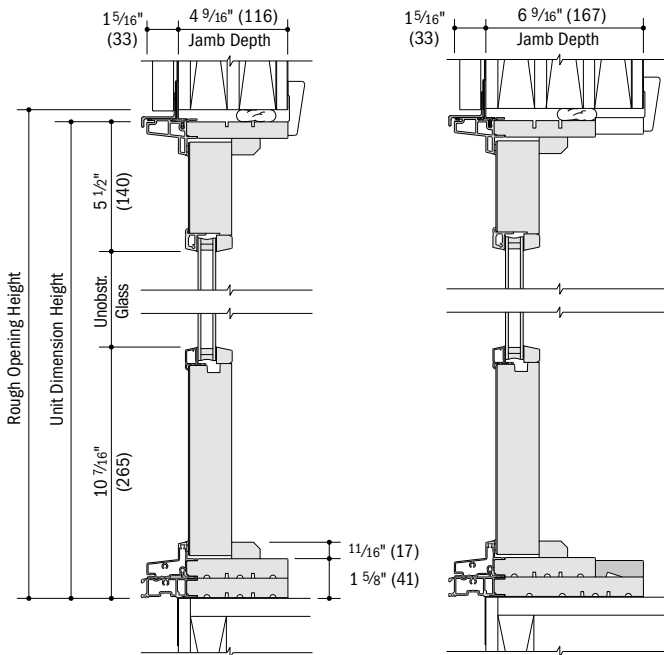

Vertical Sections

## Vertical Joining Details

Scale 1 1/2" (38) = 1'-0" (305) – 1:8

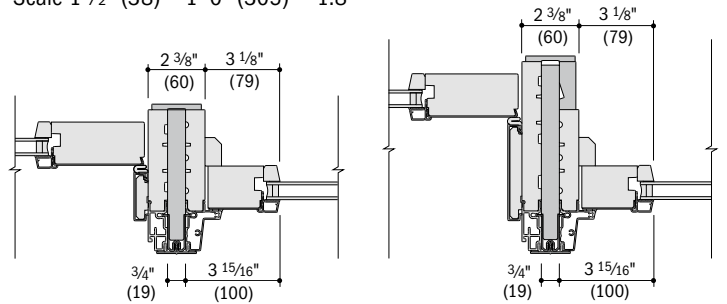

Complementary Arch Inswing Patio Door to Complementary Arch Patio Door Sidelight  
4 9/16" (116) Jamb Depth

Complementary Arch Inswing Patio Door to Complementary Arch Patio Door Sidelight  
6 9/16" (167) Jamb Depth

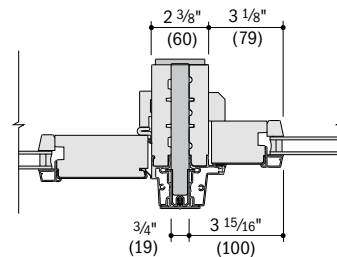

Complementary Arch Outswing Patio Door to Complementary Arch Patio Door Sidelight

- 4 9/16" (116) and 6 9/16" (167) jamb depth measurements are from back side of installation flange.
- Light-colored areas are parts included with window and/or door. Dark-colored areas are additional Andersen® parts required to complete window and/or door assembly as shown.
- **Rough openings may need to be increased to allow for use of building wraps, flashing, sill panning, brackets, fasteners or other items. See installation information on pages 210-211.**
- Details are for illustration only and are not intended to represent product installation methods or materials. Refer to product installation guides at andersenwindows.com.
- Dimensions in parentheses are in millimeters.

**Complementary Arch Hinged Inswing Patio Door Details – 4 9/16" (116) Jamb Depth**

Scale 1 1/2" (38) = 1'-0" (305) – 1:8

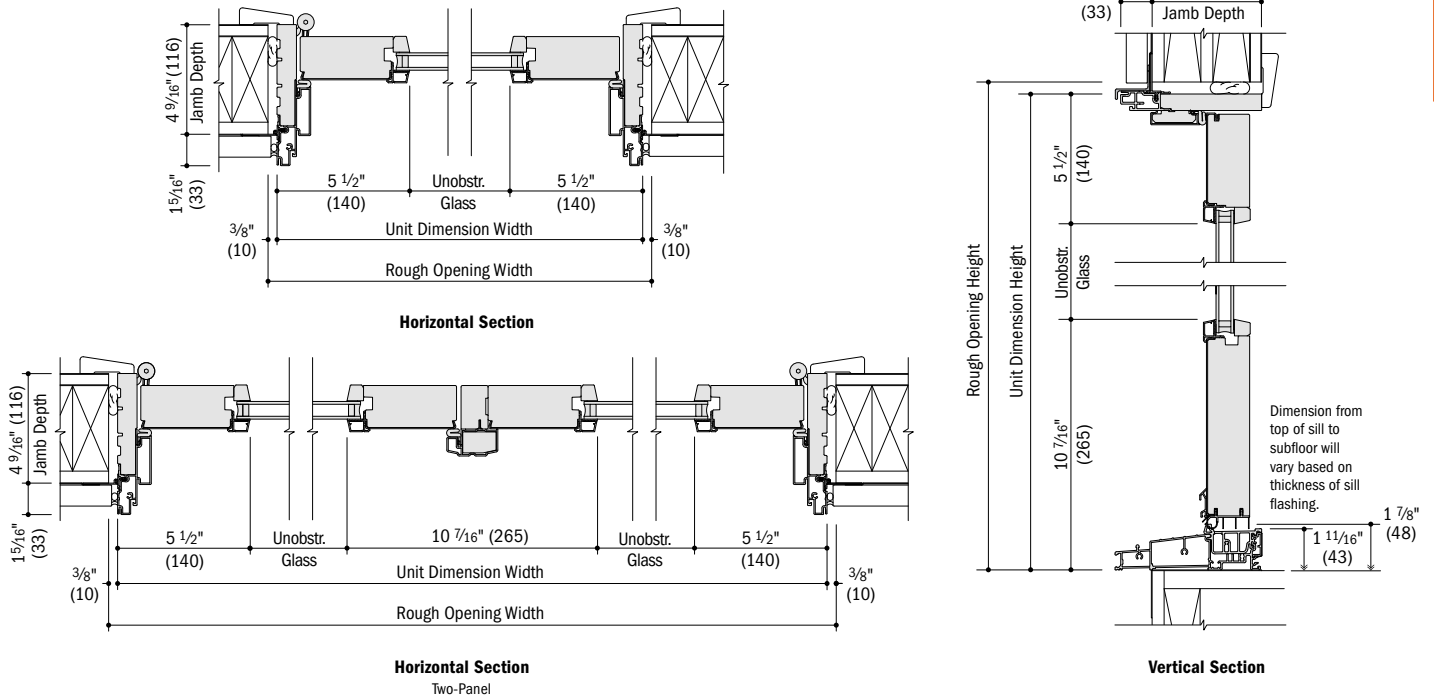

**Complementary Arch Hinged Inswing Patio Door Details – 6 9/16" (167) Jamb Depth**

Scale 1 1/2" (38) = 1'-0" (305) – 1:8

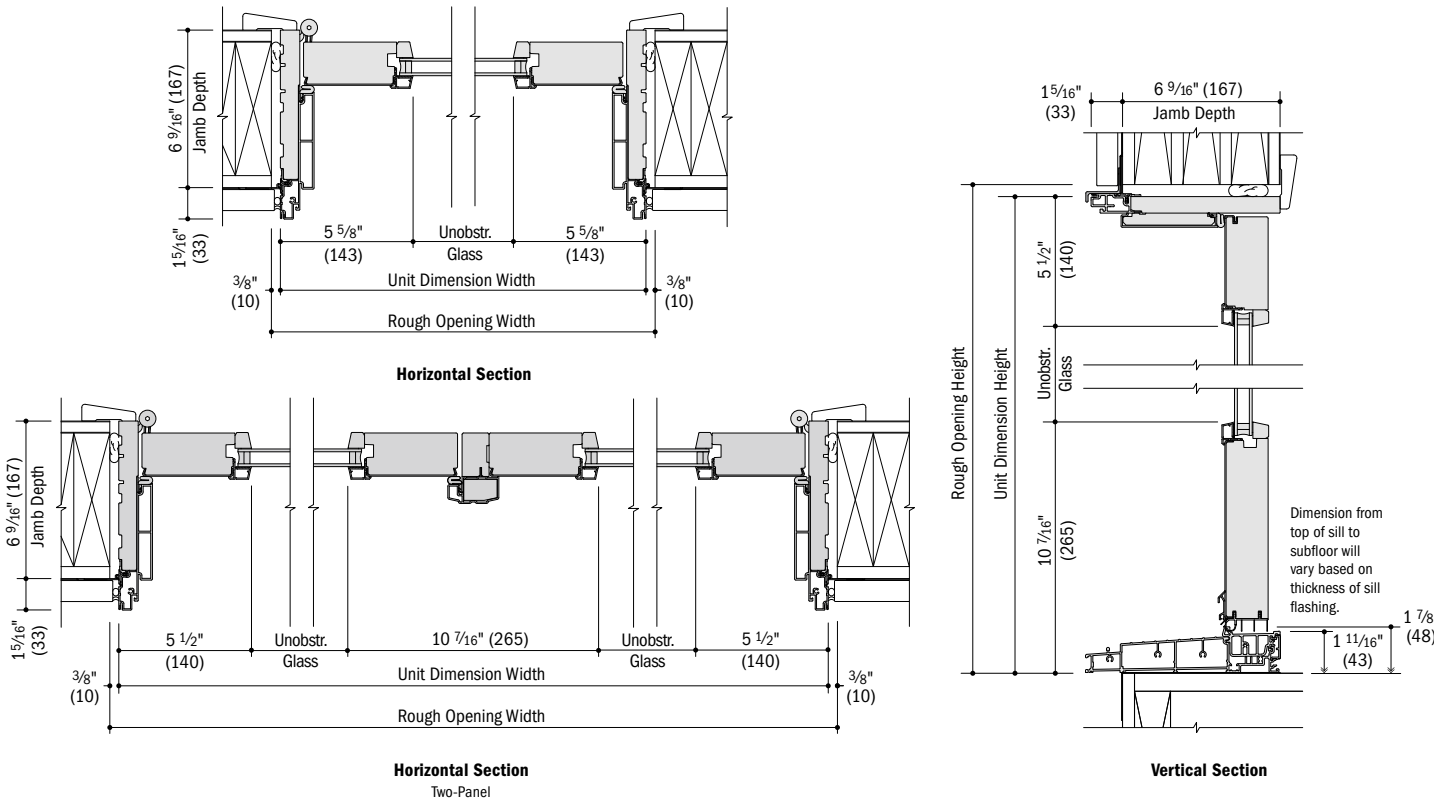

- 4 9/16" (116) and 6 9/16" (167) jamb depth measurements are from back side of installation flange.
- Light-colored areas are parts included with door. Dark-colored areas are additional Andersen® parts required to complete door assembly as shown.
- **Rough openings may need to be increased to allow for use of building wraps, flashing, sill panning, brackets, fasteners or other items. See installation information on pages 210-211.**
- Details are for illustration only and are not intended to represent product installation methods or materials. Refer to product installation guides at andersenwindows.com.
- Dimensions in parentheses are in millimeters.

# COMPLEMENTARY CURVED TOP PATIO DOORS

## Complementary Arch Outswing Patio Door Details – 4 9/16" (116) Jamb Depth

Scale 1 1/2" (38) = 1'-0" (305) – 1:8

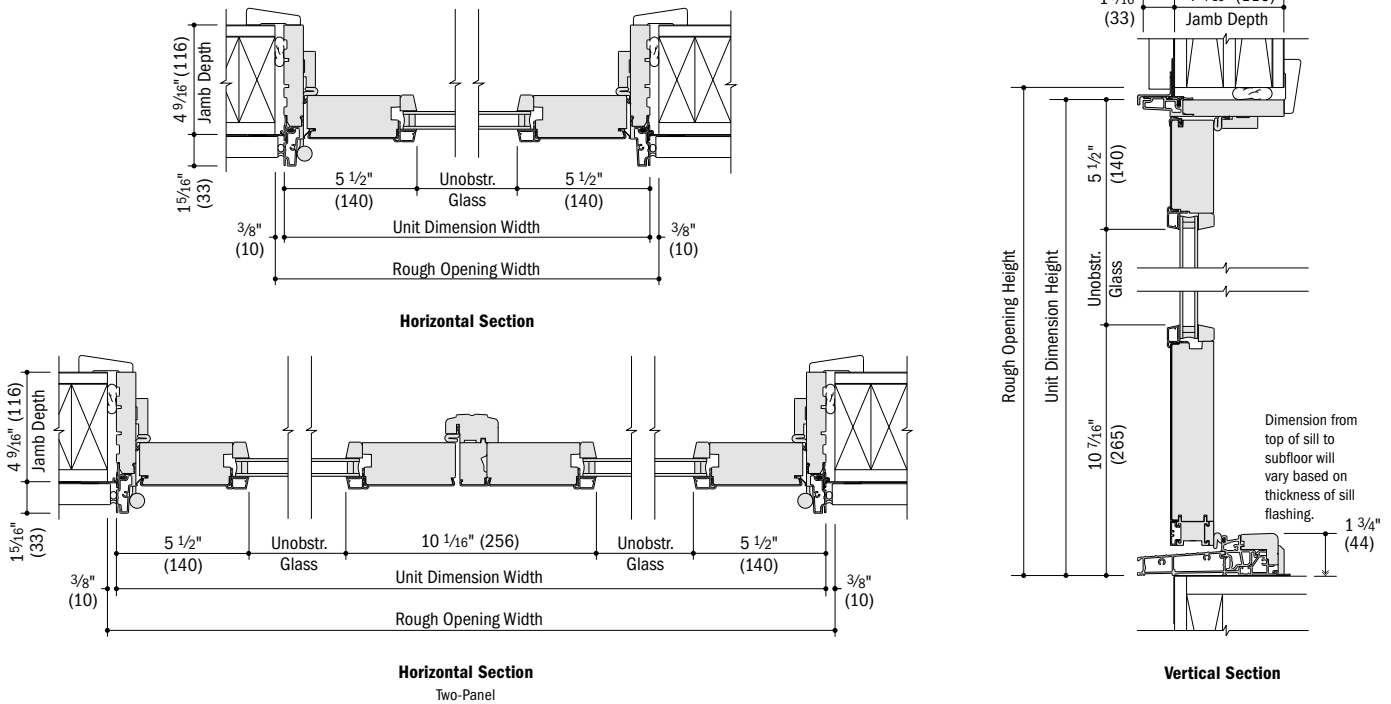

- 4 9/16" (116) jamb depth measurement is from back side of installation flange.
- Light-colored areas are parts included with door. Dark-colored areas are additional Andersen® parts required to complete door assembly as shown.
- **Rough openings may need to be increased to allow for use of building wraps, flashing, sill panning, brackets, fasteners or other items. See installation information on pages 210-211.**
- Details are for illustration only and are not intended to represent product installation methods or materials. Refer to product installation guides at [andersenwindows.com](http://andersenwindows.com).
- Dimensions in parentheses are in millimeters.

# ART GLASS

Art Glass



# ART GLASS

## FEATURES

### Frame

For most units, Andersen® art glass panel kits include pine and laminated maple trim to give each installation a finished appearance. Panels are edged with steel-reinforced zinc caming for stability. Caming finish options are available in antique (bronze), bright goldtone or silvertone.

### Package Includes

Andersen art glass panel, installation brackets, wood trim pieces (where applicable), brass screws and complete installation and cleaning instructions.

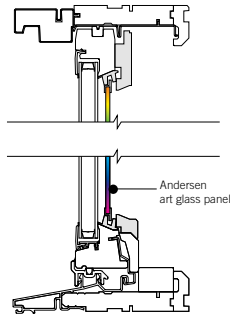

### Installation

Panels are secured with polypropylene, snap-lock installation brackets.

### Availability

Andersen art glass panels are sized to fit Andersen casement, awning, half circle, elliptical, circle, oval, arch, Flexiframe® double-hung transom and picture windows, Frenchwood® hinged patio doors, sidelights and transoms.

### Glass

Designs are offered in several standard color palettes, or choose from the many optional colors for glass and accent “jewels” to create your own unique color combinations.

### Pattern Details

Each design can be ordered in many shapes and sizes, including detailed art glass patterns for specific unit sizes.

### Color Options

Andersen gives you a choice of antique, silvertone or bright goldtone caming, the ornamental material used to hold sections of decorative glass in place.

For more information, see your Andersen supplier or visit [andersenwindows.com/artglass](http://andersenwindows.com/artglass).

## ART GLASS PATTERNS

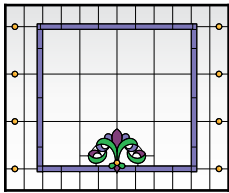

### Victoria

Violet, deep rose, deep green and amber jewels

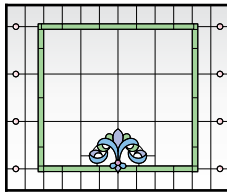

### Victoria

Light green, lilac, light blue, pink jewels and lilac jewels

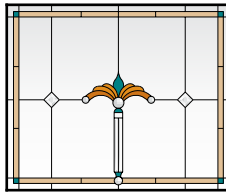

### Regency

Sand, deep teal, topaz, copper and smoke jewels

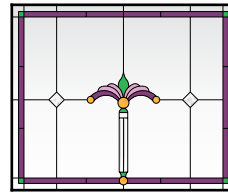

### Regency

Deep rose, deep green, rose and opal amber jewels

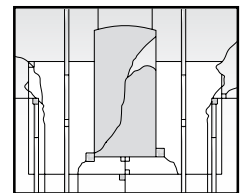

### Harmonics

Opal, sage and clear bevels (right orientation)

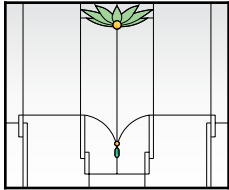

### Lotus

Light green, amber jewels and green jewels

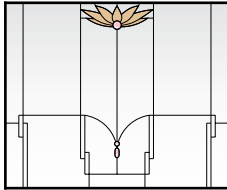

### Lotus

Sand and pink jewels

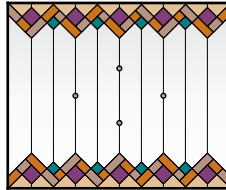

### Taos

Dusty coral, copper, sand, deep rose, deep teal and lilac jewels

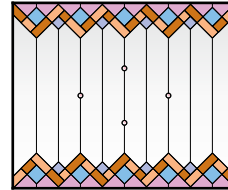

### Taos

Peach, copper, rose, lilac, light blue and pink jewels

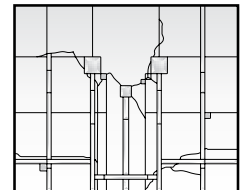

### Affinity

No color, clear bevels (right orientation)

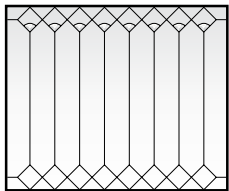

### Diamond Lights

Clear fan-shaped bevels

### CLASSIC SERIES

The Classic Series includes five different styles that represent major architectural design themes from the late 1800s through the 1930s, as well as a Southwestern-inspired design. Classic Series glass patterns are also available with semi-privacy glass or clear antique glass in place of colored glass.

### ARTISAN SERIES

Two designs influenced by 20th Century American and European architectural schools feature striking visual patterns that evoke an extraordinary blend of art and nature. Artisan Series glass patterns are available in left or right orientations, as viewed from the exterior.

## CUSTOM ART GLASS COLOR OPTIONS\*



Copper



Deep Green



Deep Rose



Deep Teal



Dusty Coral



Light Blue



Light Green



Amber



Lilac



Pink



Lilac



Peach



Rose



Sage



Sand



Topaz



Violet



Green



Opal Amber



Smoke

\* Clear, clear antique and semi-privacy glass are also available as custom art glass color options.

Andersen art glass panel patterns vary based on window size and shape. Contact your Andersen supplier for complete pattern information.

Colors in the Classic Series and Artisan Series may vary from photos and actual glass samples due to the unique character of the mouthblown glass.

Art glass changes appearance greatly based on lighting in its environment, making it beautiful to look at yet difficult to represent accurately in print. Printing limitations prevent exact color replication.

# WINDOW & DOOR EXTERIOR TRIM

Exterior Trim



## SECTION REFERENCE

3 ½" & 4 ½" Flat Casing Details..	178
Brick Mould Detail .....	179
Sill Nose Detail.....	179
Decorative Drip Cap Detail .....	180
2" & 3 ⅝" Cornice Details.....	180
Mull Cover Detail.....	180

# EXTERIOR TRIM

## FEATURES



White trim with Terratone window



- A** For exceptional long-lasting\* performance, exterior trim is made from Fibrex® material or high-density urethane with low-maintenance exterior finishes.
- B** Sill nose profile, made from Fibrex material, is placed at the sill for a traditional look.
- C** Rigid vinyl exterior trim attachment strips (field-applied) allow the trim to be securely fastened to the home.
- D** Trim surrounds are assembled with corner keys and stainless steel fasteners for stability and strength.



Our Fibrex material is an environmentally smart composite that contains 40% pre-consumer reclaimed wood fiber by weight.

### Visualizer & Video

An online trim visualizer, installation guides and videos are available at [andersenwindows.com/exteriortrim](http://andersenwindows.com/exteriortrim).

## Exterior Trim System

### Easier Installation

- Installs independently of water management system
- No nail holes to fill
- No visible fasteners
- No painting

### Profiles

Exterior trim is available in four profiles made from our Fibrex material. Profiles include 3 1/2" (89) flat casing, 4 1/2" (114) flat casing, 2" (51) brick mould and sill nose for the bottom trim piece.

Thick trim profiles overlap the window frame (as shown to the left) to create clean lines without visible sealant joints.

### Drip Cap

Full-length, color-matched aluminum drip cap is included with kits and surrounds.

### End Caps

Provide a clean appearance when joining two trim members.

### Corner Keys

Provide tight alignment of corner joints.

### Fasteners

Screws are made of high-quality stainless steel and provide corner joints with a secure, tight fit.

### Head Trim Options

Three styles are available. All can be used above our flat casing and include an integrated installation flange. The decorative drip cap is made from our Fibrex material. Both the 2" (51) cornice and 3 5/8" (92) cornice are made from highly durable urethane material. See head trim options on next page.

### Specialty Trim



Made of highly durable factory-finished urethane material for selected shapes. Contact your Andersen supplier for availability.

## PROFILES



**2" (51) BRICK MOULD**  
Dove gray trim with Terratone window



**3 1/2" (89) Flat Casing**  
Dark bronze trim with white window



**4 1/2" (114) Flat Casing**  
Canvas trim with forest green window

## COLORS

Trim can match or complement your window and door colors to create a wide range of combinations.



White Canvas Sandtone Terratone Forest Green Dark Bronze Dove Gray Prairie Grass Red Rock Cocoa Bean Black

\* Visit [andersenwindows.com/warranty](http://andersenwindows.com/warranty) for details.

Dimensions in parentheses are in millimeters.

Printing limitations prevent exact duplication of colors. See your Andersen supplier for actual color samples.

## Installation Options

### Preassembled Trim Surrounds

Factory-assembled surrounds install quickly and eliminate measuring, cutting, mitering and filling nail holes.

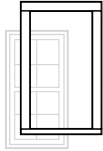

### Precut Kits

Knock down kits include precut and predrilled trim with all the necessary components for on-site assembly for windows.

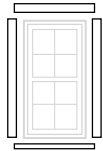

### Individual Trim Components

13' (3962) factory-finished trim lineals, end caps, corner keys, fasteners, metal drip caps and field attachment strips allow for field fabrication and assembly.



## ACCESSORIES Sold Separately

### Fibrex® Trim Board



Andersen offers a 3 1/2" (89) wide by 3/4" (19) thick cellular Fibrex trim board in 10' (3048) lengths. Available in the same 11 colors as the exterior trim system, this solid trim board can be ripped to size and can be fastened using nails or screws.

### Coil Stock



Factory-finished in any of our 11 exterior trim colors, our aluminum coil stock allows you to form your own profiles in the field. Made from .018" thick aluminum, coil stock is available in 24" (610) x 50' (15240) rolls. Color-matched stainless steel trim nails are also available and can be ordered in 1 lb/.454 kg boxes.

## HEAD TRIM OPTIONS



**DECORATIVE DRIP CAP**  
Shown with 3 1/2" (89) flat casing in red rock trim with Sandtone window



**2" (51) CORNICE**  
Shown with 3 1/2" (89) flat casing in red rock trim with Sandtone window



**3 5/8" (92) CORNICE**  
Shown with 3 1/2" (89) flat casing in red rock trim with Sandtone window

Exterior Trim

## TRIM COMBINATIONS

Not all trim options and/or combinations are shown. Contact your Andersen supplier for more information.

### 3 1/2" (89) or 4 1/2" (114) Flat Casing

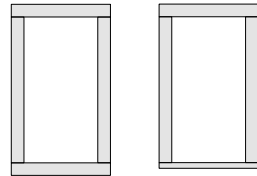

Flat casing can be used on all four sides flush at the head and sill. Combine 3 1/2" (89) and 4 1/2" (114) flat casing or use with a flush sill nose.

### Brick Mould

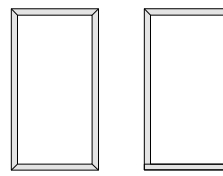

Brick mould can be used on all four sides or with a flush sill nose.

### Sill Nose

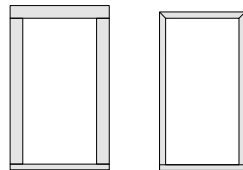

Sill nose can be used with flat casing or brick mould.

### Decorative Drip Cap and Cornices

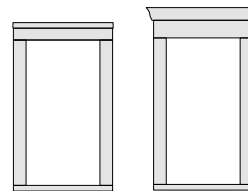

Decorative drip cap or cornices can be used above flat casing at the head.

# EXTERIOR TRIM

## Window and Patio Door Attachment

### Field-Applied Attachment Strip

Field-applied attachment strip fastens to framing through window or patio door installation flange and flashing tape with screws. Exterior trim connects securely to the field-applied attachment strip. Follow window and patio door installation guides for flashing instructions.

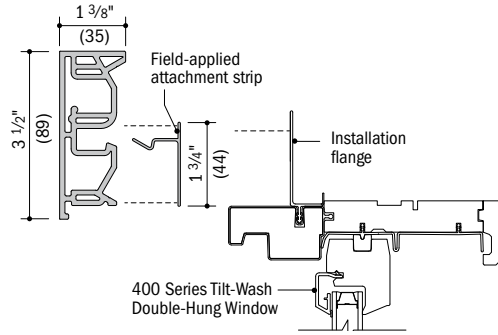

### 3 1/2" (89) and 4 1/2" (114) Flat Casing

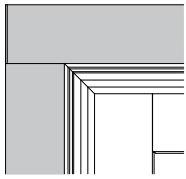

3 1/2" (89) flat casing with flush corner

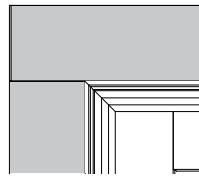
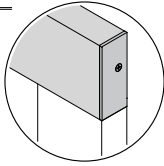

4 1/2" (114) flat casing with flush corner

Formula for dimension of window/door plus exterior trim:

**Add 4 1/4" (108) per side for 4 1/2" (114) flat casing**

**Add 3 1/4" (83) per side for 3 1/2" (89) flat casing**

### Trim Details

Scale 3" (76) = 1'-0" (305) – 1:4

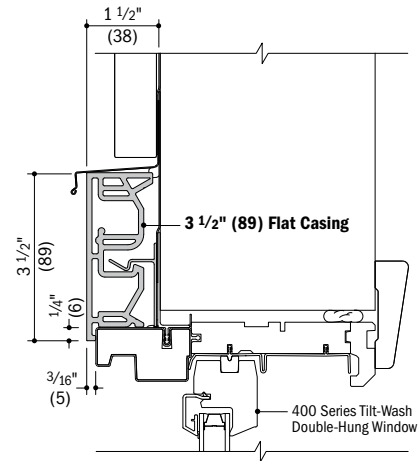

#### Vertical Section

400 Series Tilt-Wash Double-Hung Window with 3 1/2" (89) Flat Casing

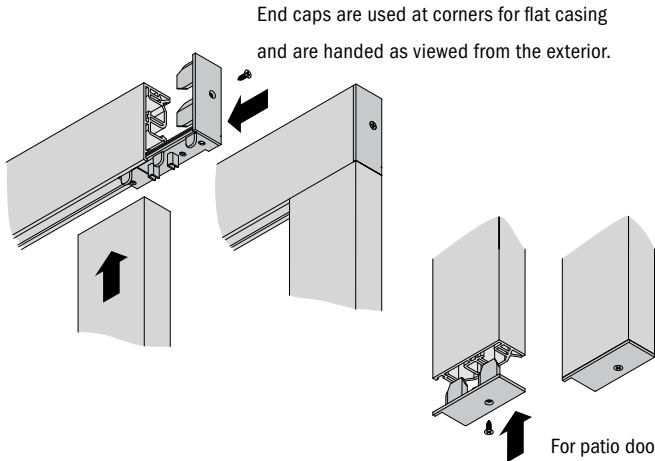

End caps are used at corners for flat casing and are handed as viewed from the exterior.

For patio doors, end caps are used at the sill.

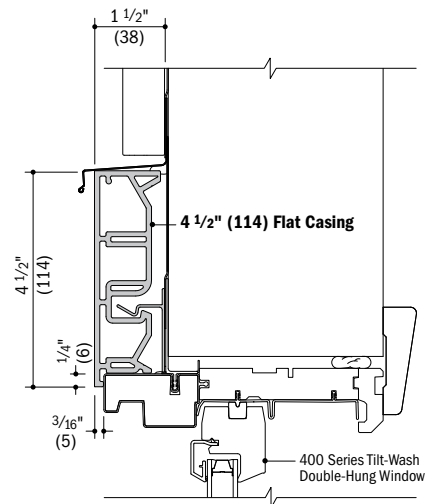

#### Vertical Section

400 Series Tilt-Wash Double-Hung Window with 4 1/2" (114) Flat Casing

\* Dimensions in parentheses are in millimeters.

\* Typical trim combinations shown. Additional combinations may also be used. Some restrictions apply. For more information contact your Andersen supplier.

\* Details are for illustration only and are not intended to represent product installation methods or materials. Refer to product installation guides at [andersenwindows.com](http://andersenwindows.com).

**Brick Mould**

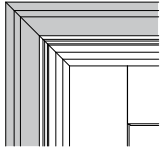

Brick mould with mitered corners

Formula for dimension of window/door plus exterior trim:

**Add 1 3/4" (44) per side for brick mould**

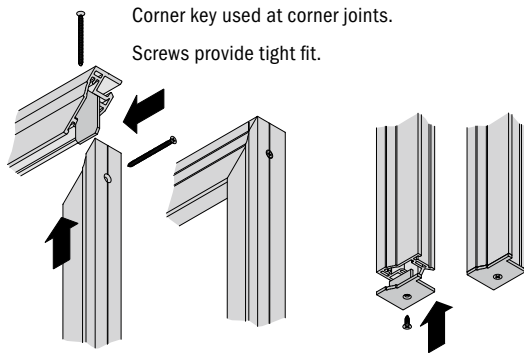

For patio doors, end caps are used at the sill.

**Trim Detail**

Scale 3" (76) = 1'-0" (305) – 1:4

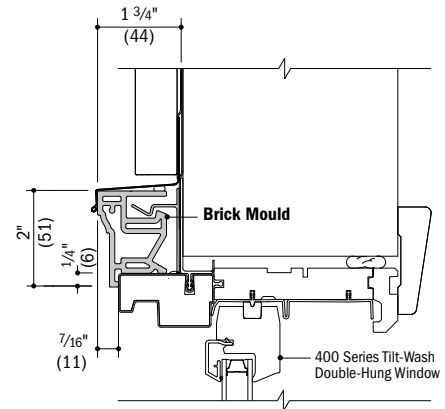

**Vertical Section**

400 Series Tilt-Wash Double-Hung Window with Brick Mould

Exterior Trim

**Sill Nose**

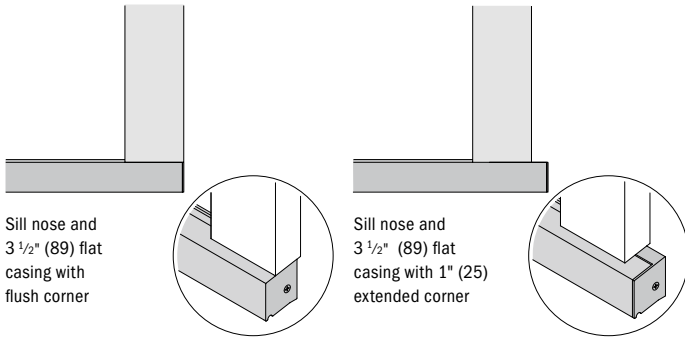

Sill nose and 3 1/2" (89) flat casing with flush corner

Sill nose and 3 1/2" (89) flat casing with 1" (25) extended corner

Formula for dimension of window plus exterior trim:

**Add 1 15/16" (49) for sill nose**

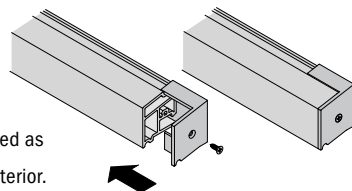

**Trim Detail**

Scale 3" (76) = 1'-0" (305) – 1:4

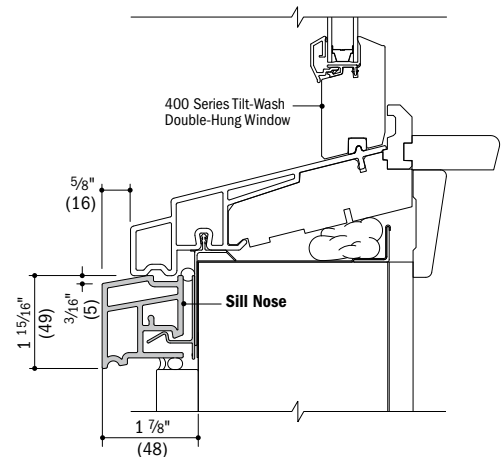

**Vertical Section**

400 Series Tilt-Wash Double-Hung Window with Sill Nose

\*Dimensions in parentheses are in millimeters.  
\*Typical trim combinations shown. Additional combinations may also be used. Some restrictions apply. For more information contact your Andersen supplier.  
\*Details are for illustration only and are not intended to represent product installation methods or materials. Refer to product installation guides at andersenwindows.com.

# EXTERIOR TRIM

## Decorative Drip Cap

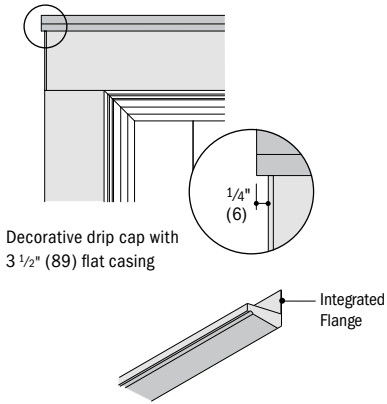

Decorative drip cap with 3 1/2" (89) flat casing

## Cornices

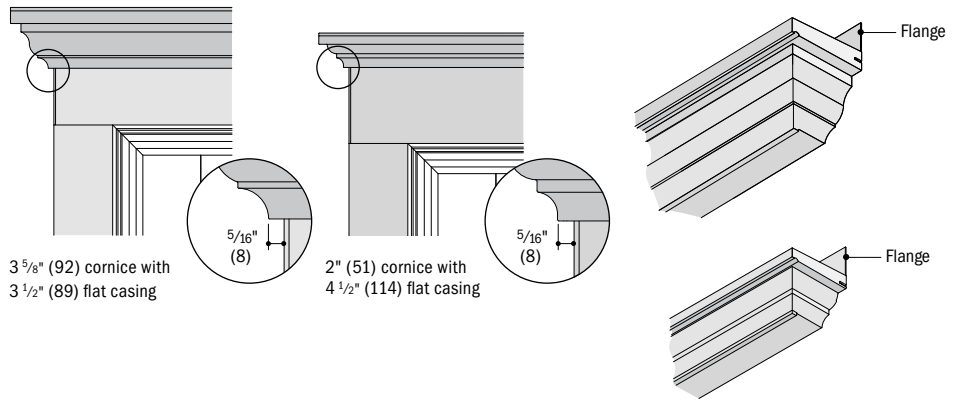

3 5/8" (92) cornice with 3 1/2" (89) flat casing

2" (51) cornice with 4 1/2" (114) flat casing

## Details

Scale 3" (76) = 1'-0" (305) – 1:4

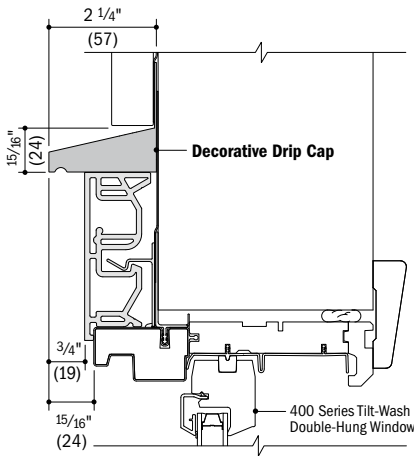

**Vertical Section**

400 Series Tilt-Wash Double-Hung Window with 3 1/2" (89) Flat Casing and Decorative Drip Cap

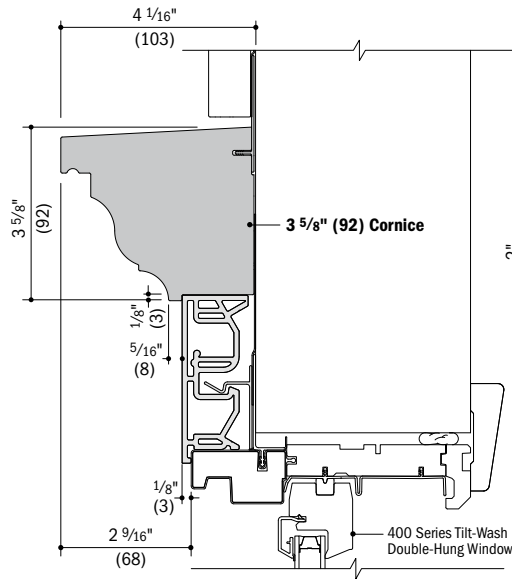

**Vertical Section**

400 Series Tilt-Wash Double-Hung Window with 3 1/2" (89) Flat Casing and 3 5/8" (92) Cornice

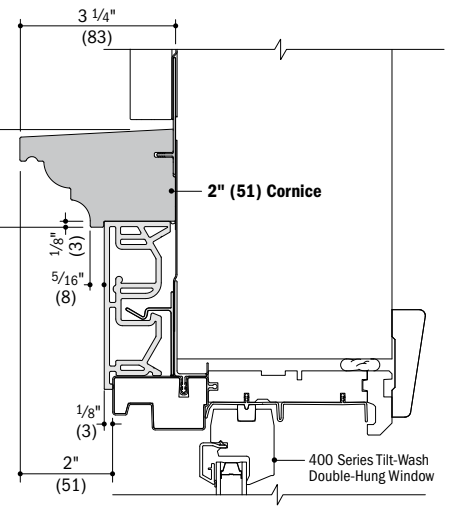

**Vertical Section**

400 Series Tilt-Wash Double-Hung Window with 3 1/2" (89) Flat Casing and 2" (51) Cornice

## Mull Cover

3 3/4" (95) mull cover is available for installations where windows or patio doors have been installed into separate rough openings to obtain a joined appearance.

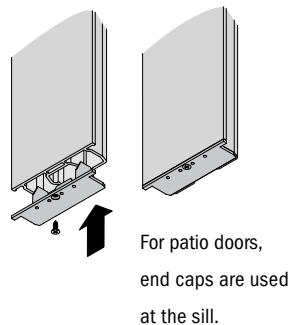

## Separate Rough Opening Detail

Scale 3" (76) = 1'-0" (305) – 1:4

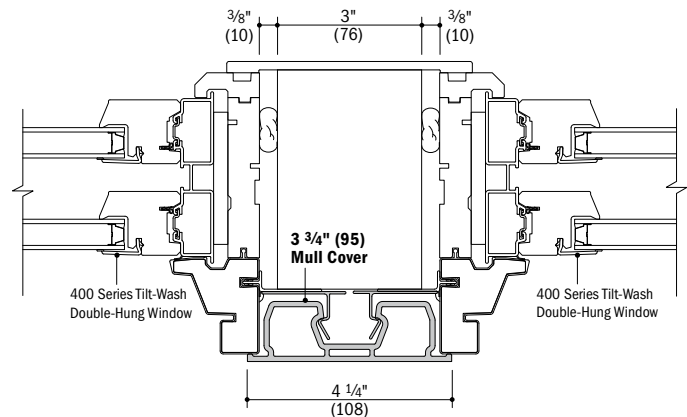

**Horizontal Section**

400 Series Tilt-Wash Double-Hung Windows and 3 3/4" (95) Mull Cover

\* Dimensions in parentheses are in millimeters.

\* Typical trim combinations shown. Additional combinations may also be used. Some restrictions apply. For more information contact your Andersen supplier.

\* Details are for illustration only and are not intended to represent product installation methods or materials. Refer to product installation guides at andersenwindows.com.

\* Consult with an architect or structural engineer regarding minimum requirements for structural support members between adjacent rough openings.

# Andersen<sup>®</sup> windows and patio doors make it easy to create a wide variety of combination designs.

## Combination Types

### Ribbons

Ribbons are horizontal window combinations (vertical joins) where opposite ends (head and sill) of individual windows are fastened to the building structure.

### Stacks

Stacks are vertical window combinations (horizontal joins) where opposite sides (both side jambs) of individual windows are fastened to the building structure.

Two basic configurations are used in combination designs: one-way configurations or two-way configurations.

### One-Way

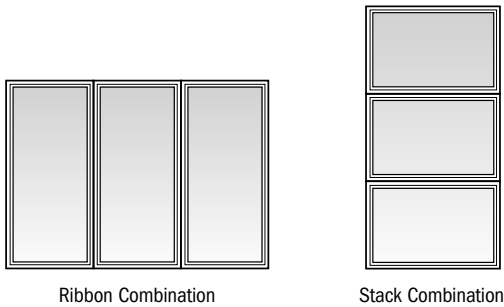

### Two-Way

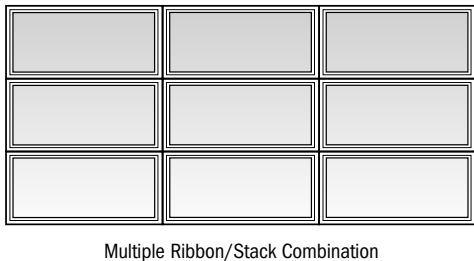

Two-way combinations exist when multiple vertical stacks and horizontal ribbons are joined together. Unlike one-way combinations, the adjacent sides (head and sill, or both side jambs) of individual units are not necessarily fastened directly to the building structure. Two-way combinations are joined with both vertical and horizontal joining material and may require reinforced joining materials and brackets depending on the local building code requirement for design wind load (measured in pounds per square foot, PSF).

## Determining Design Wind Load Performance

Proper combination design in conformance with local wind load requirements is vital to the success of your project. To make sure a combination is safe and that it complies with local building codes, the combination design wind load performance capacity must be determined.

Correctly determining this performance capacity involves the following three steps:

### STEP 1

#### Determine Building Code Requirement

Make sure that you have the proper local codes and have identified specified compliance values. This calculated value (PSF) will be used to determine if the combination will be acceptable (STEP 3).



### STEP 2

#### Determine Product Performance

Compare product Design Pressure Rating data to the local building code (PSF) requirement. This will show whether the individual units in a combination design are acceptable.



### STEP 3

#### Determine Combination Performance

This step helps determine whether a given product, size, configuration and joining material type will meet the local building code design wind load requirement. To determine what joining material type to use (LVL, steel, aluminum or wood), compare the local building code design wind load requirement to the Design Wind Load Table value for a particular joining material on the following pages.

# COMBINATION DESIGNS

## Andersen® Joining Materials and Installation Accessories

For a successful installation, designed to provide the required design pressure, it is important that Andersen joining materials and installation accessories be specified by a project architect or contractor. Andersen offers several types of joining materials. Each creates a joining system that maintains the look of Andersen products. Choose the type appropriate for your combination design. Components used with each joining system will vary depending on products being joined. Check with your Andersen supplier for more information.

The addition of joining materials will affect the overall rough opening dimension, see page 210. **Instruction guides are available at [andersenwindows.com](http://andersenwindows.com). Read and follow instruction guides in their entirety.**

**Andersen Exterior Trim Strips** – A variety of trim strips for finishing the space between joined products are available in colors to match Andersen windows and doors.

**Andersen Interior Wood Casing** – Available in several wood types, pre-finished options, sizes and style options, including laminated arch casings, decorative plinths and key blocks.

Materials vary depending on type of units being joined and wind load requirements.

Non-reinforced joining materials are used to create alignment and positive joining between windows. Joining materials are not connected to the rough opening structure. Non-reinforced joins can also be achieved using accessory items such as v-notch gusset plates. Please contact your Andersen supplier for specific performance and product recommendations.

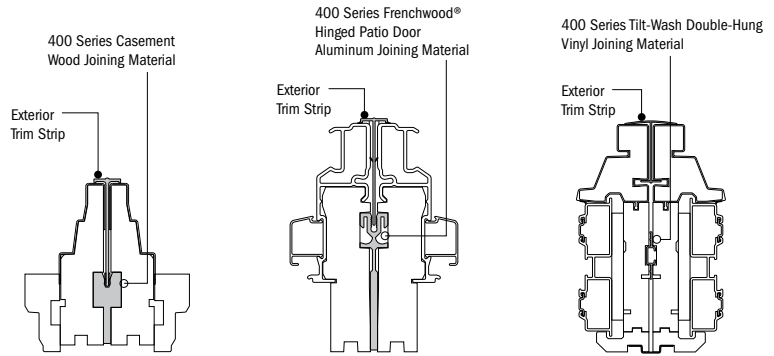

Reinforced joining materials are used to create product alignment, positive joining and load transfer between the Andersen windows and doors and the rough opening. They provide added strength capable of withstanding a variety of wind load pressures. The structural performance of any combination is only as high as the lowest structural performance rating of any individual window or joining material in the combination.

### Laminated Veneer Lumber (LVL) Joining Material

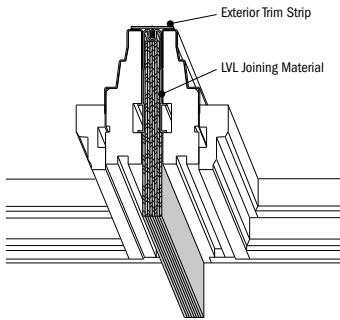

LVL joining material is available for both windows and patio doors. Both 4 9/16" (116) x 3/4" (19) LVL and 6 9/16" (167) x 3/4" (19) LVL are available and include an aluminum exterior trim strip retainer. LVL materials are available in a variety of lengths up to 10' (3048). Use with casement, awning, double-hung and select specialty windows and patio doors.

### Steel Joining Material

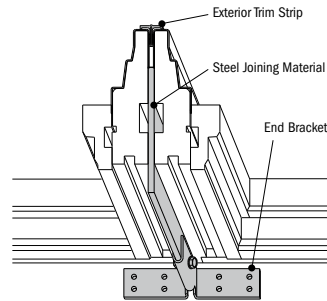

Available in 8'-0 1/4" (2445), 9'-6" (2896) and 12'-6" (3810) lengths. Treated for corrosion resistance, the material has a 4" (102) depth that provides strength and rigidity. Adjacent windows attach to the steel joining with screws provided in the kit. Use with casement, awning, double-hung and select specialty windows.

### Aluminum Joining Material

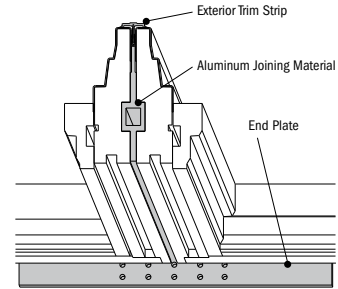

Available in 6'-0 3/32" (1831) and 7'-8" (2337) lengths. High-quality aluminum provides increased stiffness and is anodized for corrosion resistance. Aluminum joining stays within the basic jamb of the window so interior casing can be used without extension jambs. Adjacent windows attach to the aluminum joining with screws provided in the kit. Use with casement, awning and select specialty windows.

\* Dimensions in parentheses are in millimeters.

\* Structural performance of any combination is only as high as the lowest structural performance of any individual unit or joining material in the combination.

Casement & Awning Windows

**One-Way Wood Joining**

400 Series Casement, Awning, Complementary Specialty Joined with Flexiframe® Windows

Average Adjacent Window Dimension	(A + B) + 2 = <b>12'-6"</b> (3810)	70	58	40	29	22					
	(A + B) + 2 = <b>12'-0"</b> (3658)	70	58	40	29	22					
	(A + B) + 2 = <b>11'-6"</b> (3505)	70	58	40	29	22					
	(A + B) + 2 = <b>11'-0"</b> (3353)	70	58	40	29	22					
	(A + B) + 2 = <b>10'-6"</b> (3200)	70	58	40	29	22					
	(A + B) + 2 = <b>10'-0"</b> (3048)	70	58	40	29	22					
	(A + B) + 2 = <b>9'-6"</b> (2896)	70	58	40	29	22					
	(A + B) + 2 = <b>9'-0"</b> (2743)	70	58	40	29	22					
	(A + B) + 2 = <b>8'-6"</b> (2591)	70	58	40	29	22					
	(A + B) + 2 = <b>8'-0"</b> (2438)	70	58	40	29	22					
	(A + B) + 2 = <b>7'-6"</b> (2286)	70	58	40	29	22					
	(A + B) + 2 = <b>7'-0"</b> (2134)	70	58	40	29	22					
	(A + B) + 2 = <b>6'-6"</b> (1981)	70	58	40	29	22					
	(A + B) + 2 = <b>6'-0"</b> (1829)	70	58	40	29	22					
	(A + B) + 2 = <b>5'-6"</b> (1676)	70	58	40	29	22					
	(A + B) + 2 = <b>5'-0"</b> (1524)	70	58	40	29	22					
	(A + B) + 2 = <b>4'-6"</b> (1372)	70	58	40	30	23					
	(A + B) + 2 = <b>4'-0"</b> (1219)	70	58	41	31	24	20				
	(A + B) + 2 = <b>3'-6"</b> (1067)	70	59	43	33	27	22				
	(A + B) + 2 = <b>3'-0"</b> (914)	70	63	47	37	30	25	21			
(A + B) + 2 = <b>2'-6"</b> (762)	70	70	54	43	35	29	24	21			
(A + B) + 2 = <b>2'-0"</b> (610)	70	70	65	52	42	35	30	26	22		
(A + B) + 2 = <b>1'-6"</b> (457)	70	70	70	68	56	46	39	34	29	26	
<b>C = (length of join)</b>	<b>3'-6"</b> (1067)	<b>4'-0"</b> (1219)	<b>4'-6"</b> (1372)	<b>5'-0"</b> (1524)	<b>5'-6"</b> (1676)	<b>6'-0"</b> (1829)	<b>6'-6"</b> (1981)	<b>7'-0"</b> (2134)	<b>7'-6"</b> (2286)	<b>8'-0"</b> (2438)	

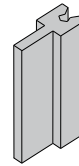
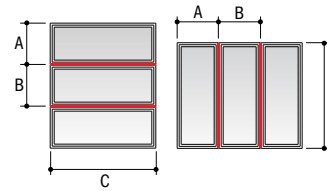

Wood Joining Material

Note: Stacking of windows is allowed to a maximum height of 12'-6" (3810). Contact your Andersen supplier for information about taller combination heights.

Combination Design, Product Performance & Installation

**One-Way Wood Joining**

400 Series Casement, Awning and Complementary Specialty Windows

Average Adjacent Window Dimension	(A + B) + 2 = <b>12'-6"</b> (3810)	70	70	58	42	32	24	20			
	(A + B) + 2 = <b>12'-0"</b> (3658)	70	70	58	42	32	24	20			
	(A + B) + 2 = <b>11'-6"</b> (3505)	70	70	58	42	32	24	20			
	(A + B) + 2 = <b>11'-0"</b> (3353)	70	70	58	42	32	24	20			
	(A + B) + 2 = <b>10'-6"</b> (3200)	70	70	58	42	32	24	20			
	(A + B) + 2 = <b>10'-0"</b> (3048)	70	70	58	42	32	24	20			
	(A + B) + 2 = <b>9'-6"</b> (2896)	70	70	58	42	32	24	20			
	(A + B) + 2 = <b>9'-0"</b> (2743)	70	70	58	42	32	24	20			
	(A + B) + 2 = <b>8'-6"</b> (2591)	70	70	58	42	32	24	20			
	(A + B) + 2 = <b>8'-0"</b> (2438)	70	70	58	42	32	24	20			
	(A + B) + 2 = <b>7'-6"</b> (2286)	70	70	58	42	32	24	20			
	(A + B) + 2 = <b>7'-0"</b> (2134)	70	70	58	42	32	24	20			
	(A + B) + 2 = <b>6'-6"</b> (1981)	70	70	58	42	32	24	20			
	(A + B) + 2 = <b>6'-0"</b> (1829)	70	70	58	42	32	24	20			
	(A + B) + 2 = <b>5'-6"</b> (1676)	70	70	58	42	32	25	20			
	(A + B) + 2 = <b>5'-0"</b> (1524)	70	70	58	42	32	25	21			
	(A + B) + 2 = <b>4'-6"</b> (1372)	70	70	58	43	33	27	22			
	(A + B) + 2 = <b>4'-0"</b> (1219)	70	70	59	45	35	29	24	20		
	(A + B) + 2 = <b>3'-6"</b> (1067)	70	70	63	48	38	31	26	22		
	(A + B) + 2 = <b>3'-0"</b> (914)	70	70	68	54	43	36	30	25	22	
(A + B) + 2 = <b>2'-6"</b> (762)	70	70	70	62	50	42	35	30	26	22	
(A + B) + 2 = <b>2'-0"</b> (610)	70	70	70	70	61	51	43	37	32	27	
(A + B) + 2 = <b>1'-6"</b> (457)	70	70	70	70	70	67	57	49	42	35	
<b>C = (length of join)</b>	<b>3'-6"</b> (1067)	<b>4'-0"</b> (1219)	<b>4'-6"</b> (1372)	<b>5'-0"</b> (1524)	<b>5'-6"</b> (1676)	<b>6'-0"</b> (1829)	<b>6'-6"</b> (1981)	<b>7'-0"</b> (2134)	<b>7'-6"</b> (2286)	<b>8'-0"</b> (2438)	

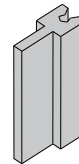
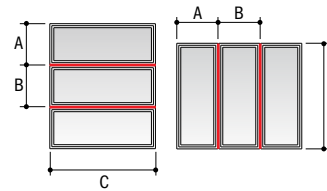

Wood Joining Material

Note: Stacking of windows is allowed to a maximum height of 12'-6" (3810). Contact your Andersen supplier for information about taller combination heights.

\* Numerical values in charts represent structural pressure only.  
 \* Dimensions in parentheses are in millimeters.  
 \* Structural performance of any combination is only as high as the lowest structural performance of any individual unit or joining material in the combination.  
 \* Andersen® products must be installed and anchored properly according to joining and installation guides to meet rated structural performance. Refer to product joining and installation guides at andersenwindows.com.  
 \* Additional wind load tables are available at andersenwindows.com.

# COMBINATION DESIGNS

## Casement & Awning Windows

### Two-Way Wood Joining

400 Series Casement, Awning, Complementary Specialty and Flexiframe® Windows

Average Adjacent Window Dimension	(A + B) ÷ 2 = <b>8'-6"</b> (2591)	20									
	(A + B) ÷ 2 = <b>8'-0"</b> (2438)	21									
	(A + B) ÷ 2 = <b>7'-6"</b> (2286)	23									
	(A + B) ÷ 2 = <b>7'-0"</b> (2134)	24									
	(A + B) ÷ 2 = <b>6'-6"</b> (1981)	26	20								
	(A + B) ÷ 2 = <b>6'-0"</b> (1829)	28	22								
	(A + B) ÷ 2 = <b>5'-6"</b> (1676)	31	24								
	(A + B) ÷ 2 = <b>5'-0"</b> (1524)	34	26	20							
	(A + B) ÷ 2 = <b>4'-6"</b> (1372)	38	29	23							
	(A + B) ÷ 2 = <b>4'-0"</b> (1219)	43	33	26	21						
	(A + B) ÷ 2 = <b>3'-6"</b> (1067)	49	37	29	24						
	(A + B) ÷ 2 = <b>3'-0"</b> (914)	57	44	34	28	23					
	(A + B) ÷ 2 = <b>2'-6"</b> (762)	69	52	41	33	27	23				
	(A + B) ÷ 2 = <b>2'-0"</b> (610)	70	66	52	42	34	29	23			
(A + B) ÷ 2 = <b>1'-6"</b> (457)	70	70	69	56	46	39	31	24	20		
<b>C = (length of join)</b>	<b>3'-6"</b> (1067)	<b>4'-0"</b> (1219)	<b>4'-6"</b> (1372)	<b>5'-0"</b> (1524)	<b>5'-6"</b> (1676)	<b>6'-0"</b> (1829)	<b>6'-6"</b> (1981)	<b>7'-0"</b> (2134)	<b>7'-6"</b> (2286)		

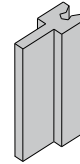
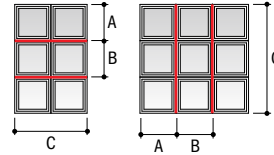

Wood Joining Material

### One-Way or Two-Way Aluminum Joining

400 Series Casement, Awning, Complementary Specialty and Flexiframe Windows

Average Adjacent Window Dimension	(A + B) ÷ 2 = <b>9'-0"</b> (2743)	70	56	41	31	23				
	(A + B) ÷ 2 = <b>8'-6"</b> (2591)	70	60	43	32	25				
	(A + B) ÷ 2 = <b>8'-0"</b> (2438)	70	63	46	34	26	21			
	(A + B) ÷ 2 = <b>7'-6"</b> (2286)	70	67	49	36	28	22			
	(A + B) ÷ 2 = <b>7'-0"</b> (2134)	70	70	52	39	30	23			
	(A + B) ÷ 2 = <b>6'-6"</b> (1981)	70	70	56	42	32	25	20		
	(A + B) ÷ 2 = <b>6'-0"</b> (1829)	70	70	60	45	35	27	21		
	(A + B) ÷ 2 = <b>5'-6"</b> (1676)	70	70	66	49	38	29	23		
	(A + B) ÷ 2 = <b>5'-0"</b> (1524)	70	70	70	54	41	32	26	21	
	(A + B) ÷ 2 = <b>4'-6"</b> (1372)	70	70	70	59	45	35	28	23	
	(A + B) ÷ 2 = <b>4'-0"</b> (1219)	70	70	70	66	50	39	31	25	
	(A + B) ÷ 2 = <b>3'-6"</b> (1067)	70	70	70	70	57	44	35	28	
	(A + B) ÷ 2 = <b>3'-0"</b> (914)	70	70	70	70	65	51	40	33	
	(A + B) ÷ 2 = <b>2'-6"</b> (762)	70	70	70	70	70	60	48	39	
(A + B) ÷ 2 = <b>2'-0"</b> (610)	70	70	70	70	70	70	59	48		
(A + B) ÷ 2 = <b>1'-6"</b> (457)	70	70	70	70	70	70	70	63		
<b>C = (length of join)</b>	<b>4'-0"</b> (1219)	<b>4'-6"</b> (1372)	<b>5'-0"</b> (1524)	<b>5'-6"</b> (1676)	<b>6'-0"</b> (1829)	<b>6'-6"</b> (1981)	<b>7'-0"</b> (2134)	<b>7'-6"</b> (2286)		

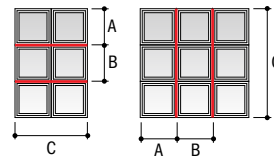

Aluminum Joining Material

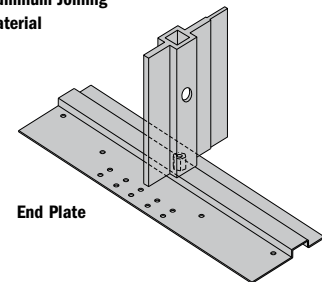

End Plate



For a join with a continuous jamb on one side, multiply PSF by 1.2.



For a join with a continuous jamb on both sides, multiply PSF by 1.4.

\* Numerical values in charts represent structural pressure only.

\* Dimensions in parentheses are in millimeters.

\* Structural performance of any combination is only as high as the lowest structural performance of any individual unit or joining material in the combination.

\* Andersen® products must be installed and anchored properly according to joining and installation guides to meet rated structural performance. Refer to product joining and installation guides at andersenwindows.com.

\* Additional wind load tables are available at andersenwindows.com.



# COMBINATION DESIGNS

## Casement & Awning Windows

### One-Way LVL Joining

400 Series Casement, Awning, Complementary Specialty and Flexiframe® Windows

<b>4 9/16" (116) LVL</b>	Average Adjacent Window Dim.	(A + B) ÷ 2 = <b>6'-0"</b> (1829)	70	70	56	45				
		(A + B) ÷ 2 = <b>5'-6"</b> (1676)	70	70	61	50				
		(A + B) ÷ 2 = <b>5'-0"</b> (1524)	70	70	68	55	45	36		
		(A + B) ÷ 2 = <b>4'-6"</b> (1372)	70	70	70	61	51	43	37	
		(A + B) ÷ 2 = <b>4'-0"</b> (1219)	70	70	70	70	58	49	42	35
		(A + B) ÷ 2 = <b>3'-6"</b> (1067)	70	70	70	70	68	56	49	39
		(A + B) ÷ 2 = <b>3'-0"</b> (914)	70	70	70	70	70	63	53	45
		(A + B) ÷ 2 = <b>2'-6"</b> (762)	70	70	70	70	70	70	62	53
		(A + B) ÷ 2 = <b>2'-0"</b> (610)	70	70	70	70	70	70	62	53
		(A + B) ÷ 2 = <b>1'-6"</b> (457)	70	70	70	70	70	70	62	53
		<b>C = (length of join)</b>	<b>3'-6"</b> (1067)	<b>4'-0"</b> (1219)	<b>4'-6"</b> (1372)	<b>5'-0"</b> (1524)	<b>5'-6"</b> (1676)	<b>6'-0"</b> (1829)	<b>6'-6"</b> (1981)	<b>7'-0"</b> (2134)

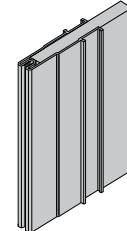
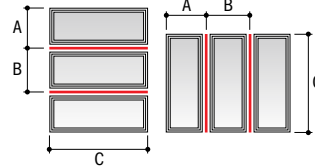

**4 9/16" (116) x 3/4" (19) LVL Joining Material**

### Two-Way LVL Joining

400 Series Casement, Awning, Complementary Specialty and Flexiframe® Windows

<b>4 9/16" (116) LVL</b>	Average Adjacent Window Dim.	(A + B) ÷ 2 = <b>6'-0"</b> (1829)	65	65	51	41				
		(A + B) ÷ 2 = <b>5'-6"</b> (1676)	70	70	56	45				
		(A + B) ÷ 2 = <b>5'-0"</b> (1524)	70	70	62	50	41	34		
		(A + B) ÷ 2 = <b>4'-6"</b> (1372)	70	70	68	55	46	38	33	
		(A + B) ÷ 2 = <b>4'-0"</b> (1219)	70	70	70	62	51	43	37	32
		(A + B) ÷ 2 = <b>3'-6"</b> (1067)	70	70	70	70	59	49	42	36
		(A + B) ÷ 2 = <b>3'-0"</b> (914)	70	70	70	70	69	58	49	42
		(A + B) ÷ 2 = <b>2'-6"</b> (762)	70	70	70	70	70	69	59	51
		(A + B) ÷ 2 = <b>2'-0"</b> (610)	70	70	70	70	61	69	59	51
		(A + B) ÷ 2 = <b>1'-6"</b> (457)	70	70	70	70	61	69	59	51
		<b>C = (length of join)</b>	<b>3'-6"</b> (1067)	<b>4'-0"</b> (1219)	<b>4'-6"</b> (1372)	<b>5'-0"</b> (1524)	<b>5'-6"</b> (1676)	<b>6'-0"</b> (1829)	<b>6'-6"</b> (1981)	<b>7'-0"</b> (2134)

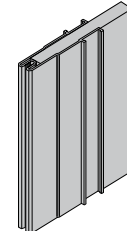
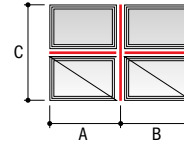

**4 9/16" (116) x 3/4" (19) LVL Joining Material**

<b>6 9/16" (167) LVL</b>	Average Adjacent Window Dimension	(A + B) ÷ 2 = <b>10'-0"</b> (3048)	70	70	63	56	48	44	37	31	24	
		(A + B) ÷ 2 = <b>9'-6"</b> (2896)	70	70	63	56	48	44	37	31	24	
		(A + B) ÷ 2 = <b>9'-0"</b> (2743)	70	70	63	56	48	44	37	31	24	
		(A + B) ÷ 2 = <b>8'-6"</b> (2591)	70	70	63	56	48	44	37	31	25	
		(A + B) ÷ 2 = <b>8'-0"</b> (2438)	70	70	63	56	48	44	37	31	25	
		(A + B) ÷ 2 = <b>7'-6"</b> (2286)	70	70	63	56	48	44	38	32	26	
		(A + B) ÷ 2 = <b>7'-0"</b> (2134)	70	70	63	56	49	45	39	33	26	
		(A + B) ÷ 2 = <b>6'-6"</b> (1981)	70	70	63	57	50	46	40	34	28	
		(A + B) ÷ 2 = <b>6'-0"</b> (1829)	70	70	64	58	51	47	41	35	29	
		(A + B) ÷ 2 = <b>5'-6"</b> (1676)	70	70	66	60	54	50	44	37	30	
		(A + B) ÷ 2 = <b>5'-0"</b> (1524)	70	70	68	63	56	52	46	39	32	
		(A + B) ÷ 2 = <b>4'-6"</b> (1372)	70	70	70	67	60	56	50	43	35	
		(A + B) ÷ 2 = <b>4'-0"</b> (1219)	70	70	70	70	64	60	53	46	38	
		(A + B) ÷ 2 = <b>3'-6"</b> (1067)	70	70	70	70	70	67	60	52	42	
		(A + B) ÷ 2 = <b>3'-0"</b> (914)	70	70	70	70	70	70	66	57	47	
		(A + B) ÷ 2 = <b>2'-6"</b> (762)	70	70	70	70	70	70	70	68	56	
		(A + B) ÷ 2 = <b>2'-0"</b> (610)	70	70	70	70	70	70	70	70	66	
		(A + B) ÷ 2 = <b>1'-6"</b> (457)	70	70	70	70	70	70	70	70	70	
		<b>C = (length of join)</b>	<b>6'-0"</b> (1829) or less	<b>6'-6"</b> (1981)	<b>7'-0"</b> (2134)	<b>7'-6"</b> (2286)	<b>8'-0"</b> (2438)	<b>8'-6"</b> (2591)	<b>9'-0"</b> (2743)	<b>9'-6"</b> (2896)	<b>10'-0"</b> (3048)	

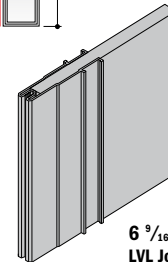
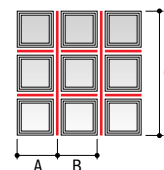

**6 9/16" (167) x 3/4" (19) LVL Joining Material**

**Note: Two-way joining must be assembled on the jobsite within the rough opening.**

- Numerical values in charts represent structural pressure only.
- Dimensions in parentheses are in millimeters.
- Structural performance of any combination is only as high as the lowest structural performance of any individual unit or joining material in the combination.
- Andersen® products must be installed and anchored properly according to joining and installation guides to meet rated structural performance. Refer to product joining and installation guides at [andersenwindows.com](http://andersenwindows.com).
- Additional wind load tables are available at [andersenwindows.com](http://andersenwindows.com).



# COMBINATION DESIGNS

## Double-Hung Full-Frame Windows

### One-Way Vinyl Joining with V-Notch Gusset Plates

400 Series Woodwright® Double-Hung, Picture and Transom Full-Frame Windows & Tilt-Wash Double-Hung, Picture and Transom Full-Frame Windows

Average Adjacent Window Dimension	(A + B) ÷ 2 = <b>12'-6"</b> (3810)	50	48	41	33	29	24	22											
	(A + B) ÷ 2 = <b>12'-0"</b> (3658)	50	48	41	33	29	24	22											
	(A + B) ÷ 2 = <b>11'-6"</b> (3505)	50	48	41	33	29	24	22											
	(A + B) ÷ 2 = <b>11'-0"</b> (3353)	50	48	41	33	29	24	22											
	(A + B) ÷ 2 = <b>10'-6"</b> (3200)	50	48	41	33	29	24	22											
	(A + B) ÷ 2 = <b>10'-0"</b> (3048)	50	48	41	33	29	24	22											
	(A + B) ÷ 2 = <b>9'-6"</b> (2896)	50	48	41	33	29	24	22											
	(A + B) ÷ 2 = <b>9'-0"</b> (2743)	50	48	41	33	29	24	22											
	(A + B) ÷ 2 = <b>8'-6"</b> (2591)	50	48	41	33	29	24	22											
	(A + B) ÷ 2 = <b>8'-0"</b> (2438)	50	48	41	33	29	24	22											
	(A + B) ÷ 2 = <b>7'-6"</b> (2286)	50	48	41	33	29	24	22											
	(A + B) ÷ 2 = <b>7'-0"</b> (2134)	50	48	41	33	29	24	22											
	(A + B) ÷ 2 = <b>6'-6"</b> (1981)	50	48	41	33	29	25	23	20										
	(A + B) ÷ 2 = <b>6'-0"</b> (1829)	50	48	41	33	29	25	23	20										
	(A + B) ÷ 2 = <b>5'-6"</b> (1676)	50	48	41	33	30	26	24	21										
	(A + B) ÷ 2 = <b>5'-0"</b> (1524)	50	48	41	34	31	27	24	22	20									
	(A + B) ÷ 2 = <b>4'-6"</b> (1372)	50	48	42	36	32	28	26	23	22									
	(A + B) ÷ 2 = <b>4'-0"</b> (1219)	50	49	43	37	34	30	28	25	23	21								
(A + B) ÷ 2 = <b>3'-6"</b> (1067)	50	50	47	40	37	33	31	28	26	24	23	20							
(A + B) ÷ 2 = <b>3'-0"</b> (914)	50	50	50	44	40	36	33	30	29	26	25	22	20						
(A + B) ÷ 2 = <b>2'-6"</b> (762)	50	50	50	50	47	42	39	36	34	31	30	26	24	21	20				
(A + B) ÷ 2 = <b>2'-0"</b> (610)	50	50	50	50	50	49	46	42	40	37	35	31	31	27	25	22			
(A + B) ÷ 2 = <b>1'-6"</b> (457)	50	50	50	50	50	50	50	50	50	49	47	44	41	37	34	30	26		
<b>C = (length of join)</b>	<b>4'-6"</b> (1372) or less	<b>5'-0"</b> (1524)	<b>5'-6"</b> (1676)	<b>6'-0"</b> (1829)	<b>6'-6"</b> (1981)	<b>7'-0"</b> (2134)	<b>7'-6"</b> (2286)	<b>8'-0"</b> (2438)	<b>8'-6"</b> (2591)	<b>9'-0"</b> (2743)	<b>9'-6"</b> (2896)	<b>10'-0"</b> (3048)	<b>10'-6"</b> (3200)	<b>11'-0"</b> (3353)	<b>11'-6"</b> (3505)	<b>12'-0"</b> (3658)	<b>12'-6"</b> (3810)		

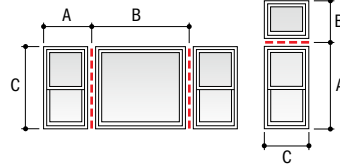

Note: Only one-way combinations similar to those shown above are allowed.

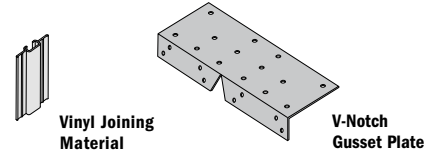

### One-Way or Two-Way Steel Joining with V-Notch Gusset Plates

400 Series Woodwright Double-Hung, Picture and Transom Full-Frame Windows & Tilt-Wash Double-Hung, Picture and Transom Full-Frame Windows

Average Adjacent Window Dimension	(A + B) ÷ 2 = <b>7'-6"</b> (2286)	50	40	35	30	27	23	21											
	(A + B) ÷ 2 = <b>7'-0"</b> (2134)	50	40	35	30	27	23	21											
	(A + B) ÷ 2 = <b>6'-6"</b> (1981)	50	40	35	30	27	24	22	20										
	(A + B) ÷ 2 = <b>6'-0"</b> (1829)	50	40	36	30	28	24	23	20										
	(A + B) ÷ 2 = <b>5'-6"</b> (1676)	50	41	36	31	29	26	24	21	20									
	(A + B) ÷ 2 = <b>5'-0"</b> (1524)	50	42	37	32	30	27	25	22	21									
	(A + B) ÷ 2 = <b>4'-6"</b> (1372)	50	43	39	34	32	28	27	24	23	21								
	(A + B) ÷ 2 = <b>4'-0"</b> (1219)	50	45	41	36	34	30	28	26	25	22	21							
	(A + B) ÷ 2 = <b>3'-6"</b> (1067)	50	50	45	40	37	34	32	29	28	26	24	20						
	(A + B) ÷ 2 = <b>3'-0"</b> (914)	50	50	50	44	41	37	35	32	30	28	26	22						
	(A + B) ÷ 2 = <b>2'-6"</b> (762)	50	50	50	50	48	44	41	38	36	34	31	26	23					
	(A + B) ÷ 2 = <b>2'-0"</b> (610)	50	50	50	50	50	50	48	44	41	38	36	34	30	24	21			
<b>C = (length of join)</b>	<b>5'-6"</b> (1676) or less	<b>6'-0"</b> (1829)	<b>6'-6"</b> (1981)	<b>7'-0"</b> (2134)	<b>7'-6"</b> (2286)	<b>8'-0"</b> (2438)	<b>8'-6"</b> (2591)	<b>9'-0"</b> (2743)	<b>9'-6"</b> (2896)	<b>10'-0"</b> (3048)	<b>10'-6"</b> (3200)	<b>11'-0"</b> (3353)	<b>11'-6"</b> (3505)	<b>12'-0"</b> (3658)	<b>12'-6"</b> (3810)				

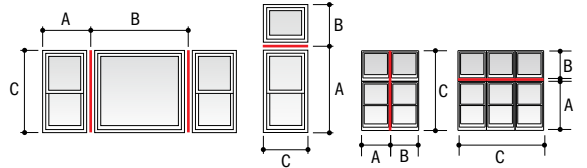

4" (102) x 3/16" (5)  
Steel Joining Material

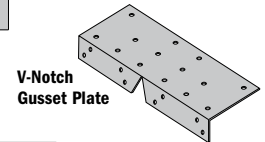

• Numerical values in charts represent structural pressure only.  
 • Dimensions in parentheses are in millimeters.  
 • Structural performance of any combination is only as high as the lowest structural performance of any individual unit or joining material in the combination.  
 • Andersen® products must be installed and anchored properly according to joining and installation guides to meet rated structural performance. Refer to product joining and installation guides at andersenwindows.com.  
 • Additional wind load tables are available at andersenwindows.com.

## Double-Hung Full-Frame Windows

### One-Way LVL Joining

400 Series Woodwright® Double-Hung, Picture and Transom Full-Frame Windows,  
Tilt-Wash Double-Hung, Picture and Transom Full-Frame Windows & Flexiframe® Windows

<b>4 9/16" (116) LVL</b>	Average Adjacent Window Dimension	(A + B) ÷ 2 = <b>6'-0"</b> (1829)	50	50	50	50	40	32	
		(A + B) ÷ 2 = <b>5'-6"</b> (1676)	50	50	50	50	42	33	
		(A + B) ÷ 2 = <b>5'-0"</b> (1524)	50	50	50	50	43	35	
		(A + B) ÷ 2 = <b>4'-6"</b> (1372)	50	50	50	50	46	38	
		(A + B) ÷ 2 = <b>4'-0"</b> (1219)	50	50	50	50	49	39	
		(A + B) ÷ 2 = <b>3'-6"</b> (1067)	50	50	50	50	50	44	
		(A + B) ÷ 2 = <b>3'-0"</b> (914)	50	50	50	50	50	48	
		(A + B) ÷ 2 = <b>2'-6"</b> (762)	50	50	50	50	50	50	
		(A + B) ÷ 2 = <b>2'-0"</b> (610)	50	50	50	50	50	50	
		(A + B) ÷ 2 = <b>1'-6"</b> (457)	50	50	50	50	50	50	
		(A + B) ÷ 2 = <b>1'-0"</b> (305)	50	50	50	50	50	50	
		<b>C = (length of join)</b>	<b>5'-6"</b> (1676) or less	<b>6'-0"</b> (1829)	<b>6'-6"</b> (1981)	<b>7'-0"</b> (2134)	<b>7'-6"</b> (2286)	<b>8'-0"</b> (2438)	

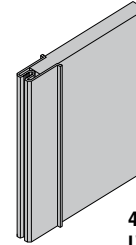
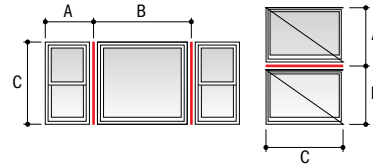

**4 9/16" (116) x 3/4" (19) LVL Joining Material**

### Two-Way LVL Joining

400 Series Woodwright Double-Hung, Picture and Transom Full-Frame Windows,  
Tilt-Wash Double-Hung, Picture and Transom Full-Frame Windows & Flexiframe Windows

<b>6 9/16" (167) LVL</b>	Average Adjacent Window Dimension	(A + B) ÷ 2 = <b>10'-0"</b> (3048)	50	50	50	50	48	44	37	31	24
		(A + B) ÷ 2 = <b>9'-6"</b> (2896)	50	50	50	50	48	44	37	31	24
		(A + B) ÷ 2 = <b>9'-0"</b> (2743)	50	50	50	50	48	44	37	31	24
		(A + B) ÷ 2 = <b>8'-6"</b> (2591)	50	50	50	50	48	44	37	31	25
		(A + B) ÷ 2 = <b>8'-0"</b> (2438)	50	50	50	50	48	44	37	31	25
		(A + B) ÷ 2 = <b>7'-6"</b> (2286)	50	50	50	50	48	44	38	32	26
		(A + B) ÷ 2 = <b>7'-0"</b> (2134)	50	50	50	50	49	45	39	33	26
		(A + B) ÷ 2 = <b>6'-6"</b> (1981)	50	50	50	50	50	46	40	34	28
		(A + B) ÷ 2 = <b>6'-0"</b> (1829)	50	50	50	50	50	47	41	35	29
		(A + B) ÷ 2 = <b>5'-6"</b> (1676)	50	50	50	50	50	50	44	37	30
		(A + B) ÷ 2 = <b>5'-0"</b> (1524)	50	50	50	50	50	50	46	39	32
		(A + B) ÷ 2 = <b>4'-6"</b> (1372)	50	50	50	50	50	50	50	43	35
		(A + B) ÷ 2 = <b>4'-0"</b> (1219)	50	50	50	50	50	50	50	46	38
		(A + B) ÷ 2 = <b>3'-6"</b> (1067)	50	50	50	50	50	50	50	50	42
		(A + B) ÷ 2 = <b>3'-0"</b> (914)	50	50	50	50	50	50	50	50	47
		(A + B) ÷ 2 = <b>2'-6"</b> (762)	50	50	50	50	50	50	50	50	50
		(A + B) ÷ 2 = <b>2'-0"</b> (610)	50	50	50	50	50	50	50	50	50
	(A + B) ÷ 2 = <b>1'-6"</b> (457)	50	50	50	50	50	50	50	50	50	
	<b>C = (length of join)</b>	<b>6'-0"</b> (1829) or less	<b>6'-6"</b> (1981)	<b>7'-0"</b> (2134)	<b>7'-6"</b> (2286)	<b>8'-0"</b> (2438)	<b>8'-6"</b> (2591)	<b>9'-0"</b> (2743)	<b>9'-6"</b> (2896)	<b>10'-0"</b> (3048)	

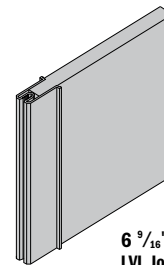
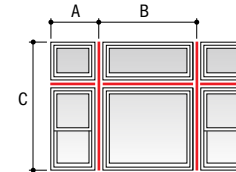

**6 9/16" (167) x 3/4" (19) LVL Joining Material**

**Note:** Two-way joining must be assembled on the jobsite within the rough opening. When creating two-way combinations for 6 9/16" (167) minimum wall thickness, 6 9/16" (167) LVL joining material is required.

• Numerical values in charts represent structural pressure only.  
• Dimensions in parentheses are in millimeters.  
• Structural performance of any combination is only as high as the lowest structural performance of any individual unit or joining material in the combination.  
• Andersen® products must be installed and anchored properly according to joining and installation guides to meet rated structural performance. Refer to product joining and installation guides at andersenwindows.com.  
• Additional wind load tables are available at andersenwindows.com.

# COMBINATION DESIGNS

## Gliding Patio Doors

### One-Way Jamb-to-Jamb Joining

400 Series Stationary and Two-Panel Frenchwood® Gliding Patio Doors

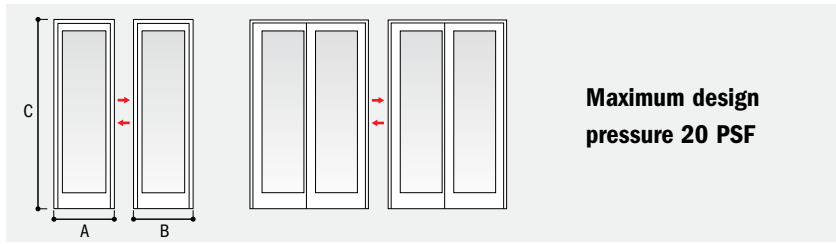

### One-Way Jamb-to-Jamb Vertical (Ribbon) Joining

400 Series Stationary and Two-Panel Frenchwood Gliding Patio Doors & Frenchwood® Patio Door Sidelights

(A + B) ÷ 2 = 8'-0" (2438)	65	65	65	65	61	51	44	37	33	29
(A + B) ÷ 2 = 7'-6" (2286)	65	65	65	65	61	51	44	37	33	29
(A + B) ÷ 2 = 7'-0" (2134)	65	65	65	65	61	51	44	37	33	29
(A + B) ÷ 2 = 6'-6" (1981)	65	65	65	65	61	51	44	38	33	30
(A + B) ÷ 2 = 6'-0" (1829)	65	65	65	65	61	51	44	38	34	31
(A + B) ÷ 2 = 5'-6" (1676)	65	65	65	65	61	52	45	39	35	32
(A + B) ÷ 2 = 5'-0" (1524)	65	65	65	65	62	53	46	41	37	33
(A + B) ÷ 2 = 4'-6" (1372)	65	65	65	65	63	55	48	43	39	35
(A + B) ÷ 2 = 4'-0" (1219)	65	65	65	65	65	58	51	46	42	38
(A + B) ÷ 2 = 3'-6" (1067)	65	65	65	65	65	62	55	50	46	42
(A + B) ÷ 2 = 3'-0" (914)	65	65	65	65	65	65	62	56	51	47
(A + B) ÷ 2 = 2'-6" (762)	65	65	65	65	65	65	65	64	59	55
(A + B) ÷ 2 = 2'-0" (610)	65	65	65	65	65	65	65	65	65	65
(A + B) ÷ 2 = 1'-6" (457)	65	65	65	65	65	65	65	65	65	65
<b>C = (length of join)</b>	<b>3'-6"</b> (1067)	<b>4'-0"</b> (1219)	<b>4'-6"</b> (1372)	<b>5'-0"</b> (1524)	<b>5'-6"</b> (1676)	<b>6'-0"</b> (1829)	<b>6'-6"</b> (1981)	<b>7'-0"</b> (2134)	<b>7'-6"</b> (2286)	<b>8'-0"</b> (2438)

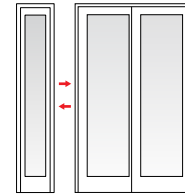

### One-Way Jamb-to-Jamb Horizontal (Stacked) Joining

400 Series Stationary and Two-Panel Frenchwood Gliding Patio Doors & Frenchwood Patio Door Transoms

(A + B) ÷ 2 = 12'-6" (3810)	65	65	65	65	52	40	31	25		
(A + B) ÷ 2 = 12'-0" (3658)	65	65	65	65	52	40	31	25		
(A + B) ÷ 2 = 11'-6" (3505)	65	65	65	65	52	40	31	25		
(A + B) ÷ 2 = 11'-0" (3353)	65	65	65	65	52	40	31	25		
(A + B) ÷ 2 = 10'-6" (3200)	65	65	65	65	52	40	31	25		
(A + B) ÷ 2 = 10'-0" (3048)	65	65	65	65	52	40	31	25		
(A + B) ÷ 2 = 9'-6" (2896)	65	65	65	65	52	40	31	25		
(A + B) ÷ 2 = 9'-0" (2743)	65	65	65	65	52	40	31	25		
(A + B) ÷ 2 = 8'-6" (2591)	65	65	65	65	52	40	31	25		
(A + B) ÷ 2 = 8'-0" (2438)	65	65	65	65	52	40	31	25		
(A + B) ÷ 2 = 7'-6" (2286)	65	65	65	65	52	40	31	25		
(A + B) ÷ 2 = 7'-0" (2134)	65	65	65	65	52	40	31	25		
(A + B) ÷ 2 = 6'-6" (1981)	65	65	65	65	52	40	31	25		
(A + B) ÷ 2 = 6'-0" (1829)	65	65	65	65	52	40	32	25	20	
(A + B) ÷ 2 = 5'-6" (1676)	65	65	65	65	52	40	32	26	20	
(A + B) ÷ 2 = 5'-0" (1524)	65	65	65	65	53	41	34	28	22	
(A + B) ÷ 2 = 4'-6" (1372)	65	65	65	65	54	44	36	29	23	
(A + B) ÷ 2 = 4'-0" (1219)	65	65	65	65	58	47	39	32	25	21
(A + B) ÷ 2 = 3'-6" (1067)	65	65	65	65	63	51	43	35	28	23
(A + B) ÷ 2 = 3'-0" (914)	65	65	65	65	65	58	49	40	32	26
(A + B) ÷ 2 = 2'-6" (762)	65	65	65	65	65	65	57	47	38	31
(A + B) ÷ 2 = 2'-0" (610)	65	65	65	65	65	65	65	58	47	38
(A + B) ÷ 2 = 1'-6" (457)	65	65	65	65	65	65	65	65	62	51
<b>C = (length of join)</b>	<b>3'-6"</b> (1067)	<b>4'-0"</b> (1219)	<b>4'-6"</b> (1372)	<b>5'-0"</b> (1524)	<b>5'-6"</b> (1676)	<b>6'-0"</b> (1829)	<b>6'-6"</b> (1981)	<b>7'-0"</b> (2134)	<b>7'-6"</b> (2286)	<b>8'-0"</b> (2438)

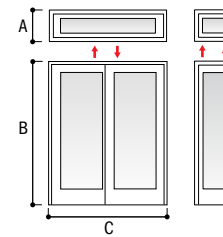

- Numerical values in charts represent structural pressure only.
- Dimensions in parentheses are in millimeters.
- Structural performance of any combination is only as high as the lowest structural performance of any individual unit or joining material in the combination.
- Andersen® products must be installed and anchored properly according to joining and installation guides to meet rated structural performance. Refer to product joining and installation guides at [andersenwindows.com](http://andersenwindows.com).
- Additional wind load tables are available at [andersenwindows.com](http://andersenwindows.com).

**Hinged Patio Doors**

**One-Way Aluminum Joining**

400 Series Frenchwood® Hinged Inswing Patio Doors & Frenchwood® Patio Doors Sidelights and Transoms

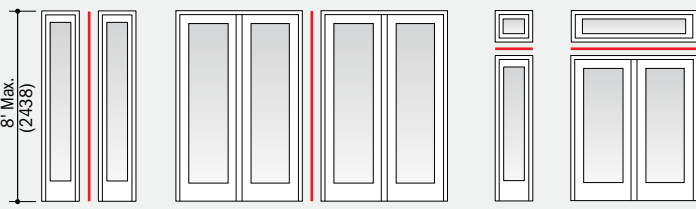

**One-Way  
Maximum design  
pressure 25 PSF**

Note: When joining hinged inswing patio doors, do not join hinge jamb to hinge jamb.

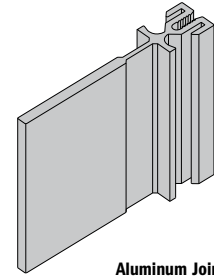

Aluminum Joining Material

**Two-Way Aluminum Joining**

400 Series Frenchwood Hinged Inswing Patio Doors & Frenchwood Patio Door Sidelights and Transoms

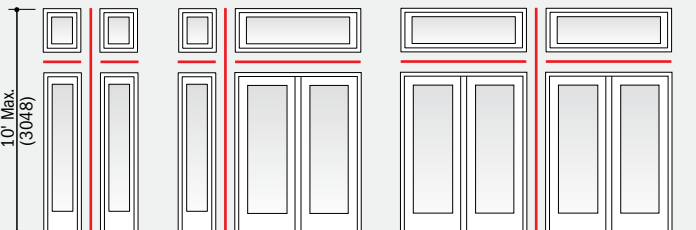

**Two-Way  
Maximum design  
pressure 20 PSF**

Note: When joining hinged inswing patio doors, do not join hinge jamb to hinge jamb.

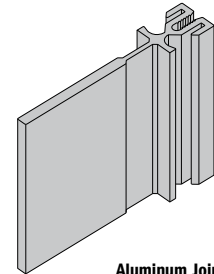

Aluminum Joining Material

Combination Design,  
Product Performance  
& Installation

**Gliding & Hinged Patio Doors**

**One-Way LVL Joining**

400 Series Frenchwood Gliding, Frenchwood Hinged Inswing Patio Doors & Frenchwood Patio Door Sidelights and Transoms

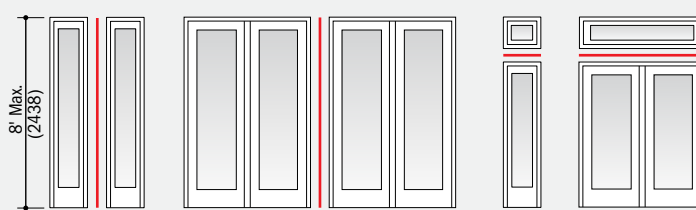

**Maximum rating for 4 9/16" (116)  
LVL is equivalent to +62/-77 PSF**

Note: When joining hinged inswing patio doors, do not join hinge jamb to hinge jamb.

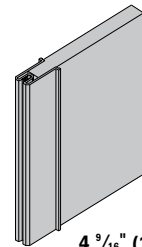

4 9/16" (116) x 3/4" (19)  
LVL Joining Material

- Dimensions in parentheses are in millimeters.
- Structural performance of any combination is only as high as the lowest structural performance of any individual unit or joining material in the combination.
- Andersen® products must be installed and anchored properly according to joining and installation guides to meet rated structural performance. Refer to product joining and installation guides at andersenwindows.com.
- Additional wind load tables are available at andersenwindows.com.

# COMBINATION DESIGNS

## Gliding & Hinged Patio Doors

### Two-Way LVL Joining

400 Series Frenchwood® Gliding, Frenchwood® Hinged Inswing Patio Doors & Frenchwood® Patio Door Sidelights and Transoms

<b>4 9/16" (116) LVL</b>	Average Adjacent Door/Transom/Sidelight Dimension	(A + B) ÷ 2 = 8'-0" (2438)	30	27	25	23	21	20				
		(A + B) ÷ 2 = 7'-9" (2362)	31	29	26	24	22	21				
		(A + B) ÷ 2 = 7'-6" (2286)	32	29	27	25	23	21				
		(A + B) ÷ 2 = 7'-3" (2210)	33	30	27	25	23	21	20			
		(A + B) ÷ 2 = 7'-0" (2134)	34	31	29	24	24	22	21			
		(A + B) ÷ 2 = 6'-9" (2057)	35	32	29	27	25	23	21			
		(A + B) ÷ 2 = 6'-6" (1981)	36	33	31	28	26	24	22	20		
		(A + B) ÷ 2 = 6'-3" (1905)	37	34	31	29	27	25	23	21		
		(A + B) ÷ 2 = 6'-0" (1829)	39	35	33	30	27	25	23	22	20	
		(A + B) ÷ 2 = 5'-9" (1753)	40	37	34	31	29	27	25	23	21	
		(A + B) ÷ 2 = 5'-6" (1676)	42	38	35	33	30	27	25	23	22	20
		(A + B) ÷ 2 = 5'-3" (1600)	43	40	37	34	31	29	27	25	23	21
		(A + B) ÷ 2 = 5'-0" (1524)	45	42	39	35	33	30	27	25	23	22
		(A + B) ÷ 2 = 4'-9" (1448)	47	44	40	37	34	31	29	27	25	23
		(A + B) ÷ 2 = 4'-6" (1372)	50	46	42	39	35	33	30	28	26	24
		(A + B) ÷ 2 = 4'-3" (1295)	53	49	45	41	37	35	32	29	27	25
		(A + B) ÷ 2 = 4'-0" (1219)	56	51	47	43	39	37	33	31	29	27
		(A + B) ÷ 2 = 3'-9" (1143)	59	54	50	46	42	39	35	33	30	28
		(A + B) ÷ 2 = 3'-6" (1067)	63	57	53	49	45	41	38	35	32	30
		(A + B) ÷ 2 = 3'-3" (991)	67	62	57	52	48	44	41	37	33	32
(A + B) ÷ 2 = 3'-0" (914)	73	67	61	56	51	47	43	40	37	34		
<b>C = (length of join)</b>	<b>7'-9" (2362)</b>	<b>8'-0" (2438)</b>	<b>8'-3" (2515)</b>	<b>8'-6" (2591)</b>	<b>8'-9" (2667)</b>	<b>9'-0" (2743)</b>	<b>9'-3" (2819)</b>	<b>9'-6" (2896)</b>	<b>9'-9" (2972)</b>	<b>10'-0" (3048)</b>		

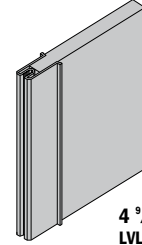

4 9/16" (116) x 3/4" (19) LVL Joining Material

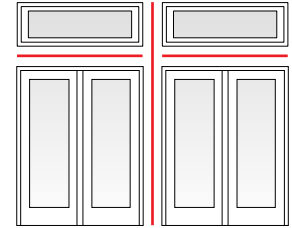
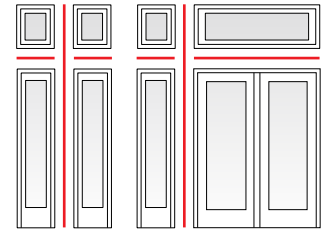

<b>6 9/16" (167) LVL</b>	Average Adjacent Door/Transom/Sidelight Dimension	(A + B) ÷ 2 = 8'-0" (2438)	45	43	43	41	41	40	37	36	35	35	
		(A + B) ÷ 2 = 7'-9" (2362)	46	45	44	43	42	41	38	37	37	37	35
		(A + B) ÷ 2 = 7'-6" (2286)	47	46	45	44	43	42	39	38	38	37	37
		(A + B) ÷ 2 = 7'-3" (2210)	49	47	47	45	44	43	40	39	39	39	38
		(A + B) ÷ 2 = 7'-0" (2134)	50	49	48	47	45	45	41	41	41	40	39
		(A + B) ÷ 2 = 6'-9" (2057)	51	51	49	48	47	46	43	42	42	41	40
		(A + B) ÷ 2 = 6'-6" (1981)	53	52	51	50	49	47	44	43	43	42	41
		(A + B) ÷ 2 = 6'-3" (1905)	55	54	53	51	50	49	46	45	44	44	43
		(A + B) ÷ 2 = 6'-0" (1829)	57	56	55	53	52	51	47	47	47	45	45
		(A + B) ÷ 2 = 5'-9" (1753)	59	58	57	55	54	53	49	49	49	47	47
		(A + B) ÷ 2 = 5'-6" (1676)	62	61	59	57	56	55	51	51	51	49	49
		(A + B) ÷ 2 = 5'-3" (1600)	65	63	61	60	59	57	53	53	53	51	51
		(A + B) ÷ 2 = 5'-0" (1524)	67	66	64	63	61	60	56	55	55	54	53
		(A + B) ÷ 2 = 4'-9" (1448)	71	69	67	65	64	63	59	57	57	57	55
		(A + B) ÷ 2 = 4'-6" (1372)	74	73	71	69	67	65	62	61	59	59	58
		(A + B) ÷ 2 = 4'-3" (1295)	77	76	75	73	71	69	65	64	63	63	61
		(A + B) ÷ 2 = 4'-0" (1219)	77	77	77	77	75	73	69	67	66	66	65
		(A + B) ÷ 2 = 3'-9" (1143)	77	77	77	77	77	77	73	72	70	69	69
		(A + B) ÷ 2 = 3'-6" (1067)	77	77	77	77	77	77	77	76	75	73	73
		(A + B) ÷ 2 = 3'-3" (991)	77	77	77	77	77	77	77	77	77	77	77
(A + B) ÷ 2 = 3'-0" (914)	77	77	77	77	77	77	77	77	77	77	77		
<b>C = (length of join)</b>	<b>7'-9" (2362)</b>	<b>8'-0" (2438)</b>	<b>8'-3" (2515)</b>	<b>8'-6" (2591)</b>	<b>8'-9" (2667)</b>	<b>9'-0" (2743)</b>	<b>9'-3" (2819)</b>	<b>9'-6" (2896)</b>	<b>9'-9" (2972)</b>	<b>10'-0" (3048)</b>			

Note: When joining hinged inswing patio doors, do not join hinge jamb to hinge jamb.

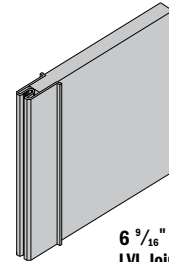

6 9/16" (167) x 3/4" (19) LVL Joining Material

- Numerical values in charts represent structural pressure only.
- Dimensions in parentheses are in millimeters.
- Structural performance of any combination is only as high as the lowest structural performance of any individual unit or joining material in the combination.
- Andersen® products must be installed and anchored properly according to joining and installation guides to meet rated structural performance. Refer to product joining and installation guides at [andersenwindows.com](http://andersenwindows.com).
- Additional wind load tables are available at [andersenwindows.com](http://andersenwindows.com).

Patio Doors & Windows

One-Way Steel Joining  
400 Series Patio Doors and Windows

(A + B) + 2 = 12'-6" (3810)	40	37	33	25	22											
(A + B) + 2 = 12'-0" (3658)	40	37	34	26	23											
(A + B) + 2 = 11'-6" (3505)	40	38	35	27	24											
(A + B) + 2 = 11'-0" (3353)	40	39	36	29	25											
(A + B) + 2 = 10'-6" (3200)	40	40	37	30	27	21										
(A + B) + 2 = 10'-0" (3048)	40	40	37	32	28	22										
(A + B) + 2 = 9'-6" (2896)	40	40	39	34	30	23	20									
(A + B) + 2 = 9'-0" (2743)	40	40	40	36	32	25	21									
(A + B) + 2 = 8'-6" (2591)	40	40	40	37	34	27	22									
(A + B) + 2 = 8'-0" (2438)	40	40	40	39	36	28	24									
(A + B) + 2 = 7'-6" (2286)	40	40	40	40	37	31	27	21								
(A + B) + 2 = 7'-0" (2134)	40	40	40	40	40	32	28	22								
(A + B) + 2 = 6'-6" (1981)	40	40	40	40	40	36	31	25	23							
(A + B) + 2 = 6'-0" (1829)	40	40	40	40	40	39	36	27	24	20						
(A + B) + 2 = 5'-6" (1676)	40	40	40	40	40	40	37	30	25	24						
(A + B) + 2 = 5'-0" (1524)	40	40	40	40	40	40	40	36	28	25						
(A + B) + 2 = 4'-6" (1372)	40	40	40	40	40	40	40	40	37	31	27	23	20			
(A + B) + 2 = 4'-0" (1219)	40	40	40	40	40	40	40	40	40	37	30	26	25	21		
(A + B) + 2 = 3'-6" (1067)	40	40	40	40	40	40	40	40	40	40	36	27	26	25		
(A + B) + 2 = 3'-0" (914)	40	40	40	40	40	40	40	40	40	40	40	36	30	26	23	
(A + B) + 2 = 2'-6" (762)	40	40	40	40	40	40	40	40	40	40	40	40	38	34	26	20
(A + B) + 2 = 2'-0" (610)	40	40	40	40	40	40	40	40	40	40	40	40	40	40	34	28
<b>C = (length of join)</b>	<b>5'-6"</b> (1676) or less	<b>6'-0"</b> (1829)	<b>6'-6"</b> (1981)	<b>7'-0"</b> (2134)	<b>7'-6"</b> (2286)	<b>8'-0"</b> (2438)	<b>8'-6"</b> (2591)	<b>9'-0"</b> (2743)	<b>9'-6"</b> (2896)	<b>10'-0"</b> (3048)	<b>10'-6"</b> (3200)	<b>11'-0"</b> (3353)	<b>11'-6"</b> (3505)	<b>12'-0"</b> (3658)	<b>12'-6"</b> (3810)	

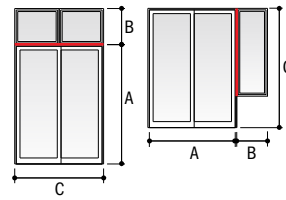

4" (102) x 3/16" (5)  
Steel Joining Material

**Intended for use with patio door to window joins only.** Please refer to patio door tables for further information regarding structural support between doors. When using exterior extension jambs on Frenchwood® hinged patio doors, special conditions apply. For complete installation details visit [andersenwindows.com](http://andersenwindows.com).

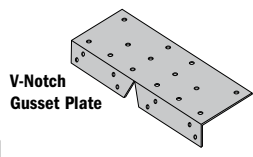

Combination Design, Product Performance & Installation

Figure 1

Andersen recommends use of a separating structural header between the door head and sill of any transom unit(s). If you choose not to use a header, and a single row of transom units is desired above the door, make sure the units are securely fastened to the adjacent framing and securely "hung" by screwing through the transom unit frame(s) into the header above. Steel joining may be required.

**IMPORTANT: HEADER SAG MAY ADVERSELY AFFECT THE PROPER FUNCTIONING AND PERFORMANCE OF THE DOOR AND/OR WINDOW.** No weight from the transom unit(s) may be transferred to the door head if proper operation of the door is to be achieved. For four-panel gliding patio doors, see Figure 3.

Figure 2

Any transom combination made up of more than a single row of windows must have a separating header (by others).

Figure 3

Always use a structural header to separate transom windows from four-panel gliding patio doors. For all other door types, see Figure 1.

Figure 4

Steel reinforcing is recommended whenever transom or sidelight windows are placed above or beside door units.

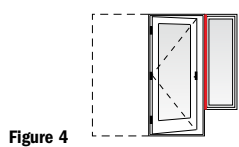
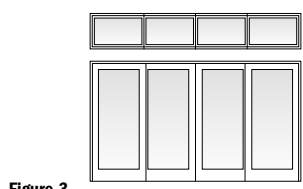
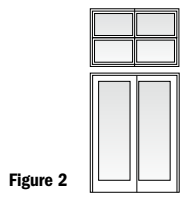
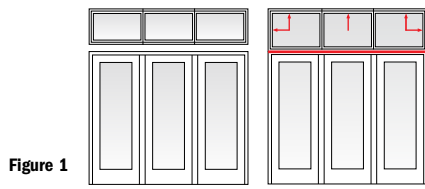

\* Numerical values in charts represent structural pressure only.  
 \* Dimensions in parentheses are in millimeters.  
 \* Structural performance of any combination is only as high as the lowest structural performance of any individual unit or joining material in the combination.  
 \* Andersen® products must be installed and anchored properly according to joining and installation guides to meet rated structural performance. Refer to product joining and installation guides at [andersenwindows.com](http://andersenwindows.com).  
 \* Additional wind load tables are available at [andersenwindows.com](http://andersenwindows.com).

# PRODUCT PERFORMANCE

## Andersen® 400 Series Window and Patio Door Altitude Limits

The chart below gives the altitude limit in feet for most 400 Series products in this catalog. If the installation of a given product is at an altitude greater than that shown in this chart, a capillary breather tube must be ordered. Be aware that the use of a capillary breather tube eliminates argon gas blend fill and will result in a slightly lower thermal performance (approximately 0.02 increase in window U-Factor). For NFRC certified total unit performance on units with capillary breather tubes for higher altitude applications, please visit [andersenwindows.com/nfrc](http://andersenwindows.com/nfrc).

The use of dual-pane insulating glass without capillary breather tubes at altitudes higher than its rating will result in severe glass distortion, increased glass breakage potential and a risk for seal failure.

Smaller windows are most affected by altitude changes. An increase in altitude results in a decrease in atmospheric pressure. A sealed insulating glass unit attempts to combat this change by increasing its volume to reduce its pressure. One way to increase its volume is by glass deflection. A smaller window is stiffer and does not deflect as much as a larger window; therefore, it cannot relieve the pressure as readily. Thus, the load applied to the glass is greater, resulting in a greater risk for breakage. Another way the window tries to increase its volume is by increasing the edge area; i.e. the seal area. The increased pressure applied to the edge seal load for a smaller window is therefore greater, increasing the chance for seal failure.

Product	2,000	3,000	4,000	5,000	6,000	7,000	8,000	9,000	10,000				
Casement & Awning Windows				CR12 CN12 CR13 CN13 CR135 CN135 CR14 CN14 CR15 CN145 CR16 CN15 CR45 CN155 CR155 CN16 CR125 AN251	C12 C14 AN251 C15 C13 C155 C135 C16 C145 CW12		CW13 CW145 CW135 CW15 CW14 CW155 CX125 CW16 AX251 AW251 CW125 AW281 CXW125	CX13 AXW281 CX135 AX31 CX14 AX351 CX145 AX41 CX15 AX451 CX155 AX51 CX16 AX551 AX61	A335/CP353 CXW45 CP3535 CXW5/CP305 CXW3/CP303 CXW155 CXW35 CXW6 CXW4				
			4,000						10,000				
Casement/Awning Transom & Picture Windows		CTR1510 CTR1810 CTR2010 CTR2410 CTR2810	CTR3010 CTR2910 CTR3410 CTR4010 CTR4810	CTR5010 CTR5210 CTR51110 CTR6010 CTR7010				P3030 P3050 P3035 P3055 P3040 P3060 P3045	P3535 P5050 P3540 P3555 P3545 P3560 P3550 P4040	P4045 P4060 P4050 P4545 P5055 P4550 P4055 P4555			
Woodwright® Double-Hung Windows			18210 34210 20210 28210 24210 210210 30210 38210 26210	1832 3032 1836 3036 18310 3832 1842 1862 2632 1856C 2636 2032 2832 2036 3436 2432 1846 2836 18410 3432 1852 21032 1856E 3836 18510 2436 21036	20310 2056C 2042 3442 2046 38310 20410 3842 210310 24310 21042 2442 30310 26310 3042 2642 2052 28310 2056E 34310 20510 2842 2062	2446 2646 24410 2846 2452 21046 2456E 3046 24510 3048 2462 3446 2456C 3846	26410 28410 2652 2852 2656E 2856E 26510 28510 3052 2862 34410 2856C 3452 210410 38410 21052 2662 3852 2656C 30410	21056E 3056E 210510 3456E 21062 3856E 21056C	30510 3456C 3062 38510 3056C 3862 34510 3856C 3462				
	E = equal sash C = cottage sash  Designate product code as WDH, WU, WH or WA.		4,000										
Woodwright® Transom Windows		WTR1810 WTR1815 WTR1817 WTR18111 WTR18121 WTR31010 WTR2815 WTR2817 WTR3010 WTR3015 WTR3017 WTR6217	WTR4210 WTR3410 WTR41010 WTR1823 WTR1827 WTR1831 WTR2010 WTR2015 WTR2015 WTR3415 WTR3417 WTR3810 WTR3815 WTR3817	WTR31015 WTR4217 WTR41017 WTR6210 WTR5617 WTR2410 WTR2415 WTR2417 WTR2810 WTR41015 WTR5615 WTR6215	WTR28121 WTR30111 WTR31021 WTR4221 WTR41021 WTR5621 WTR6221 WTR30121 WTR34111 WTR34121 WTR38111 WTR38121 WTR28111	WTR2423 WTR31023 WTR4223 WTR41023 WTR5623 WTR6223	WTR2827 WTR31027 WTR2831 WTR4227 WTR3027 WTR3427 WTR3827	WTR3031 WTR3431 WTR3831	WTR31031 WTR4231 WTR41031 WTR5631 WTR6231				
		WPW10310 WPW1042 WPW1046 WPW10410 WPW1052 WPW1056 WPW10510 WPW1062		5,000	6,000	7,000	8,000	9,000					
Woodwright® Picture Windows													
Tilt-Wash Double-Hung Windows		TW18210 TW1832 TW1836 TW18310 TW2432 TW26210 TW2632 TW28210	TW2828 TW1842 TW1846 TW18410 TW1852 TW1856E TW2832 TW210210	TW21032 TW3432 TW30210 TW18510 TW1862 TW1856C TW1872 TW1876	TW34210 TW20310 TW2052 TW2056E TW2046 TW28310 TW21036 TW21036 TW2072	TW20410 TW2056C TW2436 TW20510 TW2062 TW3436 TW34310 TW30310 TW2836 TW2076	TW2442 TW2446 TW2842 TW21042 TW3042 TW3442 TW3842	TW2646 TW2846 TW21046 TW3046 TW3048 TW3446 TW3846	TW26410 TW2656C TW28410 TW2852 TW2876 TW3052 TW34410 TW3452 TW38410 TW30410 TW2662	TW2672 TW2676 TW2872 TW2876 TW2876 TW3052 TW34410 TW3452 TW38410 TW3852 TW28510	TW21056E TW210510 TW21062 TW21056C TW3056E TW30510 TW3062 TW3056C	TW3456E TW34510 TW3462 TW3456C TW3856E TW38510 TW3862 TW3876	TW21072 TW21076 TW3072 TW3076 TW3472 TW3476 TW3872 TW3876
	E = equal sash C = cottage sash												

continued on next page

\* Deflection of glass will occur on units with larger glass areas. If interior/exterior grilles are used on double-hung windows, gliding windows or gliding patio doors, some interference may occur, affecting operation of these units.  
 \* Altitude limits for patio doors shown in two-panel configurations. These limits also qualify for same size panels used in one or multiple panel configurations.  
 • Contact your Andersen supplier for altitude limits for custom-sized windows and patio doors.



# PRODUCT PERFORMANCE

## PERFORMANCE STANDARDS

The Window and Door Manufacturers Association (WDMA), the American Architectural Manufacturers Association (AAMA) and the Canadian Standards Association (CSA) jointly release the North American Fenestration Standard/Specification for Windows, Doors and Skylights (NAFS-11) where "-11" refers to the most recent publication year of 2011. NAFS is also referred to as AAMA/WDMA/CSA 101/I.S.2/A440, which is how the International Code Council (ICC) lists this standard in the 2012 and 2015 International Residential Code (IRC) and International Building Code (IBC) as the means to indicate the window, door or skylights design pressure rating used to determine compliance to the jobsite design pressure requirements.

A product only achieves a "Performance Grade" or "PG" rating when it complies with all of the NAFS performance requirements such as ease of operation, air infiltration resistance, resistance to water penetration and resistance to forced entry, etc. A "Design Pressure Rating" or "DP" rating only depicts the design and structural load performance.

### Performance Classes

The NAFS Standard/Specification defines requirements for four performance classes. Performance classes are designated R, LC, CW, and AW. This classification system provides for several levels of performance. Product selection is always based on the performance and building code requirements of the particular project.

### Elements of Performance Grade (PG) Designations

In order to qualify for a given performance grade (PG), test specimens need to pass all required performance tests for the following, in addition to all required auxiliary (durability) and applicable material/component tests (not shown here) for the applicable product type and desired performance class:

- (a) Operating force (if applicable):** Maximum operating force varies by product type and performance class.
- (b) Air leakage resistance:** Tested in accordance with ASTM E283 at a test pressure of 1.57 psf. Allowable air infiltration for R, LC and CW class designations is 0.3 cubic feet per minute per square foot of frame (cfm/ft<sup>2</sup>).
- (c) Water penetration resistance:** Tested in accordance with ASTM E547 with the specified test pressure applied per NAFS-11. Test consists of four cycles. Each cycle consists of five minutes with pressure applied and one minute with the pressure released, during which the water spray is continuously applied. Water spray shall be uniformly applied at a constant rate of 5 U.S. gal/ft<sup>2</sup> · hr.
- (d) Uniform load deflection test:** Tested in accordance with ASTM E330 for both positive and negative pressure (pressure defined by NAFS-11) with the load maintained for a period of 10 seconds. The test specimen shall be evaluated for deflection during each load for permanent damage after each load and for any effects on the normal operation of the specimen. *Starting with the 2008 version of NAFS, design pressure (DP) will only represent the "uniform load deflection test".*
- (e) Uniform load structural test:** Tested in accordance with ASTM E330 for both positive and negative pressure (pressure defined by NAFS-11) with the load maintained for a period of 10 seconds. After loads are removed, there shall be no permanent deformation in excess of 0.4% of its span and no damage to the unit, which would make it inoperable.
- (f) Forced-entry resistance (if applicable):** Tested in accordance with ASTM F588 (windows), F476 (swinging doors) and F842 (sliding doors) at a performance level 10 rating.

### Performance Grades (PG) & Corresponding Test Pressures (psf)

Performance Class/ Performance Grade		Air Infiltration Test Pressure		Maximum Allowable Air Infiltration/ Exfiltration Rate		Water Penetration Resistance Test Pressure		Design Pressure		Structural Test Pressure	
R	LC	Pa	psf	L/s·m <sup>2</sup>	cfm/ft <sup>2</sup>	Pa	psf	Pa	psf	Pa	psf
15	-	75	1.57	1.5	0.30	140	2.92	720	15.04	1080	22.56
20	-	75	1.57	1.5	0.30	150	3.13	960	20.05	1440	30.08
25	25	75	1.57	1.5	0.30	180	3.76	1200	25.06	1800	37.59
30	30	75	1.57	1.5	0.30	220	4.59	1440	30.08	2160	45.11
35	35	75	1.57	1.5	0.30	260	5.43	1680	35.09	2520	52.63
40	40	75	1.57	1.5	0.30	290	6.06	1920	40.10	2880	60.15
45	45	75	1.57	1.5	0.30	330	6.89	2160	45.11	3240	67.67
50	50	75	1.57	1.5	0.30	360	7.52	2400	50.13	3600	75.19
55	55	75	1.57	1.5	0.30	400	8.35	2640	55.14	3960	82.71
60	60	75	1.57	1.5	0.30	440	9.19	2880	60.15	4320	90.23
65	65	75	1.57	1.5	0.30	470	9.82	3120	65.16	4680	97.74
70	70	75	1.57	1.5	0.30	510	10.65	3360	70.18	5040	105.26
75	75	75	1.57	1.5	0.30	540	11.28	3600	75.19	5400	112.78
80	80	75	1.57	1.5	0.30	580	12.11	3840	80.20	5760	120.30
85	85	75	1.57	1.5	0.30	580	12.11	4080	85.21	6120	127.82
90	90	75	1.57	1.5	0.30	580	12.11	4320	90.23	6480	135.34
95	95	75	1.57	1.5	0.30	580	12.11	4560	95.24	6840	142.86
100	100	75	1.57	1.5	0.30	580	12.11	4800	100.25	7200	150.38

## HALLMARK CERTIFICATION

The Window and Door Manufacturers Association (WDMA)-sponsored Hallmark Certification Program provides manufacturers with certification to the AAMA/WDMA/CSA 101/I.S.2/A440-11 Standard and is designed to provide builders, architects, specifiers and consumers with an easily recognizable means of identifying products that have been manufactured and tested in accordance with NAFS (AAMA/WDMA/CSA 101/I.S.2/A440) industry standards and other applicable performance standards. Conformance is determined by periodic in-plant inspections by a third-party administrator. Inspections include auditing licensee quality control procedures and processes and a review to confirm products are manufactured in accordance with the appropriate performance standards. Periodic testing of representative product constructions and components by an independent testing laboratory is also required. When all of the program requirements are met, the licensee is authorized to use the WDMA Hallmark registered logo on their certification label as a means of identifying products and their performance ratings.

Products successfully obtaining Hallmark Certification will be labeled with a 3-part code, which includes performance class, performance grade and size tested. In addition to this mandatory requirement, you are allowed to list the design pressure on a separate line.

	Andersen Corporation 400 SERIES CASEMENT WINDOW Manufacturer stipulates certification as indicated below.					
	<table border="1"> <thead> <tr> <th>STANDARD</th> <th>RATING</th> </tr> </thead> <tbody> <tr> <td>AAMA/WDMA/CSA 101/I.S.2/A440-11</td> <td>CLASS LC<sup>(1)</sup> - PG50<sup>(2)</sup> - SIZE TESTED 56 X 71.8 in.<sup>(3)</sup> DP+50/-50<sup>(4)</sup></td> </tr> <tr> <td>AAMA/WDMA/CSA 101/I.S.2/A440-08</td> <td>CLASS LC<sup>(1)</sup> - PG50<sup>(2)</sup> - SIZE TESTED 56 X 71.8 in.<sup>(3)</sup> DP+50/-50<sup>(4)</sup></td> </tr> </tbody> </table>	STANDARD	RATING	AAMA/WDMA/CSA 101/I.S.2/A440-11	CLASS LC <sup>(1)</sup> - PG50 <sup>(2)</sup> - SIZE TESTED 56 X 71.8 in. <sup>(3)</sup> DP+50/-50 <sup>(4)</sup>	AAMA/WDMA/CSA 101/I.S.2/A440-08
STANDARD	RATING					
AAMA/WDMA/CSA 101/I.S.2/A440-11	CLASS LC <sup>(1)</sup> - PG50 <sup>(2)</sup> - SIZE TESTED 56 X 71.8 in. <sup>(3)</sup> DP+50/-50 <sup>(4)</sup>					
AAMA/WDMA/CSA 101/I.S.2/A440-08	CLASS LC <sup>(1)</sup> - PG50 <sup>(2)</sup> - SIZE TESTED 56 X 71.8 in. <sup>(3)</sup> DP+50/-50 <sup>(4)</sup>					

- (1) - Performance Class
- (2) - Performance Grade
- (3) - Size Tested
- (4) - Design Pressure

In the example above, the performance class is LC, the performance grade (PG) is 50 pounds per square foot (psf) and the size tested is 56" x 71.8". What this means to the specifier is, based on the performance grade chart, the laboratory-tested air infiltration was less than 0.3 cfm/ft<sup>2</sup> (test pressure is always 1.57 psf and the allowable airflow is 0.3 cfm/ft<sup>2</sup>), the product tested successfully resisted a laboratory water penetration test at a test pressure of 7.5 psf, the product tested successfully withstood a laboratory positive test pressure of 75 psf and a laboratory negative test pressure of 75 psf and the product tested passed the laboratory requirements for operational force and forced-entry resistance. Based on this test, all products of the same design that are smaller than the tested size can be labeled with this product performance rating.

## IMPORTANT

Building codes prescribe design pressure based on a variety of criteria (i.e. windspeed zone, building height, building type, jobsite exposure, etc.). Design pressures derived from Performance Grade (PG) test requirements should be used to determine compliance to building code required design pressures. Structural test pressures, which are tested at 1.5 times the design pressure, should not be used for determining design pressure code compliance. In the example above, a PG 50 performance grade rating, which passes a 50 psf design pressure, should be used for determining code compliance, not the structural test pressure of 75 psf.

If you need further details about how Andersen® products perform to this standard, contact your Andersen supplier.

If you need further information about the AAMA/WDMA/CSA 101/I.S.2/A440-11 standard or the Hallmark Certification Program, please contact: WDMA, 330 N. Wabash Avenue Suite 2000, Chicago, IL 60611 Phone: 312-321-6802 Web: wdma.com

Where designated, Andersen products are tested, certified and labeled to the requirements of the Hallmark Certification Program. Actual performance may vary based on variations in manufacturing, shipping, installation, environmental conditions and conditions of use.

**Performance Grade, Air Infiltration and Sound Transmission Ratings – 400 Series Windows**

For current performance information, please visit [andersenwindows.com](http://andersenwindows.com).

Andersen® Product	AAMA/WDMA/CSA 101/I.S.2/A440 Performance Grade (PG)	+/- Corresponding Design Pressure (DP)	Air Infiltration CFM/FT <sup>2</sup>
<b>Casement Windows</b>			
Single Stationary (CXW16)	Class LC-PG50 Size Tested 35" x 71"	50/50	< 0.2
Single Venting (CXW16-155, CX16-155)	Class LC-PG40 Size Tested 35" x 71"	40/40	< 0.2
Single Venting (CXW15)	Class LC-PG45 Size Tested 71" x 60"	50/50	< 0.2
Single Venting (CW16 and smaller)	Class LC-PG50 Size Tested 56" x 71"	50/50	< 0.2
Single Venting (CXW145 and smaller)	Class LC-PG50 Size Tested 71" x 52"*	50/50	< 0.2
Single Venting (CX15 and smaller)	Class LC-PG50 Size Tested 62" x 59"*	50/50	< 0.2
Twin Stationary (CXW245, CX25, CW26 and smaller)	Class LC-PG50 Size Tested 56" x 71"*	50/50	< 0.2
Twin Venting (CXW25)	Class LC-PG45 Size Tested 71" x 60"	45/45	< 0.2
Twin Venting (CXW245 and smaller)	Class LC-PG50 Size Tested 71" x 52"	50/50	< 0.2
Twin Venting (CX25 and smaller)	Class LC-PG50 Size Tested 62" x 59"	50/50	< 0.2
Twin Venting (CW26 and smaller)	Class LC-PG50 Size Tested 56" x 71"	50/50	< 0.2
Triple Venting (CW35 and smaller)	Class LC-PG40 Size Tested 84" x 60"	40/40	< 0.2
Triple Venting (C35 and smaller)	Class LC-PG50 Size Tested 71" x 60"	50/50	< 0.2
Casement/Awning Picture Windows (P5060 and smaller)	Class LC-PG70 Size Tested 59" x 71"	70/70	< 0.2
Casement/Awning Transom Windows (CTR32410 and smaller)	Class LC-PG70 Size Tested 84" x 12"	70/70	< 0.2
<b>Casement Windows, PG Upgrade</b>			
Single Stationary (tempered glass, CXW16)	Class LC-PG70 Size Tested 35" x 71"	70/70	< 0.2
Single Venting (CXW145 and smaller)	Class LC-PG70 Size Tested 35" x 52"	70/70	< 0.2
Single Venting (CX16 and smaller)	Class LC-PG70 Size Tested 31" x 71"	70/70	< 0.2
Twin Venting (CW26 and smaller)	Class LC-PG70 Size Tested 56" x 71"	70/70	< 0.2
Triple Venting (C35 and smaller)	Class LC-PG70 Size Tested 71" x 59"	70/70	< 0.2
<b>Complementary Casement Windows</b>			
Casement Venting	Class LC-PG50 Size Tested 35" x 84"	50/50	< 0.2
Casement Stationary	Class LC-PG60 Size Tested 120" x 78"	60/60	< 0.2
French Casement Venting	Class LC-PG30 Size Tested 56" x 72"	30/30	< 0.2
<b>Awning Windows</b>			
Single Stationary (AXW61)	Class LC-PG50 Size Tested 35" x 71"	50/50	< 0.2
Single Venting (AXW51 and smaller)	Class LC-PG35 Size Tested 59" x 35"	35/35	< 0.2
Single Venting (AX61 and smaller)	Class LC-PG35 Size Tested 72" x 31"	35/35	< 0.2
Twin Venting (AXW231 and smaller)	Class LC-PG35 Size Tested 71" x 36"	35/35	< 0.2
Triple Venting (AX3251 and smaller)	Class LC-PG35 Size Tested 84" x 31"	35/35	< 0.2
Triple Venting (A313 and smaller)	Class LC-PG35 Size Tested 35" x 71"	35/35	< 0.2
Picture Venting (PA4060 and smaller)	Class LC-PG35 Size Tested 48" x 71"	35/35	< 0.2
<b>Awning Windows, PG Upgrade</b>			
Single Stationary (tempered glass, AXW61)	Class LC-PG70 Size Tested 35" x 71"	70/70	< 0.2
Single, Twin & Triple Venting (AX3251 and smaller)	Class LC-PG60 Size Tested 84" x 31"	60/60	< 0.2
Triple Venting (A313 and smaller)	Class LC-PG60 Size Tested 35" x 71"	60/60	< 0.2

For sound transmission ratings, see page 201.

Combination Design,  
Product Performance  
& Installation

\*Performance Grade (PG) ratings may vary from tested performance rating for larger or smaller units of a particular type. continued on next page  
 \*This data is accurate as of February 2019. Due to ongoing product changes, updated test results, or new industry standards, this data may change over time.  
 \*Where designated, Andersen products are certified and labeled to the requirements of the Hallmark Certification Program. Actual performance may vary based on variations in manufacturing, shipping, installation, environmental conditions and conditions of use.  
 \*Contact your Andersen supplier for more information.  
 \*Window size tested is an integral twin or triple window and qualifies the window listed under the same test.

# PRODUCT PERFORMANCE

## Performance Grade, Air Infiltration and Sound Transmission Ratings – 400 Series Windows *(continued)*

For current performance information, please visit [andersenwindows.com](http://andersenwindows.com).

Andersen® Product	AAMA/WDMA/CSA 101/1.S.2/A440 Performance Grade (PG)	+/- Corresponding Design Pressure (DP)	Air Infiltration CFM/FT <sup>2</sup>
<b>Woodwright® Full-Frame Windows</b>			
Double-Hung (3862 and smaller)	Class LC-PG30 Size Tested 45" x 76"	30/30	< 0.2
Double-Hung (cottage sash, 3862 and smaller)	Class R-20 Size Tested 45" x 76"	20/20	< 0.2
Arch Double-Hung (3862 and smaller)	Class LC-PG30 Size Tested 45" x 76"	30/30	< 0.2
Springline™ Single-Hung (3872 and smaller)	Class LC-PG30 Size Tested 45" x 86"	30/30	< 0.2
Picture (5662 and smaller)	Class LC-PG65 Size Tested 67" x 76"	65/65	< 0.2
Transom (6231 and smaller)	Class LC-PG70 Size Tested 75" x 39"	70/70	< 0.2
<b>Woodwright® Full-Frame Windows, PG Upgrade</b>			
Double-Hung (3052 and smaller)	Class LC-PG50 Size Tested 37" x 64"	50/50	< 0.2
Arch Double-Hung (3054)	Class LC-PG50 Size Tested 37" x 64"	50/50	< 0.2
Springline Single-Hung (3057)	Class LC-PG50 Size Tested 37" x 67"	50/50	< 0.2
<b>Woodwright® Insert Windows</b>			
Double-Hung (3862 and smaller)	Class R-PG25 Size Tested 45" x 77"	25/25	< 0.2
Double-Hung (cottage sash, 3862 and smaller)	Class R-PG20 Size Tested 45" x 68"	20/20	< 0.2
Picture (5662 and smaller)	Class LC-PG30 Size Tested 68" x 78"	30/30	< 0.2
Transom (6878 and smaller)	Class LC-PG30 Size Tested 68" x 78"	30/35	< 0.2
<b>Tilt-Wash Full-Frame Windows</b>			
Double-Hung (3862 and smaller)	Class LC-PG40 Size Tested 45" x 76"	40/40	< 0.2
Double-Hung (cottage sash, 3856 and smaller)	Class LC-PG40 Size Tested 45" x 68"	40/40	< 0.2
Double-Hung** (3876 and smaller)	Class LC-PG30 Size Tested 45" x 92"	30/35	< 0.2
Picture (5662 and smaller)	Class LC-PG50 Size Tested 67" x 76"	50/65	< 0.2
Transom (6231 and smaller)	Class LC-PG50 Size Tested 75" x 39"	50/50	< 0.2
<b>Tilt-Wash Windows, PG Upgrade</b>			
Double-Hung	Class LC-PG50 Size Tested 45" x 76"	50/65	< 0.2
Double-Hung (3456, 3856, 34510, 38510, 3462, 3862)	Class LC-PG50 Size Tested 45" x 76"	50/55	< 0.2
<b>Tilt-Wash Insert Windows</b>			
Double-Hung (double lock)	Class R-PG20 Size Tested 45" x 92"	20/20	< 0.2
Double-Hung (single lock)	Class R-PG20 Size Tested 35" x 92"	20/20	< 0.2
Double-Hung	Class R-PG20 Size Tested 45" x 76"	30/30	< 0.2
Gliding Windows (G65 and smaller)	Class LC-PG30 Size Tested 71" x 59"	30/30	< 0.2
<b>Specialty Windows</b>			
Arch (AFFW6080 and smaller)	Class LC-PG50 Size Tested 71" x 105"	50/50	< 0.2
Flexiframe® (12050 and smaller)	Class LC-PG50 Size Tested 144" x 60"	50/50	< 0.2
Springline™ (SP802 and smaller)	Class LC-PG50 Size Tested 96" x 72"	50/50	< 0.2
<b>Specialty Windows, PG Upgrade</b>			
Arch (tempered glass, AFFW6080 and smaller)	Class LC-PG70 Size Tested 71" x 105"	70/70	< 0.2
Flexiframe (tempered glass, 12050 and smaller)	Class LC-PG70 Size Tested 144" x 60"	70/70	< 0.2
Springline (tempered glass, SP802 and smaller)	Class LC-PG70 Size Tested 96" x 72"	70/70	< 0.2
Complementary Specialty Windows (direct-set, fixed)	Class LC-PG50 Size Tested 125" x 84"	50/50	< 0.2

For sound transmission ratings, see page 201.

\* "Performance Grade (PG)" ratings may vary from tested performance rating for larger or smaller units of a particular type.

\* This data is accurate as of February 2019. Due to ongoing product changes, updated test results, or new industry standards, this data may change over time.

\* Where designated, Andersen products are certified and labeled to the requirements of the Hallmark Certification Program. Actual performance may vary based on variations in manufacturing, shipping, installation, environmental conditions and conditions of use.

\* Contact your Andersen supplier for more information.

\*\* Window heights equal to or greater than 7'-4 9/16" (2250) and 7'-8 1/8" (2359) have interior and exterior brackets. Interior brackets, located on each side of the meeting rail, must be flipped up for proper product performance.

**Performance Grade, Air Infiltration and Sound Transmission Ratings – 400 Series Patio Doors**

For current performance information, please visit [andersenwindows.com](http://andersenwindows.com).

Andersen® Product	AAMA/WDMA/CSA 101/I.S.2/A440 Performance Grade (PG)	+/- Corresponding Design Pressure (DP)	Air Infiltration CFM/FT <sup>2</sup>
<b>Frenchwood® Gliding Patio Doors</b>			
Single Stationary	Class LC-PG40 Size Tested 50" x 95"	40/40	< 0.2
Two-Panel	Class LC-PG40 Size Tested 95" x 95"	40/40	< 0.2
Four-Panel (8')	Class LC-PG35 Size Tested 189" x 95"	35/35	< 0.2
Four-Panel (6'-11", 6'-8")	Class LC-PG25 Size Tested 189" x 82"	25/25	< 0.2
<b>Frenchwood® Hinged Inswing Patio Doors</b>			
Single Active	Class LC-PG40 Size Tested 38" x 95"	40/40	< 0.2
Two-Panel	Class LC-PG40 Size Tested 71" x 95"	40/40	< 0.2
Three-Panel	Class LC-PG40 Size Tested 107" x 95"	40/40	< 0.2
Frenchwood® Patio Door Sidelights	Class LC-PG65 Size Tested 18" x 95"	65/65	< 0.2
Frenchwood® Patio Door Transoms	Class LC-PG65 Size Tested 71" x 21"	65/65	< 0.2
<b>Complementary Springline™ &amp; Arch Hinged Inswing Patio Doors</b>			
Single Stationary	Class LC-PG45 Size Tested 37" x 95"	45/45	< 0.2
Single Active†	Class LC-PG45 Size Tested 37" x 95"	45/45	< 0.2
Two-Panel Stationary	Class LC-PG45 Size Tested 75" x 95"	45/45	< 0.2
Two-Panel Active†	Class LC-PG45 Size Tested 75" x 95"	45/45	< 0.2
<b>Complementary Springline &amp; Arch Hinged Outswing Patio Doors</b>			
Single Stationary	Class LC-PG45 Size Tested 37" x 95"	45/45	< 0.2
Single Active†	Class LC-PG45 Size Tested 37" x 95"	45/45	< 0.2
Two-Panel Stationary	Class LC-PG45 Size Tested 75" x 95"	45/45	< 0.2
Two-Panel Active†	Class LC-PG45 Size Tested 75" x 95"	45/45	< 0.2

\*"Performance Grade (PG)" ratings may vary from tested performance rating for larger or smaller units of a particular type.  
 \*This data is accurate as of February 2019. Due to ongoing product changes, updated test results, or new industry standards, this data may change over time.  
 \*Where designated, Andersen products are certified and labeled to the requirements of the Hallmark Certification Program. Actual performance may vary based on variations in manufacturing, shipping, installation, environmental conditions and conditions of use.  
 \*Contact your Andersen supplier for more information.  
 †Tested with standard multi-point hardware.

For sound transmission ratings, see page 201.

Combination Design,  
Product Performance  
& Installation

# PRODUCT PERFORMANCE

## Center of Glass Performance Data for products with Low-E4® SmartSun™ Glass

For current performance information, please visit [andersenwindows.com](http://andersenwindows.com).

Andersen® Product	VT <sup>1</sup>	SC <sup>2</sup>	SHGC <sup>3</sup>	RHG <sup>4</sup>	Fading		%RH @ Center <sup>7</sup>	IGST <sup>8</sup>
					Tuv <sup>5</sup>	Tdw <sup>6</sup>		
400 Series Casement, Awning & Tilt-Wash Double-Hung Full-Frame Windows	66%	0.32	0.28	66	5%	21%	61%	56°F
400 Series Gliding Window, Half Circle, Circle & Oval Windows	66%	0.31	0.27	66	5%	21%	61%	56°F
400 Series Casement/Awning Picture & Transoms, Woodwright® Double-Hung, Picture & Transom Full-Frame, Woodwright® Double-Hung, Picture & Transom Insert, Tilt-Wash Picture & Transom Full-Frame, Tilt-Wash Double-Hung, Picture & Transom Insert Windows	65%	0.31	0.27	65	5%	21%	61%	56°F
400 Series Elliptical Windows, Frenchwood® Hinged Inswing Patio Doors, Frenchwood® Patio Door Sidelights, Sidelight Transoms & Transoms	65%	0.31	0.27	66	5%	21%	61%	56°F
400 Series Frenchwood® Gliding Patio Doors	64%	0.32	0.27	66	5%	21%	61%	56°F
400 Series Flexiframe®, Arch & Springline® Windows	63%	0.31	0.27	65	4%	20%	61%	56°F
400 Series Complementary Springline & Arch Hinged Inswing Patio Doors	65%	0.31	0.27	207	5%	21%	61%	56°F

## Center of Glass Performance Data for products with Low-E4® Glass

For current performance information, please visit [andersenwindows.com](http://andersenwindows.com).

Andersen Product	VT <sup>1</sup>	SC <sup>2</sup>	SHGC <sup>3</sup>	RHG <sup>4</sup>	Fading		%RH @ Center <sup>7</sup>	IGST <sup>8</sup>
					Tuv <sup>5</sup>	Tdw <sup>6</sup>		
400 Series Casement, Awning & Tilt-Wash Double-Hung Full-Frame Windows	73%	0.48	0.42	100	17%	34%	61%	56°F
400 Series Gliding Window, Half Circle, Circle & Oval Windows	73%	0.48	0.42	99	17%	34%	61%	56°F
400 Series Casement/Awning Picture & Transoms, Woodwright® Double-Hung, Picture & Transom Full-Frame, Woodwright® Double-Hung, Picture & Transom Insert, Tilt-Wash Picture & Transom Full-Frame, Tilt-Wash Double-Hung, Picture & Transom Insert Windows	72%	0.47	0.41	98	16%	33%	61%	56°F
400 Series Elliptical Windows, Frenchwood Hinged Inswing Patio Doors, Frenchwood Patio Door Sidelights, Sidelight Transoms & Transoms	72%	0.48	0.41	98	16%	33%	61%	56°F
400 Series Frenchwood Gliding Patio Doors	71%	0.47	0.41	98	16%	33%	61%	56°F
400 Series Flexiframe, Arch & Springline Windows	70%	0.46	0.40	95	14%	31%	61%	56°F
400 Series Complementary Springline & Arch Hinged Inswing Patio Doors	72%	0.48	0.41	310	16%	33%	61%	56°F

## Center of Glass Performance Data for products with Low-E4® Sun Glass

For current performance information, please visit [andersenwindows.com](http://andersenwindows.com).

Andersen Product	VT <sup>1</sup>	SC <sup>2</sup>	SHGC <sup>3</sup>	RHG <sup>4</sup>	Fading		%RH @ Center <sup>7</sup>	IGST <sup>8</sup>
					Tuv <sup>5</sup>	Tdw <sup>6</sup>		
400 Series Casement, Awning & Tilt-Wash Double-Hung Full-Frame Windows	40%	0.30	0.26	62	17%	25%	61%	56°F
400 Series Gliding Window, Half Circle, Circle & Oval Windows	40%	0.29	0.26	62	17%	25%	59%	55°F
400 Series Casement/Awning Picture & Transoms, Woodwright® Double-Hung, Picture & Transom Full-Frame, Woodwright® Double-Hung, Picture & Transom Insert, Tilt-Wash Picture & Transom Full-Frame, Tilt-Wash Double-Hung, Picture & Transom Insert Windows	40%	0.29	0.25	61	16%	24%	59%	55°F
400 Series Elliptical Windows, Frenchwood Hinged Inswing Patio Doors, Frenchwood Patio Door Sidelights, Sidelight Transoms & Transoms	40%	0.29	0.25	61	16%	24%	59%	55°F
400 Series Frenchwood Gliding Patio Doors	39%	0.29	0.25	61	15%	23%	61%	56°F
400 Series Flexiframe, Arch & Springline Windows	37%	0.28	0.24	59	13%	22%	61%	56°F
400 Series Complementary Springline & Arch Hinged Inswing Patio Doors	40%	0.29	0.25	193	16%	24%	59%	55°F

\* "Low-E4"; "Low-E4 SmartSun" and "Low-E4 Sun" are Andersen trademarks for "Low-E" glass.

\* Based on NFRC testing/simulation conditions using Windows v7.4.6.0 and NFRC validated spectral data. 0°F outside temperature, 70°F inside temperature and a 15 mph wind.

1) Visible Transmittance (VT) measures how much light comes through the glass. The higher the value, from 0 to 1, the more daylight the glass lets in. Visible Transmittance is measured over the 380 to 760 nanometer portion of the solar spectrum.

2) Shading Coefficient (SC) defines the amount of heat gain through the glass compared to a single light of clear 1/8" (3) glass.

3) Solar Heat Gain Coefficient (SHGC) defines the fraction of solar radiation admitted through the glass both directly transmitted and absorbed and subsequently released inward. The lower the value, the less heat is transmitted through the glass.

4) Relative Heat Gain (RHG) is the amount of heat gain through a glazing incorporating U-Factor and Solar Heat Gain Coefficient.

5) Transmission Ultra-Violet Energy (Tuv). The transmission of short-wave energy in the 300-380 nanometer portion of the solar spectrum. The energy can cause fabric fading.

6) Transmission Damage Function (Tdw). The transmission of UV and visible light energy in the 300-600 nanometer portion of the solar spectrum. The value includes both the UV and visible light energy that can cause fabric fading.

This rating has also been referred to as the Krochmann Damage Function. This rating better predicts fading potential than UV transmission alone. The lower the Damage Function rating, the less transmission of short-wave energy through the glass that can potentially cause fabric fading. Fabric type is also a key component of fading potential.

7) Percent relative humidity before condensation occurs at the center of glass, taken using center of glass temperature.

8) Inside glass surface temperatures are taken at the center of glass.

\* This data is accurate as of February 2019. Due to ongoing product changes, updated test results, or new industry standards, this data may change over time. Contact your Andersen supplier for current performance information or upgrade options.

\* Contact your Andersen supplier or visit [andersenwindows.com/nfrc](http://andersenwindows.com/nfrc) for total unit performance data on windows and patio doors (including units with patterned glass, tempered glass and glass with capillary breather tubes).

**Sound Transmission Ratings for 400 Series Windows & Patio Doors**

For current performance information, please visit [andersenwindows.com](http://andersenwindows.com).

Andersen® Product	Test Size	Sound Transmission Class (STC)	Outdoor/Indoor Transmission Class (OITC)
<b>Casement &amp; Awning Windows</b>			
Casement	36" x 72"	26	22
Awning	30" x 60"	26	21
Casement/Awning Picture	60" x 72"	29	25
<b>Woodwright® Double-Hung Full-Frame Windows</b>			
Double-Hung	46" x 77"	28	23
Picture	48" x 48"	28	23
Transom	40" x 46"	28	22
<b>Woodwright® Double-Hung Insert Windows</b>			
Double-Hung	20" x 60"	26	21
Picture	53" x 78"	30	26
Transom	53" x 78"	30	26
<b>Tilt-Wash Double-Hung Full-Frame Windows</b>			
Double-Hung	46" x 78"	26	23
Picture	68" x 77"	30	25
Transom	-	-	-
<b>Tilt-Wash Double-Hung Insert Windows</b>			
Double-Hung	32" x 76"	27	24
Picture	-	-	-
Transom	-	-	-
<b>Gliding Windows</b>	72" x 60"	26	22
<b>Specialty Windows</b>	72" x 60"	30	25
<b>Complementary Specialty Windows</b>	72" x 60"	30	25
<b>Frenchwood® Gliding Patio Doors</b>			
Single Stationary	50" x 80"	31	26
Two-Panel	72" x 80"	31	26
Four-Panel	-	-	-
<b>Frenchwood® Hinged Inswing Patio Doors</b>			
Single Active	36" x 80"	32	27
Two-Panel	72" x 80"	31	26
Three-Panel	-	-	-
<b>Frenchwood® Patio Door Sidelights &amp; Transoms</b>			
Sidelight	18" x 82"	32	26
Transom	72" x 22"	29	25
<b>Complementary Springline™ &amp; Arch Hinged Inswing Patio Doors</b>			
Single Active	38" x 90"	30	25
Two-Panel	75" x 90"	30	25
<b>Complementary Springline™ &amp; Arch Hinged Outswing Patio Doors</b>			
Single-Panel	38" x 90"	31	25
Two-Panel	75" x 90"	31	25

- \*Sound Transmission Class (STC) and "Outdoor/Indoor Transmission Class (OITC)" ratings are for individual units based on independent tests and represent entire unit.
- \*This data is accurate as of February 2019. Due to ongoing product changes, updated test results or new industry standards, this data may change over time.
- \*Contact your Andersen supplier for more information.

**Andersen® NFRC Certified Total Unit Performance**

For current performance information, please visit [andersenwindows.com](http://andersenwindows.com).

Andersen® Product	High-Performance Dual-Pane Glass Type	U-Factor <sup>1</sup>	SHGC <sup>2</sup>	VT <sup>3</sup>	
<b>400 Series Casement Windows</b> AND-N-1	Low-E4*	Without Grilles	0.29	0.31	0.54
		Simulated Divided Light Grilles	0.29	0.29	0.49
		Finelight™ Grilles	0.30	0.29	0.49
	Low-E4 w/HeatLock*	Without Grilles	0.25	0.31	0.52
		Simulated Divided Light Grilles	0.25	0.28	0.47
		Finelight Grilles	0.26	0.28	0.47
	Low-E4 Sun	Without Grilles	0.29	0.20	0.30
		Simulated Divided Light Grilles	0.29	0.18	0.27
		Finelight Grilles	0.30	0.18	0.27
	Low-E4 SmartSun™	Without Grilles	0.28	0.21	0.48
		Simulated Divided Light Grilles	0.28	0.19	0.44
		Finelight Grilles	0.29	0.19	0.44
Low-E4 SmartSun w/HeatLock	Without Grilles	0.24	0.21	0.47	
	Simulated Divided Light Grilles	0.24	0.19	0.43	
	Finelight Grilles	0.25	0.19	0.43	
<b>400 Series Complementary Casement Windows</b> AND-N-107	Low-E4*	Without Grilles	0.31	0.28	0.47
		Simulated Divided Light Grilles	0.31	0.25	0.42
		Finelight™ Grilles	0.31	0.25	0.42
	Low-E4 w/HeatLock*	Without Grilles	0.27	0.27	0.46
		Simulated Divided Light Grilles	0.27	0.25	0.41
		Finelight Grilles	0.27	0.25	0.41
	Low-E4 Sun	Without Grilles	0.31	0.17	0.26
		Simulated Divided Light Grilles	0.31	0.16	0.23
		Finelight Grilles	0.31	0.16	0.23
	Low-E4 SmartSun™	Without Grilles	0.30	0.18	0.42
		Simulated Divided Light Grilles	0.30	0.17	0.38
		Finelight Grilles	0.30	0.17	0.38
Low-E4 SmartSun w/HeatLock	Without Grilles	0.27	0.18	0.41	
	Simulated Divided Light Grilles	0.27	0.17	0.37	
	Finelight Grilles	0.27	0.17	0.37	
<b>400 Series Awning Windows</b> AND-N-2	Low-E4*	Without Grilles	0.29	0.31	0.53
		Simulated Divided Light Grilles	0.29	0.28	0.48
		Finelight™ Grilles	0.29	0.28	0.48
	Low-E4 w/HeatLock*	Without Grilles	0.25	0.30	0.51
		Simulated Divided Light Grilles	0.25	0.28	0.47
		Finelight Grilles	0.26	0.28	0.47
	Low-E4 Sun	Without Grilles	0.29	0.19	0.29
		Simulated Divided Light Grilles	0.29	0.18	0.27
		Finelight Grilles	0.30	0.18	0.27
	Low-E4 SmartSun™	Without Grilles	0.28	0.21	0.47
		Simulated Divided Light Grilles	0.28	0.19	0.43
		Finelight Grilles	0.29	0.19	0.43
Low-E4 SmartSun w/HeatLock	Without Grilles	0.25	0.20	0.46	
	Simulated Divided Light Grilles	0.25	0.19	0.42	
	Finelight Grilles	0.25	0.19	0.42	

continued on next page

- \*"Low-E4" SmartSun™, "Low-E4", "Low-E4" Sun and HeatLock are Andersen trademarks for "Low-E" glass.
- 1) U-Factor defines the amount of heat loss through the total unit in BTU/hr/ft<sup>2</sup>·°F. The lower the value, the less heat is lost through the entire product. Window values represent non-tempered glass. Use of tempered glass can increase U-Factor ratings. See [andersenwindows.com/nfrc](http://andersenwindows.com/nfrc) for specific performance values. Door values represent tempered glass.
- 2) Solar Heat Gain Coefficient (SHGC) defines the fraction of solar radiation admitted through the glass both directly transmitted and absorbed and subsequently released inward. The lower the value, the less heat is transmitted through the product.
- 3) Visible Transmittance (VT) measures how much light comes through a product (glass and frame). The higher the value, from 0 to 1, the more daylight the product lets in over the product's total unit area. Visible Light Transmittance is measured over the 380 to 760 nanometer portion of the solar spectrum.
- \*NFRC ratings are based on modeling by a third-party agency as validated by an independent test lab in compliance with NFRC program and procedural requirements.
- \*This data is accurate as of February 2019. Due to ongoing product changes, updated test results, or new industry standards or requirements, this data may change over time. Ratings are for sizes specified by NFRC for testing and certification. Ratings may vary depending on use of tempered glass, different grille options, glass with capillary breather tubes for high altitudes, etc.
- "Low-E4", "Low-E4 SmartSun™" and "Low-E4 Sun"

Combination Design, Product Performance & Installation

# PRODUCT PERFORMANCE

## Andersen® NFRC Certified Total Unit Performance (continued)

For current performance information, please visit [andersenwindows.com](http://andersenwindows.com).

Andersen® Product	High-Performance Dual-Pane Glass Type	U-Factor <sup>1</sup>	SHGC <sup>2</sup>	VT <sup>3</sup>	
400 Series Casement/Awning Picture & Transom Windows AND-N-54	Low-E4*	Without Grilles	0.27	0.34	0.59
		Simulated Divided Light Grilles	0.27	0.31	0.53
		Finelight™ Grilles	0.27	0.31	0.53
		Full Divided Light Grilles	0.28	0.31	0.53
	Low-E4 w/HeatLock*	Without Grilles	0.22	0.33	0.58
		Simulated Divided Light Grilles	0.22	0.30	0.52
		Finelight™ Grilles	0.22	0.30	0.52
		Full Divided Light Grilles	0.24	0.30	0.52
	Low-E4 Sun	Without Grilles	0.27	0.21	0.32
		Simulated Divided Light Grilles	0.27	0.19	0.29
		Finelight™ Grilles	0.27	0.19	0.29
	Low-E4 SmartSun™	Without Grilles	0.26	0.23	0.53
		Simulated Divided Light Grilles	0.26	0.21	0.48
		Finelight™ Grilles	0.26	0.21	0.48
	Low-E4 SmartSun w/HeatLock	Without Grilles	0.22	0.22	0.52
		Simulated Divided Light Grilles	0.22	0.20	0.47
Finelight™ Grilles		0.22	0.20	0.47	
400 Series Woodwright® Double-Hung Full-Frame Windows AND-N-66	Low-E4*	Without Grilles	0.30	0.30	0.52
		Simulated Divided Light Grilles	0.30	0.27	0.46
		Finelight™ Grilles	0.31	0.27	0.46
		Full Divided Light Grilles	0.31	0.27	0.46
	Low-E4 w/HeatLock*	Without Grilles	0.26	0.30	0.51
		Simulated Divided Light Grilles	0.26	0.27	0.45
		Finelight™ Grilles	0.27	0.27	0.45
		Full Divided Light Grilles	0.28	0.27	0.45
	Low-E4 Sun	Without Grilles	0.30	0.19	0.28
		Simulated Divided Light Grilles	0.30	0.17	0.25
		Finelight™ Grilles	0.31	0.17	0.25
	Low-E4 SmartSun™	Without Grilles	0.29	0.21	0.47
		Simulated Divided Light Grilles	0.29	0.19	0.42
		Finelight™ Grilles	0.30	0.19	0.42
	Low-E4 SmartSun w/HeatLock	Without Grilles	0.26	0.20	0.46
		Simulated Divided Light Grilles	0.26	0.18	0.41
Finelight™ Grilles		0.27	0.18	0.41	
400 Series Woodwright® Picture Full-Frame Windows AND-N-67	Low-E4*	Without Grilles	0.28	0.31	0.53
		Simulated Divided Light Grilles	0.28	0.28	0.48
		Finelight™ Grilles	0.29	0.28	0.48
		Full Divided Light Grilles	0.29	0.29	0.48
	Low-E4 w/HeatLock*	Without Grilles	0.24	0.30	0.52
		Simulated Divided Light Grilles	0.24	0.27	0.47
		Finelight™ Grilles	0.25	0.27	0.47
		Full Divided Light Grilles	0.26	0.27	0.47
	Low-E4 Sun	Without Grilles	0.28	0.20	0.29
		Simulated Divided Light Grilles	0.28	0.18	0.26
		Finelight™ Grilles	0.29	0.17	0.26
	Low-E4 SmartSun™	Without Grilles	0.27	0.21	0.48
		Simulated Divided Light Grilles	0.27	0.19	0.43
		Finelight™ Grilles	0.28	0.19	0.43
	Low-E4 SmartSun w/HeatLock	Without Grilles	0.23	0.21	0.47
		Simulated Divided Light Grilles	0.23	0.19	0.42
Finelight™ Grilles		0.24	0.19	0.42	
400 Series Woodwright® Transom Full-Frame Windows AND-N-68	Low-E4*	Without Grilles	0.28	0.33	0.57
		Simulated Divided Light Grilles	0.28	0.30	0.51
		Finelight™ Grilles	0.28	0.30	0.51
		Full Divided Light Grilles	0.29	0.30	0.51
	Low-E4 w/HeatLock*	Without Grilles	0.23	0.32	0.56
		Simulated Divided Light Grilles	0.23	0.29	0.50
		Finelight™ Grilles	0.23	0.29	0.50
		Full Divided Light Grilles	0.25	0.29	0.50
	Low-E4 Sun	Without Grilles	0.28	0.20	0.31
		Simulated Divided Light Grilles	0.28	0.18	0.28
		Finelight™ Grilles	0.28	0.18	0.28
	Low-E4 SmartSun™	Without Grilles	0.27	0.22	0.51
		Simulated Divided Light Grilles	0.27	0.20	0.46
		Finelight™ Grilles	0.27	0.20	0.46
	Low-E4 SmartSun w/HeatLock	Without Grilles	0.23	0.22	0.50
		Simulated Divided Light Grilles	0.23	0.20	0.45
Finelight™ Grilles		0.23	0.20	0.45	

Andersen® Product	High-Performance Dual-Pane Glass Type	U-Factor <sup>1</sup>	SHGC <sup>2</sup>	VT <sup>3</sup>	
400 Series Woodwright® Double-Hung Insert Windows AND-N-74	Low-E4*	Without Grilles	0.30	0.31	0.53
		Simulated Divided Light Grilles	0.30	0.28	0.47
		Finelight™ Grilles	0.31	0.28	0.47
		Full Divided Light Grilles	0.31	0.28	0.47
	Low-E4 w/HeatLock*	Without Grilles	0.27	0.30	0.52
		Simulated Divided Light Grilles	0.27	0.27	0.46
		Finelight™ Grilles	0.27	0.27	0.46
		Full Divided Light Grilles	0.28	0.27	0.46
	Low-E4 Sun	Without Grilles	0.31	0.19	0.29
		Simulated Divided Light Grilles	0.31	0.17	0.26
		Finelight™ Grilles	0.32	0.17	0.26
	Low-E4 SmartSun™	Without Grilles	0.30	0.21	0.48
		Simulated Divided Light Grilles	0.30	0.19	0.42
		Finelight™ Grilles	0.31	0.19	0.42
	Low-E4 SmartSun w/HeatLock	Without Grilles	0.26	0.20	0.46
		Simulated Divided Light Grilles	0.26	0.18	0.41
Finelight™ Grilles		0.27	0.18	0.41	
400 Series Woodwright® Picture Insert Windows AND-N-77	Low-E4*	Without Grilles	0.29	0.32	0.54
		Simulated Divided Light Grilles	0.29	0.29	0.48
		Finelight™ Grilles	0.30	0.28	0.48
		Full Divided Light Grilles	0.30	0.29	0.48
	Low-E4 w/HeatLock*	Without Grilles	0.25	0.30	0.52
		Simulated Divided Light Grilles	-	-	-
		Finelight™ Grilles	0.26	0.27	0.47
		Full Divided Light Grilles	0.27	0.27	0.47
	Low-E4 Sun	Without Grilles	0.29	0.20	0.29
		Simulated Divided Light Grilles	0.29	0.18	0.26
		Finelight™ Grilles	0.30	0.18	0.26
	Low-E4 SmartSun™	Without Grilles	0.28	0.22	0.48
		Simulated Divided Light Grilles	0.28	0.20	0.43
		Finelight™ Grilles	0.29	0.20	0.43
	Low-E4 SmartSun w/HeatLock	Without Grilles	0.24	0.21	0.47
		Simulated Divided Light Grilles	-	-	-
Finelight™ Grilles		0.25	0.19	0.42	
400 Series Woodwright® Transom Insert Windows AND-N-78	Low-E4*	Without Grilles	0.29	0.33	0.56
		Simulated Divided Light Grilles	0.29	0.30	0.50
		Finelight™ Grilles	0.29	0.30	0.50
		Full Divided Light Grilles	0.30	0.30	0.50
	Low-E4 w/HeatLock*	Without Grilles	0.24	0.32	0.55
		Simulated Divided Light Grilles	-	-	-
		Finelight™ Grilles	0.24	0.29	0.49
		Full Divided Light Grilles	0.26	0.29	0.49
	Low-E4 Sun	Without Grilles	0.29	0.20	0.31
		Simulated Divided Light Grilles	0.29	0.18	0.27
		Finelight™ Grilles	0.29	0.18	0.27
	Low-E4 SmartSun™	Without Grilles	0.31	0.18	0.27
		Simulated Divided Light Grilles	0.28	0.22	0.50
		Finelight™ Grilles	0.28	0.20	0.45
	Low-E4 SmartSun w/HeatLock	Without Grilles	0.28	0.20	0.45
		Simulated Divided Light Grilles	0.30	0.20	0.45
Finelight™ Grilles		0.30	0.20	0.45	
Low-E4 SmartSun w/HeatLock	Without Grilles	0.24	0.21	0.49	
	Simulated Divided Light Grilles	-	-	-	
	Finelight™ Grilles	0.24	0.19	0.44	
Low-E4 SmartSun w/HeatLock	Without Grilles	0.26	0.19	0.44	
	Simulated Divided Light Grilles	0.26	0.19	0.44	
	Finelight™ Grilles	0.26	0.19	0.44	

continued on next page

\* "Low-E4" SmartSun," "Low-E4," "Low-E4" Sun" and HeatLock" are Andersen trademarks for "Low-E" glass.  
 1) U-Factor defines the amount of heat loss through the total unit in BTU/hr/ft<sup>2</sup>·°F. The lower the value, the less heat is lost through the entire product. Window values represent non-tempered glass. Use of tempered glass can increase U-Factor ratings. See [andersenwindows.com/nfrc](http://andersenwindows.com/nfrc) for specific performance values. Door values represent tempered glass. 2) Solar Heat Gain Coefficient (SHGC) defines the fraction of solar radiation admitted through the glass both directly transmitted and absorbed and subsequently released inward. The lower the value, the less heat is transmitted through the product. 3) Visible Transmittance (VT) measures how much light comes through a product (glass and frame). The higher the value, from 0 to 1, the more daylight the product lets in over the product's total unit area. Visible Light Transmittance is measured over the 380 to 760 nanometer portion of the solar spectrum.  
 • NFRC ratings are based on modeling by a third-party agency as validated by an independent test lab in compliance with NFRC program and procedural requirements.  
 • This data is accurate as of February 2019. Due to ongoing product changes, updated test results, or new industry standards or requirements, this data may change over time. Ratings are for sizes specified by NFRC for testing and certification. Ratings may vary depending on use of tempered glass, different grille options, glass with capillary breather tubes for high altitudes, etc.

**Andersen® NFRC Certified Total Unit Performance** (continued)

For current performance information, please visit [andersenwindows.com](http://andersenwindows.com).

Andersen® Product	High-Performance Dual-Pane Glass Type	U-Factor <sup>1</sup>	SHGC <sup>2</sup>	VT <sup>3</sup>	
<b>400 Series Woodwright® Springline™ Single-Hung, Arch Double-Hung Full-Frame Windows</b> AND-N-111	Low-E4*	Without Grilles	0.28	0.30	0.52
		Simulated Divided Light Grilles	0.28	0.27	0.46
		Finelight™ Grilles	0.29	0.27	0.46
		Full Divided Light Grilles	0.29	0.27	0.46
	Low-E4 w/HeatLock®	Without Grilles	0.24	0.30	0.51
		Simulated Divided Light Grilles	0.25	0.27	0.45
		Finelight Grilles	0.25	0.27	0.45
		Full Divided Light Grilles	0.26	0.27	0.45
	Low-E4 Sun	Without Grilles	0.28	0.19	0.29
		Simulated Divided Light Grilles	0.28	0.17	0.26
		Finelight Grilles	0.29	0.17	0.26
		Full Divided Light Grilles	0.29	0.17	0.26
Low-E4 SmartSun™	Without Grilles	0.28	0.20	0.47	
	Simulated Divided Light Grilles	0.27	0.18	0.42	
	Finelight Grilles	0.28	0.18	0.42	
	Full Divided Light Grilles	0.29	0.18	0.42	
Low-E4 SmartSun w/HeatLock	Without Grilles	0.24	0.20	0.46	
	Simulated Divided Light Grilles	0.24	0.18	0.41	
	Finelight Grilles	0.25	0.18	0.41	
	Full Divided Light Grilles	0.26	0.18	0.41	
<b>400 Series Tilt-Wash Double-Hung Full-Frame Windows</b> AND-N-24	Low-E4*	Without Grilles	0.30	0.31	0.53
		Simulated Divided Light Grilles	0.30	0.28	0.47
		Finelight™ Grilles	0.30	0.28	0.47
		Full Divided Light Grilles	0.31	0.28	0.42
	Low-E4 w/HeatLock®	Without Grilles	0.27	0.30	0.52
		Simulated Divided Light Grilles	0.27	0.27	0.46
		Finelight Grilles	0.27	0.27	0.46
		Full Divided Light Grilles	0.28	0.27	0.46
	Low-E4 Sun	Without Grilles	0.31	0.19	0.29
		Simulated Divided Light Grilles	0.30	0.17	0.26
		Finelight Grilles	0.30	0.17	0.26
		Full Divided Light Grilles	0.31	0.17	0.26
Low-E4 SmartSun™	Without Grilles	0.30	0.21	0.48	
	Simulated Divided Light Grilles	0.29	0.19	0.42	
	Finelight Grilles	0.29	0.19	0.42	
	Full Divided Light Grilles	0.31	0.19	0.42	
Low-E4 SmartSun w/HeatLock	Without Grilles	0.26	0.20	0.46	
	Simulated Divided Light Grilles	0.26	0.18	0.41	
	Finelight Grilles	0.27	0.18	0.41	
	Full Divided Light Grilles	0.28	0.18	0.41	
<b>400 Series Tilt-Wash Picture Full-Frame Windows</b> AND-N-27	Low-E4*	Without Grilles	0.29	0.33	0.56
		Simulated Divided Light Grilles	0.29	0.30	0.50
		Finelight™ Grilles	0.29	0.30	0.50
		Full Divided Light Grilles	0.31	0.30	0.50
	Low-E4 w/HeatLock®	Without Grilles	0.25	0.32	0.55
		Simulated Divided Light Grilles	0.25	0.29	0.49
		Finelight Grilles	0.25	0.29	0.49
		Full Divided Light Grilles	0.27	0.29	0.49
	Low-E4 Sun	Without Grilles	0.30	0.20	0.31
		Simulated Divided Light Grilles	0.30	0.18	0.27
		Finelight Grilles	0.30	0.18	0.27
		Full Divided Light Grilles	0.31	0.18	0.27
Low-E4 SmartSun™	Without Grilles	0.29	0.22	0.51	
	Simulated Divided Light Grilles	0.29	0.20	0.45	
	Finelight Grilles	0.29	0.20	0.45	
	Full Divided Light Grilles	0.30	0.20	0.45	
Low-E4 SmartSun w/HeatLock	Without Grilles	0.25	0.21	0.50	
	Simulated Divided Light Grilles	0.25	0.19	0.44	
	Finelight Grilles	0.25	0.19	0.44	
	Full Divided Light Grilles	0.27	0.19	0.44	
<b>400 Series Tilt-Wash Transom Full-Frame Windows</b> AND-N-76	Low-E4*	Without Grilles	0.27	0.32	0.55
		Simulated Divided Light Grilles	0.27	0.29	0.49
		Finelight™ Grilles	0.27	0.29	0.49
		Full Divided Light Grilles	0.28	0.29	0.49
	Low-E4 w/HeatLock®	Without Grilles	0.23	0.31	0.54
		Simulated Divided Light Grilles	0.23	0.28	0.48
		Finelight Grilles	0.23	0.28	0.48
		Full Divided Light Grilles	0.25	0.28	0.48
	Low-E4 Sun	Without Grilles	0.27	0.19	0.31
		Simulated Divided Light Grilles	0.27	0.18	0.27
		Finelight Grilles	0.27	0.18	0.27
		Full Divided Light Grilles	0.29	0.18	0.27
Low-E4 SmartSun™	Without Grilles	0.26	0.21	0.49	
	Simulated Divided Light Grilles	0.26	0.19	0.44	
	Finelight Grilles	0.26	0.19	0.44	
	Full Divided Light Grilles	0.28	0.19	0.44	
Low-E4 SmartSun w/HeatLock	Without Grilles	0.22	0.21	0.48	
	Simulated Divided Light Grilles	0.22	0.19	0.43	
	Finelight Grilles	0.22	0.19	0.43	
	Full Divided Light Grilles	0.25	0.19	0.43	

Andersen® Product	High-Performance Dual-Pane Glass Type	U-Factor <sup>1</sup>	SHGC <sup>2</sup>	VT <sup>3</sup>	
<b>Narroline® Conversion Kit</b> AND-N-101	Low-E4*	Without Grilles	0.30	0.31	0.53
		Simulated Divided Light Grilles	0.30	0.28	0.47
		Finelight™ Grilles	0.31	0.28	0.47
		Full Divided Light Grilles	0.31	0.28	0.47
	Low-E4 w/HeatLock®	Without Grilles	0.26	0.30	0.52
		Simulated Divided Light Grilles	0.26	0.27	0.46
		Finelight Grilles	0.26	0.27	0.46
		Full Divided Light Grilles	0.26	0.27	0.46
	Low-E4 Sun	Without Grilles	0.31	0.19	0.30
		Simulated Divided Light Grilles	0.31	0.17	0.26
		Finelight Grilles	0.32	0.17	0.26
		Full Divided Light Grilles	0.32	0.17	0.26
Low-E4 SmartSun™	Without Grilles	0.30	0.21	0.48	
	Simulated Divided Light Grilles	0.30	0.19	0.43	
	Finelight Grilles	0.31	0.19	0.43	
	Full Divided Light Grilles	0.31	0.19	0.43	
Low-E4 SmartSun w/HeatLock	Without Grilles	0.26	0.20	0.47	
	Simulated Divided Light Grilles	0.26	0.18	0.42	
	Finelight Grilles	0.26	0.18	0.42	
	Full Divided Light Grilles	0.26	0.18	0.42	
<b>400 Series Tilt-Wash Double-Hung Insert Windows</b> AND-N-132	Low-E4*	Without Grilles	0.31	0.31	0.54
		Simulated Divided Light Grilles	0.31	0.28	0.48
		Finelight™ Grilles	0.32	0.28	0.48
		Full Divided Light Grilles	0.32	0.28	0.48
	Low-E4 w/HeatLock®	Without Grilles	0.27	0.31	0.52
		Simulated Divided Light Grilles	0.27	0.28	0.46
		Finelight Grilles	0.28	0.28	0.46
		Full Divided Light Grilles	0.29	0.28	0.46
	Low-E4 Sun	Without Grilles	0.31	0.19	0.30
		Simulated Divided Light Grilles	0.31	0.18	0.26
		Finelight Grilles	0.33	0.18	0.26
		Full Divided Light Grilles	0.32	0.18	0.26
Low-E4 SmartSun™	Without Grilles	0.30	0.21	0.48	
	Simulated Divided Light Grilles	0.30	0.19	0.43	
	Finelight Grilles	0.32	0.19	0.43	
	Full Divided Light Grilles	0.31	0.19	0.43	
Low-E4 SmartSun w/HeatLock	Without Grilles	0.27	0.20	0.47	
	Simulated Divided Light Grilles	0.27	0.19	0.42	
	Finelight Grilles	0.27	0.19	0.42	
	Full Divided Light Grilles	0.28	0.19	0.42	
<b>400 Series Tilt-Wash Picture Insert Windows</b> AND-N-133	Low-E4*	Without Grilles	0.29	0.32	0.54
		Simulated Divided Light Grilles	0.29	0.29	0.48
		Finelight™ Grilles	0.30	0.28	0.48
		Full Divided Light Grilles	0.30	0.29	0.48
	Low-E4 w/HeatLock®	Without Grilles	0.25	0.30	0.52
		Simulated Divided Light Grilles	-	-	-
		Finelight Grilles	0.26	0.27	0.47
		Full Divided Light Grilles	0.27	0.27	0.47
	Low-E4 Sun	Without Grilles	0.29	0.20	0.29
		Simulated Divided Light Grilles	0.29	0.18	0.26
		Finelight Grilles	0.30	0.18	0.26
		Full Divided Light Grilles	0.31	0.18	0.26
Low-E4 SmartSun™	Without Grilles	0.28	0.22	0.48	
	Simulated Divided Light Grilles	0.28	0.20	0.43	
	Finelight Grilles	0.29	0.20	0.43	
	Full Divided Light Grilles	0.30	0.19	0.43	
Low-E4 SmartSun w/HeatLock	Without Grilles	0.24	0.21	0.47	
	Simulated Divided Light Grilles	-	-	-	
	Finelight Grilles	0.25	0.19	0.42	
	Full Divided Light Grilles	0.26	0.19	0.42	

continued on next page

\* "Low-E4" SmartSun," "Low-E4," "Low-E4" Sun" and HeatLock" are Andersen trademarks for "Low-E" glass.  
 1) U-Factor defines the amount of heat loss through the total unit in BTU/hr/ft<sup>2</sup>·°F. The lower the value, the less heat is lost through the entire product. Window values represent non-tempered glass. Use of tempered glass can increase U-Factor ratings. See [andersenwindows.com/nfrc](http://andersenwindows.com/nfrc) for specific performance values. Door values represent tempered glass. 2) Solar Heat Gain Coefficient (SHGC) defines the fraction of solar radiation admitted through the glass both directly transmitted and absorbed and subsequently released inward. The lower the value, the less heat is transmitted through the product. 3) Visible Transmittance (VT) measures how much light comes through a product (glass and frame). The higher the value, from 0 to 1, the more daylight the product lets in over the product's total unit area. Visible Light Transmittance is measured over the 380 to 760 nanometer portion of the solar spectrum.  
 • NFRC ratings are based on modeling by a third-party agency as validated by an independent test lab in compliance with NFRC program and procedural requirements.  
 • This data is accurate as of February 2019. Due to ongoing product changes, updated test results, or new industry standards or requirements, this data may change over time. Ratings are for sizes specified by NFRC for testing and certification. Ratings may vary depending on use of tempered glass, different grille options, glass with capillary breather tubes for high altitudes, etc.

Combination Design,  
Product Performance  
& Installation

# PRODUCT PERFORMANCE

## Andersen® NFRC Certified Total Unit Performance (continued)

For current performance information, please visit [andersenwindows.com](http://andersenwindows.com).

Andersen® Product	High-Performance Dual-Pane Glass Type	U-Factor <sup>1</sup>	SHGC <sup>2</sup>	VT <sup>3</sup>	
<b>400 Series Tilt-Wash Transom Insert Windows</b> AND-N-134	Low-E4*	Without Grilles	0.29	0.33	0.56
		Simulated Divided Light Grilles	0.29	0.30	0.50
		Finelight™ Grilles	0.29	0.30	0.50
		Full Divided Light Grilles	0.30	0.30	0.50
	Low-E4 w/HeatLock®	Without Grilles	0.24	0.32	0.55
		Simulated Divided Light Grilles	-	-	-
		Finelight Grilles	0.24	0.29	0.49
		Full Divided Light Grilles	0.27	0.29	0.49
	Low-E4 Sun	Without Grilles	0.29	0.20	0.31
		Simulated Divided Light Grilles	0.29	0.18	0.27
		Finelight Grilles	0.29	0.18	0.27
		Full Divided Light Grilles	0.31	0.18	0.27
	Low-E4 SmartSun™	Without Grilles	0.28	0.22	0.50
		Simulated Divided Light Grilles	0.28	0.20	0.45
		Finelight Grilles	0.28	0.20	0.45
		Full Divided Light Grilles	0.30	0.20	0.45
Low-E4 SmartSun w/HeatLock	Without Grilles	0.24	0.21	0.49	
	Simulated Divided Light Grilles	-	-	-	
	Finelight Grilles	0.24	0.19	0.44	
	Full Divided Light Grilles	0.26	0.19	0.44	
<b>400 Series Gliding Windows</b> AND-N-19	Low-E4*	Without Grilles	0.30	0.29	0.49
		Simulated Divided Light Grilles	0.30	0.26	0.43
		Finelight™ Grilles	0.30	0.26	0.43
		Full Divided Light Grilles	0.31	0.26	0.43
	Low-E4 w/HeatLock®	Without Grilles	0.26	0.28	0.48
		Simulated Divided Light Grilles	0.26	0.25	0.42
		Finelight Grilles	0.26	0.25	0.42
		Full Divided Light Grilles	0.28	0.25	0.42
	Low-E4 Sun	Without Grilles	0.30	0.18	0.27
		Simulated Divided Light Grilles	0.30	0.16	0.24
		Finelight Grilles	0.30	0.16	0.24
		Full Divided Light Grilles	0.31	0.16	0.24
	Low-E4 SmartSun™	Without Grilles	0.29	0.19	0.44
		Simulated Divided Light Grilles	0.29	0.17	0.39
		Finelight Grilles	0.29	0.17	0.39
		Full Divided Light Grilles	0.31	0.17	0.39
Low-E4 SmartSun w/HeatLock	Without Grilles	0.26	0.19	0.43	
	Simulated Divided Light Grilles	0.26	0.17	0.38	
	Finelight Grilles	0.26	0.17	0.38	
	Full Divided Light Grilles	0.28	0.17	0.38	
<b>400 Series Elliptical Windows</b> AND-N-16	Low-E4*	Without Grilles	0.27	0.34	0.59
		Simulated Divided Light Grilles	0.27	0.31	0.53
		Finelight™ Grilles	0.29	0.31	0.53
		Full Divided Light Grilles	0.29	0.31	0.53
	Low-E4 w/HeatLock®	Without Grilles	0.23	0.34	0.58
		Simulated Divided Light Grilles	0.23	0.30	0.52
		Finelight Grilles	0.23	0.30	0.52
		Full Divided Light Grilles	0.25	0.30	0.52
	Low-E4 Sun	Without Grilles	0.28	0.21	0.33
		Simulated Divided Light Grilles	0.28	0.19	0.29
		Finelight Grilles	0.29	0.19	0.29
		Full Divided Light Grilles	0.29	0.19	0.29
	Low-E4 SmartSun™	Without Grilles	0.26	0.23	0.53
		Simulated Divided Light Grilles	0.26	0.20	0.48
		Finelight Grilles	0.28	0.20	0.48
		Full Divided Light Grilles	0.28	0.20	0.48
Low-E4 SmartSun w/HeatLock	Without Grilles	0.22	0.22	0.52	
	Simulated Divided Light Grilles	0.22	0.20	0.46	
	Finelight Grilles	0.22	0.20	0.46	
	Full Divided Light Grilles	0.25	0.20	0.46	
<b>400 Series Half Circle Windows</b> Casement AND-N-147	Low-E4*	Without Grilles	0.27	0.35	0.60
		Simulated Divided Light Grilles	0.27	0.32	0.53
		Finelight™ Grilles	0.27	0.32	0.53
		Full Divided Light Grilles	0.28	0.32	0.53
	Low-E4 w/HeatLock®	Without Grilles	0.22	0.34	0.58
		Simulated Divided Light Grilles	0.22	0.31	0.52
		Finelight Grilles	0.22	0.31	0.52
		Full Divided Light Grilles	0.25	0.31	0.52
	Low-E4 Sun	Without Grilles	0.27	0.21	0.33
		Simulated Divided Light Grilles	0.27	0.19	0.30
		Finelight Grilles	0.27	0.19	0.30
		Full Divided Light Grilles	0.29	0.19	0.30
	Low-E4 SmartSun™	Without Grilles	0.26	0.23	0.54
		Simulated Divided Light Grilles	0.26	0.21	0.48
		Finelight Grilles	0.26	0.21	0.48
		Full Divided Light Grilles	0.28	0.21	0.48
Low-E4 SmartSun w/HeatLock	Without Grilles	0.22	0.22	0.53	
	Simulated Divided Light Grilles	0.22	0.20	0.47	
	Finelight Grilles	0.22	0.20	0.47	
	Full Divided Light Grilles	0.24	0.20	0.47	

Andersen® Product	High-Performance Dual-Pane Glass Type	U-Factor <sup>1</sup>	SHGC <sup>2</sup>	VT <sup>3</sup>	
<b>400 Series Circle &amp; Oval Windows</b> AND-N-148	Low-E4*	Without Grilles	0.27	0.35	0.60
		Simulated Divided Light Grilles	0.27	0.32	0.53
		Finelight™ Grilles	0.27	0.32	0.53
		Full Divided Light Grilles	0.28	0.32	0.53
	Low-E4 w/HeatLock®	Without Grilles	0.23	0.34	0.58
		Simulated Divided Light Grilles	0.23	0.31	0.52
		Finelight Grilles	0.23	0.31	0.52
		Full Divided Light Grilles	0.25	0.31	0.52
	Low-E4 Sun	Without Grilles	0.27	0.21	0.33
		Simulated Divided Light Grilles	0.27	0.19	0.30
		Finelight Grilles	0.27	0.19	0.30
		Full Divided Light Grilles	0.29	0.19	0.30
	Low-E4 SmartSun™	Without Grilles	0.26	0.23	0.54
		Simulated Divided Light Grilles	0.26	0.21	0.48
		Finelight Grilles	0.26	0.21	0.48
		Full Divided Light Grilles	0.28	0.21	0.48
Low-E4 SmartSun w/HeatLock	Without Grilles	0.22	0.22	0.53	
	Simulated Divided Light Grilles	0.22	0.20	0.47	
	Finelight Grilles	0.22	0.20	0.47	
	Full Divided Light Grilles	0.24	0.20	0.47	
<b>400 Series Arch Windows</b> AND-N-18	Low-E4*	Without Grilles	0.28	0.33	0.58
		Simulated Divided Light Grilles	0.28	0.30	0.52
		Finelight™ Grilles	0.28	0.30	0.52
		Full Divided Light Grilles	0.29	0.30	0.52
	Low-E4 w/HeatLock®	Without Grilles	0.23	0.32	0.56
		Simulated Divided Light Grilles	0.23	0.29	0.50
		Finelight Grilles	0.23	0.29	0.50
		Full Divided Light Grilles	0.25	0.29	0.50
	Low-E4 Sun	Without Grilles	0.28	0.20	0.31
		Simulated Divided Light Grilles	0.28	0.18	0.28
		Finelight Grilles	0.28	0.18	0.28
		Full Divided Light Grilles	0.29	0.18	0.28
	Low-E4 SmartSun™	Without Grilles	0.27	0.23	0.52
		Simulated Divided Light Grilles	0.27	0.21	0.46
		Finelight Grilles	0.27	0.21	0.46
		Full Divided Light Grilles	0.28	0.21	0.46
Low-E4 SmartSun w/HeatLock	Without Grilles	0.23	0.22	0.51	
	Simulated Divided Light Grilles	0.23	0.20	0.45	
	Finelight Grilles	0.23	0.20	0.45	
	Full Divided Light Grilles	0.25	0.20	0.45	
<b>400 Series Springline™ Windows</b> AND-N-25	Low-E4*	Without Grilles	0.30	0.33	0.57
		Simulated Divided Light Grilles	0.30	0.30	0.51
		Finelight™ Grilles	0.30	0.30	0.51
		Full Divided Light Grilles	0.32	0.30	0.51
	Low-E4 w/HeatLock®	Without Grilles	0.26	0.32	0.56
		Simulated Divided Light Grilles	0.26	0.29	0.50
		Finelight Grilles	0.26	0.29	0.50
		Full Divided Light Grilles	0.28	0.29	0.50
	Low-E4 Sun	Without Grilles	0.31	0.20	0.31
		Simulated Divided Light Grilles	0.31	0.18	0.27
		Finelight Grilles	0.31	0.18	0.27
		Full Divided Light Grilles	0.32	0.18	0.27
	Low-E4 SmartSun™	Without Grilles	0.30	0.23	0.51
		Simulated Divided Light Grilles	0.30	0.21	0.46
		Finelight Grilles	0.30	0.21	0.46
		Full Divided Light Grilles	0.31	0.21	0.46
Low-E4 SmartSun w/HeatLock	Without Grilles	0.25	0.22	0.50	
	Simulated Divided Light Grilles	0.25	0.20	0.45	
	Finelight Grilles	0.25	0.20	0.45	
	Full Divided Light Grilles	0.28	0.20	0.45	

continued on next page

\* "Low-E4" SmartSun," "Low-E4," "Low-E4" Sun" and HeatLock" are Andersen trademarks for "Low-E" glass.  
 1) U-Factor defines the amount of heat loss through the total unit in BTU/hr/ft<sup>2</sup>. °F. The lower the value, the less heat is lost through the entire product. Window values represent non-tempered glass. Use of tempered glass can increase U-Factor ratings. See [andersenwindows.com/nfrc](http://andersenwindows.com/nfrc) for specific performance values. Door values represent tempered glass. 2) Solar Heat Gain Coefficient (SHGC) defines the fraction of solar radiation admitted through the glass both directly transmitted and absorbed and subsequently released inward. The lower the value, the less heat is transmitted through the product. 3) Visible Transmittance (VT) measures how much light comes through a product (glass and frame). The higher the value, from 0 to 1, the more daylight the product lets in over the product's total unit area. Visible Light Transmittance is measured over the 380 to 760 nanometer portion of the solar spectrum.  
 \* NFRC ratings are based on modeling by a third-party agency as validated by an independent test lab in compliance with NFRC program and procedural requirements.  
 \* This data is accurate as of February 2019. Due to ongoing product changes, updated test results, or new industry standards or requirements, this data may change over time. Ratings are for sizes specified by NFRC for testing and certification. Ratings may vary depending on use of tempered glass, different grille options, glass with capillary breather tubes for high altitudes, etc.

### Andersen® NFRC Certified Total Unit Performance (continued)

For current performance information, please visit [andersenwindows.com](http://andersenwindows.com).

Andersen® Product	High-Performance Dual-Pane Glass Type	U-Factor <sup>1</sup>	SHGC <sup>2</sup>	VT <sup>3</sup>	
<b>400 Series Flexiframe® Windows</b> AND-N-17	Low-E4* w/HeatLock®	Without Grilles	0.27	0.33	0.58
		Simulated Divided Light Grilles	0.27	0.30	0.52
		Finelight™ Grilles	0.27	0.30	0.52
		Full Divided Light Grilles	0.28	0.30	0.52
	Low-E4 w/HeatLock®	Without Grilles	0.22	0.32	0.56
		Simulated Divided Light Grilles	0.22	0.29	0.50
		Finelight™ Grilles	0.22	0.29	0.50
		Full Divided Light Grilles	0.25	0.29	0.50
	Low-E4 Sun	Without Grilles	0.27	0.20	0.31
		Simulated Divided Light Grilles	0.27	0.18	0.28
		Finelight™ Grilles	0.27	0.18	0.28
		Full Divided Light Grilles	0.28	0.18	0.28
	Low-E4 SmartSun™	Without Grilles	0.26	0.23	0.52
		Simulated Divided Light Grilles	0.26	0.21	0.46
		Finelight™ Grilles	0.26	0.21	0.46
		Full Divided Light Grilles	0.27	0.21	0.46
	Low-E4 SmartSun™ w/HeatLock®	Without Grilles	0.22	0.22	0.51
		Simulated Divided Light Grilles	0.22	0.20	0.45
Finelight™ Grilles		0.22	0.20	0.45	
Full Divided Light Grilles		0.24	0.20	0.45	
<b>400 Series Complementary Specialty Windows</b> 400 Series Casement, Awning & Picture Windows AND-N-105	Low-E4* w/HeatLock®	Without Grilles	0.29	0.35	0.61
		Simulated Divided Light Grilles	0.29	0.32	0.55
		Finelight™ Grilles	0.29	0.32	0.55
		Full Divided Light Grilles	0.30	0.32	0.55
	Low-E4 Sun	Without Grilles	0.24	0.35	0.60
		Simulated Divided Light Grilles	0.24	0.31	0.54
		Finelight™ Grilles	0.24	0.31	0.54
		Full Divided Light Grilles	0.27	0.31	0.54
	Low-E4 SmartSun™	Without Grilles	0.29	0.22	0.34
		Simulated Divided Light Grilles	0.29	0.20	0.30
		Finelight™ Grilles	0.29	0.20	0.30
		Full Divided Light Grilles	0.30	0.20	0.30
Low-E4 SmartSun™ w/HeatLock®	Without Grilles	0.28	0.23	0.55	
	Simulated Divided Light Grilles	0.28	0.21	0.49	
	Finelight™ Grilles	0.28	0.21	0.49	
	Full Divided Light Grilles	0.29	0.21	0.49	
<b>400 Series Complementary Specialty Windows</b> 400 Series Double-Hung Windows & Patio Doors AND-N-105	Low-E4* w/HeatLock®	Without Grilles	0.28	0.37	0.64
		Simulated Divided Light Grilles	0.28	0.33	0.57
		Finelight™ Grilles	0.28	0.33	0.57
		Full Divided Light Grilles	0.29	0.33	0.57
	Low-E4 Sun	Without Grilles	0.23	0.36	0.62
		Simulated Divided Light Grilles	0.23	0.33	0.56
		Finelight™ Grilles	0.23	0.33	0.56
		Full Divided Light Grilles	0.26	0.33	0.56
	Low-E4 SmartSun™	Without Grilles	0.28	0.22	0.35
		Simulated Divided Light Grilles	0.28	0.20	0.32
		Finelight™ Grilles	0.28	0.20	0.32
		Full Divided Light Grilles	0.29	0.20	0.32
Low-E4 SmartSun™ w/HeatLock®	Without Grilles	0.27	0.24	0.57	
	Simulated Divided Light Grilles	0.27	0.22	0.51	
	Finelight™ Grilles	0.27	0.22	0.51	
	Full Divided Light Grilles	0.28	0.22	0.51	
<b>400 Series Frenchwood® Gliding Patio Doors</b> Two-Panel AND-N-6	Low-E4* w/HeatLock®	Blinds-Between-the-Glass*	0.36	0.24	0.40
		Simulated Divided Light Grilles	0.30	0.23	0.38
		Finelight™ Grilles	0.32	0.23	0.38
		Full Divided Light Grilles	0.32	0.23	0.38
	Low-E4 Sun	Without Grilles	0.27	0.25	0.43
		Simulated Divided Light Grilles	0.27	0.22	0.37
		Finelight™ Grilles	0.27	0.22	0.37
		Full Divided Light Grilles	0.29	0.22	0.37
	Low-E4 SmartSun™	Without Grilles	0.31	0.16	0.24
		Simulated Divided Light Grilles	0.31	0.14	0.21
		Finelight™ Grilles	0.32	0.14	0.21
		Full Divided Light Grilles	0.32	0.14	0.21
Low-E4 SmartSun™ w/HeatLock®	Without Grilles	0.30	0.18	0.39	
	Simulated Divided Light Grilles	0.30	0.16	0.34	
	Finelight™ Grilles	0.31	0.16	0.34	
	Full Divided Light Grilles	0.31	0.16	0.34	
Low-E4 SmartSun™ w/HeatLock®	Without Grilles	0.26	0.17	0.39	
	Simulated Divided Light Grilles	0.26	0.15	0.33	
	Finelight™ Grilles	0.26	0.15	0.33	
	Full Divided Light Grilles	0.29	0.15	0.33	

Andersen® Product	High-Performance Dual-Pane Glass Type	U-Factor <sup>1</sup>	SHGC <sup>2</sup>	VT <sup>3</sup>		
<b>400 Series Frenchwood® Hinged Inswing Patio Doors</b> AND-N-10	Low-E4* w/HeatLock®	Without Grilles	0.30	0.24	0.40	
		Blinds-Between-the-Glass*	0.34	0.24	0.41	
		Simulated Divided Light Grilles	0.30	0.21	0.34	
		Finelight™ Grilles	0.32	0.21	0.34	
	Low-E4 Sun	Without Grilles	0.31	0.21	0.34	
		Simulated Divided Light Grilles	0.27	0.23	0.39	
		Finelight™ Grilles	0.27	0.20	0.34	
		Full Divided Light Grilles	0.29	0.20	0.34	
	Low-E4 SmartSun™	Without Grilles	0.30	0.15	0.22	
		Simulated Divided Light Grilles	0.30	0.13	0.19	
		Finelight™ Grilles	0.32	0.13	0.19	
		Full Divided Light Grilles	0.32	0.13	0.19	
	Low-E4 SmartSun™ w/HeatLock®	Without Grilles	0.30	0.16	0.36	
		Simulated Divided Light Grilles	0.30	0.14	0.31	
		Finelight™ Grilles	0.31	0.14	0.31	
		Full Divided Light Grilles	0.31	0.14	0.31	
	<b>400 Series Frenchwood® Patio Door Sidelights</b> AND-N-64	Low-E4* w/HeatLock®	Without Grilles	0.27	0.16	0.36
			Simulated Divided Light Grilles	0.27	0.14	0.30
Finelight™ Grilles			0.27	0.14	0.30	
Full Divided Light Grilles			0.29	0.14	0.30	
Low-E4 Sun		Without Grilles	0.31	0.22	0.36	
		Simulated Divided Light Grilles	0.31	0.20	0.32	
		Finelight™ Grilles	0.31	0.20	0.32	
		Full Divided Light Grilles	0.32	0.20	0.32	
Low-E4 SmartSun™		Without Grilles	0.27	0.22	0.36	
		Simulated Divided Light Grilles	0.27	0.19	0.31	
		Finelight™ Grilles	0.27	0.19	0.31	
		Full Divided Light Grilles	0.29	0.19	0.31	
Low-E4 SmartSun™ w/HeatLock®	Without Grilles	0.31	0.14	0.20		
	Simulated Divided Light Grilles	0.31	0.13	0.18		
	Finelight™ Grilles	0.31	0.13	0.18		
	Full Divided Light Grilles	0.32	0.13	0.18		
<b>400 Series Frenchwood® Patio Door Transoms</b> AND-N-65	Low-E4* w/HeatLock®	Without Grilles	0.30	0.15	0.33	
		Simulated Divided Light Grilles	0.30	0.14	0.29	
		Finelight™ Grilles	0.31	0.14	0.29	
		Full Divided Light Grilles	0.31	0.14	0.29	
	Low-E4 Sun	Without Grilles	0.27	0.15	0.32	
		Simulated Divided Light Grilles	0.27	0.13	0.28	
		Finelight™ Grilles	0.27	0.13	0.28	
		Full Divided Light Grilles	0.28	0.13	0.28	
	Low-E4 SmartSun™	Without Grilles	0.29	0.24	0.39	
		Simulated Divided Light Grilles	0.29	0.21	0.35	
		Finelight™ Grilles	0.30	0.21	0.35	
		Full Divided Light Grilles	0.30	0.21	0.35	
Low-E4 SmartSun™ w/HeatLock®	Without Grilles	0.27	0.23	0.38		
	Simulated Divided Light Grilles	0.27	0.21	0.34		
	Finelight™ Grilles	0.27	0.21	0.34		
	Full Divided Light Grilles	0.28	0.21	0.34		
Low-E4 Sun	Without Grilles	0.30	0.15	0.22		
	Simulated Divided Light Grilles	0.30	0.13	0.19		
	Finelight™ Grilles	0.30	0.13	0.19		
	Full Divided Light Grilles	0.30	0.13	0.19		
Low-E4 SmartSun™	Without Grilles	0.29	0.16	0.35		
	Simulated Divided Light Grilles	0.29	0.14	0.31		
	Finelight™ Grilles	0.30	0.14	0.31		
	Full Divided Light Grilles	0.30	0.14	0.31		
Low-E4 SmartSun™ w/HeatLock®	Without Grilles	0.26	0.15	0.34		
	Simulated Divided Light Grilles	0.26	0.14	0.30		
	Finelight™ Grilles	0.26	0.14	0.30		
	Full Divided Light Grilles	0.28	0.14	0.30		

continued on next page

\* "Low-E4" SmartSun™, "Low-E4", "Low-E4" Sun and HeatLock® are Andersen trademarks for "Low-E" glass.  
 1) U-Factor defines the amount of heat loss through the total unit in BTU/hr/ft<sup>2</sup>·°F. The lower the value, the less heat is lost through the entire product. Window values represent non-tempered glass. Use of tempered glass can increase U-Factor ratings. See [andersenwindows.com/nfrc](http://andersenwindows.com/nfrc) for specific performance values. Door values represent tempered glass. 2) Solar Heat Gain Coefficient (SHGC) defines the fraction of solar radiation admitted through the glass both directly transmitted and absorbed and subsequently released inward. The lower the value, the less heat is transmitted through the product. 3) Visible Transmittance (VT) measures how much light comes through a product (glass and frame). The higher the value, from 0 to 1, the more daylight the product lets in over the product's total unit area. Visible Light Transmittance is measured over the 380 to 760 nanometer portion of the solar spectrum.  
 • NFRC ratings are based on modeling by a third-party agency as validated by an independent test lab in compliance with NFRC program and procedural requirements.  
 • This data is accurate as of February 2019. Due to ongoing product changes, updated test results, or new industry standards or requirements, this data may change over time. Ratings are for sizes specified by NFRC for testing and certification. Ratings may vary depending on use of tempered glass, different grille options, glass with capillary breather tubes for high altitudes, etc.  
 \*Available for select patio door sizes. Data based on blinds in full open position.

Combination Design, Product Performance & Installation

# PRODUCT PERFORMANCE

## Andersen® NFRC Certified Total Unit Performance (continued)

For current performance information, please visit [andersenwindows.com](http://andersenwindows.com).

Andersen® Product	High-Performance Dual-Pane Glass Type	U-Factor <sup>1</sup>	SHGC <sup>2</sup>	VT <sup>3</sup>	
400 Series Complementary Springline™ & Arch Hinged Inswing Door AND-N-127	Low-E4*	Without Grilles	0.31	0.24	0.41
		Simulated Divided Light Grilles	0.31	0.18	0.30
		Finelight™ Grilles	0.32	0.21	0.35
	Low-E4 w/HeatLock®	Without Grilles	0.28	0.24	0.40
		Simulated Divided Light Grilles	0.28	0.18	0.29
		Finelight Grilles	0.29	0.21	0.34
	Low-E4 Sun	Without Grilles	0.31	0.15	0.23
		Simulated Divided Light Grilles	0.31	0.12	0.17
		Finelight Grilles	0.33	0.13	0.20
	Low-E4 SmartSun™	Without Grilles	0.31	0.16	0.37
		Simulated Divided Light Grilles	0.31	0.12	0.27
		Finelight Grilles	0.32	0.14	0.32
Low-E4 SmartSun w/HeatLock	Without Grilles	0.28	0.16	0.36	
	Simulated Divided Light Grilles	0.28	0.12	0.26	
	Finelight Grilles	0.29	0.14	0.31	
400 Series Complementary Springline™ & Arch Hinged Outswing Patio Door AND-N-127	Low-E4*	Without Grilles	0.32	0.25	0.41
		Simulated Divided Light Grilles	0.32	0.19	0.30
		Finelight™ Grilles	0.33	0.22	0.35
	Low-E4 w/HeatLock®	Without Grilles	0.29	0.24	0.40
		Simulated Divided Light Grilles	0.29	0.18	0.29
		Finelight Grilles	0.30	0.21	0.35
	Low-E4 Sun	Without Grilles	0.32	0.16	0.23
		Simulated Divided Light Grilles	0.32	0.12	0.17
		Finelight Grilles	0.33	0.14	0.20
	Low-E4 SmartSun™	Without Grilles	0.33	0.12	0.17
		Without Grilles	0.31	0.17	0.37
		Simulated Divided Light Grilles	0.31	0.15	0.32
Low-E4 SmartSun w/HeatLock	Without Grilles	0.33	0.15	0.32	
	Without Grilles	0.28	0.16	0.36	
	Simulated Divided Light Grilles	0.28	0.15	0.31	
Low-E4 SmartSun w/HeatLock	Without Grilles	0.29	0.15	0.31	
	Without Grilles	0.31	0.15	0.31	
	Full Divided Light Grilles	0.31	0.15	0.31	
400 Series Complementary Arch Patio Door Sidelights AND-N-131	Low-E4*	Without Grilles	0.31	0.23	0.38
		Simulated Divided Light Grilles	-	-	-
		Finelight™ Grilles	0.31	0.21	0.34
	Low-E4 w/HeatLock®	Without Grilles	0.32	0.18	0.30
		Without Grilles	0.28	0.22	0.37
		Simulated Divided Light Grilles	-	-	-
	Low-E4 Sun	Without Grilles	0.28	0.20	0.33
		Without Grilles	0.32	0.13	0.19
		Simulated Divided Light Grilles	0.30	0.18	0.29
	Low-E4 SmartSun™	Without Grilles	0.33	0.12	0.17
		Without Grilles	0.31	0.15	0.34
		Simulated Divided Light Grilles	-	-	-
Low-E4 SmartSun w/HeatLock	Without Grilles	0.31	0.14	0.30	
	Without Grilles	0.32	0.13	0.27	
	Full Divided Light Grilles	0.32	0.13	0.27	
Low-E4 SmartSun w/HeatLock	Without Grilles	0.28	0.15	0.34	
	Without Grilles	0.28	0.15	0.34	
	Simulated Divided Light Grilles	-	-	-	
Low-E4 SmartSun w/HeatLock	Without Grilles	0.28	0.14	0.30	
	Without Grilles	0.28	0.14	0.30	
	Full Divided Light Grilles	0.30	0.12	0.26	

\* "Low-E4 SmartSun™", "Low-E4™", "Low-E4 Sun" and HeatLock® are Andersen trademarks for "Low-E" glass.  
 1) U-Factor defines the amount of heat loss through the total unit in BTU/hr/ft<sup>2</sup>. °F. The lower the value, the less heat is lost through the entire product. Window values represent non-tempered glass. Use of tempered glass can increase U-Factor ratings. See [andersenwindows.com/nfrc](http://andersenwindows.com/nfrc) for specific performance values. Door values represent tempered glass. 2) Solar Heat Gain Coefficient (SHGC) defines the fraction of solar radiation admitted through the glass both directly transmitted and absorbed and subsequently released inward. The lower the value, the less heat is transmitted through the product. 3) Visible Transmittance (VT) measures how much light comes through a product (glass and frame). The higher the value, from 0 to 1, the more daylight the product lets in over the product's total unit area. Visible Light Transmittance is measured over the 380 to 760 nanometer portion of the solar spectrum.

\* NFRC ratings are based on modeling by a third-party agency as validated by an independent test lab in compliance with NFRC program and procedural requirements.

\* This data is accurate as of February 2019. Due to ongoing product changes, updated test results, or new industry standards or requirements, this data may change over time. Ratings are for sizes specified by NFRC for testing and certification. Ratings may vary depending on use of tempered glass, different grille options, glass with capillary breather tubes for high altitudes, etc.

## Andersen® Products Total Unit Recycled Content Percentages

For current product certificates, please visit [andersenwindows.com](http://andersenwindows.com).

Andersen® Product	% Pre-Consumer Recycled Content
<b>400 Series Windows</b>	
<b>Casement Window</b>	4%
<b>Awning Window</b>	4%
<b>Casement/Awning Picture Window</b>	8%
<b>Complementary Casement Window</b>	5%
<b>Woodwright® Double-Hung Full-Frame Window</b>	13%
<b>Woodwright® Picture Full-Frame Window</b>	14%
<b>Woodwright® Transom Full-Frame Window</b>	13%
<b>Woodwright® Double-Hung Insert Window</b>	9%
<b>Woodwright® Picture Insert Window</b>	11%
<b>Woodwright® Transom Insert Window</b>	10%
<b>Woodwright® Arch Double-Hung Window</b>	9%
<b>Woodwright® Springline™ Single-Hung Window</b>	8%
<b>Tilt-Wash Double-Hung Full-Frame Window</b>	6%
<b>Tilt-Wash Picture Full-Frame Window</b>	10%
<b>Tilt-Wash Double-Hung Insert Window</b>	6%
<b>Gliding Window</b>	4%
<b>Specialty Window</b> (all, based on Flexiframe® windows)	8%
<b>Complementary Specialty Window</b> (rectangular)	7%
<b>400 Series Patio Doors</b>	
<b>Frenchwood® Gliding Patio Door</b>	4%
<b>Frenchwood® Hinged Inswing Patio Door</b>	4%
<b>Frenchwood® Patio Door Sidelight</b>	3%
<b>Frenchwood® Patio Door Transom</b>	3%
<b>Complementary Springline™ Hinged Inswing Patio Door</b>	3%
<b>Complementary Arch Hinged Inswing Patio Door</b>	3%

\* "% Pre-Consumer Recycled Content" is verified by SCS Global Services (SCS) to meet ISO 14021 standards based on NFRC sizing. Actual recycled content dependent on product size.

**About the NFRC**

The National Fenestration Rating Council (NFRC) is a nonpartisan coalition of professionals whose purpose is to provide fair, accurate and credible energy performance ratings for fenestration products. NFRC's membership includes manufacturers, suppliers, designers, specifiers, utility companies, government agencies and other building industry representatives.

Andersen Corporation is a founding member of the NFRC and continues to support its work by providing fair, accurate and credible energy performance ratings to consumers and the building industry. If you have any questions about the NFRC, its program or energy performance ratings, write them at: NFRC, 6305 Ivy Lane, Suite 140, Greenbelt, MD 20770, Tel: (301) 589-1776 Website: [www.nfrc.org](http://www.nfrc.org)

**About the Label**

Look for this certification label on every window and patio door you buy. The NFRC section was designed by the National Fenestration Rating Council to provide accurate information that helps you promote the energy efficiency of the homes you build. These ratings allow you – and your customers – to measure and compare the energy performance of similar products. If the product does not have this label, the NFRC has not verified its claims.

Combination Design, Product Performance & Installation

Do not remove until final code inspection. Save label for future reference.

ENERGY STAR® Certified in Highlighted Regions  
Certifié ENERGY STAR dans les régions en surbrillance

Canada  
energystar.gc.ca



ENERGY STAR

U.S. / É.U.  
energystar.gov

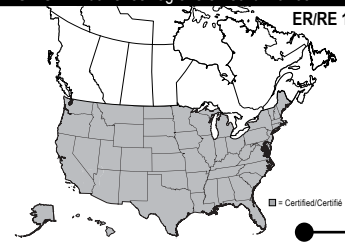

ER/RE 18

DO NOT REMOVE UNTIL FINAL INSPECTION / NE PAS RETIRER AVANT L'INSPECTION FINALE

NFRC  
National Fenestration Rating Council®  
CERTIFIED

WINDOWS • DOORS  
**Andersen** AW

Casement Window  
AND-N-1-01592-00001  
Vinyl-Clad Wood Frame, Dual-Pane Low-E SmartSun  
Glazing with Argon  
Product Type: Casement

**ENERGY PERFORMANCE RATINGS**

U-Factor <b>0.27</b> (U.S./I-P)	Solar Heat Gain Coefficient <b>0.21</b>
<b>1.53</b> (Metric/SI)	

**ADDITIONAL PERFORMANCE RATINGS**

Visible Transmittance <b>0.49</b>	
--------------------------------------	--

Manufacturer stipulates that these ratings conform to applicable NFRC procedures for determining whole product performance. NFRC ratings are determined for a fixed set of environmental conditions and a specific product size. NFRC does not recommend any product and does not warrant the suitability of any product for any specific use. Consult manufacturer's literature for other product performance information.  
[www.nfrc.org](http://www.nfrc.org)

WDMA  
Hallmark Certified  
[www.wdma.com](http://www.wdma.com)

Licensee: 129-H-861  
Andersen Corporation  
400 Series Casement Window  
Manufacturer stipulates Hallmark Certification as indicated below.

STANDARD	RATING
AAMA-WDMA/CSA 1011.S.2/A440-11	Class LC-PG50 - Size Tested 56" x 71" DP+50/-50
AAMA-WDMA/CSA 1011.S.2/A440-08	Class LC-PG50 - Size Tested 56" x 71" DP+50/-50
AAMA-WDMA/CSA 1011.S.2/A440-08 A440S1-09	Class LC-PG50 - 1435mm x 1622mm Positive/Negative Design Pressure (DP) = 2400 Pa/2400 Pa Water Penetration Resistance Test Pressure = 360 Pa Canadian Air Infiltration/Exfiltration = A3

FL 12496  
Glazing: 2.2mm AN outer/2.3mm HS inner

**WARNING**  
This product can expose you to chemicals including titanium dioxide, which is known in the state of California to cause cancer, and methanol, which is known in the state of California to cause birth defects or other reproductive harm. For more information go to [www.P65Warnings.ca.gov](http://www.P65Warnings.ca.gov)

Meets or exceeds CEC & IECC Air Infiltration Requirements of 0.2 CFM/sq. ft. or lower.  
WDMA Hallmark Certification Program. Complies with HUD UM Bulletin No. 111.

**U-Factor** indicates how well a product prevents heat from escaping (the lower the number, the better).

**Visible Transmittance** refers to how much visible light comes through a product (the closer to 1.0, the more light is transmitted).

**WDMA Hallmark Certification** verifies the performance ratings of this product were tested by an independent testing laboratory and verified by a third-party certification program.

**Test Standards**

**Energy Rating (ER)** represents "Energy Rating" and is a rating used in Canada for product comparison purposes (the higher the ER number, the more energy saved during the heating season).

**ENERGY STAR® Climate Zone Map** is based on U-Factor and solar heat gain coefficient criteria for specific ENERGY STAR climate zones within the United States and Canada. The shading of the map shows which climate zone(s) a particular product and glass type is ENERGY STAR certified in.

**Solar Heat Gain Coefficient** measures how well a product blocks heat caused by sunlight (the lower the number, the more it will help reduce the use of air conditioning and as a result reduce electrical bills and energy use).

**Performance Grade (PG) and Design Pressure (DP) Ratings**

**Glass Construction** used with this product type

\* NFRC ratings are based on modeling by a third-party agency as validated by an independent test lab in compliance with NFRC program and procedural requirements.



# THE ENVIRONMENT HAS A BUSINESS PARTNER

Respect for the environment is nothing new at Andersen. For more than a century, it's been part of who we are. Our commitment to recycle and reclaim materials began simply because it was good business. Now it's part of our commitment to sustainability and responsible stewardship of all our resources. Andersen is committed to providing you with long-lasting,\* energy-efficient windows and patio doors. Visit [andersenwindows.com/sustainability](http://andersenwindows.com/sustainability) for more information.



Andersen® products are certified under the National Fenestration Rating Council's voluntary third-party certification program designed to ensure accurate energy performance ratings and labeling.



Andersen was one of the first U.S. window manufacturers to receive Forest Stewardship Council® (FSC) Chain-of-Custody certification (FSC-CO16636). This certification is awarded to companies that meet FSC standards for traceability in their wood supply chain.



The Window & Door Manufacturers Association (WDMA) Hallmark Certification program includes product testing and quality-control process audits to verify that Andersen windows and doors are produced in conformance with the industry standards for air, water resistance and structural performance.



Andersen was the first window manufacturer to certify our products for indoor air quality, beginning in 2008. Our Indoor Advantage™ Gold certification by SCS Global Services (SCS) meets the rigorous high standards for healthier indoor air quality set by the California Specification 01350.



Under U.S. Green Building Council (USGBC) guidelines, Andersen is able to claim a percentage of material in its Fibrex® product as pre-consumer recycled content. SCS Global Services (SCS) has certified this amount for Andersen.



Andersen Corporation is proud to be an ENERGY STAR® partner. For over 115 years, Andersen has built a reputation for environmental stewardship and energy-efficient products. In fact, Andersen has been part of the ENERGY STAR program since it started and was the first window manufacturer to be named an ENERGY STAR National Window Partner of the Year in 1999.

\* Visit [andersenwindows.com/warranty](http://andersenwindows.com/warranty) for details. All logos and marks are trademarks of their respective owners.

# Andersen® windows and doors can make significant contributions to the success of sustainable design strategies.

As a charter member of the U.S. Green Building Council, we are active supporters of certified green buildings. Our products can help customers in pursuing green building programs, such as Leadership in Energy and Environmental Design (LEED®), the National Green Building Standard, Green Globes, GreenStar and more.

Below is an overview of how our products may assist project teams with pursuing LEED v4 or the NAHB National Green Building Standard rating systems. More detailed credit summaries, as well as information about how Andersen products can support earlier versions of LEED certification (e.g., LEED v3 or LEED 2008), are available at [andersenwindows.com](http://andersenwindows.com).

## LEED v4 FOR BUILDING DESIGN AND CONSTRUCTION: NEW CONSTRUCTION AND MAJOR RENOVATIONS

### Integrative Process Credit: Energy & Atmosphere

- Minimum energy performance prerequisite
- Optimize energy performance credit
- Renewable energy production credit
- Green power and carbon offsets credit

### Materials & Resources

- Construction and demolition waste management planning credit
- Building product disclosure and optimization sourcing of raw materials credit
- Construction and demolition waste management credit

### Indoor Environmental Quality

- Minimum indoor air quality performance prerequisite
- Minimum acoustic performance prerequisite – schools
- Enhanced indoor air quality strategies credit
- Low-emitting materials credit
- Thermal comfort credit
- Daylight credit
- Quality views credit
- Acoustic performance credit (option 2)

## LEED v4 FOR BUILDING DESIGN AND CONSTRUCTION: HOMES AND MULTI-FAMILY MIDRISES

### Energy & Atmosphere

- Minimum energy performance prerequisite
- Education of the homeowner, tenant or building prerequisite
- Annual energy use credit
- Building orientation for passive solar credit
- Air Infiltration credit
- Windows credit

### Materials & Resources

- Durability management prerequisite
- Environmentally preferable products credit
- Construction waste management credit

### Indoor Environmental Quality

- Ventilation prerequisite
- Low-emitting products credit

## ANSI ICC/ASHRAE 700-2015 NATIONAL GREEN BUILDING STANDARD

NGBS section numbers are referenced in parentheses.

### Resource Efficiency

- Prefinished materials (601.7)
- Flashing (602.12)
- Exterior doors, including storm doors (602.1.10)
- Recycled construction materials (605.3)
- Bio-based products (606.1)
- Wood-based products (606.2)
- Manufacturer's environmental management system concepts (611.1)

### Energy Efficiency

- Mandatory requirements (701.1)
- Building thermal envelope air sealing (701.4.3.1)
- Multi-family air leakage alternative (701.4.3.3)
- Fenestration air leakage (701.4.3.4)
- ICC IECC analysis (702.2.1)
- Energy performance analysis (702.2.2)
- UA improvement (703.2.1)
- Fenestration (703.2.5)
- Sun-tempered design (703.7.1)
- Passive cooling design (703.7.3)
- Passive solar heating design (703.7.4)

### Indoor Environmental Quality

- Wood materials (901.4)
- Interior architectural coatings (901.9)
- Interior adhesives & sealants (901.10)
- Operable windows & sliding glass doors (902.1.5)

### Energy Efficient

- Homeowner's manual (1001.1)
- Building construction manual (1002.1)

# INSTALLATION ACCESSORIES

Listed are optional accessories available for the installation of Andersen® windows and doors. You'll also find key considerations regarding the use and installation of every Andersen product. Keep the instruction guidelines and safety information in mind when considering the installation and use of any Andersen product. Should you have any questions, contact your local Andersen supplier. Thank you for considering and using Andersen products.

## COIL STOCK

Andersen aluminum coil stock can be ordered to match any of our 11 trim colors. Made from .018" thick aluminum, coil stock is available in 24" (610) x 50' (15240) rolls. Color-matched 1 1/4" (32) stainless steel trim nails are also available and can be ordered in 1 lb/.454 kg boxes.



## FIBREX® TRIM BOARD



Andersen offers a 3 1/2" (89) wide by 3/4" (19) thick cellular Fibrex® trim board in 10' (3048) lengths. Available in the same 11 colors as the exterior trim system, this solid trim board can be cut or ripped to size and can be fastened using nails or screws.

## CONTINUOUS DRIP CAP

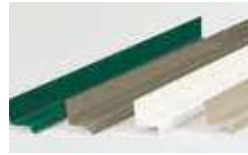

Included on 400 Series windows with vertical (ribbon) joins. Heavy 24-gauge corrosion-resistant aluminum construction. Available in 6' (1829), 10' (3048) and 12'-7 1/8" (3848) lengths and in any of the 11 trim colors.

## AUXILIARY CASING



Auxiliary casing is made of cellular Fibrex material. Available in white, canvas, Sandtone, Terratone, forest green, dark bronze and black. Dimensions are 1 3/16" (30) by 1 13/16" (30) in 150" (3810) lengths.

## VINYL CHANNELS

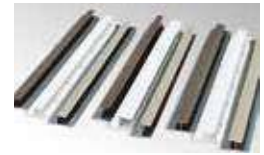

Rigid vinyl "J," "h" and "H" channels are available in white, Sandtone and Terratone.

## EXTENSION JAMBS



Available for most Andersen products. See individual sections for details.

## COLOR-MATCHED SEALANT

Color-matched sealant is available in Andersen exterior colors. This high-quality sealant can be used during the installation of all Andersen products.

	COLOR	LENGTH	DEPTH	WIDTH
<b>Fibrex Trim Board</b>	11 colors	120" (3048)	3/4" (19)	3 1/2" (89)
<b>Auxiliary Casing</b>	6 colors	150" (3810)	1 3/16" (30)	1 3/16" (30)
<b>Rigid Vinyl "H" Channel</b>	W	84" (2134) & 150" (3810)	3/4" (19)	1" (25)
	S,T	84" (2134) & 150" (3810)	3/4" (19)	3/4" (19)
<b>Rigid Vinyl "h" Channel</b>	W,S,T	150" (3810)	1/2" (13)	1" (25)
<b>Rigid Vinyl "J" Channel</b>	W,S,T	150" (3810)	1/2" (13)	3/4" (19)

# INSTALLATION INFORMATION

## ROUGH OPENINGS

The purpose of a rough opening is to allow for proper spacing between the window or patio door unit and the building structure. The space is required for locating, leveling and squaring the unit during installation and to provide an area for insulation. A rough opening that is incorrectly sized may affect unit operation and may not allow for adequate fastening of the unit to the building structure. Andersen rough opening dimensions are provided as a guideline to help determine the minimum amount of space needed between the window or patio door and the building structure. See appropriate product sections for rough opening guidelines for each product.

Keep in mind that rough opening dimensions may need to be altered from published guidelines, depending on installation methods, joining methods, replacement methods, etc. For example, flashing systems can reduce the amount of available rough opening space and should be factored in when calculating rough opening dimensions. The use of support or joining materials will encroach on the rough opening and may require additional rough opening space between the unit and the building structure, depending on the thickness of the flashing system and joining materials used. To facilitate drainage, the rough opening sill plate should never slope toward the interior. For challenging environments and other information, refer to Energy and Environmental Building Association's (EEBA) Water Management Guide ([www.eeba.org](http://www.eeba.org)).

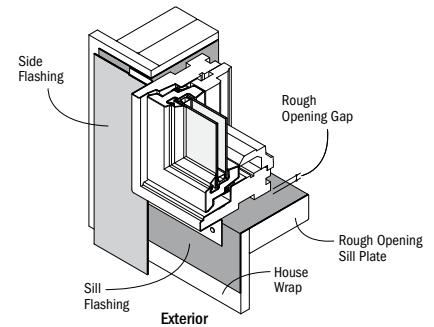
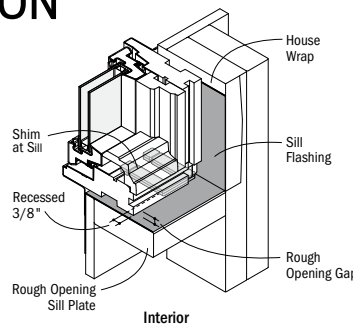

Example of window sill flashing in a membrane drainage system.

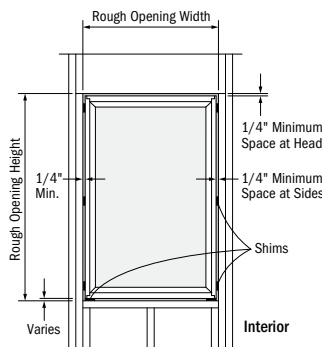

Example of window unit installed using Andersen published minimum rough opening dimensions.

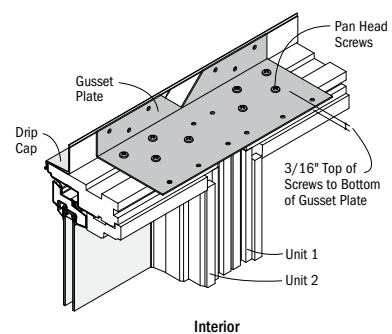

Example of two units joined together with the use of gusset plates and pan head screws that will require additional rough opening space.

## IMPORTANCE OF PROPER INSTALLATION

Proper installation and maintenance of Andersen products are essential to attain optimum performance and operation. Installation instructions are available by visiting [andersenwindows.com](http://andersenwindows.com). Remember that every installation is different and Andersen strongly recommends consultation with the local supplier or an experienced contractor, architect or structural engineer prior to the installation of any Andersen product. The method of attachment for Andersen products, fastener selection and code compliance are the responsibility of the architect, building owner, contractor, installer and/or consumer. For more complete installation details, visit [andersenwindows.com](http://andersenwindows.com) or see your Andersen supplier.

\* Dimensions in parentheses are in millimeters.

**GENERAL NOTES**

When ordering, make certain you specify, then verify, the exact product, unit dimensions, configuration requirements, color and options you desire on each window or patio door. Before installing the product, we suggest you verify that it includes the features and options you ordered. Visit [andersenwindows.com](http://andersenwindows.com) for product installation and joining guides. Printing limitations prohibit exact color duplication of products. View actual samples for building specifications. Andersen Corporation reserves the right to change details, specifications or sizes without notice. The customer assumes all risk of alterations made to Andersen® products.

**CODES**

Appropriate selection of Andersen products that conform to all applicable laws, ordinances, building codes and safety requirements is the sole responsibility of the architect, designer, building owner and/or contractor. Check with your local building code officials for specific information. Unit wind load, performance grade and energy performance information is provided on pages 181-207. For up-to-date product performance information, visit [andersenwindows.com](http://andersenwindows.com). The performance of any building system depends on the design and construction of the building system in its entirety, which should meet building code requirements as well as address product and material limitations and local environment and climate.

**DRIP CAPS**

Drip caps are a specific type of flashing or trim that is used at the head of a window or door to direct water from the drainage plane out beyond the face of the unit.

**FLASHING**

Flashing is an important element in a building's water management system. It is used to shed and direct water to the building exterior or to the drainage plane. Flashing materials are typically applied starting from the bottom and working upward, with each successive layer overlapping the previous one in shingle fashion. Water infiltration problems in any type of building can be reduced by properly flashing and/or sealing around all building openings, including windows and doors.

**USE OF SHIMS**

Shims are often used along the side jambs of windows and doors to center the unit in the rough opening and to position it plumb, level and square. In addition, shims are always required for windows under the sill at the side jambs to lift it off the rough sill. Shims also enable a straight frame for proper weatherstrip contact and unit operation. If not placed properly, unit performance and operation can be affected. Use waterproof shims capable of supporting the weight of the product. When using tapered shims, use them in pairs with the tapers opposing each other to avoid tilting the unit or twisting (rotating) of the jambs.

**SEALANTS**

Sealants are elastic materials used to block the passage of water and/or air while allowing movement between the two sides of the joint. A sealant should bond tightly and be able to expand and contract to accommodate joint movement without cracking or tearing away from the substrate. Surfaces must be clean, dry and sound for adequate sealant adhesion. Choose a sealant that is compatible with, and that will adhere adequately to, all building materials used in the window and patio door area. Proper sealant joint design is based upon the expected movement of adjacent materials and the movement capability

of the sealant. A general rule of thumb is that the depth of the sealant joint should be equal to half the width ( $D = W/2$ ), but generally not less than 1/4" (6) or more than 1/2" (13). Foam-plastic backer rod can be used to limit the depth of the sealant joint, to provide a backstop for tooling the sealant without damage to the bond. It also acts as a bond breaker to help minimize stress in the sealant. Sealants should be maintained seasonally and repaired and/or replaced as needed.

**GENERAL INSTALLATION GUIDELINES**

1. Read and follow the installation guide in its entirety.
2. Decide whether you are integrating to a surface barrier or a membrane drainage system before installing the product. The appropriate method for your installation may vary based on building design, application and industry practices.
3. Make certain the drainage plane is continuous (proper overlaps to shed water, taped seams, etc.).
4. Andersen products should be installed only in the vertical position.
5. Check the rough opening to make sure it is sized properly, is square and is level.
6. Install the window or door plumb.
7. Install the window or door level.
8. Install the window or door square. Diagonal measurements should be within 1/8" (3).
9. Follow installation instructions to properly locate shims and to make sure that units are plumb, level and square. Shims are always required under the window jambs at the sill and along the jambs on the sides for windows and doors.
10. Check for squareness of unit before final anchoring of the product into the wall.
11. Anchor window as directed with appropriate fasteners.
12. Integrate the window or door into the drainage plane of the wall using quality flashing and sealing materials. All flashing materials should be properly overlapped to shed water.
13. Allow 1/4" (6) minimum space for a sealant joint around perimeter of unit between exterior finish materials and unit.
14. Insulate and seal the interior cavity between the window or door frame and the rough opening.
15. Check unit operation before application of interior trim.
16. Stain and/or seal all unfinished wood surfaces promptly to minimize moisture absorption.

**EXTERIOR PAINTING/SEALING OF ANDERSEN PRODUCTS**

The exterior of some Andersen products may be painted or stained. However, improper painting and staining may cause damage to vinyl, aluminum and other exterior materials. Please refer to the individual product sections for details on painting Andersen product exteriors.

**CAUTIONS**

1. Do not apply any type of film to insulating glass. Thermal stress and glass damage can result. Andersen Corporation is not responsible for product performance when films are applied to Andersen products.
2. The use of removable insulating materials such as insulated window coverings, shutters and other shading devices may also cause thermal stress conditions and/or deformation of protective vinyl. In addition, excessive condensation may result, which can have a deteriorating effect on the window or patio door unit(s) involved. Andersen Corporation is not responsible

for product performance when these kinds of materials or devices are applied to or used in conjunction with Andersen products.

3. In wall construction utilizing brick facades, leave adequate clearance between sill, jambs and brick for sealing and dimensional change of framework.
4. Acid solutions commonly used to wash brick and other masonry materials will damage glass, fasteners, hardware and metal flashing. Protect unit and follow cleaning product instructions carefully. Damage caused by acid solution is not covered under the Andersen limited warranty.
5. Andersen windows may be combined in almost unlimited ribbons or stacks if each unit is positively secured to structural elements on opposing sides and if the proper joining system is used. See page 181 for more information.

**SAFETY GLASS**

Unless specifically ordered, Andersen windows are not made with safety glass and, if broken, the glass could fragment, causing injury. Andersen windows may be ordered with tempered glass which may reduce the likelihood of injury when broken. All Andersen patio doors are made with tempered glass. Differences in appearance between tempered and non-tempered glass can be expected. Slight visual distortions may be noticeable and occur normally as a result of the tempering process. Building codes require safety glass in locations adjacent to or near doors and other locations.

**WINDOW AND PATIO DOOR SAFETY**

Windows may provide a secondary avenue of escape or rescue in an emergency, such as a fire. Every family should develop an escape plan and make sure family members know how to escape from the home in an emergency. In your plan, include two ways to escape from every room in case one way is blocked by fire or smoke, and make sure you have a designated meeting place outside. A window or a door is an alternate means of escape or rescue. Practice your plan until each member of the family understands it and is able to escape without assistance. Remember, you may not be able to reach children during a fire emergency. Teach children – even very young children – that they must escape from a fire in the home and never hide from the fire or from emergency personnel.

**LOOKOUT FOR KIDS® PROGRAM**

The Consumer Product Safety Commission has said: "Keep children away from open windows to prevent falls. Don't depend on insect screens to keep the child from falling out of the window. They are designed to keep insects out, not children in. Avoid placing furniture near windows to keep children from climbing to a window seat or sill." In an effort to educate consumers about the potential for child falls from windows, Andersen Corporation created the LookOut For Kids Program. It combines a window and door safety brochure and specific product instructions to help make window and door safety an important priority for consumers. For more information on child safety, write:

Andersen Corporation  
**LookOut For Kids Program**  
100 Fourth Avenue North  
Bayport, MN 55003

Call: 1-800-313-8889 Email: [lofk@andersencorp.com](mailto:lofk@andersencorp.com)



\*Dimensions in parentheses are in millimeters.

Combination Design,  
Product Performance  
& Installation

# NOTES

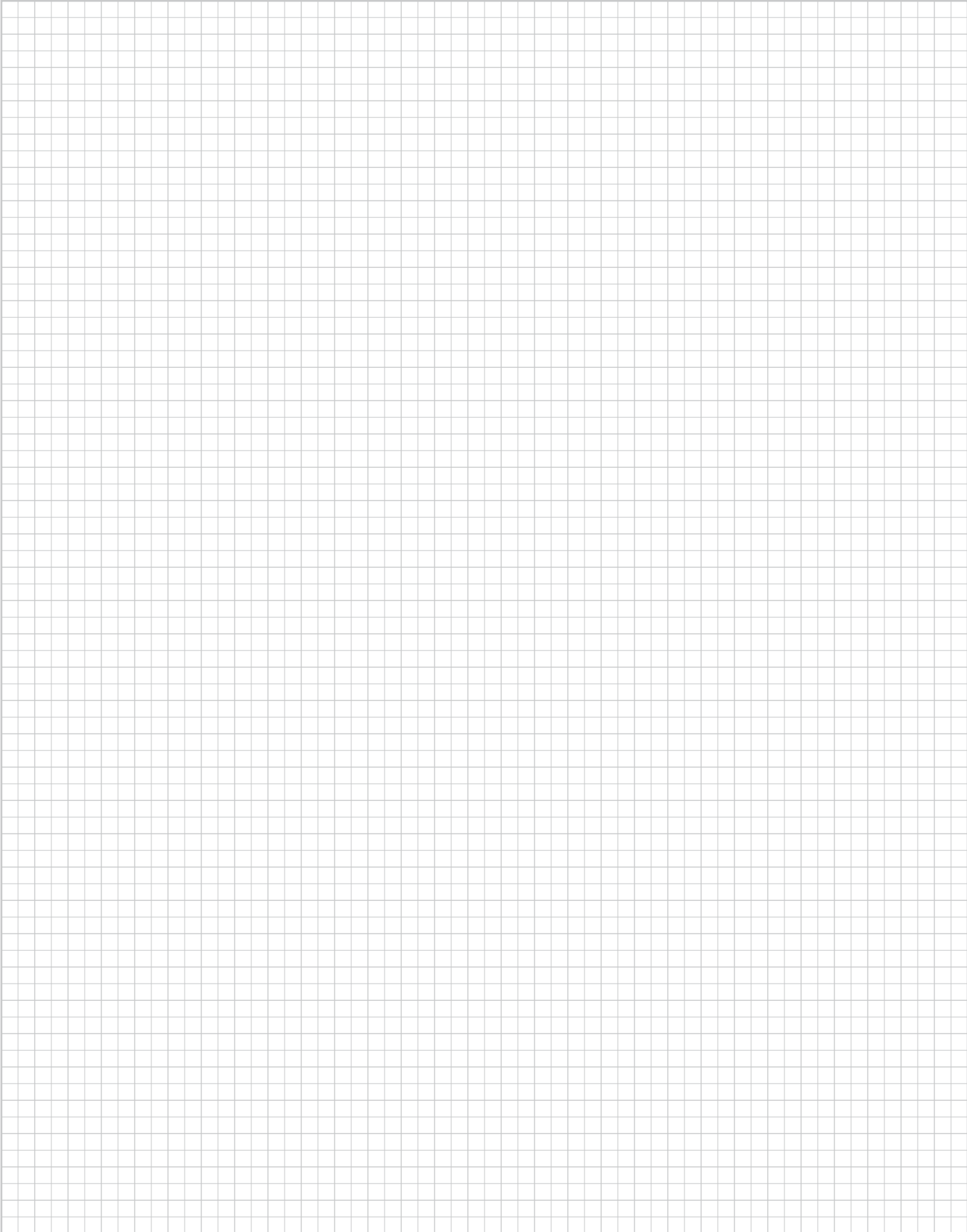



89 400 Series Tilt-Wash Double-Hung Insert Windows	87 400 Series Narroline® Conversion Kit	75 400 Series Tilt-Wash Double-Hung Full-Frame Windows	67 400 Series Woodwright Double-Hung Insert Windows	47 400 Series Woodwright® Double-Hung Full-Frame Windows	41 400 Series Complementary Casement Windows	37 400 Series Replacement Casement & Awning Windows	19 400 Series Casement & Awning Windows
163 400 Series Complementary Curved Top Patio Doors	159 400 Series Frenchwood Patio Door Sidelights & Transoms	149 400 Series Frenchwood Hinged Inswing Patio Doors	141 400 Series Frenchwood® Gliding Patio Doors	137 400 Series Complementary Specialty Windows	117 400 Series Specialty Windows	111 400 Series Gliding Windows	97 400 Series Bay & Bow Windows
					181 Combination Designs, Product Performance & Installation	175 Exterior Trim	173 Art Glass



All trademarks where denoted are marks of their respective owners.  
 "Andersen" and all other marks where denoted are trademarks of Andersen Corporation.  
 ©2019 Andersen Corporation. All rights reserved. 03/19 Part #110003



## PDF NAVIGATION TIPS

Welcome to an overview of the enhanced navigation tools available in this PDF. Here are some simple tips on PDF navigation. Before you begin be sure you are using the latest version of Adobe Acrobat Reader DC, available at – <https://get.adobe.com/reader/>

To watch a 3-minute tutorial on navigating catalog PDFs, go to: <https://youtu.be/sWWnYn6ON3Y>

### BOOKMARK NAVIGATION

①

Acrobat will display the bookmarks panel when you open the PDF.

**Bookmarks** are the easiest way to find specific product information.

Select a topic and that page will be displayed.

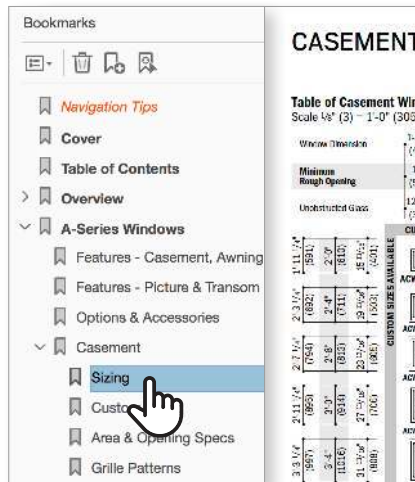

②

If you need to print a specific section, **right click on that section** within in the bookmarks panel and choose “**Print Section.**”

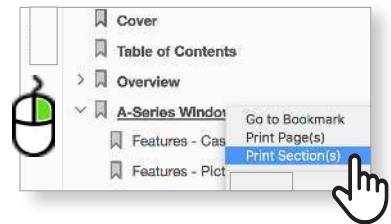

### LINKS AND URL NAVIGATION

①

You can also use the **embedded links** to navigate between sections. All links are underlined in blue.



②

Website links automatically open in your web browser.



Add additional navigation tools by adjusting the default settings in Acrobat.

## TOOL BAR NAVIGATION

1

To add a **“Jump Back” Button** to your tool bar, **Right click on tool bar**, select **Show Page Navigation Tools** and choose **Show All Page Navigation Tools**.

Right and left facing arrows are added to the tool bar allowing you to go back or forward to the last page you viewed.

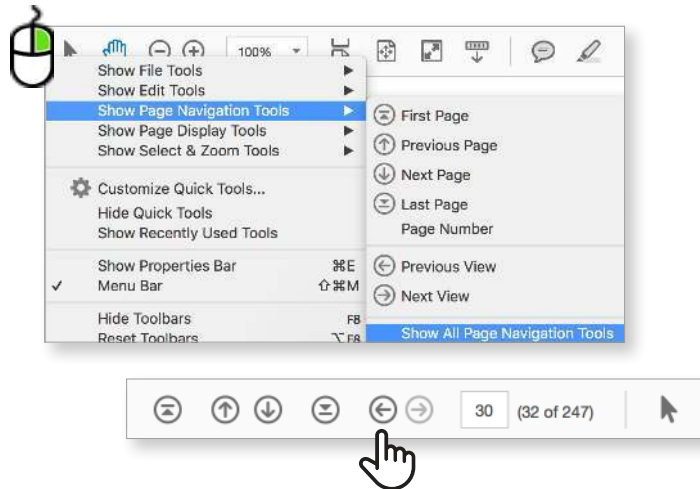

2

Another helpful tool is the **Loupe Tool**. It allows you to zoom in on the page without having to increase the page size.

To add a **Loupe Tool** to your tool bar, **right click on tool bar**, select **Show Select & Zoom Tools** and then choose **Show All Select & Zoom Tools**.

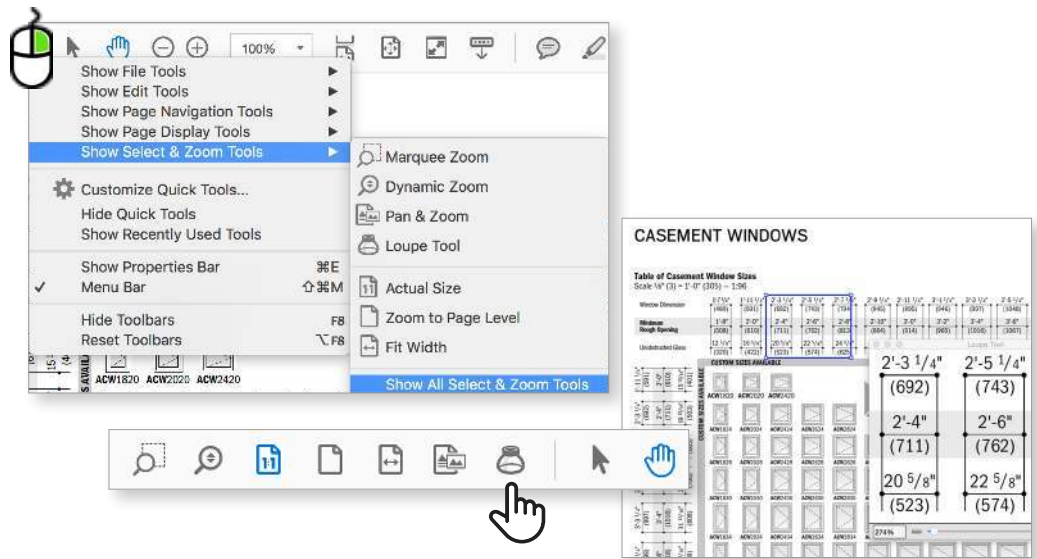

3

You can also use the **commenting tools**. Add a post-it-note with your comments or highlight important information.

Be sure to save the file.



To watch a 3-minute tutorial on navigating catalog PDFs, go to: <https://youtu.be/sWWnYn60N3Y>

We are always looking for ways to improve.  
Please send feedback to [webmarketing@andersencorp.com](mailto:webmarketing@andersencorp.com).