

200 SERIES



THE WARMTH OF
WOOD AT AN
**UNCOMMON
VALUE**

CONTENTS

Performance	2
Exteriors & Interiors	3
Exterior Trim System	4
Glass	5
Andersen® 200 Series Windows	6
Window Hardware	7
Andersen 200 Series Patio Doors	9
Andersen Patio Door Hardware	10
Designer Hinged Door Hardware	12
Grilles & Insect Screens	15
Comparison Chart	16

200 SERIES WINDOWS

Tilt-Wash Double-Hung Windows	17
Gliding Windows	23

200 SERIES PATIO DOORS

Narroline® Gliding Patio Doors	29
Perma-Shield® Gliding Patio Doors	37
Hinged Inswing Patio Doors	43

Exterior Trim	51
---------------------	----

Combination Designs	57
Product Performance	65
Installation Accessories & Materials	73
Installation Information	74
Environment & Sustainability	76

For warranty information, visit andersenwindows.com/warranty.



Andersen Corporation, including its subsidiaries, has been named a 2024 ENERGY STAR® Partner of the Year – Sustained Excellence Award winner, the highest honor given by ENERGY STAR, for continued leadership in protecting the environment through superior energy efficiency achievements.



AMERICA'S MOST LOVED BRAND OF WINDOWS & DOORS*

You want to give your customers a home they love, and we're here to make that easy for you. That's why we're proud to offer you products that rate #1 in quality and performance,** and to be the #1 trusted and recommended window and door brand** by pros.

200 SERIES PRODUCTS

The 200 Series product line is the best place to start if you're looking for simple, clad-wood windows. It's focused only on our most popular sizes and options to deliver uncommon value while still living up to our high-quality design and performance standards.

*2022 Andersen brand surveys of U.S. realtors, contractors, builders and homeowners.

**2022 Andersen brand surveys of U.S. contractors, builders, architects and homeowners.

PERFORMANCE

Our 200 Series products deliver Andersen quality at an uncommon value. Built from wood with our Perma-Shield® exterior cladding, they offer durability, long-term beauty and options to fit your project needs. And like all Andersen® products, they're supported by over 120 years of commitment to quality and service.

DESIGN

200 Series windows and patio doors are designed with narrow profiles to maximize light and views.

RIGOROUSLY TESTED

The exclusive Andersen Perma-Shield system gives our windows and patio doors a tough, protective shell that safeguards the wood inside. It repels water, resists dents* and stays beautiful for years.

LOW MAINTENANCE, NEVER NEEDS PAINTING

The Perma-Shield exteriors offer superior weather resistance and are virtually maintenance free.

ENERGY-SAVING GLASS FOR ANY CLIMATE

Andersen makes windows and patio doors with options that make them ENERGY STAR® v. 7.0 certified throughout the United States.

Visit andersenwindows.com/energystar for more information and to verify the product with your glass option is certified in your area.



KEEPS THE WEATHER OUT

Weather-resistant construction and careful selection of weatherstripping by product types seal out drafts, wind and water, whatever the weather.

PERFORMANCE GRADE (PG) UPGRADE FOR PERMA-SHIELD® GLIDING PATIO DOORS

PG upgrade is available for select 200 Series Perma-Shield gliding patio doors. Products with PG upgrade achieve higher air, water and structural ratings as opposed to standard products.

QUALITY SO SOLID, THE WARRANTY IS TRANSFERABLE*

Many other window and door warranties end when a home is sold, but our coverage – 20 years on glass, 10 years on non-glass parts – transfers from each owner to the next. And because it's not prorated, the coverage offers full benefits year after year, owner after owner. So it can add real value when you decide to sell your home.



*Visit andersenwindows.com/warranty for details.

"ENERGY STAR" is a registered trademark of the U.S. Environmental Protection Agency.



EXTERIORS & INTERIORS

200 Series Tilt-Wash Double-Hung & Gliding Windows

EXTERIOR COLORS

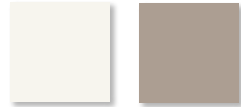

White Sandtone

INTERIOR OPTIONS



Pine White

200 Series Narroline® Gliding Patio Doors

EXTERIOR COLORS



White Canvas Sandtone Terratone Dark Bronze Black

INTERIOR WOOD SPECIES & INTERIOR PAINT COLORS



Pine Maple Oak White Dark Bronze Black

Painted interiors are on pine.

200 Series Perma-Shield® Gliding Patio Doors

EXTERIOR & INTERIOR COLORS



White Canvas Sandtone Terratone Dark Bronze Black

Interior color will match the exterior color selected.

200 Series Hinged Inswing Patio Doors

EXTERIOR COLORS



White Sandtone Terratone

INTERIOR COLOR

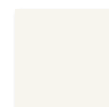

White

Printing limitations prevent exact duplication of colors. See your Andersen supplier for actual color samples. Naturally occurring variations in grain, color and texture of wood make each window one of a kind. All wood interiors are unfinished unless a finish is specified.

EXTERIOR TRIM SYSTEM

Add curb appeal with Andersen® exterior trim. Our trim is made with Fibrex® material, an environmentally smart composite that contains 40% pre-consumer recycled wood fiber by weight.



Time saving and cost effective

Innovative attachment strip

No nail holes, no visible fasteners, no painting

Independent of water management system for easy installation

Style that gets noticed

Our wide trim profiles overlap the window frame to create clean lines without visible sealant joints. Mitered brick mould corners and butt joints on flat casing profiles reflect traditional corner joints.



Cocoa bean trim with Sandtone window*

Visit andersenwindows.com/exteriortrim to learn more.

EXTERIOR TRIM COLORS



*Exterior trim shown with an Andersen 400 Series casement window.

Printing limitations prevent exact duplication of colors. See your Andersen supplier for actual color samples.

GLASS

Andersen has the glass you need to get the performance you want. Check with your supplier for the selections that meet ENERGY STAR® requirements in your area.

GLASS		ENERGY		LIGHT	
		U-Factor How well a product prevents heat from escaping.	Solar Heat Gain Coefficient How well a product blocks heat caused by sunlight.	Visible Light Transmittance How much visible light comes through a product.	UV Protection How well a product blocks ultraviolet rays.
SmartSun™	Thermal control similar to tinted glass, with visible light transmittance similar to Low-E glass.	● ● ● ○	● ● ● ●	● ● ● ○	● ● ● ●
SmartSun with HeatLock® Technology	Applied to the room-side surface, it reflects heat back into the home and improves U-Factor values.	● ● ● ●	● ● ● ●	● ● ● ○	● ● ● ●
Low-E	Outstanding overall performance for climates where both heating and cooling costs are a concern.	● ● ● ○	● ● ● ○	● ● ● ○	● ● ● ○
Low-E with HeatLock Technology	Applied to the room-side surface, it reflects heat back into the home and improves U-Factor values.	● ● ● ●	● ● ● ○	● ● ● ○	● ● ● ○
Sun*	Outstanding thermal control in southern climates where less solar heat gain is desired.	● ● ● ○	● ● ● ●	● ○ ○ ○	● ● ● ○
PassiveSun®	Ideal for northern, passive solar construction applications where solar heat gain is desired.	● ● ● ○	● ○ ○ ○	● ● ● ●	● ● ○ ○
PassiveSun with HeatLock Technology	Applied to the room-side surface, it reflects heat back into the home and improves U-Factor values.	● ● ● ●	● ○ ○ ○	● ● ● ●	● ● ○ ○
Clear Dual-Pane	High visibility, with basic thermal performance.	● ○ ○ ○	○ ○ ○ ○	● ● ● ●	○ ○ ○ ○

Center of glass performance only. Ratings based on glass options as of July 2024. Visit andersenwindows.com/energystar for ENERGY STAR map and ENERGY STAR Most Efficient information. Contact your Andersen supplier for unit NFRC performance values.

HEATLOCK® TECHNOLOGY

Applied to the room-side glass surface, our HeatLock coating reflects heat back into the home for improved performance.

ADDITIONAL OPTIONS

Tempered safety glass is standard on patio doors and required for larger window sizes.

Patterned glass lets in light while obscuring vision and adds a unique, decorative touch.



Obscure Satin Etch

TRIPLE-PANE GLASS FOR GLIDING PATIO DOORS**

Three panes of glass combine with either argon gas blend or air, and low-E coatings to provide enhanced energy performance. Adding triple-pane glass to one of our gliding patio doors results in a lower U-Factor value than using dual-pane glass.

GLASS SPACER OPTIONS FOR PATIO DOORS

Choose black or stainless steel glass spacers to create a customized look for gliding or hinged patio doors. Black glass spacers blend in with the color of the door for a sleek design or serve as a shadow line.

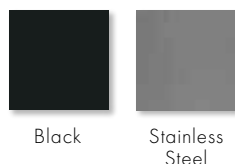

Black Stainless Steel

BLINDS-BETWEEN-THE-GLASS FOR GLIDING PATIO DOORS

Blinds-between-the-glass are located between the panes of insulated glass, protected from dust and damage, and never need cleaning. White blinds are available on select Perma-Shield® gliding patio doors.

TIME-SAVING FILM

We protect our products during delivery and construction with translucent film on the glass that peels away for a virtually spotless window.

Visit andersenwindows.com/glass for additional information.

*Sun glass available on 200 Series patio doors only.

**Triple-pane glass available on 200 Series gliding patio doors only.

“ENERGY STAR” is a registered trademark of the U.S. Environmental Protection Agency.

ANDERSEN® 200 SERIES WINDOWS



TILT-WASH DOUBLE-HUNG WINDOWS

Tilt-wash double-hung windows are available in our most popular sizes, and feature low-maintenance exteriors and real wood interiors. The tilt-wash design makes them easy to clean from inside the home. The tilt-wash transom and tilt-wash picture windows are available in matching sizes.



TILT-WASH HALF CIRCLE WINDOWS

Tilt-wash half circle windows are available to fit over tilt-wash double-hung windows.



GLIDING WINDOWS

Gliding windows feature low-maintenance exteriors and wood interiors. A single sash glides horizontally for full top-to-bottom ventilation, an excellent choice for rooms that face walkways, porches or decks because the sash doesn't open outward. Picture windows are available in matching sizes.

For more window options, visit andersenwindows.com/windows.

WINDOW HARDWARE

200 Series Tilt-Wash Double-Hung Windows



Lock & Keeper

Stone | **White**

Optional finishes:

Antique Brass | Black
Bright Brass | Oil Rubbed Bronze
Satin Nickel



Optional Classic Series™ Lift*

Stone | **White**

200 Series Gliding Windows



Lock & Keeper

Stone | **White**

Optional finishes:

Antique Brass
Black
Bright Brass
Oil Rubbed Bronze
Satin Nickel



Classic Series Pull

Stone | **White**

Stone finish is standard for pine interiors. White finish is standard for white interiors.
Bold name denotes finish shown.

HARDWARE FINISHES



Stone

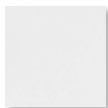

White



Antique
Brass



Black



Bright Brass



Oil Rubbed
Bronze**



Satin Nickel

*Hardware is sold separately.

**Oil rubbed bronze is a "living finish" that will change with time and use, see limited warranty for details.

Printing limitations prevent exact replication of finishes. See your Andersen supplier for actual finish samples.



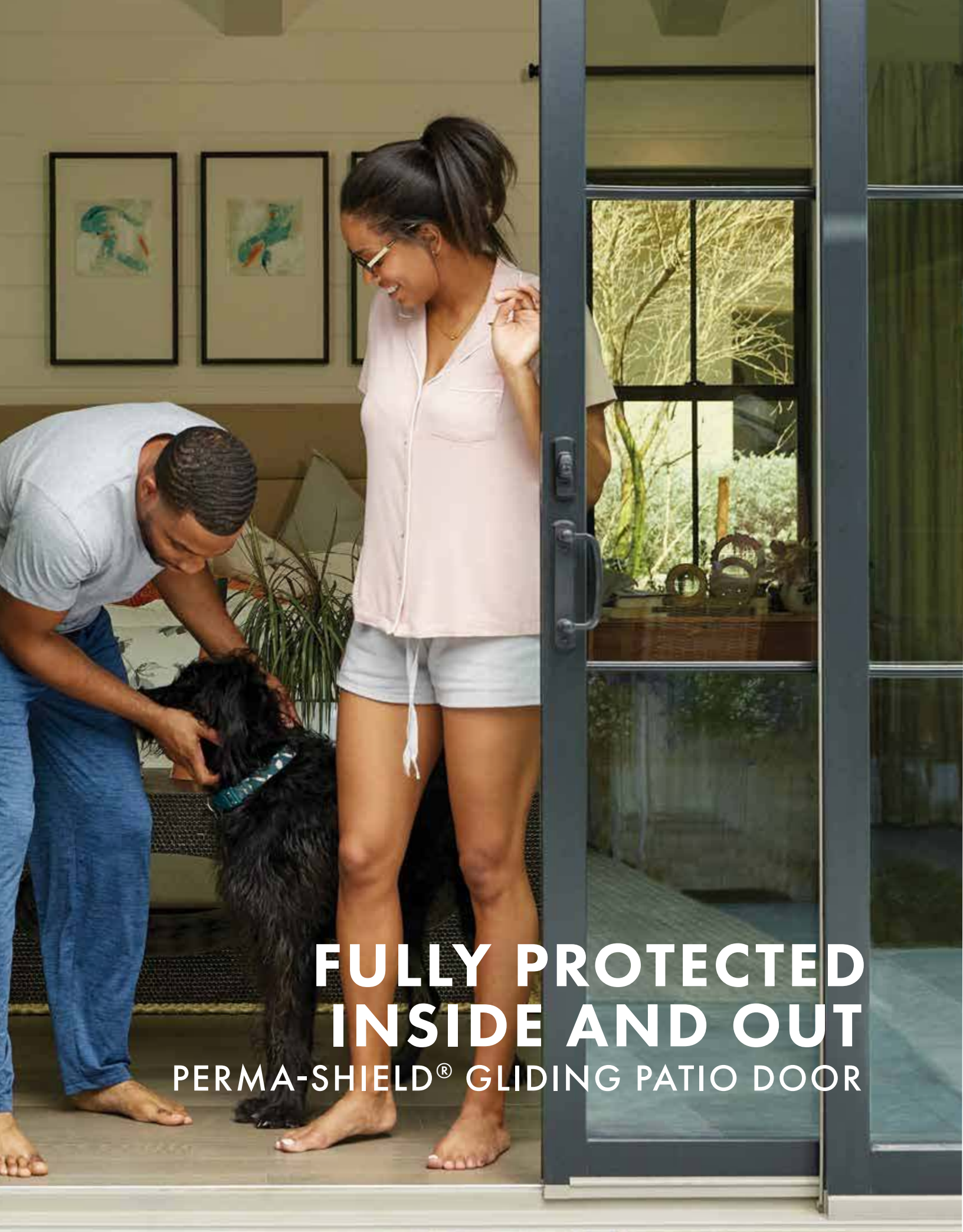

**FULLY PROTECTED
INSIDE AND OUT**
PERMA-SHIELD® GLIDING PATIO DOOR

ANDERSEN® 200 SERIES PATIO DOORS

NARROLINE® GLIDING PATIO DOORS

Narroline gliding patio doors combine the beauty of natural wood with sleek, contemporary profiles to maximize views. Choose from pine, maple or oak wood interior, or one of three painted interior options. They're available in two- and four-panel configurations, and in custom sizes.



PERMA-SHIELD® GLIDING PATIO DOORS

Perma-Shield gliding patio doors are protected inside and out with rigid vinyl cladding to give homes a contemporary look while keeping maintenance to a minimum. They're available in two-panel configurations and in custom sizes. Convenient blinds-between-the-glass are available on select sizes.

HINGED INSWING PATIO DOORS

Hinged inswing patio doors are built with fiberglass panel construction, traditional styling and white interiors, and are available in three exterior colors. Their hook deadbolt lock provides extra strength, a more weathertight seal and added security compared to ordinary deadbolt locks. They're available in one- and two-panel configurations.



ANDERSEN® PATIO DOOR HARDWARE*

Andersen offers Yuma®, Encino®, Newbury® and Anvers® patio door hardware options that feature solid drop-forged brass for added strength, while the Albany and Tribeca® hardware options are made of zinc die-cast with durable powder-coated finishes. Additional hardware options such as exterior keyed locks, matching hinge finishes and more are also available.



Bold name denotes finish shown.

HARDWARE FINISHES



*Hardware is sold separately.

**These finishes are "living finishes" that will change with time and use, see limited warranty for details.

Mix-and-match interior and exterior style and finish hardware options are available.

Bright brass and satin nickel finishes on patio door hardware are a PVD finish and feature a 10-year limited warranty.

Matching hinges available in most finishes for inswing patio doors.

Printing limitations prevent exact replication of finishes. See your Andersen supplier for actual finish samples.



**DESIGNER HARDWARE
FOR HINGED PATIO DOORS**
PAGES 12-13

DESIGNER HINGED DOOR HARDWARE*

Our designer hardware collections are carefully curated from today's leading hardware brands. They have a luxurious look and substantial feel, and can match perfectly with other hardware and accessories throughout the home. Available on Andersen® hinged patio doors, folding doors and entry doors.



All handle styles are available with an urban or traditional escutcheon plate, and in all hardware finishes.

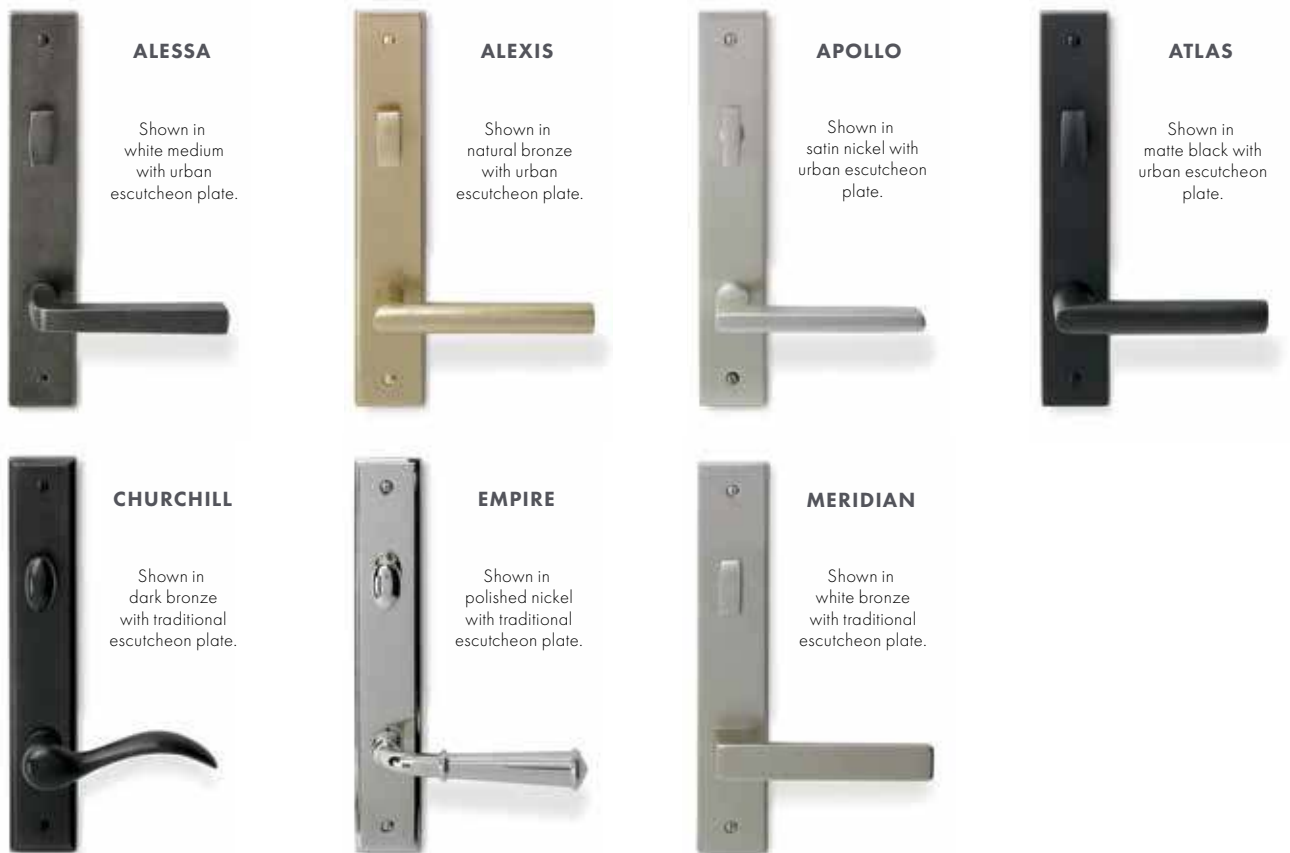

HARDWARE FINISHES

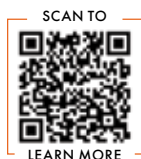

Explore all door hardware options at andersenwindows.com/doorhardware.

*Hardware is sold separately.
**These finishes are "living finishes" that will change with time and use, see limited warranty for details. Ashley Norton Inc. manufactures and supports the limited warranty for Ashley Norton hardware. Printing limitations prevent exact replication of finishes. See your Andersen supplier for actual finish samples.

BALDWIN **NEW!**

All styles are available in all hardware finishes.



L021

Shown in satin nickel.



L023

Shown in satin black.



5162

Shown in satin black.



5173

Shown in satin brass.



5455V

Shown in oil rubbed bronze.



5485V

Shown in non-lacquered brass.

HARDWARE FINISHES



Non-Lacquered Brass**



Oil Rubbed Bronze**



Satin Black



Satin Brass



Satin Nickel

FSB®



1035

Black Anodized Aluminum
Satin Stainless Steel



1075

Black Anodized Aluminum
Satin Stainless Steel



1076

Black Anodized Aluminum
Satin Stainless Steel



1102

Satin Stainless Steel

HARDWARE FINISHES



Black Anodized Aluminum



Satin Stainless Steel

Bold name denotes finish shown.

*Hardware is sold separately.

**These finishes are "living finishes" that will change with time and use, see limited warranty for details. Baldwin Hardware manufactures and supports the limited warranty for Baldwin Estate hardware.

All trademarks where denoted are marks of their respective owners. Printing limitations prevent exact replication of finishes. See your Andersen supplier for actual finish samples.

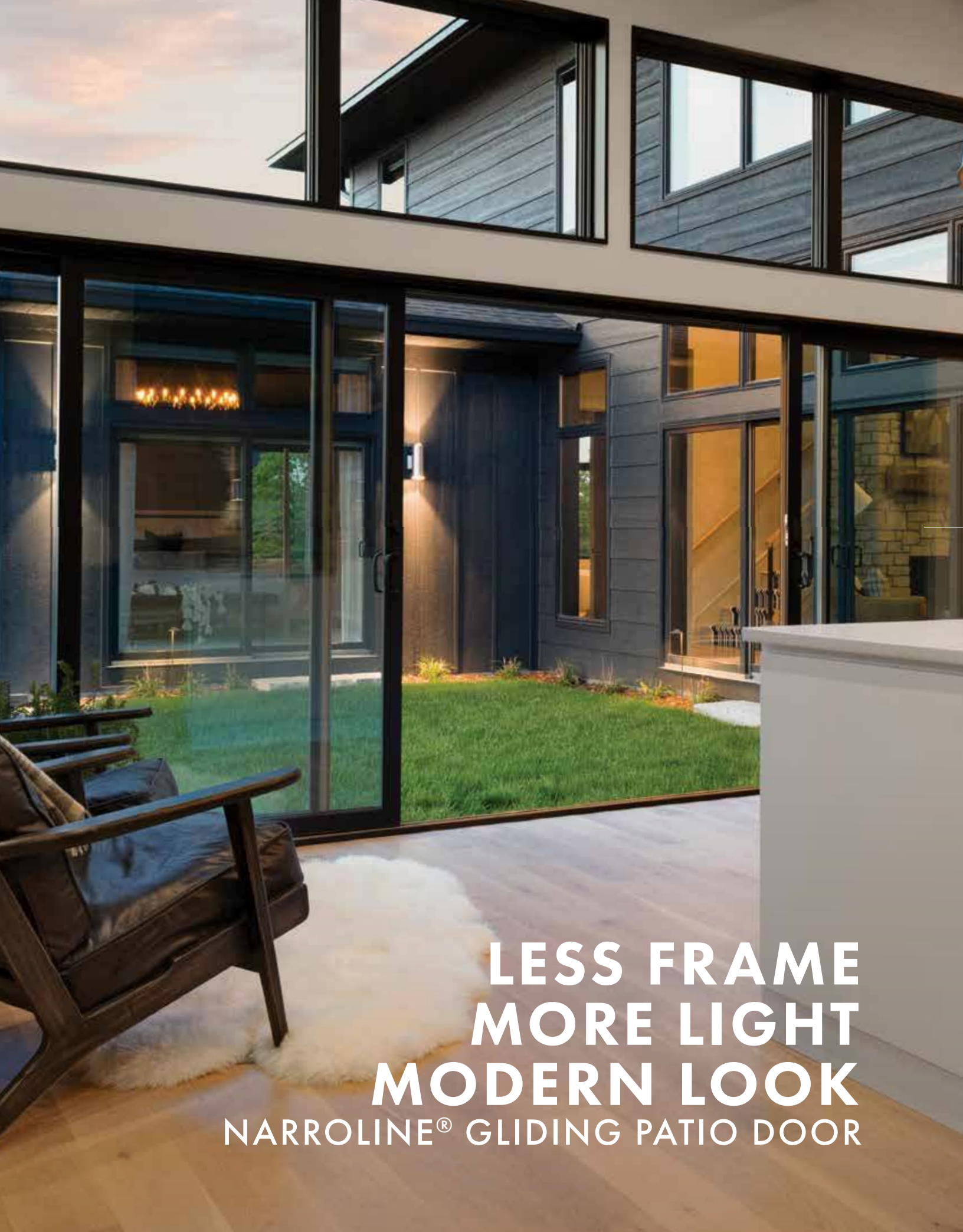

**LESS FRAME
MORE LIGHT
MODERN LOOK**

NARROLINE® GLIDING PATIO DOOR

GRILLES

Grilles are available in a variety of widths, configurations, and patterns to fit any architectural style or project need.

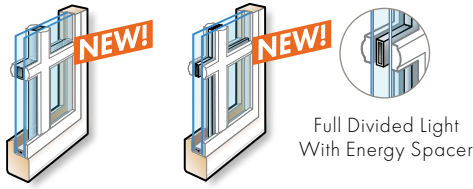

Full Divided Light With Energy Spacer

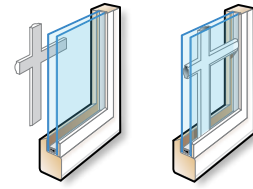
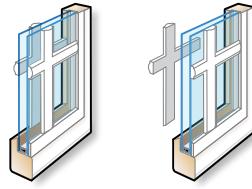

Full Divided Light Options

Permanent grilles on the interior and exterior with a spacer between the glass (left). For improved thermal performance, choose full divided light with an energy spacer (right) — a 3 mm gap around a narrow spacer minimizes the transfer of heat and cold to the interior glass.

Simulated Divided Light Options

Permanent grilles on the exterior and interior with no spacer between the glass (left). We also offer permanent exterior grilles with removable interior grilles (right) available in natural wood or prefinished white.

Convenient Cleaning Options

Removable interior grilles come off for easy cleaning (left). Andersen® Finelight™ grilles-between-the-glass* (right) are installed between the glass panes and feature a contoured 3/4" (19) profile.

Grille Patterns**

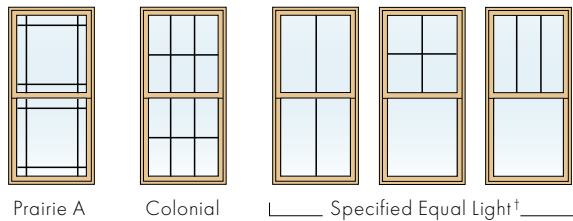

Prairie A

Colonial

Specified Equal Light†

Grille Bar Widths

Actual width shown.

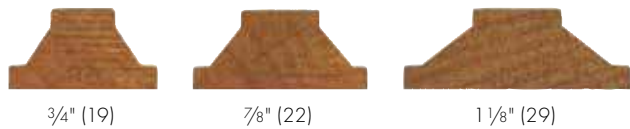

3/4" (19)

7/8" (22)

1 1/8" (29)

INSECT SCREENS

TruScene® and conventional insect screens are available for double-hung and gliding windows. For patio doors, conventional screens are available in the configurations shown below.

Windows



Full insect screen for double-hung and gliding windows. Half insect screen for lower sash of double-hung windows.

Gliding Patio Doors



Premium retractable screen for two- and four-panel doors.

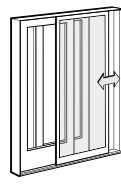

Gliding screen for two- and four-panel doors.

Hinged Inswing Patio Doors

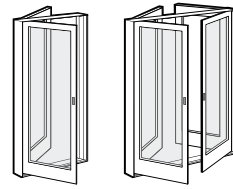

Hinged screen for single-panel doors. Double-hinged screens for two-panel doors when both panels open.

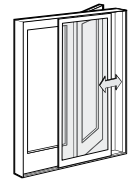

Gliding screen for two-panel doors when only one panel opens.

*7/8" (22) and 1 1/8" (29) are not available in Finelight grilles-between-the-glass.

**For all standard patterns available for a specific window or door, refer to the detailed product sections in this product guide or contact your Andersen supplier.

†Specify number of same-size rectangles across or down. Dimensions in parentheses are in millimeters.

COMPARISON CHART

Use the quick reference chart below to decide which Andersen® products best fit your project needs.

		200 SERIES WINDOWS		200 SERIES PATIO DOORS		
FEATURES		Tilt-Wash Double-Hung	Gliding	Narroline® Gliding	Perma-Shield® Gliding	Hinged Inswing
Low-Maintenance Exteriors						
	White	•	•	•	•	•
	Canvas			•	•	
	Sandtone	•	•	•	•	•
	Terratone			•	•	•
	Dark Bronze			•	•	
	Black			•	•	
Interiors						
	Pine	•	•	•		
	Maple			•		
	Oak			•		
	White	•	•	•		•
	Dark Bronze			•		
	Black			•		
	Same as Exterior				•	
Easy Cleaning						
	Tilt-to-Clean Sash	•				
Dual-Pane Glass Additional dual-pane glass options are available. See page 5 for details. Glass options for doors are tempered.						
	Low-E	•	•	•	•	•
	Low-E SmartSun™	•	•	•	•	•
	Low-E Sun			•	•	•
	Clear Dual-Pane	•	•	•	•	•
	HeatLock® Technology	•	•	•	•	•
Triple-Pane Glass See patio door product sections for triple-pane glass options. Glass options for doors are tempered.						
	Triple-Pane Glass			•	•	
Glass Spacers						
	Black			•	•	•
	Stainless Steel	•	•	•	•	•
Grilles & Blinds						
	Full Divided Light	•	•	•	•	•
	Full Divided Light With Energy Spacer	•	•	•	•	•
	Simulated Divided Light	•	•	•	•	•
	Removable Interior Grilles	•	•	•	•	•
	Finelight™ Grilles-Between-the-Glass	•	•	•	•	•
	Blinds-Between-the-Glass				•	
Performance Option						
	Performance Grade (PG) Upgrade				•	
Standard Sizes						
	Minimum Width	1'-7 1/2" (495)	2'-11 1/2" (902)	4'-11 1/4" (1505)	4'-11 1/4" (1505)	2'-6 1/8" (765)
	Maximum Width	3'-3 1/2" (1003)	5'-11 1/2" (1816)	15'-9" (4801)	8'-0" (2438)	5'-11 1/4" (1810)
	Minimum Height	2'-11 1/2" (902)	1'-5 1/2" (445)	6'-7 1/2" (2019)	6'-7 1/2" (2019)	6'-7 1/2" (2019)
	Maximum Height	5'-11 1/2" (1816)	4'-11 1/2" (1511)	7'-11 1/2" (2426)	7'-11 1/2" (2426)	7'-11 1/2" (2426)
Custom Sizes						
				•	•	



TILT-WASH DOUBLE-HUNG WINDOWS

Tables of Sizes	19-20
Specifications	20-21
Grille Patterns	21
Window Details	22
Joining Details	22
Combination Designs	57
Product Performance	65

TILT-WASH DOUBLE-HUNG WINDOWS

FEATURES

FRAME

A Exterior frame members are treated with water-repellent preservative and covered with a Perma-Shield® rigid vinyl cladding that maintains an attractive appearance while minimizing maintenance.

B Interior surfaces are unfinished pine. Low-maintenance prefinished white interiors are available.

C A full-perimeter installation flange makes installation easy and fast with little or no adjustment. It's fixed, seamless and integrated with the exterior frame.

D Flexible weatherstrip around all four sides is factory installed, and provides a tight seal between the sash and frame.

SASH

An in-sash balancer minimizes the view of the jamb liner, maximizing the amount of wood in the frame. The window can be secured through the side jambs to stud walls without hitting the balancer.

E A polyester stabilized coat with a Flexacron® finish is electrostatically applied to penetrate all exterior surfaces for maximum protection and a lustrous finish.

F Wood sash members are treated with a water-repellent wood preservative for long-lasting protection and performance.

G Sash interior surfaces are unfinished pine. Prefinished white interiors are also available.

The convenient tilt-wash design makes it easy to clean the window from the inside.



CAUTION: Painting and staining may cause damage to rigid vinyl. Andersen does not warrant the adhesion or performance of homeowner-applied paint over vinyl or other factory-coated surfaces. For vinyl painting instructions and preparation, contact your Andersen supplier. Do not paint weatherstrip. Creosote-based stains should not come in contact with Andersen products. Abrasive cleaners or solutions containing corrosive solvents should not be used on Andersen products.

*Visit andersenwindows.com/warranty for details.

**Hardware is sold separately.

†Oil rubbed bronze is a "living finish" that will change with time and use, see limited warranty for details.

††TruScene insect screens let in over 25% more fresh air than standard Andersen fiberglass insect screens.

"Flexacron" is a registered trademark of PPG Industries, Inc.

Naturally occurring variations in grain, color and texture of wood make each window one of a kind. All wood interiors are unfinished unless a finish is specified.

Printing limitations prevent exact replication of colors and finishes. See your Andersen supplier for actual color and finish samples.

Dimensions in parentheses are in millimeters.

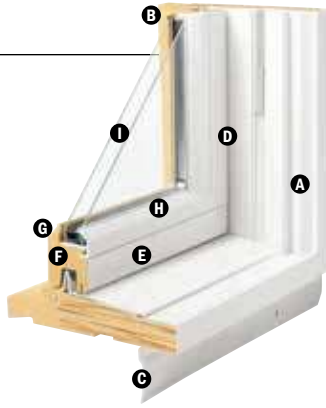

TWO-TONE OPTION

Available with a two-tone color configuration, featuring a prefinished white interior and a Sandtone exterior. Some exterior components are visible from the interior. Corresponding picture and transom windows, as well as grilles, are available to match.

GLASS

H A rigid vinyl glazing bead combined with a high-grade silicone glazing bed keep the glass bonded firmly to the sash, and help minimize water and air infiltration.

I Glass options include:

- Low-E glass
- Low-E HeatLock® glass
- Low-E SmartSun™ glass
- Low-E SmartSun HeatLock glass
- Clear dual-pane glass

Tempered and other glass options are available. Contact your Andersen supplier.

A removable translucent film helps shield the glass from damage during delivery and construction, and simplifies finishing at the job site.

EXTERIORS & INTERIORS

EXTERIOR COLORS



INTERIOR OPTIONS



HARDWARE



Lock & Keeper

Stone | **White**



Optional Classic Series™ Lift**

Stone | **White**

Optional finishes:**
Antique Brass | Black | Bright Brass
Oil Rubbed Bronze | Satin Nickel

Stone finish is standard for pine interiors, and white finish is standard for white interiors. Bold name denotes finish shown.

HARDWARE FINISHES



Stone

White

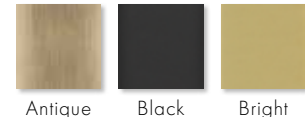

Antique Brass

Black

Bright Brass

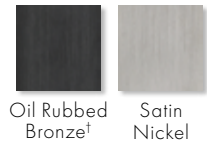

Oil Rubbed Bronze†

Satin Nickel

ACCESSORIES Sold Separately

FRAME

Extension Jambs

Standard jamb depth is 3 1/4" (83). Extension jambs are available in unfinished pine or prefinished white. Some sizes may be veneered. Factory-applied and non-applied interior extension jambs are available in 1/16" (1.5) increments between 4 9/16" (114) and 7 1/8" (181). Extension jambs can be factory applied to either three sides (stool and apron) or four sides (picture frame casing).

Drywall Return

Available with a 3" (76) jamb depth with a flat interior surface for easy drywall return application. Available in unfinished pine or prefinished white.

HARDWARE

Window Opening Control Device

A recessed window opening control device is available factory applied. It limits the sash travel to less than 4" (102) when the window is first opened. Available in stone or white. A field-applied window opening control device is also available.



INSECT SCREENS

Choose full insect screen or half insect screen. Half insect screen allows ventilation without affecting the view through the upper sash. Frames are available in colors to match product exteriors.

TruScene® Insect Screens

Our TruScene insect screens let in over 25% more fresh air†† and provide 50% greater clarity than conventional Andersen® insect screens, all while keeping out unwanted small insects.

Conventional Insect Screens

Conventional insect screens have charcoal gray powder-coated aluminum screen mesh.

GRILLES

Grilles are available in a variety of configurations and widths. See page 15 for details.

EXTERIOR TRIM

Available with Andersen exterior trim. See the Exterior Trim section starting on page 51.

Table of Tilt-Wash Double-Hung and Transom Window Sizes

Scale 1/8" (3) = 1'-0" (305) – 1:96

Window Dimension	1'-7 1/2"	1'-11 1/2"	2'-3 1/2"	2'-7 1/2"	2'-11 1/2"	3'-3 1/2"
	(495)	(597)	(699)	(800)	(902)	(1003)
Minimum Rough Opening	1'-8"	2'-0"	2'-4"	2'-8"	3'-0"	3'-4"
	(508)	(610)	(711)	(813)	(914)	(1016)
Unobstructed Glass (lower sash only)	13 1/2"	17 1/2"	21 1/2"	25 1/2"	29 1/2"	33 1/2"
	(343)	(445)	(546)	(648)	(749)	(851)

See Half Circle chart	244CT18	244CT20	244CT24	244CT28	244CT30	244CT34
11-1/2" (292)	244FX1810	244FX2010	244FX2410	244FX2810	244FX3010	244FX3410
1'-5 1/2" (445)	244FX1816	244FX2016	244FX2416	244FX2816	244FX3016	244FX3416
1'-11 1/2" (597)	244FX1820	244FX2020	244FX2420	244FX2820	244FX3020	244FX3420
2'-11 1/2" (902)	244DH1830	244DH2030	244DH2430	244DH2830	244DH3030	244DH3430
3'-5 1/2" (1054)	244DH1836	244DH2036	244DH2436	244DH2836	244DH3036	244DH3436
3'-11 1/2" (1207)	244DH1840	244DH2040	244DH2440	244DH2840	244DH3040	244DH3440
4'-5 1/2" (1359)	244DH1846	244DH2046	244DH2446	244DH2846	244DH3046	244DH3446
4'-8 1/2" (1435)	244DH1849	244DH2049	244DH2449	244DH2849	244DH3049 ^Ø	244DH3449 ^Ø
4'-11 1/2" (1511)	244DH1850	244DH2050	244DH2450	244DH2850	244DH3050 ^Ø	244DH3450 ^Ø
5'-5 1/2" (1664)	244DH1856	244DH2056	244DH2456	244DH2856 ^Ø	244DH3056 ^Ø	244DH3456 ^Ø
5'-11 1/2" (1816)	244DH1860	244DH2060	244DH2460	244DH2860 ^Ø	244DH3060 ^Ø	244DH3460 ^Ø

Table of Tilt-Wash Half Circle Window Sizes

Scale 1/8" (3) = 1'-0" (305) – 1:96

Window Dimension	1'-7 1/2"	1'-11 1/2"
	(495)	(597)
Minimum Rough Opening	1'-8"	2'-0"
	(508)	(610)
Unobstructed Glass	13 1/2"	17 1/2"
	(343)	(445)

Window Dimension	2'-3 1/2"	2'-7 1/2"
	(699)	(800)
	2'-4"	2'-8"
	(711)	(813)
	21 1/2"	25 1/2"
	(546)	(648)

Window Dimension	2'-11 1/2"	3'-3 1/2"
	(902)	(1003)
	3'-0"	3'-4"
	(914)	(1016)
	29 1/2"	33 1/2"
	(749)	(851)

Window Dimension	1'-0 5/8"	1'-2 5/8"	1'-4 5/8"	1'-6 5/8"	1'-8 5/8"
	(321)	(371)	(422)	(473)	(524)
	1'-1 1/8"	1'-3 1/8"	1'-5 1/8"	1'-7 1/8"	1'-9 1/8"
	(333)	(384)	(435)	(486)	(537)
	6 5/8"	8 5/8"	10 5/8"	12 5/8"	14 5/8"
	(168)	(219)	(270)	(321)	(371)

Grille patterns shown on page 21.

Details shown on page 22.

• Window Dimension always refers to outside frame-to-frame dimension.
 • **Minimum Rough Opening dimensions may need to be increased to allow for use of building wraps, flashing, sill panning, brackets, fasteners or other items. See page 74 for more details.**
 • Dimensions in parentheses are in millimeters.
 ØMeets or exceeds clear opening area of 5.7 sq. ft. or 0.53 m², clear opening width of 20" (508) and clear opening height of 24" (610). See table on page 21.

TILT-WASH DOUBLE-HUNG WINDOWS

Table of Tilt-Wash Picture Window Sizes

Scale 1/8" (3) = 1'-0" (305) – 1:96

Window Dimension	2'-11 1/2" (902)	3'-11 1/2" (1207)	4'-5 1/2" (1359)	4'-8 1/2" (1435)	4'-11 1/2" (1511)	5'-5 1/2" (1663)	5'-11 1/2" (1816)
Minimum Rough Opening	3'-0" (914)	4'-0" (1219)	4'-6" (1372)	4'-9" (1448)	5'-0" (1524)	5'-6" (1676)	6'-0" (1829)
Unobstructed Glass	29 1/2" (749)	41 1/2" (1054)	47 1/2" (1207)	50 1/2" (1283)	53 1/2" (1359)	59 1/2" (1511)	65 1/2" (1664)
2'-11 1/2" (902)							
3'-11 1/2" (1207)							
4'-5 1/2" (1359)							
4'-8 1/2" (1435)							
4'-11 1/2" (1511)							
5'-5 1/2" (1664)							
5'-11 1/2" (1816)							

Grille patterns shown on page 21. Details shown on page 22.

- Window Dimension always refers to outside frame-to-frame dimension.
- **Minimum Rough Opening dimensions may need to be increased to allow for use of building wraps, flashing, sill panning, brackets, fasteners or other items. See page 74 for more details.**
- Dimensions in parentheses are in millimeters.

Tilt-Wash Picture Window Area Specifications

Window Number	Glass Area Sq. Ft./ (m ²)	Overall Window Area Sq. Ft./ (m ²)	Window Number	Glass Area Sq. Ft./ (m ²)	Overall Window Area Sq. Ft./ (m ²)	Window Number	Glass Area Sq. Ft./ (m ²)	Overall Window Area Sq. Ft./ (m ²)
244FX3030	6.04 (0.56)	8.75 (0.81)	244FX4640	13.69 (1.27)	17.65 (1.64)	244FX5046	17.65 (1.64)	22.11 (2.05)
244FX3040	8.50 (0.79)	11.71 (1.09)	244FX4646	15.67 (1.46)	19.88 (1.85)	244FX5049	18.76 (1.74)	23.35 (2.17)
244FX3046	9.73 (0.90)	13.19 (1.23)	244FX4649	16.66 (1.55)	21.00 (1.95)	244FX5050	19.88 (1.85)	24.59 (2.28)
244FX3049	10.35 (0.96)	13.93 (1.29)	244FX4650	17.65 (1.64)	22.11 (2.05)	244FX5056	22.11 (2.05)	27.06 (2.51)
244FX3050	10.96 (1.02)	14.67 (1.36)	244FX4656	19.63 (1.82)	24.34 (2.26)	244FX5060	24.34 (2.26)	29.54 (2.75)
244FX3056	12.19 (1.13)	16.15 (1.50)	244FX4660	21.61 (2.01)	26.56 (2.47)	244FX5630	12.19 (1.13)	16.15 (1.50)
244FX3060	13.42 (1.25)	17.63 (1.64)	244FX4930	10.35 (0.96)	13.93 (1.29)	244FX5640	17.15 (1.59)	21.61 (2.01)
244FX4030	8.50 (0.79)	11.71 (1.09)	244FX4940	14.55 (1.35)	18.64 (1.73)	244FX5646	19.63 (1.82)	24.34 (2.26)
244FX4040	11.96 (1.11)	15.67 (1.46)	244FX4946	16.66 (1.55)	21.00 (1.95)	244FX5649	20.87 (1.94)	25.70 (2.39)
244FX4046	13.69 (1.27)	17.65 (1.64)	244FX4949	17.71 (1.65)	22.17 (2.06)	244FX5650	22.11 (2.05)	27.06 (2.51)
244FX4049	14.55 (1.35)	18.64 (1.73)	244FX4950	18.76 (1.74)	23.35 (2.17)	244FX6030	13.42 (1.25)	17.63 (1.64)
244FX4050	15.42 (1.43)	19.63 (1.82)	244FX4956	20.87 (1.94)	25.70 (2.39)	244FX6040	18.88 (1.75)	23.59 (2.19)
244FX4056	17.15 (1.59)	21.61 (2.01)	244FX4960	22.97 (2.13)	28.05 (2.61)	244FX6046	21.61 (2.01)	26.56 (2.47)
244FX4060	18.88 (1.75)	23.59 (2.19)	244FX5030	10.96 (1.02)	14.67 (1.36)	244FX6049	22.97 (2.13)	28.05 (2.61)
244FX4630	9.73 (0.90)	13.19 (1.23)	244FX5040	15.42 (1.43)	19.63 (1.82)	244FX6050	24.34 (2.26)	29.54 (2.75)

• Dimensions in parentheses are in square meters.

Tilt-Wash Double-Hung Window Opening and Area Specifications

Window Number	Clear Opening Area		Clear Opening in Full Open Position		Glass Area Sq. Ft./ (m ²)	Vent Area Sq. Ft./ (m ²)	Top of Subfloor to Top of Inside Sill Stop Inches/(mm)	Overall Window Area Sq. Ft./ (m ²)
	Sq. Ft./ (m ²)		Width Inches/(mm)	Height Inches/(mm)				
244DH1830	1.72	(0.16)	16 9/16" (421)	14 15/16" (380)	2.56 (0.24)	1.72 (0.16)	48 9/16" (1233)	4.81 (0.45)
244DH1836	2.06	(0.19)	16 9/16" (421)	17 15/16" (456)	3.12 (0.29)	2.06 (0.19)	42 9/16" (1081)	5.62 (0.52)
244DH1840	2.41	(0.22)	16 9/16" (421)	20 15/16" (532)	3.69 (0.34)	2.41 (0.22)	36 9/16" (929)	6.43 (0.60)
244DH1846	2.75	(0.26)	16 9/16" (421)	23 15/16" (608)	4.25 (0.40)	2.75 (0.26)	30 9/16" (776)	7.24 (0.67)
244DH1849	2.93	(0.27)	16 9/16" (421)	25 7/16" (647)	4.53 (0.42)	2.93 (0.27)	27 9/16" (700)	7.65 (0.71)
244DH1850	3.10	(0.29)	16 9/16" (421)	26 15/16" (685)	4.81 (0.45)	3.10 (0.29)	24 9/16" (624)	8.06 (0.75)
244DH1856	3.44	(0.32)	16 9/16" (421)	29 15/16" (761)	5.37 (0.45)	3.44 (0.32)	18 9/16" (471)	8.87 (0.82)
244DH1860	3.79	(0.35)	16 9/16" (421)	32 15/16" (837)	5.94 (0.55)	3.79 (0.35)	12 9/16" (319)	9.68 (0.90)
244DH2030	2.14	(0.20)	20 9/16" (522)	14 15/16" (380)	3.32 (0.31)	2.14 (0.20)	48 9/16" (1233)	5.79 (0.54)
244DH2036	2.56	(0.24)	20 9/16" (522)	17 15/16" (456)	4.05 (0.38)	2.56 (0.24)	42 9/16" (1081)	6.77 (0.63)
244DH2040	2.99	(0.28)	20 9/16" (522)	20 15/16" (532)	4.78 (0.44)	2.99 (0.28)	36 9/16" (929)	7.75 (0.72)
244DH2046	3.42	(0.32)	20 9/16" (522)	23 15/16" (608)	5.51 (0.51)	3.42 (0.32)	30 9/16" (776)	8.73 (0.81)
244DH2049	3.63	(0.34)	20 9/16" (522)	25 7/16" (647)	5.88 (0.55)	3.63 (0.34)	27 9/16" (700)	9.22 (0.86)
244DH2050	3.85	(0.36)	20 9/16" (522)	26 15/16" (685)	6.24 (0.58)	3.85 (0.36)	24 9/16" (624)	9.71 (0.90)
244DH2056	4.28	(0.40)	20 9/16" (522)	29 15/16" (761)	6.97 (0.65)	4.28 (0.40)	18 9/16" (471)	10.69 (0.99)
244DH2060	4.71	(0.44)	20 9/16" (522)	32 15/16" (837)	7.70 (0.72)	4.71 (0.44)	12 9/16" (319)	11.67 (1.08)
244DH2430	2.55	(0.24)	24 9/16" (624)	14 15/16" (380)	4.08 (0.38)	2.55 (0.24)	48 9/16" (1233)	6.78 (0.63)
244DH2436	3.06	(0.28)	24 9/16" (624)	17 15/16" (456)	4.98 (0.46)	3.06 (0.28)	42 9/16" (1081)	7.93 (0.74)
244DH2440	3.57	(0.33)	24 9/16" (624)	20 15/16" (532)	5.88 (0.55)	3.57 (0.33)	36 9/16" (929)	9.07 (0.84)
244DH2446	4.09	(0.38)	24 9/16" (624)	23 15/16" (608)	6.77 (0.63)	4.09 (0.38)	30 9/16" (776)	10.22 (0.95)
244DH2449	4.34	(0.40)	24 9/16" (624)	25 7/16" (647)	7.22 (0.67)	4.34 (0.40)	27 9/16" (700)	10.79 (1.00)
244DH2450	4.60	(0.43)	24 9/16" (624)	26 15/16" (685)	7.67 (0.71)	4.60 (0.43)	24 9/16" (624)	11.36 (1.06)
244DH2456	5.11	(0.48)	24 9/16" (624)	29 15/16" (761)	8.56 (0.80)	5.11 (0.48)	18 9/16" (471)	12.51 (1.16)
244DH2460	5.62	(0.52)	24 9/16" (624)	32 15/16" (837)	9.46 (0.88)	5.62 (0.52)	12 9/16" (319)	13.65 (1.27)
244DH2830	2.97	(0.28)	28 9/16" (725)	14 15/16" (380)	4.84 (0.45)	2.97 (0.28)	48 9/16" (1233)	7.77 (0.72)
244DH2836	3.56	(0.33)	28 9/16" (725)	17 15/16" (456)	5.91 (0.55)	3.56 (0.33)	42 9/16" (1081)	9.08 (0.91)
244DH2840	4.16	(0.39)	28 9/16" (725)	20 15/16" (532)	6.97 (0.65)	4.16 (0.39)	36 9/16" (929)	10.39 (0.97)
244DH2846	4.75	(0.44)	28 9/16" (725)	23 15/16" (608)	8.03 (0.75)	4.75 (0.44)	30 9/16" (776)	11.70 (1.09)
244DH2849	5.05	(0.47)	28 9/16" (725)	25 7/16" (647)	8.56 (0.80)	5.05 (0.47)	27 9/16" (700)	12.36 (1.15)
244DH2850	5.35	(0.50)	28 9/16" (725)	26 15/16" (685)	9.09 (0.84)	5.35 (0.50)	24 9/16" (624)	13.02 (1.21)
244DH2856 ◊	5.94	(0.55)	28 9/16" (725)	29 15/16" (761)	10.16 (0.94)	5.94 (0.55)	18 9/16" (471)	14.33 (1.33)
244DH2860 ◊	6.54	(0.61)	28 9/16" (725)	32 15/16" (837)	11.22 (1.04)	6.54 (0.61)	12 9/16" (319)	15.64 (1.45)
244DH3030	3.38	(0.31)	32 9/16" (827)	14 15/16" (380)	5.60 (0.52)	3.38 (0.31)	48 9/16" (1233)	8.75 (0.81)
244DH3036	4.06	(0.38)	32 9/16" (827)	17 15/16" (456)	6.83 (0.64)	4.06 (0.38)	42 9/16" (1081)	10.23 (0.95)
244DH3040	4.74	(0.44)	32 9/16" (827)	20 15/16" (532)	8.06 (0.75)	4.74 (0.44)	36 9/16" (929)	11.71 (1.09)
244DH3046	5.42	(0.50)	32 9/16" (827)	23 15/16" (608)	9.29 (0.86)	5.42 (0.50)	30 9/16" (776)	13.19 (1.23)
244DH3049 ◊	5.76	(0.54)	32 9/16" (827)	25 7/16" (647)	9.91 (0.92)	5.76 (0.54)	27 9/16" (700)	13.93 (1.29)
244DH3050 ◊	6.09	(0.57)	32 9/16" (827)	26 15/16" (685)	10.52 (0.98)	6.09 (0.57)	24 9/16" (624)	14.67 (1.36)
244DH3056 ◊	6.77	(0.63)	32 9/16" (827)	29 15/16" (761)	11.75 (1.09)	6.77 (0.63)	18 9/16" (471)	16.15 (1.50)
244DH3060 ◊	7.45	(0.69)	32 9/16" (827)	32 15/16" (837)	12.98 (1.21)	7.45 (0.69)	12 9/16" (319)	17.63 (1.64)
244DH3430	3.80	(0.35)	36 9/16" (929)	14 15/16" (380)	6.36 (0.59)	3.80 (0.35)	48 9/16" (1233)	9.74 (0.91)
244DH3436	4.56	(0.42)	36 9/16" (929)	17 15/16" (456)	7.76 (0.72)	4.56 (0.42)	42 9/16" (1081)	11.38 (1.06)
244DH3440	5.32	(0.49)	36 9/16" (929)	20 15/16" (532)	9.16 (0.85)	5.32 (0.49)	36 9/16" (929)	13.03 (1.21)
244DH3446	6.08	(0.57)	36 9/16" (929)	23 15/16" (608)	10.55 (0.98)	6.08 (0.57)	30 9/16" (776)	14.68 (1.36)
244DH3449 ◊	6.46	(0.60)	36 9/16" (929)	25 7/16" (647)	11.25 (1.05)	6.46 (0.60)	27 9/16" (700)	15.50 (1.44)
244DH3450 ◊	6.84	(0.64)	36 9/16" (929)	26 15/16" (685)	11.95 (1.11)	6.84 (0.64)	24 9/16" (624)	16.32 (1.52)
244DH3456 ◊	7.61	(0.71)	36 9/16" (929)	29 15/16" (761)	13.34 (1.24)	7.61 (0.71)	18 9/16" (471)	17.97 (1.67)
244DH3460 ◊	8.37	(0.78)	36 9/16" (929)	32 15/16" (837)	14.74 (1.37)	8.37 (0.78)	12 9/16" (319)	19.61 (1.82)

Tilt-Wash Transom Window Specifications

Window Number	Glass Area Sq. Ft./ (m ²)	Overall Window Area Sq. Ft./ (m ²)
244FX1810	0.52 (0.05)	1.56 (0.15)
244FX1816	1.08 (0.10)	2.37 (0.22)
244FX1820	1.64 (0.15)	3.18 (0.30)
244FX2010	0.67 (0.06)	1.88 (0.17)
244FX2016	1.40 (0.13)	2.86 (0.27)
244FX2020	2.13 (0.20)	3.84 (0.36)
244FX2410	0.82 (0.08)	2.20 (0.20)
244FX2416	1.72 (0.16)	3.34 (0.31)
244FX2420	2.61 (0.24)	4.49 (0.42)
244FX2810	0.97 (0.09)	2.52 (0.23)
244FX2816	2.04 (0.19)	3.83 (0.36)
244FX2820	3.10 (0.29)	5.14 (0.48)
244FX3010	1.13 (0.11)	2.84 (0.26)
244FX3016	2.36 (0.22)	4.31 (0.40)
244FX3020	3.59 (0.33)	5.79 (0.54)
244FX3410	1.28 (0.12)	3.15 (0.29)
244FX3416	2.68 (0.25)	4.80 (0.45)
244FX3420	4.07 (0.38)	6.45 (0.60)

* Dimensions in parentheses are in square meters.

Tilt-Wash Half Circle Area Specifications

Window Number	Glass Area Sq. Ft./ (m ²)	Overall Window Area Sq. Ft./ (m ²)
244CT18	0.50 (0.05)	1.43 (0.13)
244CT20	0.84 (0.08)	1.98 (0.18)
244CT24	1.26 (0.12)	2.61 (0.24)
244CT28	1.77 (0.16)	3.33 (0.31)
244CT30	2.37 (0.22)	4.15 (0.39)
244CT34	3.06 (0.28)	5.04 (0.47)

* Dimensions in parentheses are in square meters.

* Top of Subfloor to Top of Inside Sill Stop is calculated based upon a structural header height of 6'-10 1/2" (2096).
 * Dimensions in parentheses are in millimeters or square meters.
 ◊ Meets or exceeds clear opening area of 5.7 sq. ft. or 0.53 m², clear opening width of 20" (508) and clear opening height of 24" (610).

Grille Patterns

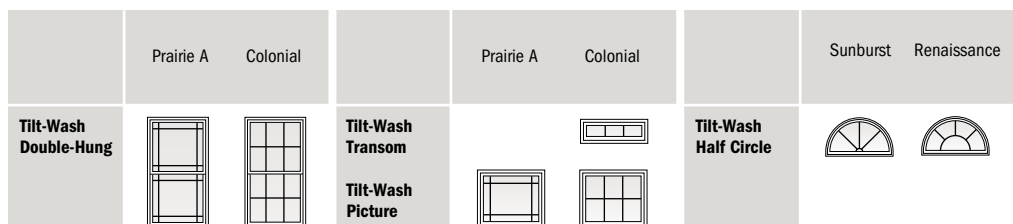

Patterns are available for all units also in upper sash only (USO). Specified equal light and custom patterns are also available.

For more grille options, see page 15 or visit andersenwindows.com/grilles.

Number of lights and overall pattern varies with window size. Patterns may not be available in all configurations or sizes.

Additional picture window patterns are available, contact your Andersen supplier.

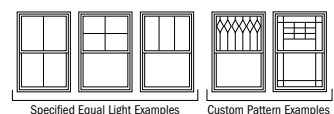

TILT-WASH DOUBLE-HUNG WINDOWS

Tilt-Wash Double-Hung Window Details

Scale 1 1/2" (38) = 1'-0" (305) – 1:8

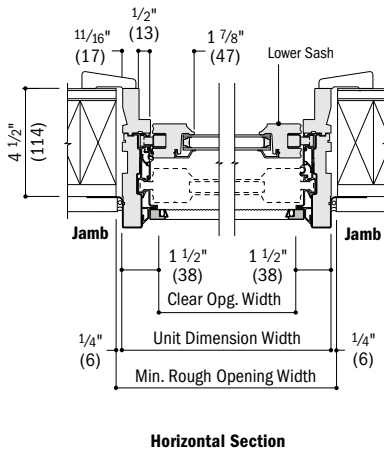
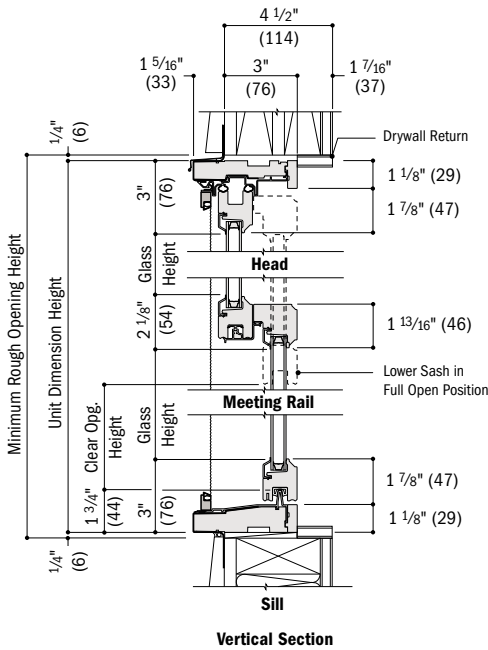

Tilt-Wash Half Circle Window Detail

Scale 1 1/2" (38) = 1'-0" (305) – 1:8

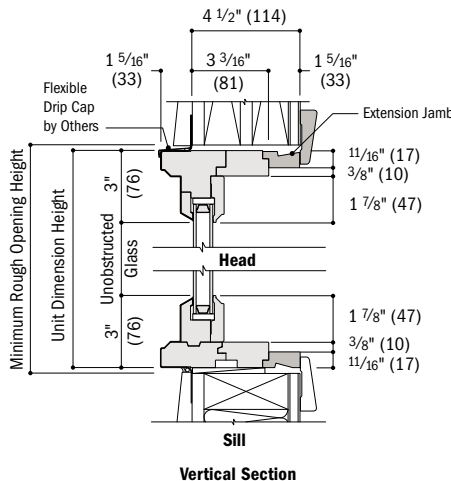

Tilt-Wash Picture/Transom Window Details

Scale 1 1/2" (38) = 1'-0" (305) – 1:8

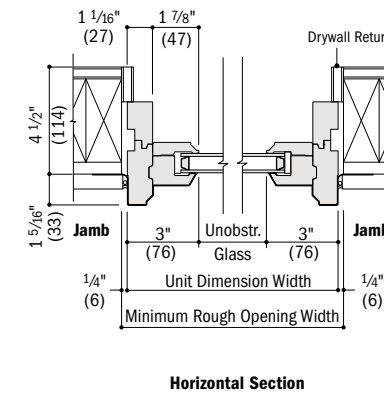
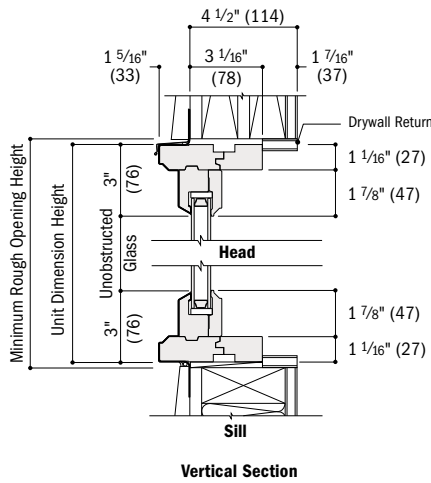

Vertical (ribbon) Joining Detail

Scale 1 1/2" (38) = 1'-0" (305) – 1:8

Overall Window Dimension Width

Sum of individual window widths plus 1/2" (13) per join.

Overall Minimum Rough Opening Width

Overall window dimension width plus 1/2" (13).

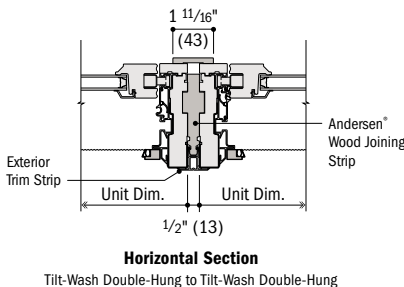

Extension Jamb Details

Scale 1 1/2" (38) = 1'-0" (305) – 1:8

Jamb for Drywall Return

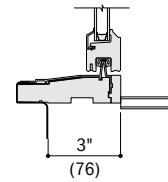

Factory-Applied Extension Jamb

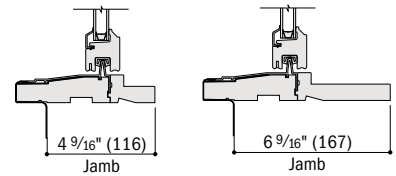

Field-Applied Extension Jamb

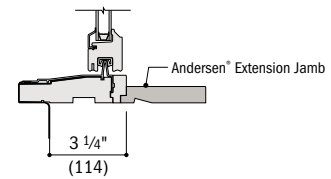

Separate Rough Openings Detail

Scale 1 1/2" (38) = 1'-0" (305) – 1:8

To meet structural requirements or to achieve a wider joined appearance, windows may be installed into separate rough openings having vertical support by others in combination with Andersen® exterior filler and exterior vinyl trim.

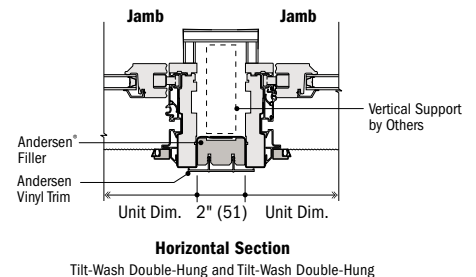

For more information on joining, refer to the Combination Designs section starting on page 57.

- Light-colored areas are parts included with window. Dark-colored areas are additional Andersen® parts required to complete window assembly as shown.
- **Minimum rough openings may need to be increased to allow for use of building wraps, flashing, sill panning, brackets, fasteners or other items. See installation information on page 74.**
- Details are for illustration only and are not intended to represent product installation methods or materials. Refer to product installation instructions at andersenwindows.com.
- Structural performance of any combination is only as high as the lowest structural performance of any individual product or join in the combination.
- Consult with an architect or structural engineer regarding minimum requirements for structural support members between adjacent rough openings.
- Dimensions in parentheses are in millimeters.



GLIDING WINDOWS

Tables of Sizes	25-26
Specifications	27
Grille Patterns	26
Window Details	27-28
Product Performance	65

GLIDING WINDOWS

FEATURES

FRAME

A The exterior of the frame is covered with a seamless Perma-Shield® rigid vinyl to eliminate corner joints/welds and strengthen rigidity. It provides an attractive appearance while minimizing maintenance.

B A laminated veneer lumber frame provides increased rigidity and minimizes racking during installation. It's treated with a water-repellent wood preservative for long-lasting* protection and performance.

C A full-perimeter installation flange makes installation easy and fast with little or no adjustment. It's fixed, seamless and integrated with the frame for weathertightness.

D Flexible weatherstrip around all four sides is factory installed, and provides a tight seal between the sash and frame.

SASH

E A polyester stabilized coat with a Flexacron® finish is electrostatically applied to penetrate all exterior surfaces for maximum protection and a lustrous finish.

F Wood sash members are treated with a water-repellent wood preservative for long-lasting* protection and performance.

G Sash interior surfaces are unfinished pine. Prefinished white interiors are also available.

H A raised track system makes operation less sensitive to dirt build-up for continually smooth performance.

TWO-TONE OPTION

Available with a two-tone color configuration, featuring a prefinished white interior and a Sandtone exterior. Some exterior components are visible from the interior. Corresponding picture windows, as well as grilles, are available to match.

CAUTION: Painting and staining may cause damage to rigid vinyl. Andersen does not warrant the adhesion or performance of homeowner-applied paint over vinyl or other factory-coated surfaces. For vinyl painting instructions and preparation, contact your Andersen supplier. Do not paint weatherstrip. Creosote-based stains should not come in contact with Andersen products. Abrasive cleaners or solutions containing corrosive solvents should not be used on Andersen products.

*Visit andersenwindows.com/warranty for details.

**Hardware is sold separately.

†Oil rubbed bronze is a "living finish" that will change with time and use, see limited warranty for details.

‡‡TruScene insect screens let in over 25% more fresh air than standard Andersen fiberglass insect screens.

*Flexacron® is a registered trademark of PPG Industries, Inc.

Naturally occurring variations in grain, color and texture of wood make each window one of a kind. All wood interiors are unfinished unless a finish is specified.

Printing limitations prevent exact replication of colors and finishes. See your Andersen supplier for actual color and finish samples.

Dimensions in parentheses are in millimeters.

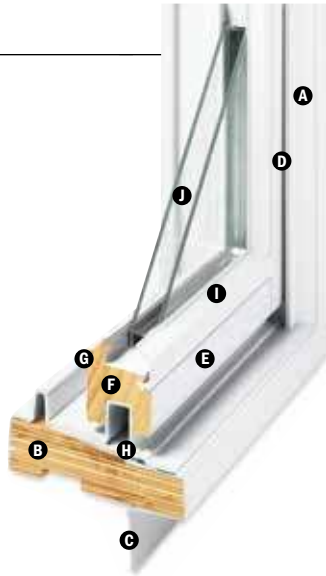

GLASS

I A rigid vinyl glazing bead, combined with a high-grade silicone glazing bed, keeps the glass bonded firmly to the sash, and helps minimize water and air infiltration.

J Glass options include:

- Low-E glass
- Low-E HeatLock® glass
- Low-E SmartSun™ glass
- Low-E SmartSun HeatLock glass
- Clear dual-pane glass

Tempered and other glass options are available. Contact your Andersen supplier.

A removable translucent film helps shield the glass from damage during delivery and construction, and simplifies finishing at the job site.

EXTERIORS & INTERIORS

EXTERIOR COLORS



INTERIOR OPTIONS



HARDWARE



Lock & Keeper

Stone | **White**

Optional finishes:**
Antique Brass | Black
Bright Brass
Oil Rubbed Bronze
Satin Nickel



Classic Series™ Pull

Stone | **White**

Stone finish is standard for pine interiors, and white finish is standard for white interiors. Bold name denotes finish shown.

HARDWARE FINISHES



Stone

White

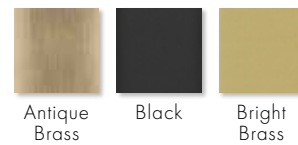

Antique Brass

Black

Bright Brass



Oil Rubbed Bronze†

Satin Nickel

ACCESSORIES Sold Separately

FRAME

Extension Jamb

Standard jamb depth is 2 3/4" (70). Extension jambs are available in unfinished pine or prefinished white. Some sizes may be veneered. Factory-applied and non-applied interior extension jambs are available in 1/16" (1.5) increments between 4 9/16" (114) and 7 1/8" (181). Extension jambs can be factory applied to either three sides (stool and apron) or four sides (picture frame casing).

Drywall Return

The 200 Series gliding window has a 2 3/4" (70) jamb depth with a flat interior surface for easy drywall return.

GRILLES

Grilles are available in a variety of configurations and widths. See page 15 for details.

EXTERIOR TRIM

Available with Andersen® exterior trim. See the Exterior Trim section on page 51.

HARDWARE

Window Opening Control Device Kit



A window opening control device kit is available that limits the sash travel to less than 4" (102) when the window is first opened. Available factory applied or field applied, in stone or white.

INSECT SCREENS

Insect screens are available with frame colors to match product exteriors.

TruScene® Insect Screens

Our TruScene insect screens let in over 25% more fresh air†† and provide 50% greater clarity than conventional Andersen insect screens, all while keeping out unwanted small insects.

Conventional Insect Screens

Conventional insect screens have charcoal gray powder-coated aluminum screen mesh.

Table of Gliding Window Sizes

Scale 1/8" (3) = 1'-0" (305) – 1:96

Window Dimension	2'-11 1/2" (902)	3'-11 1/2" (1207)	4'-11 1/2" (1511)	5'-11 1/2" (1816)
Minimum Rough Opening	3'-0" (914)	4'-0" (1219)	5'-0" (1524)	6'-0" (1829)
Unobstructed Glass (single sash only)	13 11/16" (348)	19 11/16" (500)	25 11/16" (652)	31 11/16" (805)

1'-5 1/2" (445)	1'-6" (457)	1'-11 1/2" (597)	2'-11 1/2" (902)	3'-5 1/2" (1054)	3'-11 1/2" (1207)	4'-5 1/2" (1359)	4'-11 1/2" (1511)
1'-6" (457)	1'-6" (457)	2'-0" (610)	3'-0" (914)	3'-6" (1067)	4'-0" (1219)	4'-6" (1372)	5'-0" (1524)
1'-11 1/2" (597)	2'-0" (610)	2'-0" (610)	2'-9 1/2" (749)	3'-5 1/2" (1054)	4'-0" (1219)	4'-6" (1372)	5'-0" (1524)
2'-11 1/2" (902)	3'-0" (914)	3'-0" (914)	3'-9 1/2" (914)	4'-5 1/2" (1359)	4'-11 1/2" (1511)	5'-5 1/2" (1664)	6'-11 1/2" (2069)
3'-5 1/2" (1054)	3'-6" (1067)	3'-6" (1067)	4'-5 1/2" (1359)	5'-1 1/2" (1359)	5'-11 1/2" (1816)	6'-5 1/2" (1961)	7'-11 1/2" (2366)
3'-11 1/2" (1207)	4'-0" (1219)	4'-0" (1219)	4'-9 1/2" (1219)	5'-5 1/2" (1664)	6'-0" (1829)	6'-6" (1982)	7'-11 1/2" (2366)
4'-5 1/2" (1359)	4'-6" (1372)	4'-6" (1372)	5'-5 1/2" (1664)	6'-1 1/2" (1664)	6'-11 1/2" (2069)	7'-5 1/2" (2222)	8'-11 1/2" (2627)
4'-11 1/2" (1511)	5'-0" (1524)	5'-0" (1524)	5'-9 1/2" (1524)	6'-5 1/2" (1961)	7'-0" (2126)	7'-6" (2279)	8'-11 1/2" (2627)

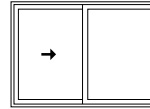

Active Stationary

Viewed from the exterior.

Grille patterns shown on page 26.

Details shown on page 27.

- Window Dimension always refers to outside frame-to-frame dimension.
- **Minimum Rough Opening dimensions may need to be increased to allow for use of building wraps, flashing, sill panning, brackets, fasteners or other items. See page 74 for more details.**
- Dimensions in parentheses are in millimeters.
- ◊Meets or exceeds clear opening area of 5.7 sq. ft. or 0.53 m², clear opening width of 20" (508) and clear opening height of 24" (610). See table on page 27.

Lock Location

Dimensions shown are from top of lock. Calculations based on installation with bottom of header height at 6'-10 1/2" (2096) from top of subfloor.

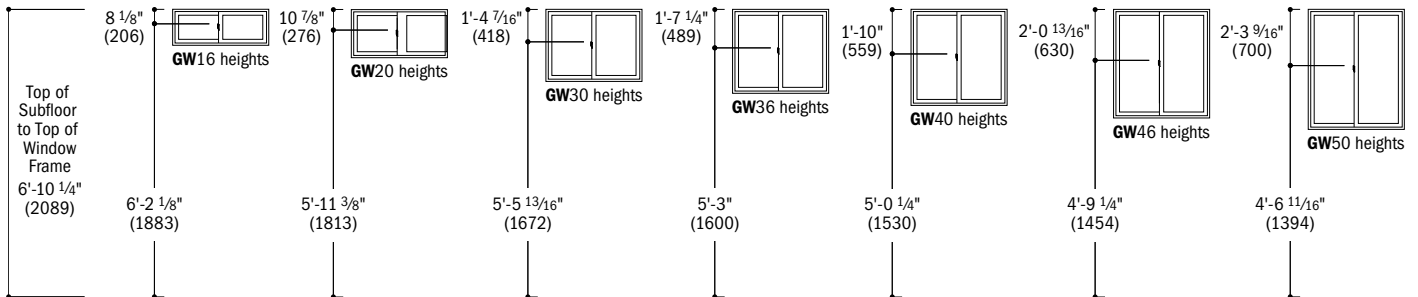

- Dimensions in parentheses are in millimeters.

GLIDING WINDOWS

Table of Picture Window Sizes

Scale 1/8" (3) = 1'-0" (305) – 1:96

Window Dimension	2'-11 1/2" (902)	3'-11 1/2" (1207)	4'-5 1/2" (1359)	4'-8 1/2" (1435)	4'-11 1/2" (1511)	5'-5 1/2" (1664)	5'-11 1/2" (1816)
Minimum Rough Opening	3'-0" (914)	4'-0" (1219)	4'-6" (1372)	4'-9" (1448)	5'-0" (1524)	5'-6" (1676)	6'-0" (1829)
Unobstructed Glass	29 1/2" (749)	41 1/2" (1054)	47 1/2" (1207)	50 1/2" (1283)	53 1/2" (1359)	59 1/2" (1511)	65 1/2" (1664)

2'-11 1/2" (902)	3'-0" (914)	3'-11 1/2" (1207)	4'-0" (1219)	4'-5 1/2" (1359)	4'-6" (1372)	4'-8 1/2" (1435)	4'-9" (1448)	4'-11 1/2" (1511)	5'-0" (1524)	5'-5 1/2" (1664)	5'-6" (1676)	5'-11 1/2" (1816)	6'-0" (1829)
244FX3030	244FX4030	244FX4630	244FX4930	244FX5030	244FX5630	244FX6030							
244FX3040	244FX4040	244FX4640	244FX4940	244FX5040	244FX5640	244FX6040							
244FX3046	244FX4046	244FX4646	244FX4946	244FX5046	244FX5646	244FX6046							
244FX3050	244FX4050	244FX4650	244FX4950	244FX5050	244FX5650	244FX6050							

Basic frame dimensions for gliding windows and picture windows are different. When joining, specify common extension jamb dimensions [i.e., 4 9/16" (116) or 6 9/16" (167)].

Grille patterns shown below.
Details shown on page 28.

* Window Dimension always refers to outside frame-to-frame dimension.

* **Minimum Rough Opening dimensions may need to be increased to allow for use of building wraps, flashing, sill panning, brackets, fasteners or other items.**

See page 74 for more details.

* Dimensions in parentheses are in millimeters.

Grille Patterns

	Prairie A	Colonial
Gliding		
Picture		

Number of lights and overall pattern varies with window size. Patterns may not be available in all configurations or sizes. Additional picture window patterns are available, contact your Andersen supplier. Specified equal light and custom patterns are also available. For more grille options, see page 15 or visit andersenwindows.com/grilles.

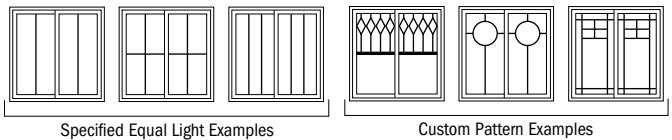

Gliding Window Opening and Area Specifications

Window Number	Clear Opening Area Sq. Ft./ (m ²)	Clear Opening Full Open Position		Glass Area Sq. Ft./ (m ²)	Top of Subfloor to Top of Inside Sill Stop Inches/ (mm)	Overall Window Area Sq. Ft./ (m ²)
		Width Inches/ (mm)	Height Inches/ (mm)			
244GW3020	2.10 (0.20)	15" (381)	20 1/8" (511)	3.32 (0.31)	60 7/16" (1535)	5.79 (0.54)
244GW3030	3.34 (0.31)	15" (381)	32 1/8" (816)	5.60 (0.52)	48 7/16" (1230)	8.75 (0.81)
244GW3036	3.97 (0.37)	15" (381)	38 1/8" (968)	6.74 (0.63)	42 7/16" (1078)	10.23 (0.95)
244GW3040	4.59 (0.43)	15" (381)	44 1/8" (1121)	7.88 (0.73)	36 7/16" (925)	11.71 (1.09)
244GW4016	2.06 (0.19)	21" (533)	14 1/8" (359)	3.14 (0.29)	66 7/16" (1687)	5.77 (0.54)
244GW4020	2.93 (0.27)	21" (533)	20 1/8" (511)	4.78 (0.44)	60 7/16" (1535)	7.75 (0.72)
244GW4030	4.68 (0.44)	21" (533)	32 1/8" (816)	8.06 (0.75)	48 7/16" (1230)	11.71 (1.09)
244GW4036	5.56 (0.52)	21" (533)	38 1/8" (968)	9.70 (0.90)	42 7/16" (1078)	13.69 (1.27)
244GW4040 ◊	6.43 (0.60)	21" (533)	44 1/8" (1120)	11.34 (1.05)	36 7/16" (925)	15.67 (1.46)
244GW4046 ◊	7.31 (0.68)	21" (533)	50 1/8" (1273)	12.98 (1.21)	30 7/16" (773)	17.65 (1.64)
244GW4050 ◊	8.18 (0.76)	21" (533)	56 1/8" (1425)	14.62 (1.36)	24 7/16" (620)	19.63 (1.82)
244GW5030 ◊	6.02 (0.56)	27" (686)	32 1/8" (816)	10.52 (0.98)	48 7/16" (1230)	14.69 (1.37)
244GW5036 ◊	7.14 (0.66)	27" (686)	38 1/8" (968)	12.66 (1.18)	42 7/16" (1078)	17.15 (1.59)
244GW5040 ◊	8.27 (0.77)	27" (686)	44 1/8" (1121)	14.80 (1.38)	36 7/16" (925)	19.63 (1.82)
244GW5046 ◊	9.39 (0.87)	27" (686)	50 1/8" (1273)	16.94 (1.57)	30 7/16" (773)	22.11 (2.05)
244GW5050 ◊	10.52 (0.98)	27" (686)	56 1/8" (1425)	19.08 (1.77)	24 7/16" (620)	24.59 (2.28)
244GW6030 ◊	7.36 (0.68)	33" (838)	32 1/8" (816)	12.98 (1.21)	48 7/16" (1230)	17.63 (1.64)
244GW6036 ◊	8.73 (0.81)	33" (838)	38 1/8" (968)	15.62 (1.45)	42 7/16" (1078)	20.61 (1.92)
244GW6040 ◊	10.11 (0.94)	33" (838)	44 1/8" (1121)	18.26 (1.70)	36 7/16" (925)	23.59 (2.19)
244GW6046 ◊	11.48 (1.07)	33" (838)	50 1/8" (1273)	20.90 (1.94)	30 7/16" (773)	26.56 (2.47)
244GW6050 ◊	12.86 (1.20)	33" (838)	56 1/8" (1425)	23.54 (2.19)	24 7/16" (620)	29.54 (2.74)

- * Top of Subfloor to Top of Inside Sill Stop is calculated based upon a structural header height of 6'-10 1/2" (2096).
- * Dimensions in parentheses are in millimeters or square meters.
- ◊ Meets or exceeds clear opening area of 5.7 sq. ft. or 0.53 m², clear opening width of 20" (508) and clear opening height of 24" (610).

Picture Window Area Specifications

Window Number	Glass Area Sq. Ft./ (m ²)	Overall Window Area Sq. Ft./ (m ²)
244FX3030	6.04 (0.56)	8.75 (0.81)
244FX3040	8.50 (0.79)	11.71 (1.09)
244FX3046	9.73 (0.90)	13.19 (1.23)
244FX3050	10.96 (1.02)	14.67 (1.36)
244FX4030	8.50 (0.79)	11.71 (1.09)
244FX4040	11.96 (1.11)	15.67 (1.46)
244FX4046	13.69 (1.27)	17.65 (1.64)
244FX4050	15.42 (1.43)	19.63 (1.82)
244FX4630	9.73 (0.90)	13.19 (1.23)
244FX4640	13.69 (1.27)	17.65 (1.64)
244FX4646	15.67 (1.46)	19.88 (1.85)
244FX4650	17.65 (1.64)	22.11 (2.05)
244FX4930	10.35 (0.96)	13.93 (1.29)
244FX4940	14.55 (1.35)	18.64 (1.73)
244FX4946	16.66 (1.55)	20.99 (1.95)
244FX4950	18.76 (1.74)	23.35 (2.17)
244FX5030	10.96 (1.02)	14.67 (1.36)
244FX5040	15.42 (1.43)	19.63 (1.82)
244FX5046	17.65 (1.64)	22.11 (2.05)
244FX5050	19.88 (1.85)	24.59 (2.28)
244FX5630	12.19 (1.13)	16.15 (1.50)
244FX5640	17.15 (1.59)	21.61 (2.01)
244FX5646	19.63 (1.82)	24.34 (2.26)
244FX5650	22.11 (2.05)	27.06 (2.51)
244FX6030	13.42 (1.25)	17.63 (1.64)
244FX6040	18.88 (1.75)	23.59 (2.19)
244FX6046	21.61 (2.01)	26.56 (2.47)
244FX6050	24.34 (2.26)	29.54 (2.75)

- * Dimensions in parentheses are in square meters.

 200 Series
Gliding Windows

Gliding Window Details

Scale 1 1/2" (38) = 1'-0" (305) – 1:8

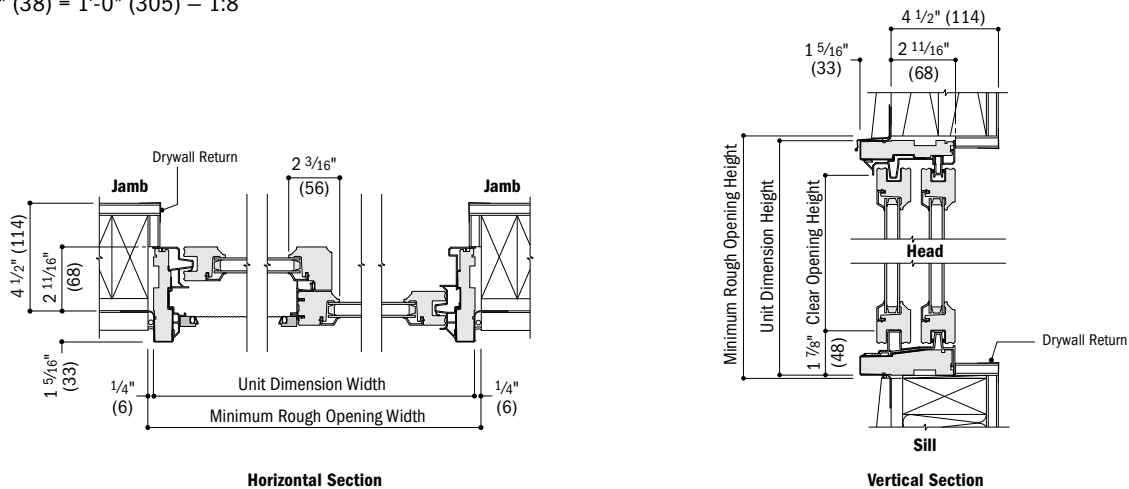

- * Light-colored areas are parts included with window. Dark-colored areas are additional Andersen® parts required to complete window assembly as shown.
- * Minimum rough openings may need to be increased to allow for use of building wraps, flashing, sill panning, brackets, fasteners or other items. See installation information on page 74.
- * Details are for illustration only and are not intended to represent product installation methods or materials. Refer to product installation instructions at andersenwindows.com.
- * Dimensions in parentheses are in millimeters.

GLIDING WINDOWS

Picture Window Details

Scale 1 1/2" (38) = 1'-0" (305) – 1:8

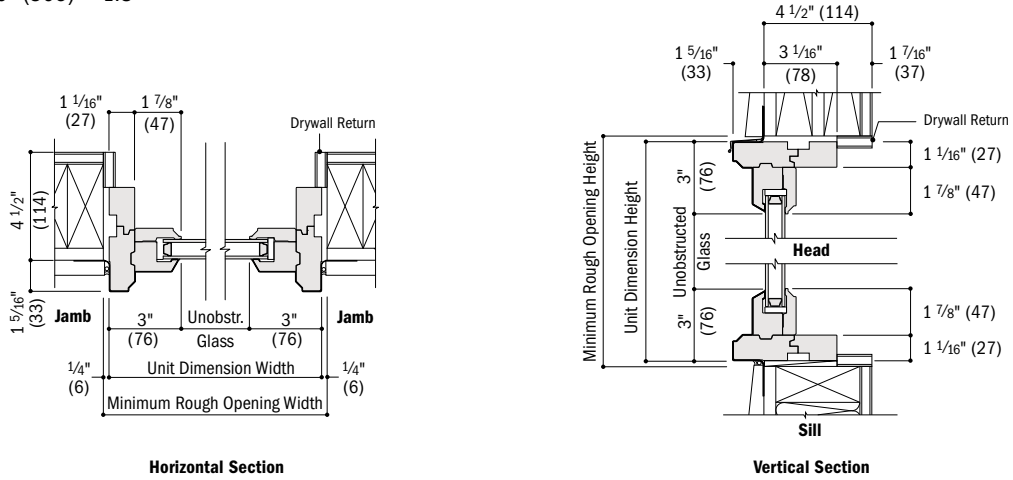

Separate Rough Openings Detail

Scale 1 1/2" (38) = 1'-0" (305) – 1:8

To meet structural requirements or to achieve a wider joined appearance, windows may be installed into separate rough openings having vertical support by others in combination with Andersen® exterior filler and exterior vinyl trim.

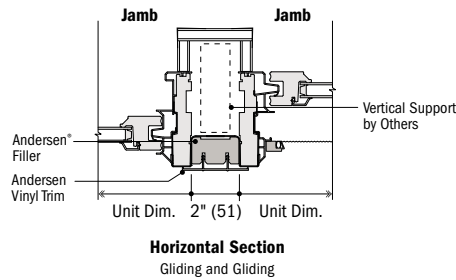

- Light-colored areas are parts included with window. Dark-colored areas are additional Andersen® parts required to complete window assembly as shown.
- **Minimum rough openings may need to be increased to allow for use of building wraps, flashing, sill panning, brackets, fasteners or other items. See installation information on page 74.**
- Details are for illustration only and are not intended to represent product installation methods or materials. Refer to product installation instructions at andersenwindows.com.
- Structural performance of any combination is only as high as the lowest structural performance of any individual product or join in the combination.
- Consult with an architect or structural engineer regarding minimum requirements for structural support members between adjacent rough openings.
- Dimensions in parentheses are in millimeters.

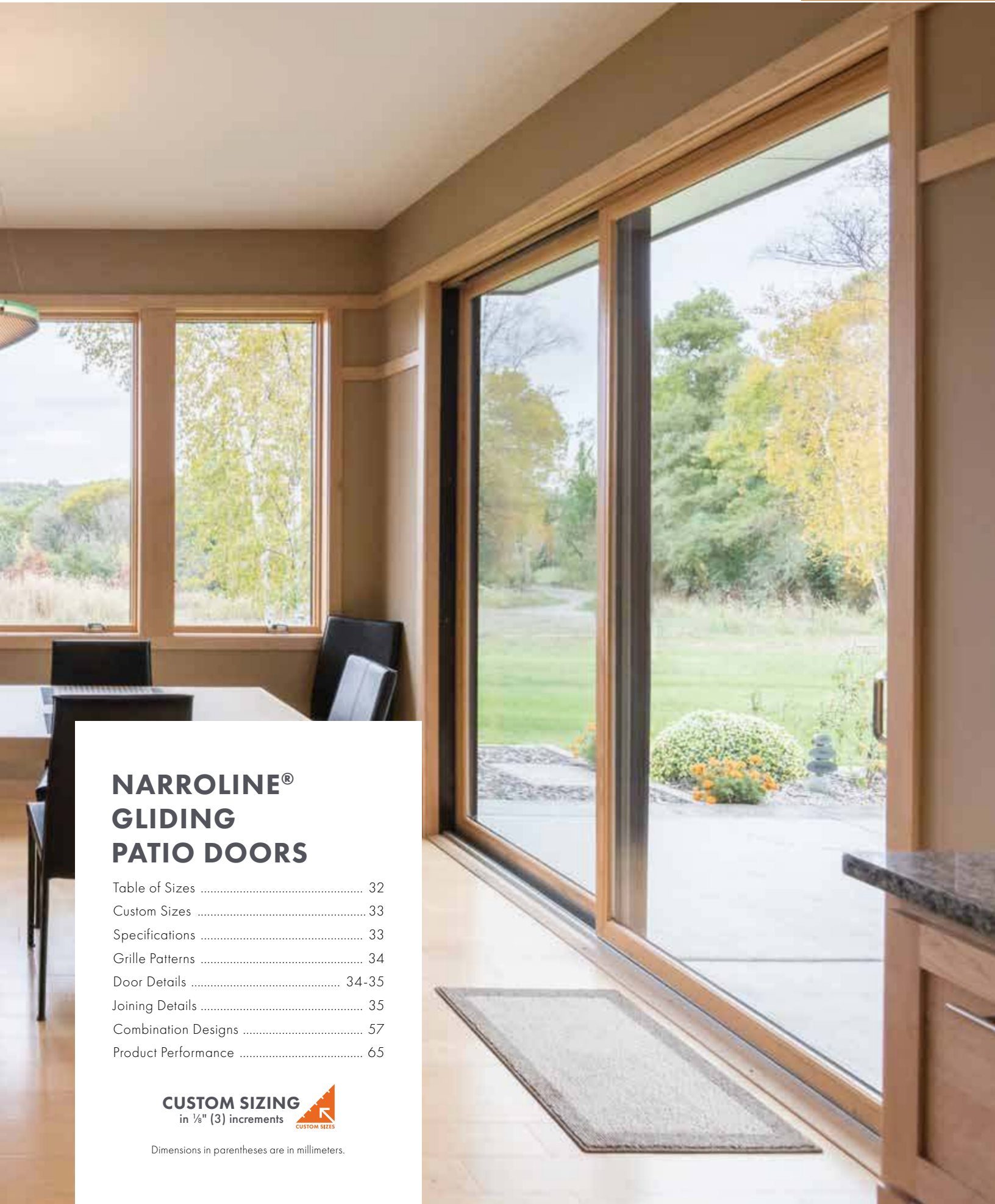

NARROLINE[®] GLIDING PATIO DOORS

Table of Sizes	32
Custom Sizes	33
Specifications	33
Grille Patterns	34
Door Details	34-35
Joining Details	35
Combination Designs	57
Product Performance	65

CUSTOM SIZING
in 1/8" (3) increments 

Dimensions in parentheses are in millimeters.

NARROLINE® GLIDING PATIO DOORS

FEATURES

FRAME

A All basic exterior frame members are covered with a Perma-Shield® rigid vinyl cladding that maintains an attractive appearance while minimizing maintenance.

B Wood frame members are treated with a water-repellent preservative for long-lasting* protection and performance.

C Interior frame trim pieces match the interior of the panel. Available in pine, maple or oak wood species and prefinished white, dark bronze or black.

D A flexible vinyl weatherstrip on the head and side jambs provides a positive seal between the frame and panels.

Factory-assembled two-panel doors are available and arrive at the job site ready to install. Unassembled doors are also available and require job site assembly.

SILL

E For single stationary and two-panel doors, the sills have an anodized aluminum track with a stainless steel cap that resists stain, rust and denting. On four-panel doors, the sill has an attractive water-repellent baked-on finish in a neutral gray color. A thermal barrier reduces conductive heat loss and limits condensation on the inside. The exterior portion of the sill is also anodized aluminum.

For single stationary and two-panel doors, sills can also be ordered with the water-repellent baked-on finish in a neutral gray color.

PANEL

F The exterior of the wood door panel is protected by a low-maintenance urethane base finish.

G Laminated veneer lumber panels provide excellent structural stability and energy efficiency.

Panel interior surfaces are unfinished pine, ready for stain or paint finish.

Dual ball-bearing rollers on door panels provide smooth gliding operation with self-contained leveling adjusters.

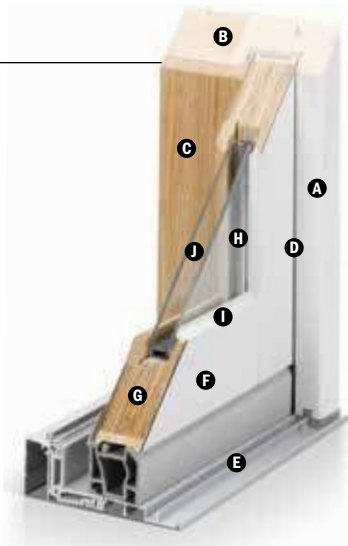

Flexible Seal



A full-length combination weatherstrip/interlock system provides a flexible seal at the meeting stile.

GLASS

H Glass spacers are available in black or stainless steel.

I Panels are silicone bed glazed and finished with an interior wood stop.

J Dual-pane glass options include:

- Low-E tempered glass
- Low-E HeatLock® tempered glass
- Low-E SmartSun™ tempered glass
- Low-E SmartSun HeatLock tempered glass
- Low-E Sun tempered glass
- Clear dual-pane tempered glass

For even greater energy performance, 1" (25) triple-pane glass is available in these options:

- Low-E tempered glass
- Low-E Enhanced tempered glass
- Low-E Enhanced HeatLock tempered glass
- Low-E SmartSun tempered glass
- Low-E SmartSun Enhanced tempered glass
- Low-E SmartSun Enhanced HeatLock tempered glass

Additional glass options are available. Contact your Andersen supplier.

A removable translucent film helps shield the glass from damage during delivery and construction, and simplifies finishing at the job site.

EXTERIORS & INTERIORS

EXTERIOR COLORS



INTERIOR WOOD SPECIES & INTERIOR PAINT COLORS

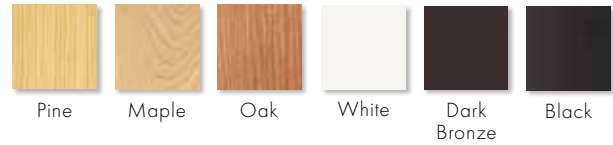

Painted interiors are on pine.

HARDWARE Sold Separately



Bold name denotes finish shown.

HARDWARE FINISHES



Mix-and-match interior and exterior style and finish hardware options are available.

Bright brass and satin nickel finishes on patio door hardware are a PVD finish and feature a 10-year limited warranty.

Albany and Tribeca hardware are zinc die cast with durable powder-coated finish. Other hardware is solid drop-forged brass.

Naturally occurring variations in grain, color and texture of wood make each window one of a kind. All wood interiors are unfinished unless a finish is specified.

Printing limitations prevent exact replication of colors and finishes. See your Andersen supplier for actual color and finish samples.

Dimensions in parentheses are in millimeters.

*Visit andersenwindows.com/warranty for details.

**These finishes are "living finishes" that will change with time and use, see limited warranty for details.

Andersen patio doors are not intended for use as entry doors.

HARDWARE

Reachout Locking Hardware



The unique Andersen® reachout locking hardware pulls the door panel snugly into the jamb for a weather tight seal and enhanced security.

ACCESSORIES Sold Separately

FRAME

Extension Jamb

Standard jamb depth is 4 9/16" (116). Pine, maple and oak veneers or prefinished white interior extension jambs are available in 1/16" (1.5) increments between 5 1/16" (129) and 7 1/8" (181).

Threshold



A maple or oak threshold is available for finishing the interior of the sill.

Ramped Sill Insert



Ramped sills in maple or oak provide a smooth transition from interior to exterior, and can be used with a retractable insect screen but not a gliding insect screen. Check with local and federal officials to determine if product meets accessibility codes. Shown with an Andersen 400 Series Frenchwood® gliding patio door.

Sill Support



An aluminum sill support is designed to lock into a channel under the sill and tie back into the wall. This will offer support to the outermost sill section when needed. Available in a neutral gray finish.

HARDWARE

Exterior Keyed Lock



A six-pin key cylinder lock allows the door to be locked and unlocked from the exterior. Available in finishes that coordinate with the hardware.

Auxiliary Foot Lock



Provides an extra measure of security when the door is in a locked position. The lock can be set so the door is fully closed or partially open to provide a secure venting position. Available in all hardware finishes.

INSECT SCREENS

Screens have a long-lasting fiberglass screen mesh with a charcoal gray finish. Frames are color matched to the exterior of the door.

Gliding Screen

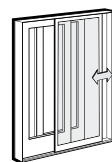

Patented square-corner joint construction adds considerable strength to the frame members. Gliding screens have Delrin® injection-molded bottom rollers with self-contained leveling adjusters, providing smooth operation. Interior and exterior pulls and latch are provided. Available for two-and four-panel doors.

Retractable Screen

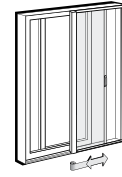

Our premium retractable screen for two- and four-panel doors has an integrated design, allowing it to glide side to side across the width of the opening and disappear when not in use. The screen features high-weather and retention performance, tear-resistant screen mesh, and quality metal hardware, along with an owner-to-owner 10-year limited warranty. Available in all exterior colors.

GRILLES

Grilles are available in a variety of configurations and widths. See page 15 for details.

EXTERIOR TRIM

Available with Andersen exterior trim. See the Exterior Trim section starting on page 51.

SIDELIGHTS

Stationary units can be selected for use as sidelights. See the size table on page 32 for size options.

CAUTION: Painting and staining may cause damage to rigid vinyl. Andersen does not warrant the adhesion or performance of homeowner-applied paint over vinyl or other factory-coated surfaces. For vinyl painting instructions and preparation, contact your Andersen supplier. Do not paint weatherstrip. Creosote-based stains should not come in contact with Andersen products. Abrasive cleaners or solutions containing corrosive solvents should not be used on Andersen products.

*Visit andersenwindows.com/warranty for details.
"Delrin" is a registered trademark of E.I. du Pont de Nemours and Company.
Andersen patio doors are not intended for use as entry doors.
Dimensions in parentheses are in millimeters.

NARROLINE® GLIDING PATIO DOORS

Patio Door Heights

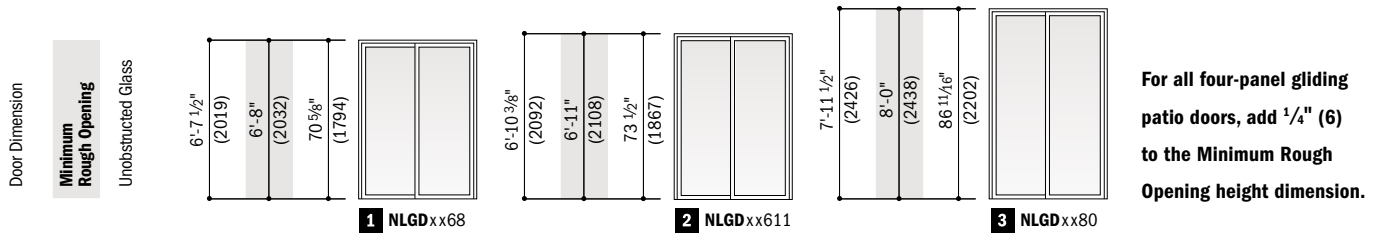

Table of Narroline® Gliding Patio Door Sizes

Scale 1/8" (3) = 1'-0" (305) – 1:96

Door Dimension	2'-8"	4'-11 1/4"	4'-11 1/4"	9'-9"
(813)	(1505)	(1505)	(2972)	
Minimum Rough Opening	2'-8 3/4" (832)	5'-0" (1524)	5'-0" (1524)	9'-9 3/4" (2991)
Unobstructed Glass (single panel only)	24 1/2" (622)	24 1/2" (622)	24 1/2" (622)	24 1/2" (622)



Custom-size doors are available in 1/8" (3) increments. See page 33 for custom sizes and specifications.

Viewed from the exterior. Arrow indicates direction of panel operation. Stationary (S) doors can be used as an individual unit or as a sidelight.

Grille patterns shown on page 34.
Details shown on pages 34-35.

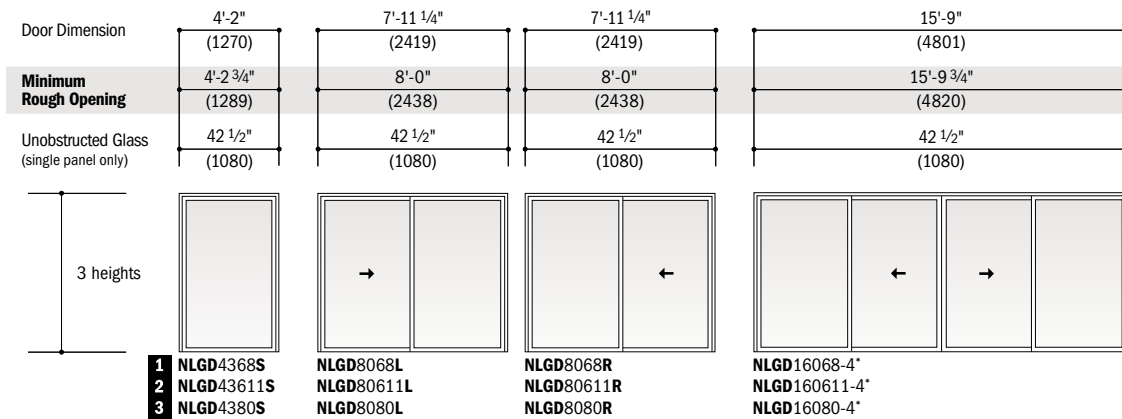
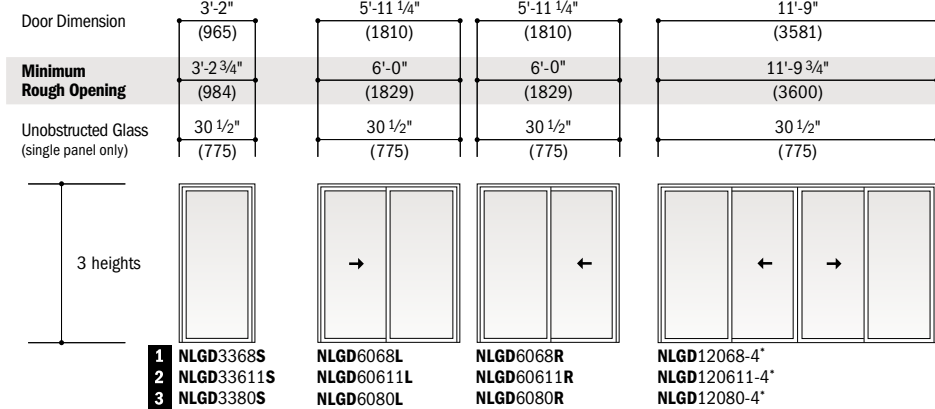
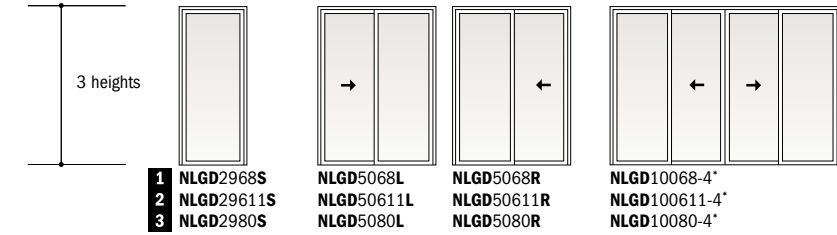

* Door Dimension always refers to outside frame-to-frame dimension.
 * **Minimum Rough Opening dimensions may need to be increased to allow for use of building wraps, flashing, sill panning, brackets, fasteners or other items. See page 74 for more details.**
 * Dimensions in parentheses are in millimeters.
 * Add 1/4" (6) to the Minimum Rough Opening height dimension for four-panel doors.

Order Designation Descriptions

Viewed from the exterior.

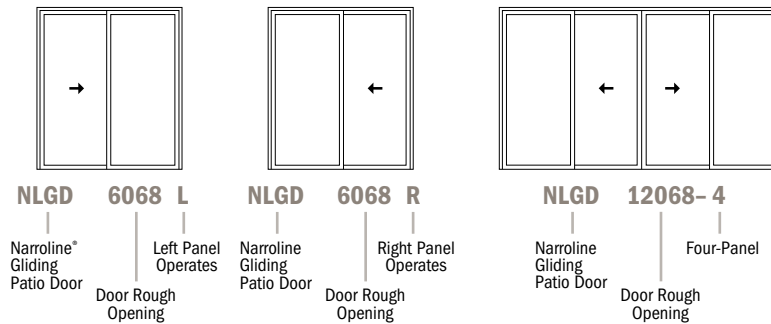

Custom Sizes and Specification Formulas

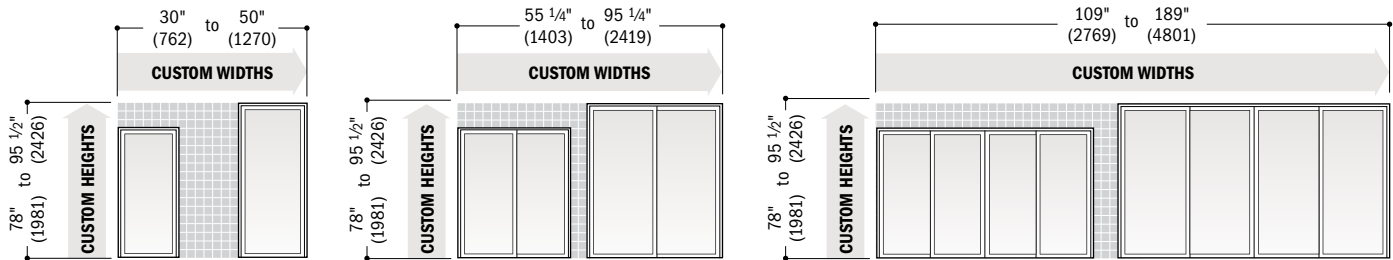

200 Series
Narrowline® Gliding
Patio Doors

Clear Opening	Two-Panel	Minimum R.O.	Single-Panel & Two-Panel	Unobst. Glass	Single-Panel
	Two-Panel Width = width + 2) - 7.5" (191) Height = height - 4.125" (105)		Single-Panel & Two-Panel Width = width + 3/4" (19) Height = height + 1/2" (13)		Single-Panel Width = width - 9.5" (241) Height = height - 8.859" (225)
	Four-Panel Width = (width + 2) - 13.75" (349) Height = height - 4.125" (105)		Four-Panel Width = width + 3/4" (19) Height = height + 3/4" (19)		Two-Panel Width = width - 10.25" (260) Height = height - 8.859" (225)
					Four-Panel Width = width - 19.0" (483) Height = height - 8.859" (225)



Available in 1/8" (3) increments between minimum and maximum widths and heights shown. Some restrictions apply. Measurement guide can be found at

andersenwindows.com/measure.

• **Clear Opening** formulas provide dimensions for determining area available for egress. Vent opening, or area available for passage of air, is equal to clear opening.
 • **Minimum R.O.** (minimum rough opening) formulas provide minimum rough opening width and height dimensions. **Unobst. Glass** (unobstructed glass) formulas provide dimensions for determining area available for passage of light.
 • Dimensions in parentheses are in millimeters.

Two-Panel and Four-Panel Narrowline® Gliding Patio Door Opening and Area Specifications

Door Number	Clear Opening Area Sq. Ft./ (m ²)	Clear Opening in Full Open Position		Glass Area Sq. Ft./ (m ²)	Vent Area Sq. Ft./ (m ²)	Overall Door Area Sq. Ft./ (m ²)
		Width Inches/(mm)	Height Inches/(mm)			
NLGD5068	11.58 (1.08)	22 1/8" (562)	75 3/8" (1915)	24.03 (2.23)	11.58 (1.08)	32.71 (3.04)
NLGD6068	14.72 (1.37)	28 1/8" (714)	75 3/8" (1915)	29.92 (2.78)	14.72 (1.37)	39.34 (3.66)
NLGD8068	21.00 (1.95)	40 1/8" (1020)	75 3/8" (1915)	41.69 (3.87)	21.00 (1.95)	52.59 (4.89)
NLGD10068	23.42 (2.18)	44 3/4" (1137)	75 3/8" (1915)	48.08 (4.47)	23.42 (2.18)	64.59 (6.00)
NLGD12068	29.70 (2.76)	56 3/4" (1441)	75 3/8" (1915)	59.84 (5.56)	29.71 (2.76)	77.84 (7.23)
NLGD16068	42.27 (3.93)	80 3/4" (2051)	75 3/8" (1915)	83.36 (7.74)	42.27 (3.93)	104.34 (9.69)
NLGD50611	12.04 (1.12)	22 1/8" (562)	78 3/16" (1986)	25.01 (2.32)	12.04 (1.12)	33.89 (3.15)
NLGD60611	15.31 (1.42)	28 1/8" (714)	78 3/16" (1986)	31.14 (2.89)	15.31 (1.42)	40.76 (3.79)
NLGD80611	21.84 (2.03)	40 1/8" (1020)	78 3/16" (1986)	43.39 (4.03)	21.84 (2.03)	54.49 (5.06)
NLGD100611	24.30 (2.26)	44 3/4" (1137)	78 3/16" (1986)	50.04 (4.65)	24.30 (2.26)	66.93 (6.22)
NLGD120611	30.81 (2.86)	56 3/4" (1441)	78 3/16" (1986)	62.28 (5.79)	30.81 (2.86)	80.66 (7.49)
NLGD160611	43.85 (4.07)	80 3/4" (2051)	78 3/16" (1986)	86.76 (8.06)	43.84 (4.07)	108.12 (10.04)
NLGD5080	14.04 (1.30)	22 1/8" (562)	91 3/8" (2321)	29.48 (2.74)	14.04 (1.30)	39.29 (3.65)
NLGD6080	17.85 (1.66)	28 1/8" (714)	91 3/8" (2321)	36.70 (3.41)	17.85 (1.66)	47.25 (4.39)
NLGD8080	25.46 (2.37)	40 1/8" (1020)	91 3/8" (2321)	51.14 (4.75)	25.46 (2.37)	63.17 (5.87)
NLGD10080	28.40 (2.64)	44 3/4" (1137)	91 3/8" (2321)	58.96 (5.48)	28.40 (2.64)	77.59 (7.21)
NLGD12080	36.01 (3.35)	56 3/4" (1441)	91 3/8" (2321)	73.40 (6.82)	36.01 (3.35)	93.51 (8.69)
NLGD16080	51.24 (4.76)	80 3/4" (2051)	91 3/8" (2321)	102.28 (9.50)	51.24 (4.76)	125.34 (11.65)

• Dimensions in parentheses are in millimeters or square meters.

Stationary Narrowline® Gliding Patio Door Area Specifications

Door Number	Glass Area Sq. Ft./ (m ²)	Overall Door Area Sq. Ft./ (m ²)
NLGD2968	12.02 (1.12)	17.67 (1.64)
NLGD3368	14.96 (1.39)	20.98 (1.95)
NLGD4368	20.84 (1.94)	27.60 (2.56)
NLGD29611	12.51 (1.16)	18.31 (1.70)
NLGD33611	15.57 (1.45)	21.74 (2.02)
NLGD43611	21.69 (2.02)	28.60 (2.66)
NLGD2980	14.74 (1.37)	21.22 (1.97)
NLGD3380	18.35 (1.71)	25.20 (2.34)
NLGD4380	25.57 (2.34)	33.16 (3.08)

• Dimensions in parentheses are in square meters.

NARROLINE® GLIDING PATIO DOORS

Grille Patterns

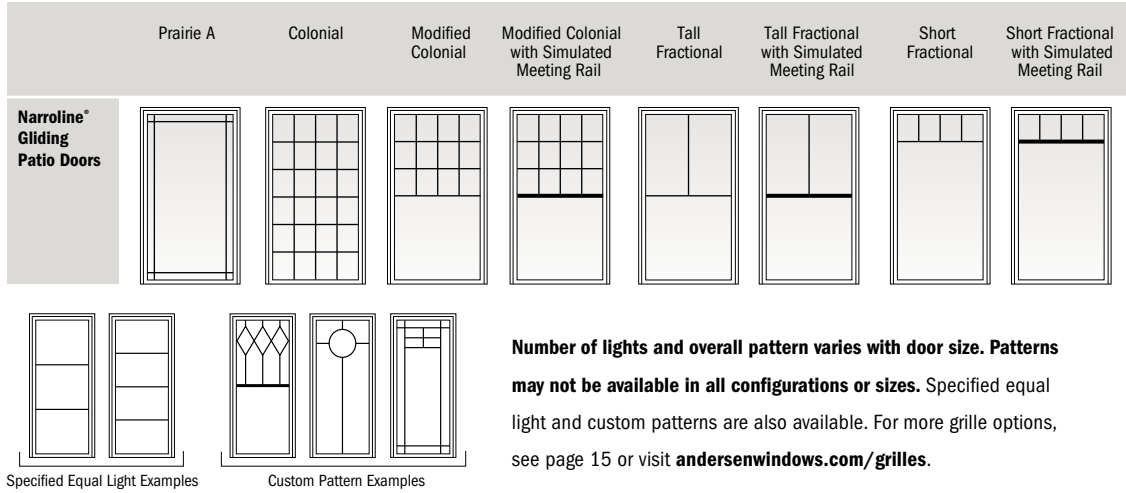

Number of lights and overall pattern varies with door size. Patterns may not be available in all configurations or sizes. Specified equal light and custom patterns are also available. For more grille options, see page 15 or visit andersenwindows.com/grilles.

Narroline® Gliding Patio Door Details

Scale 1 1/2" (38) = 1'-0" (305) – 1:8

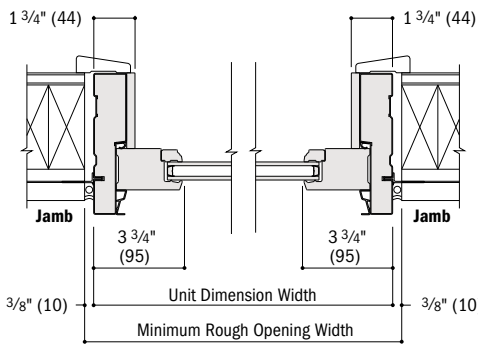

Horizontal Section
Stationary

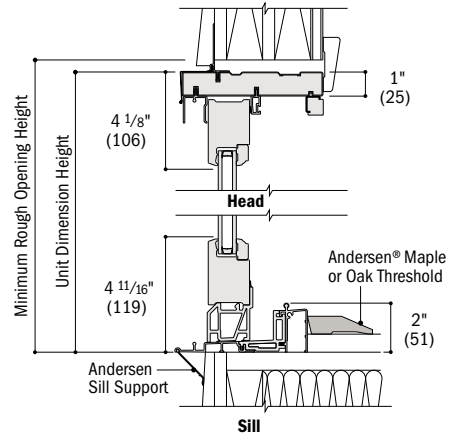

Vertical Section
Stationary

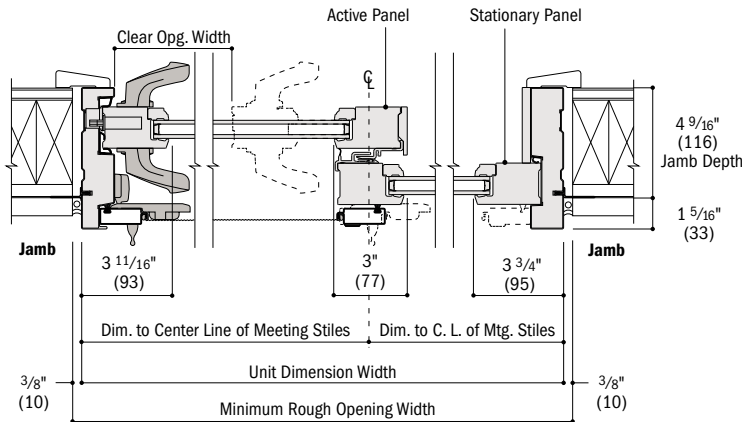

Horizontal Section
Two-Panel

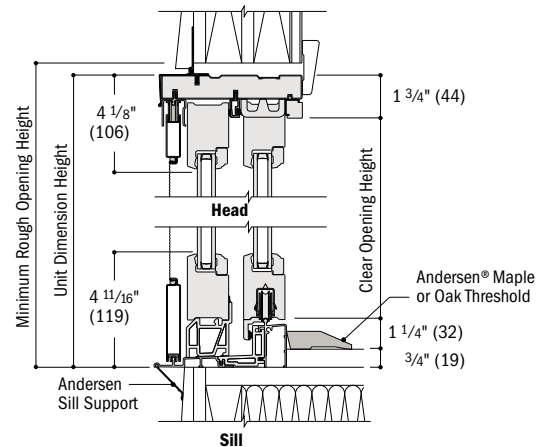

Vertical Section

continued on next page

- 4 9/16" (116) base jamb depth measurement is from back side of installation flange.
- Light-colored areas are parts included with door. Dark-colored areas are additional Andersen® parts required to complete door assembly as shown.
- **Minimum rough openings may need to be increased to allow for use of building wraps, flashing, sill panning, brackets, fasteners or other items. See installation information on page 74.**
- Details are for illustration only and are not intended to represent product installation methods or materials. Refer to product installation instructions at andersenwindows.com.
- Dimensions in parentheses are in millimeters.

Narroline® Gliding Patio Door Details (continued)

Scale 1 1/2" (38) = 1'-0" (305) – 1:8

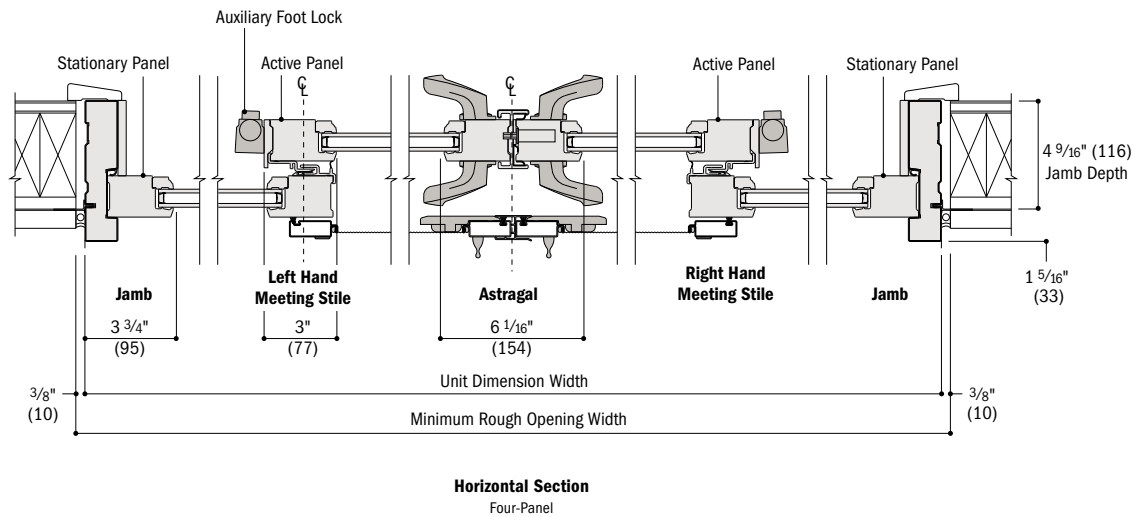

Ramped Sill Detail

Scale 1 1/2" (38) = 1'-0" (305) – 1:8

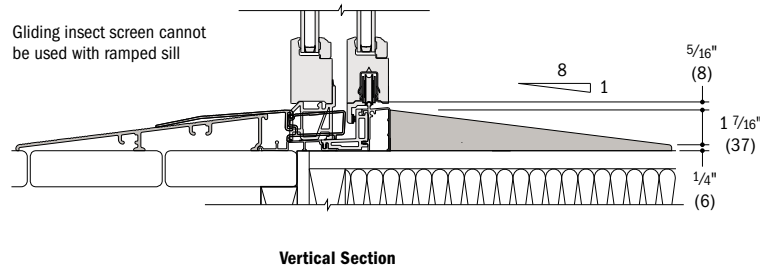

Vertical Joining Detail – Jamb-to-Jamb

Scale 1 1/2" (38) = 1'-0" (305) – 1:8

Overall Door Dimension Width

Sum of individual door widths plus 1/16" (1.5) per join.

Overall Minimum Rough Opening Width

Overall door width plus 3/4" (19).

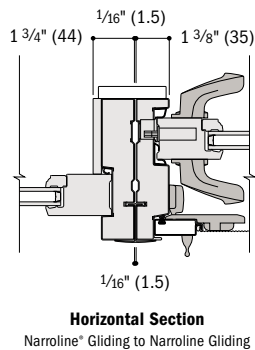

Separate Rough Openings Detail

Scale 1 1/2" (38) = 1'-0" (305) – 1:8

To meet structural requirements or to achieve a wider joined appearance, doors may be installed into separate rough openings having vertical support by others in combination with Andersen® exterior filler and exterior vinyl trim.

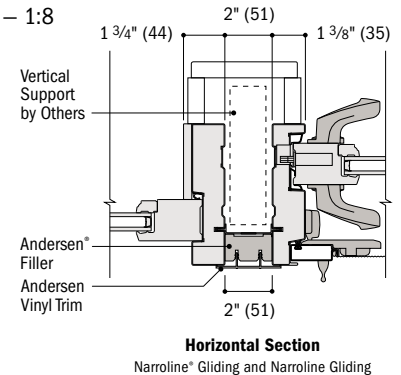

Vertical Joining Detail – Fiberglass

Scale 1 1/2" (38) = 1'-0" (305) – 1:8

Overall Door Dimension Width

Sum of individual door widths plus 3/4" (19) per join.

Overall Minimum Rough Opening Width

Overall door width plus 3/4" (19).

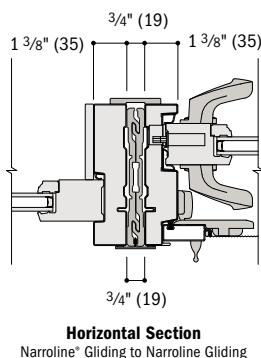

Andersen does not recommend joining of receiver jamb to receiver jamb.

For more information on joining, refer to the Combination Designs section starting on page 57.

- 4 9/16" (116) base jamb depth measurement is from back side of installation flange.
- Light-colored areas are parts included with door. Dark-colored areas are additional Andersen® parts required to complete door assembly as shown.
- **Minimum rough openings may need to be increased to allow for use of building wraps, flashing, sill panning, brackets, fasteners or other items. See installation information on page 74.**
- Details are for illustration only and are not intended to represent product installation methods or materials. Refer to product installation instructions at andersenwindows.com.
- Structural performance of any combination is only as high as the lowest structural performance of any individual product or join in the combination.
- Andersen recommends installation of doors into separate rough openings. Consult with an architect or structural engineer regarding minimum requirements for structural support members between adjacent rough openings.
- Dimensions in parentheses are in millimeters.

NOTES

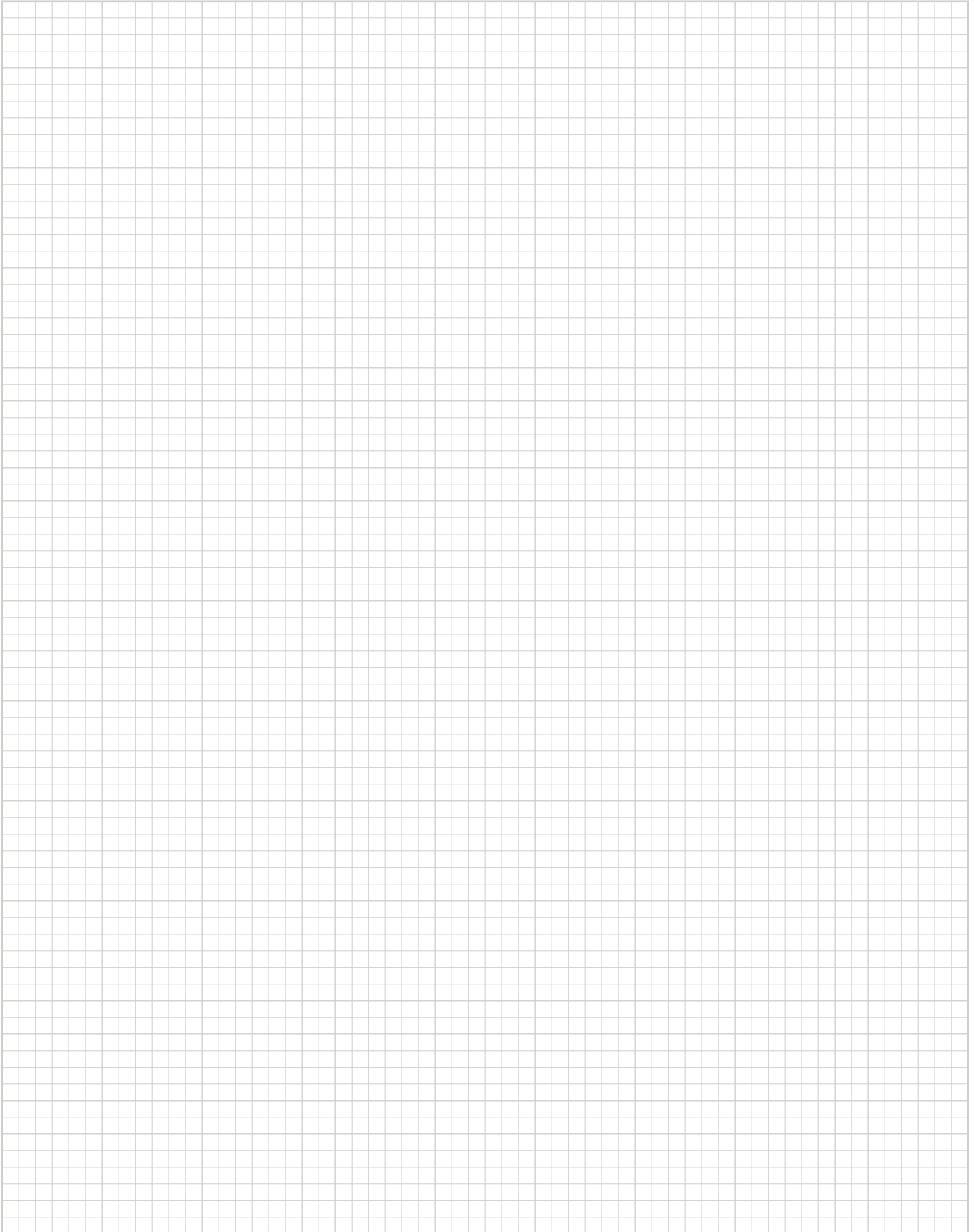

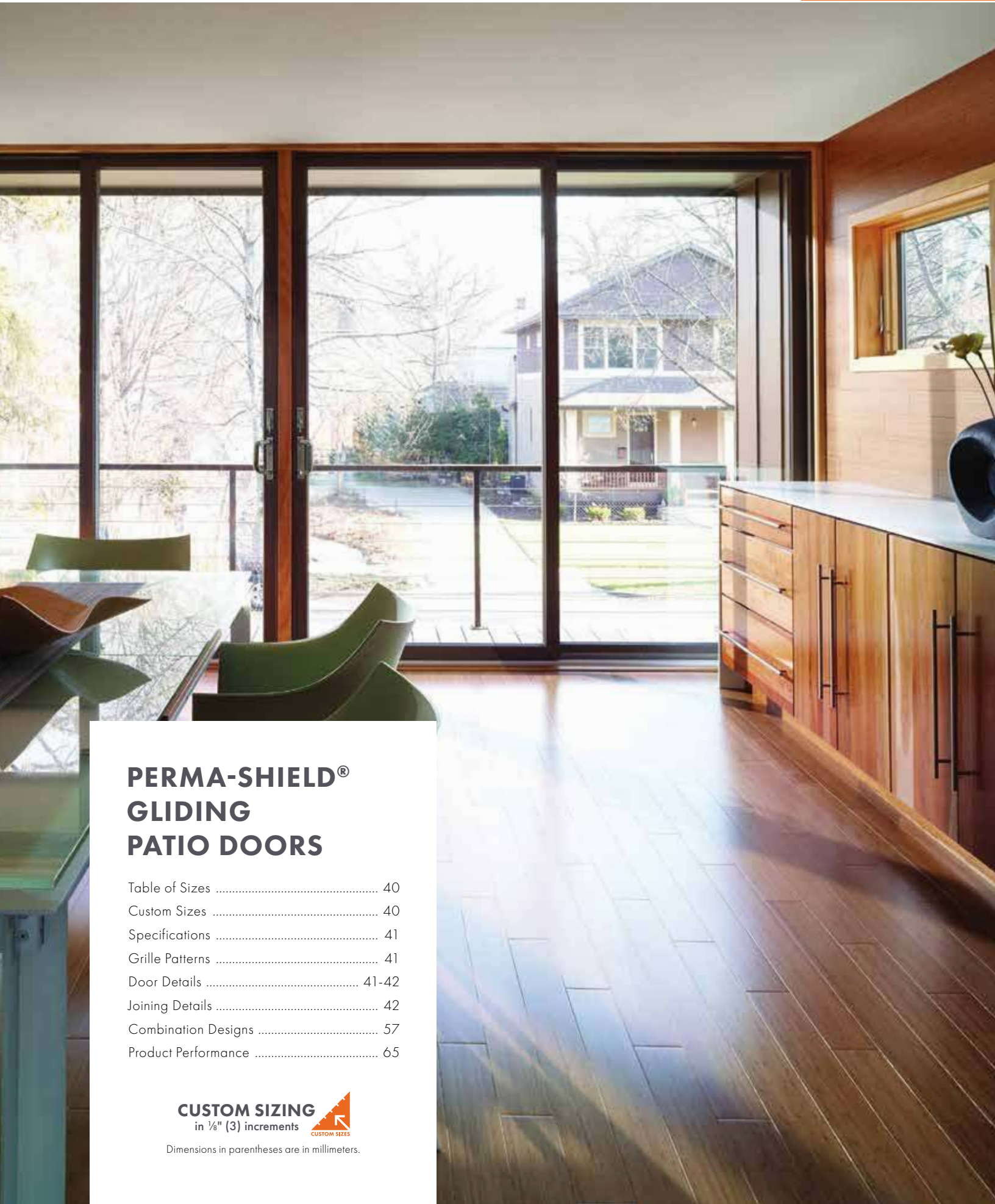

PERMA-SHIELD® GLIDING PATIO DOORS

- Table of Sizes 40
- Custom Sizes 40
- Specifications 41
- Grille Patterns 41
- Door Details 41-42
- Joining Details 42
- Combination Designs 57
- Product Performance 65

CUSTOM SIZING
in 1/8" (3) increments 
CUSTOM SIZES

Dimensions in parentheses are in millimeters.

PERMA-SHIELD® GLIDING PATIO DOORS

FEATURES

FRAME

A All basic exterior frame members are covered with a Perma-Shield® rigid vinyl cladding that maintains an attractive appearance while minimizing maintenance.

B Wood frame members are treated with a water-repellent preservative for long-lasting protection and performance.

Factory-assembled two-panel doors are available and arrive at the job site ready to install. Unassembled doors are also available and require job site assembly.

C A flexible vinyl weatherstrip on the head and side jambs provides a positive seal between the frame and panels.

SILL

D The sill has an anodized aluminum track with a stainless steel cap that resists stains, rust and denting. A thermal barrier reduces conductive heat loss and limits condensation on the inside.

PANEL

E All panel surfaces are covered with a Perma-Shield® rigid vinyl cladding that maintains an attractive appearance while minimizing maintenance.

F Laminated veneer lumber panels provide excellent structural stability and energy efficiency.

Dual rollers on the door panels provide smooth gliding operation with self-contained leveling adjusters.

Flexible Seal



A full-length combination weatherstrip/interlock system provides a flexible seal at the meeting stile.



GLASS

G Glass spacers are available in black or stainless steel.

H A high-performing thermoplastic glazing bead features a flexible lip that provides superior weathertightness and long-term durability.

I Dual-pane glass options include:

- Low-E tempered glass
- Low-E HeatLock® tempered glass
- Low-E SmartSun™ tempered glass
- Low-E SmartSun HeatLock tempered glass
- Low-E Sun tempered glass
- Clear dual-pane tempered glass

For even greater energy performance, 1" (25) triple-pane glass is available in these options:

- Low-E tempered glass
- Low-E Enhanced tempered glass
- Low-E Enhanced HeatLock tempered glass
- Low-E SmartSun tempered glass
- Low-E SmartSun Enhanced tempered glass
- Low-E SmartSun Enhanced HeatLock tempered glass

Additional glass options are available. Contact your Andersen supplier.

A removable translucent film helps shield the glass from damage during delivery and construction, and simplifies finishing at the job site.

EXTERIORS & INTERIORS

EXTERIOR & INTERIOR COLORS



Interior color will match the exterior color selected.

HARDWARE Sold Separately



Bold name denotes finish shown.

HARDWARE FINISHES

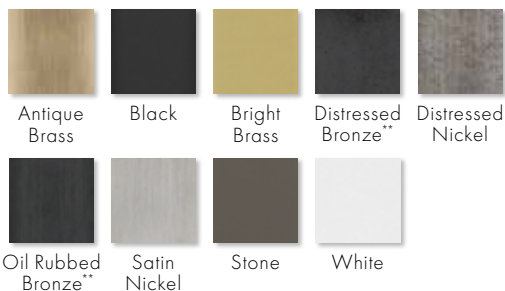

*Visit andersenwindows.com/warranty for details.

**These finishes are "living finishes" that will change with time and use, see limited warranty for details.

Andersen patio doors are not intended for use as entry doors.

Mix-and-match interior and exterior style and finish hardware options are available.

Bright brass and satin nickel finishes on patio door hardware are a PVD finish and feature a 10-year limited warranty.

Albany and Tribeca hardware are zinc die cast with durable powder-coated finish. Other hardware is solid forged brass.

Printing limitations prevent exact replication of colors and finishes. See your Andersen supplier for actual color and finish samples.

Dimensions in parentheses are in millimeters.

Blinds-Between-the-Glass

Blinds-between-the-glass are available for select gliding patio door sizes when ordered with Low-E tempered glass. White 1/2" (13) aluminum slat blinds come mounted between two panes of insulated glass. Blinds are magnetically controlled, and can be tilted, raised and lowered using low-profile controls. Available in 33611, 5068, 51168 and 61611 door sizes. Contact your Andersen supplier for more information.

HARDWARE
Reachout Locking Hardware

The unique Andersen® reachout locking hardware pulls the door panel snugly into the jamb for a weather tight seal and enhanced security.

PERFORMANCE OPTIONS
Performance Grade (PG) Upgrade

PG upgrade is available for select sizes of standard non-impact Perma-Shield® gliding patio doors. Heavy-duty rollers and reinforced frame and panel components allow these units to achieve higher performance ratings. PG upgrade ratings are more comprehensive than Design Pressure (DP) ratings for measuring product performance. For up-to-date performance information of individual products, visit andersenwindows.com.

ACCESSORIES Sold Separately

FRAME
Extension Jamb

Standard jamb depth is 4 9/16" (116). Pine, maple and oak veneers or prefinished white interior extension jambs are available in 1/16" (1.5) increments between 5 1/16" (129) and 7 1/8" (181).

Threshold

A maple or oak threshold is available for finishing the interior of the sill.

Ramped Sill Insert

Ramped sills in maple or oak provide a smooth transition from interior to exterior, and can be used with a retractable insect screen but not a gliding insect screen. Check with local and federal officials to determine if product meets accessibility codes. Shown with an Andersen 400 Series Frenchwood® gliding patio door.

Sill Support

An aluminum sill support is designed to lock into a channel under the sill and tie back into the wall. This will offer support to the outermost sill section when needed. Available in a neutral gray finish.

HARDWARE
Exterior Keyed Lock



A six-pin key cylinder lock allows the door to be locked and unlocked from the exterior. Available in finishes that coordinate with the hardware.

Auxiliary Foot Lock

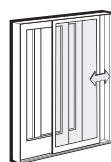

Provides an extra measure of security when the door is in a locked position. The lock can be set so the door is fully closed or partially open to provide a secure venting position. Available in all hardware finishes.

INSECT SCREENS

Screens have a long-lasting fiberglass screen mesh with a charcoal gray finish. Frames are color matched to the exterior of the door.

Gliding Screen

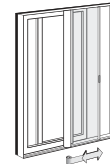
Patented square-corner joint construction adds considerable strength to the frame members. Gliding screens have Delrin® injection-molded bottom rollers with self-contained leveling adjusters, providing smooth operation. Interior and exterior pulls and latch are provided.

Retractable Screen

Our premium retractable screen for has an integrated design, allowing it to glide side to side across the width of the opening and disappear when not in use. The screen features high-weather and retention performance, tear-resistant screen mesh, and quality metal hardware, along with an owner-to-owner 10-year limited warranty. Available in all exterior colors.

GRILLES

Grilles are available in a variety of configurations and widths. See page 15 for details.

EXTERIOR TRIM

Available with Andersen exterior trim. See the Exterior Trim section starting on page 51.

SIDELIGHTS

Stationary units can be selected for use as sidelights. See the size table on page 40 for size options.

CAUTION: Painting and staining may cause damage to rigid vinyl. Andersen does not warrant the adhesion or performance of homeowner-applied paint over vinyl or other factory-coated surfaces. For vinyl painting instructions and preparation, contact your Andersen supplier. Do not paint weatherstrip. Creosote-based stains should not come in contact with Andersen products. Abrasive cleaners or solutions containing corrosive solvents should not be used on Andersen products.

*Visit andersenwindows.com/warranty for details.

"Delrin" is a registered trademark of E.I. du Pont de Nemours and Company.

Andersen patio doors are not intended for use as entry doors.

Dimensions in parentheses are in millimeters.

PERMA-SHIELD® GLIDING PATIO DOORS

Table of Perma-Shield® Gliding Patio Door Sizes

Scale 1/8" (3) = 1'-0" (305) – 1:96

Door Dimension	4'-11 1/4" (1505)	4'-11 1/4" (1505)	5'-10 1/2" (1791)	5'-10 1/2" (1791)
Minimum Rough Opening	5'-0" (1524)	5'-0" (1524)	5'-11 1/4" (1810)	5'-11 1/4" (1810)
Unobstructed Glass (single panel only)	24 3/4" (629)	24 3/4" (629)	30 3/8" (772)	30 3/8" (772)

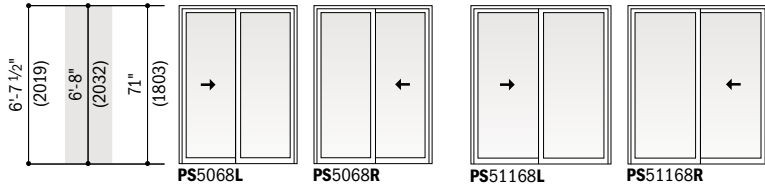

Door Dimension	3'-2 3/8" (975)	6'-0" (1829)	6'-0" (1829)	4'-2 3/8" (1280)	8'-0" (2438)	8'-0" (2438)
Minimum Rough Opening	3'-3 1/8" (994)	6'-0 3/4" (1848)	6'-0 3/4" (1848)	4'-3 1/8" (1299)	8'-0 3/4" (2457)	8'-0 3/4" (2457)
Unobstructed Glass (single panel only)	31 1/8" (791)	31 1/8" (791)	31 1/8" (791)	43 1/8" (1095)	43 1/8" (1095)	43 1/8" (1095)

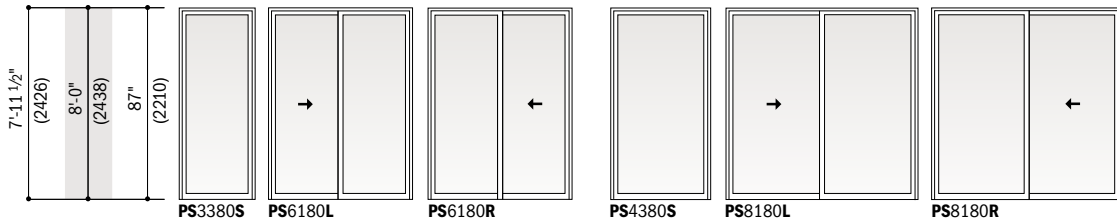
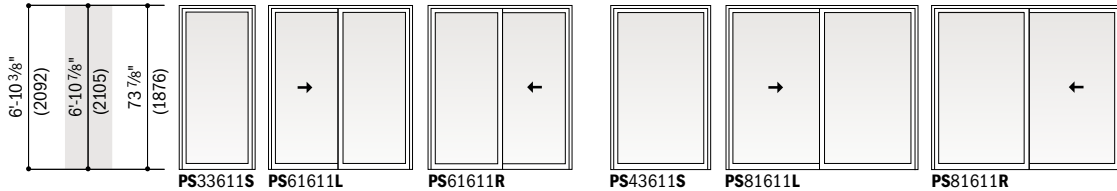

Custom-size doors are available in 1/8" (3) increments. See below for custom sizes and specifications.

Viewed from the exterior. Arrow indicates direction of panel operation. Stationary (S) doors can be used as an individual unit or as a sidelight.

Grille patterns shown on page 41. Details shown on pages 41-42.

- Door Dimension always refers to outside frame-to-frame dimension.
- **Minimum Rough Opening dimensions may need to be increased to allow for use of building wraps, flashing, sill panning, brackets, fasteners or other items. See page 74 for more details.**
- Dimensions in parentheses are in millimeters.
- For doors with blinds-between-the-glass, unobstructed glass width dimension is reduced.

Custom Sizes and Specification Formulas

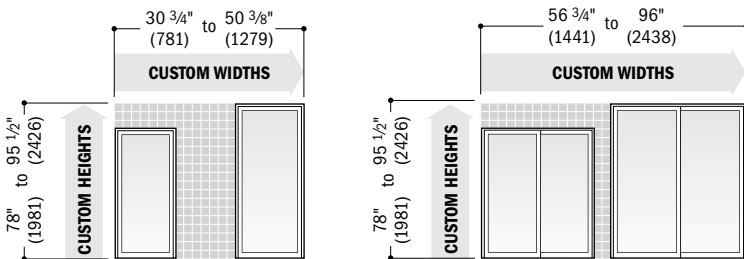

Available in 1/8" (3) increments between minimum and maximum widths and heights shown. Some restrictions apply. Measurement guide can be found at andersenwindows.com/measure.

Clear Opening 	Two-Panel Width = width + 2" - 7.5" (191) Height = height - 4.155" (106)	Minimum R.O. 	Width = width + 3/4" (19) Height = height + 1/2" (13)	Unobst. Glass 	Single-Panel Width = width - 7.25" (184) Height = height - 8.562" (217)
	Two-Panel Width = width - 9.75" (248) Height = height - 8.562" (217)				

- **Clear Opening** formulas provide dimensions for determining area available for egress. Vent opening, or area available for passage of air, is equal to clear opening. **Minimum R.O.** (minimum rough opening) formulas provide minimum rough opening width and height dimensions. **Unobst. Glass** (unobstructed glass) formulas provide dimensions for determining area available for passage of light.
- Dimensions in parentheses are in millimeters.

Order Designation Descriptions

Viewed from the exterior.

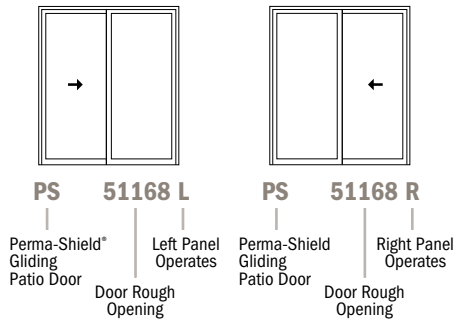

Two-Panel Perma-Shield® Gliding Patio Door Opening and Area Specifications

Door Number	Clear Opening Area Sq. Ft./ (m ²)	Clear Opening in Full Open Position		Glass Area Sq. Ft./ (m ²)	Vent Area Sq. Ft./ (m ²)	Overall Door Area Sq. Ft./ (m ²)
		Width Inches/ (mm)	Height Inches/ (mm)			
PS5068	11.64 (1.08)	22 1/8" (562)	75 3/4" (1924)	24.90 (2.31)	11.64 (1.08)	32.71 (3.04)
PS51168	14.60 (1.36)	27 3/4" (705)	75 3/4" (1924)	30.40 (2.82)	14.60 (1.36)	38.92 (3.62)
PS61611	15.56 (1.45)	28 1/2" (724)	78 5/8" (1997)	32.40 (3.01)	15.56 (1.45)	41.19 (3.83)
PS81611	22.11 (2.05)	40 1/2" (1029)	78 5/8" (1997)	44.20 (4.11)	22.11 (2.05)	54.92 (5.10)
PS6180	18.16 (1.69)	28 1/2" (724)	91 3/4" (2330)	37.60 (3.49)	18.16 (1.69)	47.75 (4.44)
PS8180	25.80 (2.40)	40 1/2" (1029)	91 3/4" (2330)	52.10 (4.84)	25.80 (2.40)	63.67 (5.92)

*Dimensions in parentheses are in millimeters or square meters.

Stationary Perma-Shield® Gliding Patio Door Area Specifications

Door Number	Glass Area Sq. Ft./ (m ²)	Overall Door Area Sq. Ft./ (m ²)
PS33611	16.00 (1.49)	21.95 (2.04)
PS43611	22.10 (2.05)	28.82 (2.68)
PS3380	19.71 (1.83)	25.45 (2.36)
PS4380	27.04 (2.51)	29.35 (2.73)

*Dimensions in parentheses are in square meters.

Grille Patterns

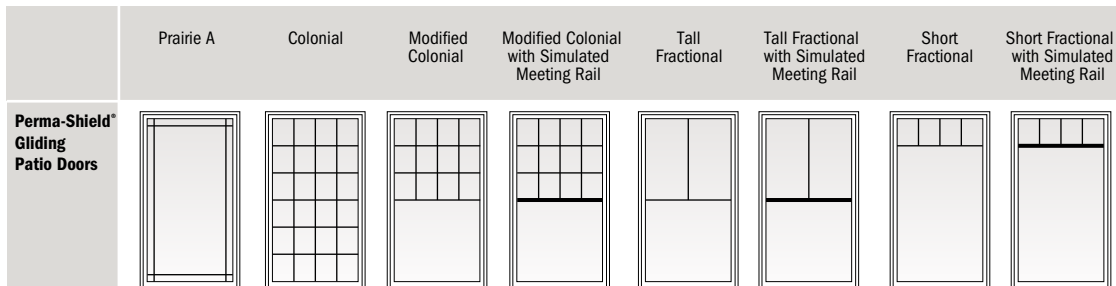

Number of lights and overall pattern varies with door size. Patterns may not be available in all configurations or sizes. Specified equal light and custom patterns are also available. For more grille options, see page 15 or visit andersenwindows.com/grilles.

200 Series Perma-Shield® Gliding Patio Doors

Perma-Shield® Gliding Patio Door Details

Scale 1 1/2" (38) = 1'-0" (305) – 1:8

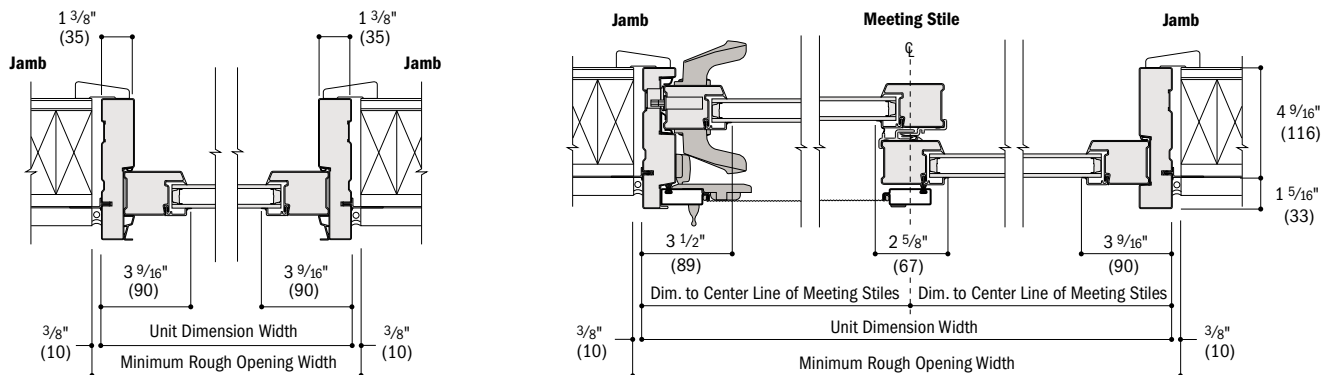

Horizontal Section
Stationary

Horizontal Section
Two-Panel

continued on next page

- *Light-colored areas are parts included with door. Dark-colored areas are additional Andersen® parts required to complete door assembly as shown.
- *Minimum rough openings may need to be increased to allow for use of building wraps, flashing, sill panning, brackets, fasteners or other items. See installation information on page 74.
- *Details are for illustration only and are not intended to represent product installation methods or materials. Refer to product installation guides at andersenwindows.com.
- *Dimensions in parentheses are in millimeters.

PERMA-SHIELD® GLIDING PATIO DOORS

Perma-Shield® Gliding Patio Door Details (continued)

Scale 1 1/2" (38) = 1'-0" (305) – 1:8

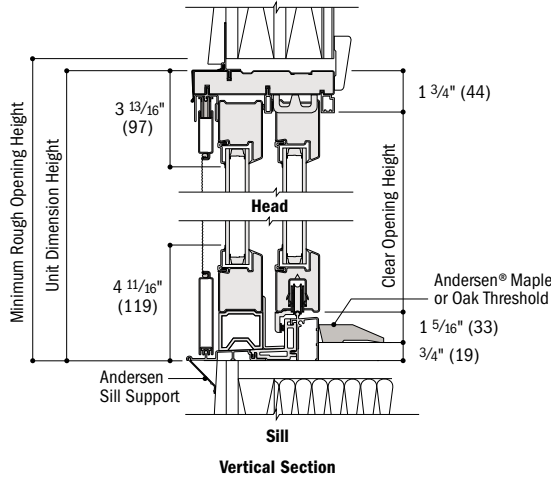
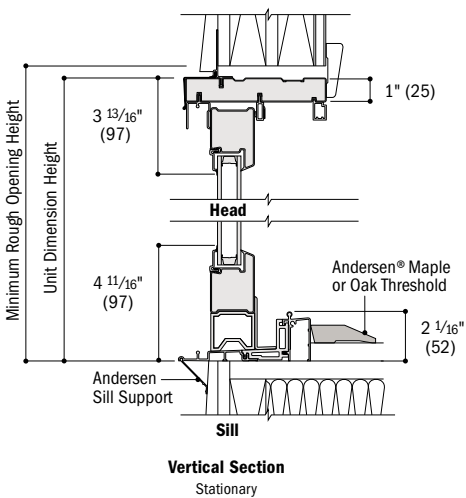

Vertical Joining Detail – Jamb-to-Jamb

Scale 1 1/2" (38) = 1'-0" (305) – 1:8

Overall Door Dimension Width

Sum of individual door widths plus 1/16" (1.5) per join.

Overall Minimum Rough Opening Width

Overall door width plus 3/4" (19).

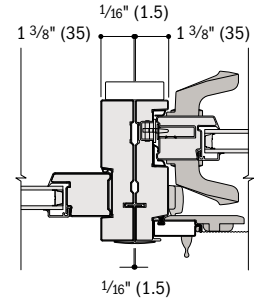

Perma-Shield® Gliding to Perma-Shield® Gliding

Clear Opening Details

Scale 1 1/2" (38) = 1'-0" (305) – 1:8

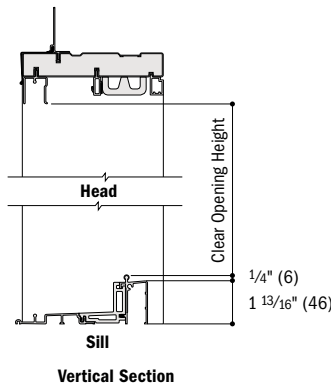
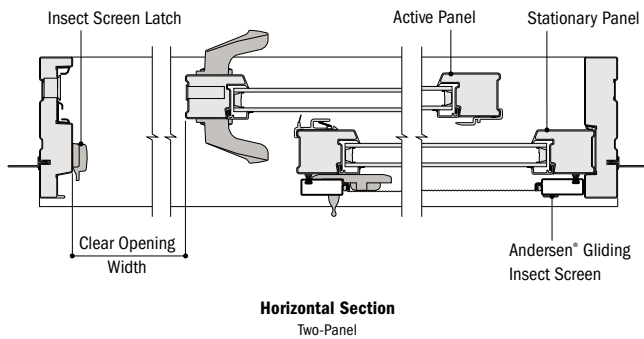

Vertical Joining Detail – Fiberglass

Scale 1 1/2" (38) = 1'-0" (305) – 1:8

Overall Door Dimension Width

Sum of individual door widths plus 3/4" (19) per join.

Overall Minimum Rough Opening Width

Overall door width plus 3/4" (19).

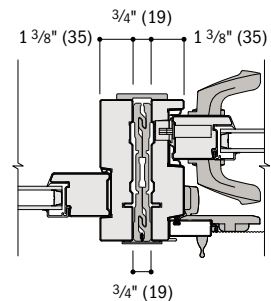

Perma-Shield® Gliding to Perma-Shield® Gliding

Ramped Sill Detail

Scale 1 1/2" (38) = 1'-0" (305) – 1:8

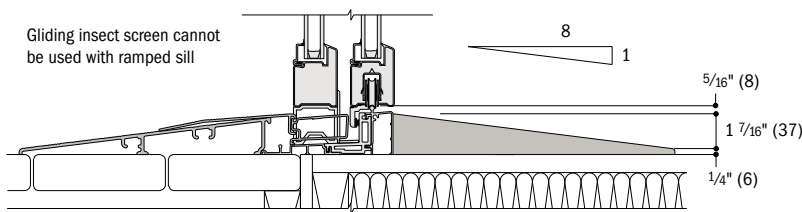

Vertical Section

Andersen does not recommend joining of receiver jamb to receiver jamb. For more information on joining, refer to the Combination Designs section starting on page 57.

- Light-colored areas are parts included with door. Dark-colored areas are additional Andersen® parts required to complete door assembly as shown.
- **Minimum rough openings may need to be increased to allow for use of building wraps, flashing, sill panning, brackets, fasteners or other items. See installation information on page 74.**
- Details are for illustration only and are not intended to represent product installation methods or materials. Refer to product installation instructions at andersenwindows.com.
- Structural performance of any combination is only as high as the lowest structural performance of any individual product or join in the combination.
- Andersen recommends installation of doors into separate rough openings. Consult with an architect or structural engineer regarding minimum requirements for structural support members between adjacent rough openings.
- Dimensions in parentheses are in millimeters.

Separate Rough Openings Detail

Scale 1 1/2" (38) = 1'-0" (305) – 1:8

To meet structural requirements or to achieve a wider joined appearance, doors may be installed into separate rough openings having vertical support by others in combination with Andersen® exterior filler and exterior vinyl trim.

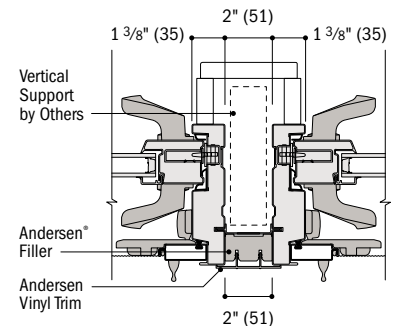

Perma-Shield® Gliding and Perma-Shield® Gliding



HINGED INSWING PATIO DOORS

- Table of Sizes 46-47
- Specifications 48
- Grille Patterns 49
- Door Details 49-50
- Joining Details 50
- Combination Designs 57
- Product Performance 65

HINGED INSWING PATIO DOORS

FEATURES

FRAME

- A** The exterior frame is clad with aluminum that maintains an attractive appearance while minimizing maintenance.
- B** A preservative-treated wood subframe with a frame end protector at the sill resists rot, and provides long-lasting protection and performance.
- The frame is predrilled for convenient installation. Specially designed plugs cover the installation screws for a clean appearance.
- C** Durable rubberized Santoprene® gasket-type weatherstrip is applied to the sides and head jamb of the frame and engages when the door panel is closed, providing effective protection against water and air infiltration.



Choose either a 6¹/₁₆" (167), shown below left, or a 4¹/₁₆" (116) jamb depth, shown below right.



SILL

- D** A unique anodized aluminum sill design controls water and helps funnel it away from the door to minimize water infiltration. Also available with an optional bronze anodized sill.
- E** A unique sweep/sill interface completes the perimeter protection and allows for easier operation of the door, limiting weatherstrip friction between the sweep and sill.

PANEL

- F** A durable, low-maintenance interior and exterior resists weather and rot. Sturdy fiberglass construction provides long-lasting performance. The insulated bottom rail enhances energy efficiency.



- G** Unique corner keys allow for tight, attractive corners.
- H** Traditional door styling features a tall bottom rail and wide stiles. The panel is built to tolerances within 1/32" (1) for smooth operation and maximum durability.

Adjustable Hinges

Adjustable hinges help provide a weathertight seal and smooth operation. Available in antique brass, bright brass, oil rubbed bronze, satin nickel and white.



GLASS

- I** Glass spacers are available in black or stainless steel.
- J** Panels are silicone bed glazed and finished with an interior wood stop.
- K** Dual-pane glass options include:
- Low-E tempered glass
 - Low-E HeatLock® tempered glass
 - Low-E SmartSun™ tempered glass
 - Low-E SmartSun HeatLock tempered glass
 - Low-E Sun tempered glass
 - Clear dual-pane tempered glass

Additional glass options are available. Contact your Andersen supplier.

A removable translucent film helps shield the glass from damage during delivery and construction, and simplifies finishing at the job site.

EXTERIORS & INTERIORS

EXTERIOR COLORS



INTERIOR COLOR

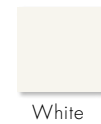

ANDERSEN® HARDWARE Sold Separately



Bold name denotes finish shown.

HARDWARE FINISHES



DESIGNER HARDWARE Sold Separately

See pages 12-13 for designer hinged patio door hardware options.

In addition to Andersen hardware, Andersen also offers Ashley Norton®, Baldwin®, and FSB® designer hardware, which is available in an extensive variety of styles and finishes for hinged patio doors.

*Visit andersenwindows.com/warranty for details.

**These finishes are "living finishes" that will change with time and use, see limited warranty for details.

Andersen patio doors are not intended for use as entry doors.

Mix-and-match interior and exterior style and finish options are available.

Bright brass and satin nickel finishes on patio door hardware are a PVD finish and feature a 10-year limited warranty.

Albany and Tribeca hardware are zinc die cast with durable powder-coated finish. Other hardware is solid forged brass.

All trademarks where denoted are marks of their respective owners.

Printing limitations prevent exact replication of colors and finishes. See your Andersen supplier for actual color and finish samples.

Dimensions in parentheses are in millimeters.

HARDWARE
Locking System

A hook deadbolt lock comes pre-installed, reducing installation time. The mortised lock and hook design provides strength and added security compared to bored locks with standard deadbolts.

Multi-point locks are standard on 7'-6" (2286) and 8'-0" (2438) height patio doors. Multi-point locks can be ordered for 6'-8" (2032) and 6'-11" (2108) patio doors as an option. Contact your Andersen supplier for availability.

OPTIONAL LOW-THRESHOLD ACCESSIBLE DOOR

Andersen offers a single-panel accessible door that is 3'-2 1/8" (968) wide with a 10 1/4" (260)-high bottom rail and a 1/2" (13)-high low-threshold sill. The low threshold sill is only available in a bronze anodized finish and is not available for other door widths.

ACCESSORIES Sold Separately

FRAME
Extension Jamb

Standard jamb depth is 4 9/16" (116). A 6 9/16" (167) jamb depth is also available. Prefinished white interior extension jambs are available in 1/16" (1.5) increments between 5 1/16" (129) and 7 1/8" (181).

Interior extension jambs on inswing units will restrict the full opening of the door. These extension jambs can also be added to 6 9/16" (167) jambs.

HARDWARE
Exterior Keyed Lock

A six-pin keyed cylinder lock is available in styles and finishes that coordinate with Andersen® door hardware. This lock allows the hinged patio door to be locked and unlocked from the exterior.

Strike Plate Extension

Antique brass, bright brass, oil rubbed bronze and satin nickel strike plate extensions are available for 5 1/4" (133), 6 9/16" (167) and 7 1/8" (181) wall depths.

Handle Extension



Extends interior door handle an additional 1" (25) from the door interior panel to accommodate blinds or shades. Kit includes one handle extender and spindle. A second extender may be added to the spindle to increase the length an additional 1" (25) to a 2" (51) total extension. Extenders are available in finishes that coordinate with Andersen door hardware.

Construction Lock

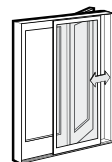

This hardware can be used to help secure the structure during the construction phase of the project. It features an undersized escutcheon plate, which makes on-site finishing easier. Shown on a 400 Series Frenchwood® hinged patio door.

INSECT SCREENS

Screens have a long-lasting fiberglass screen mesh with a charcoal gray finish. Frames are color matched to the exterior of the door.

Gliding Screen

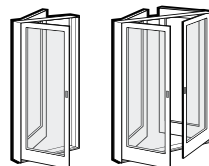
Available for two-panel doors when only one panel opens. Features Delrin® material injection-molded bottom rollers with self-contained leveling adjusters.

Hinged Screens

Available for single-panel doors and two-panel doors when both panels open.

GRILLES

Available in a variety of configurations and widths. See page 15 for details.

EXTERIOR TRIM

Available with Andersen exterior trim. See the Exterior Trim section starting on page 51.

SIDELIGHTS

Stationary units can also be selected for use as sidelights. See the size table on page 46 for size options.

CAUTION: Painting and staining may cause damage to rigid vinyl. Andersen does not warrant the adhesion or performance of homeowner-applied paint over vinyl or other factory-coated surfaces. For vinyl painting instructions and preparation, contact your Andersen supplier. Do not paint weatherstrip. Creosote-based stains should not come in contact with Andersen products. Abrasive cleaners or solutions containing corrosive solvents should not be used on Andersen products.

*Visit andersenwindows.com/warranty for details.

"Delrin" is a registered trademark of E.I. du Pont de Nemours and Company.











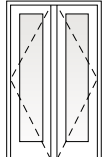
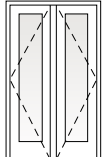

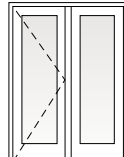
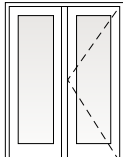
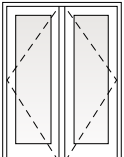
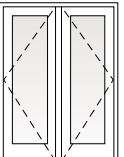

Andersen patio doors are not intended for use as entry doors.

Dimensions in parentheses are in millimeters.

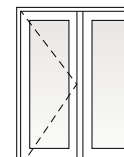
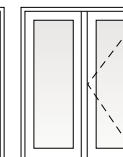
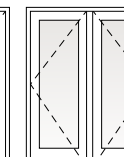
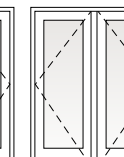
HINGED INSWING PATIO DOORS

Table of Hinged Inswing Patio Door Sizes

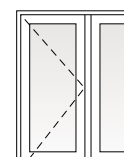
Scale 1/8" (3) = 1'-0" (305) – 1:96

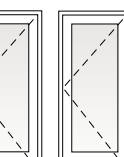
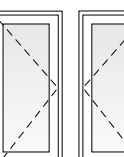
Door Dimension	2'-0 1/2" (620)		4'-0" (1219)		4'-0" (1219)		
Minimum Rough Opening	2'-1" (634)		4'-1" (1242)		4'-1" (1242)		
Unobstructed Glass (single panel only)	13 1/4" (336)		13 1/4" (336)		13 1/4" (336)		
4 heights	 <ol style="list-style-type: none"> 1 ISPD2168S 2 ISPD21611S 3 ISPD2176S 4 ISPD2180S 		 <ol style="list-style-type: none"> 1 ISPD4168APLR 2 ISPD41611APLR 3 ISPD4176APLR 4 ISPD4180APLR 		 <ol style="list-style-type: none"> 1 ISPD4168PALR 2 ISPD41611PALR 3 ISPD4176PALR 4 ISPD4180PALR 		
Door Dimension	2'-6 1/8" (765)	2'-6 1/8" (765)	2'-6 1/8" (765)	4'-11 1/4" (1504)	4'-11 1/4" (1504)	4'-11 1/4" (1504)	4'-11 1/4" (1504)
Minimum Rough Opening	2'-7" (787)	2'-7" (787)	2'-7" (787)	5'-0" (1524)	5'-0" (1524)	5'-0" (1524)	5'-0" (1524)
Unobstructed Glass (single panel only)	18 7/8" (479)	18 7/8" (479)	18 7/8" (479)	18 7/8" (479)	18 7/8" (479)	18 7/8" (479)	18 7/8" (479)
4 heights	 <ol style="list-style-type: none"> 1 ISPD2768S 2 ISPD27611S 3 ISPD2776S 4 ISPD2780S 	 <ol style="list-style-type: none"> 1 ISPD2768AR 2 ISPD27611AR 3 ISPD2776AR 4 ISPD2780AR 	 <ol style="list-style-type: none"> 1 ISPD2768AL 2 ISPD27611AL 3 ISPD2776AL 4 ISPD2780AL 	 <ol style="list-style-type: none"> 1 ISPD5068ASR 2 ISPD50611ASR 3 ISPD5076ASR 4 ISPD5080ASR 	 <ol style="list-style-type: none"> 1 ISPD5068SAL 2 ISPD50611SAL 3 ISPD5076SAL 4 ISPD5080SAL 	 <ol style="list-style-type: none"> 1 ISPD5068APLR 2 ISPD50611APLR 3 ISPD5076APLR 4 ISPD5080APLR 	 <ol style="list-style-type: none"> 1 ISPD5068PALR 2 ISPD50611PALR 3 ISPD5076PALR 4 ISPD5080PALR
Door Dimension	2'-8 1/8" (816)	2'-8 1/8" (816)	2'-8 1/8" (816)	5'-3 1/4" (1607)	5'-3 1/4" (1607)	5'-3 1/4" (1607)	5'-3 1/4" (1607)
Minimum Rough Opening	2'-9" (838)	2'-9" (838)	2'-9" (838)	5'-4" (1626)	5'-4" (1626)	5'-4" (1626)	5'-4" (1626)
Unobstructed Glass (single panel only)	20 7/8" (530)	20 7/8" (530)	20 7/8" (530)	20 7/8" (530)	20 7/8" (530)	20 7/8" (530)	20 7/8" (530)
4 heights	 <ol style="list-style-type: none"> 1 ISPD2968S 2 ISPD29611S 3 ISPD2976S 4 ISPD2980S 	 <ol style="list-style-type: none"> 1 ISPD2968AR 2 ISPD29611AR 3 ISPD2976AR 4 ISPD2980AR 	 <ol style="list-style-type: none"> 1 ISPD2968AL 2 ISPD29611AL 3 ISPD2976AL 4 ISPD2980AL 	 <ol style="list-style-type: none"> 1 ISPD5468ASR 2 ISPD54611ASR 3 ISPD5476ASR 4 ISPD5480ASR 	 <ol style="list-style-type: none"> 1 ISPD5468SAL 2 ISPD54611SAL 3 ISPD5476SAL 4 ISPD5480SAL 	 <ol style="list-style-type: none"> 1 ISPD5468APLR 2 ISPD54611APLR 3 ISPD5476APLR 4 ISPD5480APLR 	 <ol style="list-style-type: none"> 1 ISPD5468PALR 2 ISPD54611PALR 3 ISPD5476PALR 4 ISPD5480PALR
Door Dimension	3'-0 1/8" (918)	3'-0 1/8" (918)	3'-0 1/8" (918)	5'-11 1/4" (1810)	5'-11 1/4" (1810)	5'-11 1/4" (1810)	5'-11 1/4" (1810)
Minimum Rough Opening	3'-1" (940)	3'-1" (940)	3'-1" (940)	6'-0" (1829)	6'-0" (1829)	6'-0" (1829)	6'-0" (1829)
Unobstructed Glass (single panel only)	24 7/8" (632)	24 7/8" (632)	24 7/8" (632)	24 7/8" (632)	24 7/8" (632)	24 7/8" (632)	24 7/8" (632)
4 heights	 <ol style="list-style-type: none"> 1 ISPD3168S 2 ISPD31611S 3 ISPD3176S 4 ISPD3180S 	 <ol style="list-style-type: none"> 1 ISPD3168AR 2 ISPD31611AR 3 ISPD3176AR 4 ISPD3180AR 	 <ol style="list-style-type: none"> 1 ISPD3168AL 2 ISPD31611AL 3 ISPD3176AL 4 ISPD3180AL 	 <ol style="list-style-type: none"> 1 ISPD6068ASR 2 ISPD60611ASR 3 ISPD6076ASR 4 ISPD6080ASR 	 <ol style="list-style-type: none"> 1 ISPD6068SAL 2 ISPD60611SAL 3 ISPD6076SAL 4 ISPD6080SAL 	 <ol style="list-style-type: none"> 1 ISPD6068APLR 2 ISPD60611APLR 3 ISPD6076APLR 4 ISPD6080APLR 	 <ol style="list-style-type: none"> 1 ISPD6068PALR 2 ISPD60611PALR 3 ISPD6076PALR 4 ISPD6080PALR

Stationary (S) doors can be used as an individual unit or as a sidelight.

Grille patterns shown on page 49.

Details shown on pages 49-50.

- Door Dimension always refers to outside frame-to-frame dimension.
- **Minimum Rough Opening** dimensions may need to be increased to allow for use of building wraps, flashing, sill panning, brackets, fasteners or other items. See page 74 for more details.
- Dimensions in parentheses are in millimeters.

Patio Door Heights

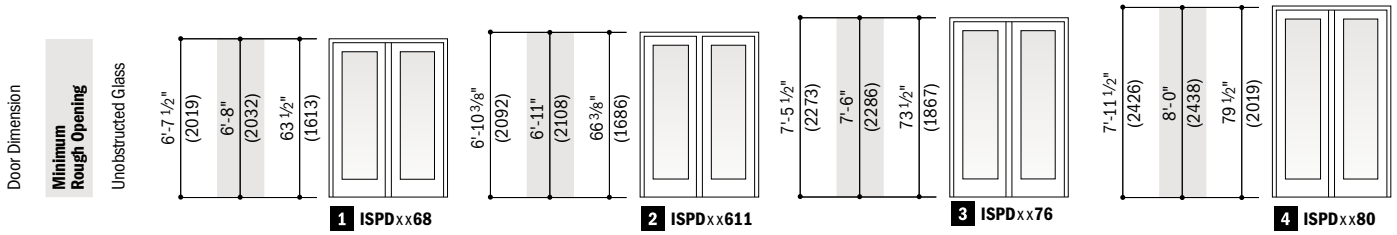

Door Dimension	3'-2 1/8" (968)	3'-2 1/8" (968)
Minimum Rough Opening	3'-3" (991)	3'-3" (991)
Unobstructed Glass (single panel only)	26 7/8" (683)	26 7/8" (683)

Accessibility Width Patio Door Also Available

For easier access, this single panel door offers a 32" (813) clear opening width when the panel is open 90°; a 1/2" (13) threshold and a bottom rail height of 10 1/4" (260). This door has a limited water rating (LW) due to the low-threshold sill.

1 ISPD33611AR

2 ISPD3376AR

3 ISPD3380AR

ISPD33611AL

ISPD3376AL

ISPD3380AL

Order Designation Descriptions

Viewed from the exterior.

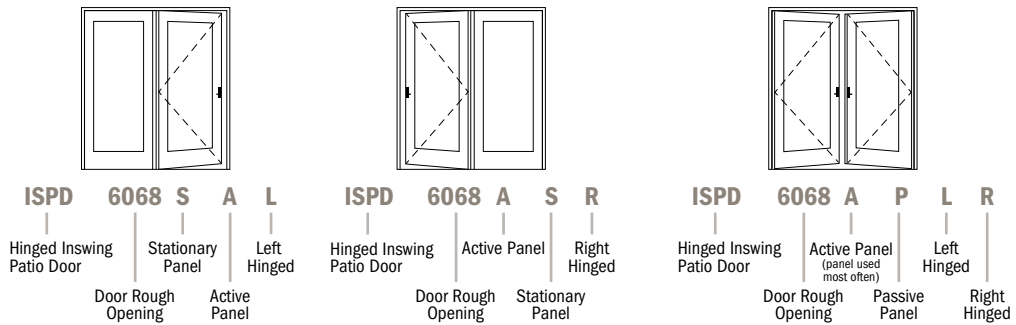

• Door Dimension always refers to outside frame-to-frame dimension.
 • Minimum Rough Opening dimensions may need to be increased to allow for use of building wraps, flashing, sill panning, brackets, fasteners or other items. See page 74 for more details.
 • Dimensions in parentheses are in millimeters.

HINGED INSWING PATIO DOORS

Hinged Inswing Patio Door Opening and Area Specifications

Door Number	Number of Panels in Open Position*	Clear Opening Area Sq. Ft./ (m ²)	Clear Opening Maximums			Glass Area Sq. Ft./ (m ²)	Vent Area Sq. Ft./ (m ²)	Overall Door Area Sq. Ft./ (m ²)
			90° Open Position Width Inches/(mm)	Full Open Position Width Inches/(mm)	Height Inches/(mm)			
ISPD2768	1	13.52 (1.26)	25 3/8" (644)	27 9/16" (701)	76 3/4" (1949)	8.32 (0.77)	13.52 (1.26)	16.61 (1.54)
ISPD2968	1	14.58 (1.36)	27 3/8" (695)	29 9/16" (752)	76 3/4" (1949)	9.20 (0.85)	14.58 (1.36)	17.72 (1.65)
ISPD3168	1	16.71 (1.55)	31 3/8" (797)	33 9/16" (853)	76 3/4" (1949)	10.96 (1.02)	16.71 (1.55)	19.93 (1.85)
ISPD4168	2	21.87 (2.03)	41" (1042)	45 1/2" (1156)	76 3/4" (1949)	11.67 (1.08)	21.87 (2.03)	26.50 (2.46)
ISPD4168	1	10.52 (0.98)	19 3/4" (501)	21 15/16" (558)	76 3/4" (1949)	11.67 (1.08)	10.52 (0.98)	26.50 (2.46)
ISPD5068	2	27.87 (2.59)	52 1/4" (1328)	56 3/4" (1441)	76 3/4" (1949)	16.63 (1.55)	27.87 (2.59)	32.71 (3.04)
ISPD5068	1	13.52 (1.26)	25 3/8" (644)	27 9/16" (701)	76 3/4" (1949)	16.63 (1.55)	13.52 (1.26)	32.71 (3.04)
ISPD5468	2	30.00 (2.79)	56 1/4" (1430)	60 3/4" (1543)	76 3/4" (1949)	18.39 (1.71)	30.00 (2.79)	34.92 (3.24)
ISPD5468	1	14.58 (1.36)	27 3/8" (695)	29 9/16" (752)	76 3/4" (1949)	18.39 (1.71)	14.58 (1.36)	34.92 (3.24)
ISPD6068	2	34.26 (3.18)	64 1/4" (1633)	68 3/4" (1746)	76 3/4" (1949)	21.92 (2.04)	34.26 (3.18)	39.34 (3.65)
ISPD6068	1	16.71 (1.55)	31 3/8" (797)	33 9/16" (853)	76 3/4" (1949)	21.92 (2.04)	16.71 (1.55)	39.34 (3.65)
ISPD27611	1	14.02 (1.30)	25 3/8" (644)	27 9/16" (701)	79 5/8" (2022)	8.69 (0.81)	14.02 (1.30)	17.21 (1.60)
ISPD29611	1	15.13 (1.41)	27 3/8" (695)	29 9/16" (752)	79 5/8" (2022)	9.61 (0.89)	15.13 (1.41)	18.36 (1.71)
ISPD31611	1	17.34 (1.61)	31 3/8" (797)	33 9/16" (853)	79 5/8" (2022)	11.45 (1.06)	17.34 (1.61)	20.65 (1.92)
ISPD33611**	1	18.68 (1.74)	33 3/8" (847)	35 9/16" (904)	80 5/8" (2048)	11.45 (1.06)	18.68 (1.74)	21.79 (2.03)
ISPD41611	2	22.69 (2.11)	41" (1042)	45 1/8" (1156)	79 5/8" (2022)	12.20 (1.13)	22.69 (2.11)	27.46 (2.55)
ISPD41611	1	10.91 (2.01)	19 3/4" (501)	21 15/16" (558)	79 5/8" (2022)	12.20 (1.13)	10.91 (1.01)	27.46 (2.55)
ISPD50611	2	28.90 (2.69)	52 1/4" (1328)	56 3/4" (1441)	79 5/8" (2022)	17.38 (1.62)	28.91 (2.69)	33.89 (3.15)
ISPD50611	1	14.02 (1.30)	25 3/8" (644)	27 9/16" (701)	79 5/8" (2022)	17.38 (1.62)	14.02 (1.30)	33.89 (3.15)
ISPD54611	2	31.12 (2.89)	56 1/4" (1430)	60 3/4" (1543)	79 5/8" (2022)	19.23 (1.79)	31.12 (2.89)	36.18 (3.36)
ISPD54611	1	15.13 (1.41)	27 3/8" (695)	29 9/16" (752)	79 5/8" (2022)	19.23 (1.79)	15.13 (1.41)	36.18 (3.36)
ISPD60611	2	35.55 (3.30)	64 1/4" (1633)	68 3/4" (1746)	79 5/8" (2022)	22.91 (2.13)	35.55 (3.30)	40.76 (3.79)
ISPD60611	1	17.34 (1.61)	31 3/8" (797)	33 9/16" (853)	79 5/8" (2022)	22.91 (2.13)	17.34 (1.61)	40.76 (3.79)
ISPD2776	1	15.28 (1.42)	25 3/8" (644)	27 9/16" (701)	86 3/4" (2203)	9.63 (0.89)	15.28 (1.42)	18.70 (1.74)
ISPD2976	1	16.48 (1.53)	27 3/8" (695)	29 9/16" (752)	86 3/4" (2203)	10.65 (0.99)	16.48 (1.53)	19.95 (1.85)
ISPD3176	1	18.89 (1.76)	31 3/8" (797)	33 9/16" (853)	86 3/4" (2203)	12.69 (1.18)	18.89 (1.76)	22.43 (2.08)
ISPD3376**	1	20.33 (1.89)	33 3/8" (847)	35 9/16" (904)	87 3/4" (2229)	12.69 (1.18)	20.33 (1.89)	23.68 (2.20)
ISPD4176	2	24.72 (2.29)	41" (1042)	45 1/8" (1156)	86 3/4" (2203)	13.51 (1.26)	24.72 (2.30)	29.83 (2.77)
ISPD4176	1	11.89 (1.11)	19 3/4" (501)	21 15/16" (558)	86 3/4" (2203)	13.51 (1.26)	11.89 (1.11)	29.83 (2.77)
ISPD5076	2	31.50 (2.93)	52 1/4" (1328)	56 3/4" (1441)	86 3/4" (2203)	19.25 (1.79)	31.50 (2.93)	36.83 (3.42)
ISPD5076	1	15.28 (1.42)	25 3/8" (644)	27 9/16" (701)	86 3/4" (2203)	19.25 (1.79)	15.28 (1.42)	36.83 (3.42)
ISPD5476	2	33.91 (3.15)	56 1/4" (1430)	60 3/4" (1543)	86 3/4" (2203)	21.29 (1.98)	33.91 (3.15)	39.31 (3.65)
ISPD5476	1	16.48 (1.53)	27 3/8" (695)	29 9/16" (752)	86 3/4" (2203)	21.29 (1.98)	16.48 (1.53)	39.31 (3.65)
ISPD6076	2	38.73 (3.60)	64 3/8" (1633)	68 3/4" (1746)	86 3/4" (2203)	25.37 (2.36)	38.73 (3.60)	44.28 (4.11)
ISPD6076	1	18.89 (1.76)	31 3/8" (797)	33 9/16" (853)	86 3/4" (2203)	25.37 (2.36)	18.90 (1.76)	44.28 (4.11)
ISPD2780	1	16.33 (1.52)	25 3/8" (644)	27 9/16" (701)	92 3/4" (2356)	10.41 (0.97)	16.33 (1.52)	19.96 (1.85)
ISPD2980	1	17.62 (1.64)	27 3/8" (695)	29 9/16" (752)	92 3/4" (2356)	11.52 (1.07)	17.62 (1.64)	21.29 (1.98)
ISPD3180	1	20.20 (1.88)	31 3/8" (797)	33 9/16" (853)	92 3/4" (2356)	13.72 (1.28)	20.20 (1.88)	23.94 (2.22)
ISPD3380**	1	21.72 (2.02)	33 3/8" (847)	35 9/16" (904)	93 3/4" (2381)	13.72 (1.28)	21.72 (2.02)	25.26 (2.35)
ISPD4180	2	26.43 (2.46)	41" (1042)	45 1/8" (1156)	92 3/4" (2356)	14.62 (1.36)	26.43 (2.46)	31.83 (2.96)
ISPD4180	1	12.71 (1.18)	19 3/4" (501)	21 15/16" (558)	92 3/4" (2356)	14.62 (1.36)	12.71 (1.18)	31.83 (2.96)
ISPD5080	2	33.68 (3.13)	52 1/4" (1328)	56 3/4" (1441)	92 3/4" (2356)	20.82 (1.94)	33.68 (3.13)	39.29 (3.65)
ISPD5080	1	16.33 (1.52)	25 3/8" (644)	27 9/16" (701)	92 3/4" (2356)	20.82 (1.94)	16.33 (1.52)	39.29 (3.65)
ISPD5480	2	36.25 (3.37)	56 1/4" (1430)	60 3/4" (1543)	92 3/4" (2356)	23.03 (2.14)	36.25 (3.37)	41.95 (3.90)
ISPD5480	1	17.62 (1.64)	27 3/8" (695)	29 9/16" (752)	92 3/4" (2356)	23.03 (2.14)	17.62 (1.64)	41.95 (3.90)
ISPD6080	2	41.40 (3.85)	64 1/4" (1633)	68 3/4" (1746)	92 3/4" (2356)	27.44 (2.55)	41.40 (3.85)	47.25 (4.39)
ISPD6080	1	20.20 (1.88)	31 3/8" (797)	33 9/16" (853)	92 3/4" (2356)	27.44 (2.55)	20.20 (1.88)	47.25 (4.39)

* Dimensions in parentheses are in millimeters or square meters.

** For two-panel active-passive or passive-active doors with only one panel open, clear opening is based on the active panel open and the passive panel closed.

*** For easier access, a special option is available that offers a 32" (813) clear opening width at 90° and a 1/2" (13) threshold. Contact your Andersen supplier for availability.

Grille Patterns

	Prairie A	Colonial	Modified Colonial	Modified Colonial with Simulated Meeting Rail	Tall Fractional	Tall Fractional with Simulated Meeting Rail	Short Fractional	Short Fractional with Simulated Meeting Rail
Hinged Inswing Patio Doors								

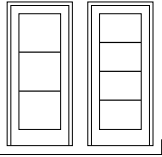

Specified Equal Light Examples

Number of lights and overall pattern varies with door size. Patterns may not be available in all configurations or sizes. Specified equal light is also available.
For more grille options, see page 15 or visit andersenwindows.com/grilles.

Hinged Inswing Patio Door Details – 4 9/16" (116) and 6 9/16" (167) Jamb Depths
Scale 1 1/2" (38) = 1'-0" (305) – 1:8

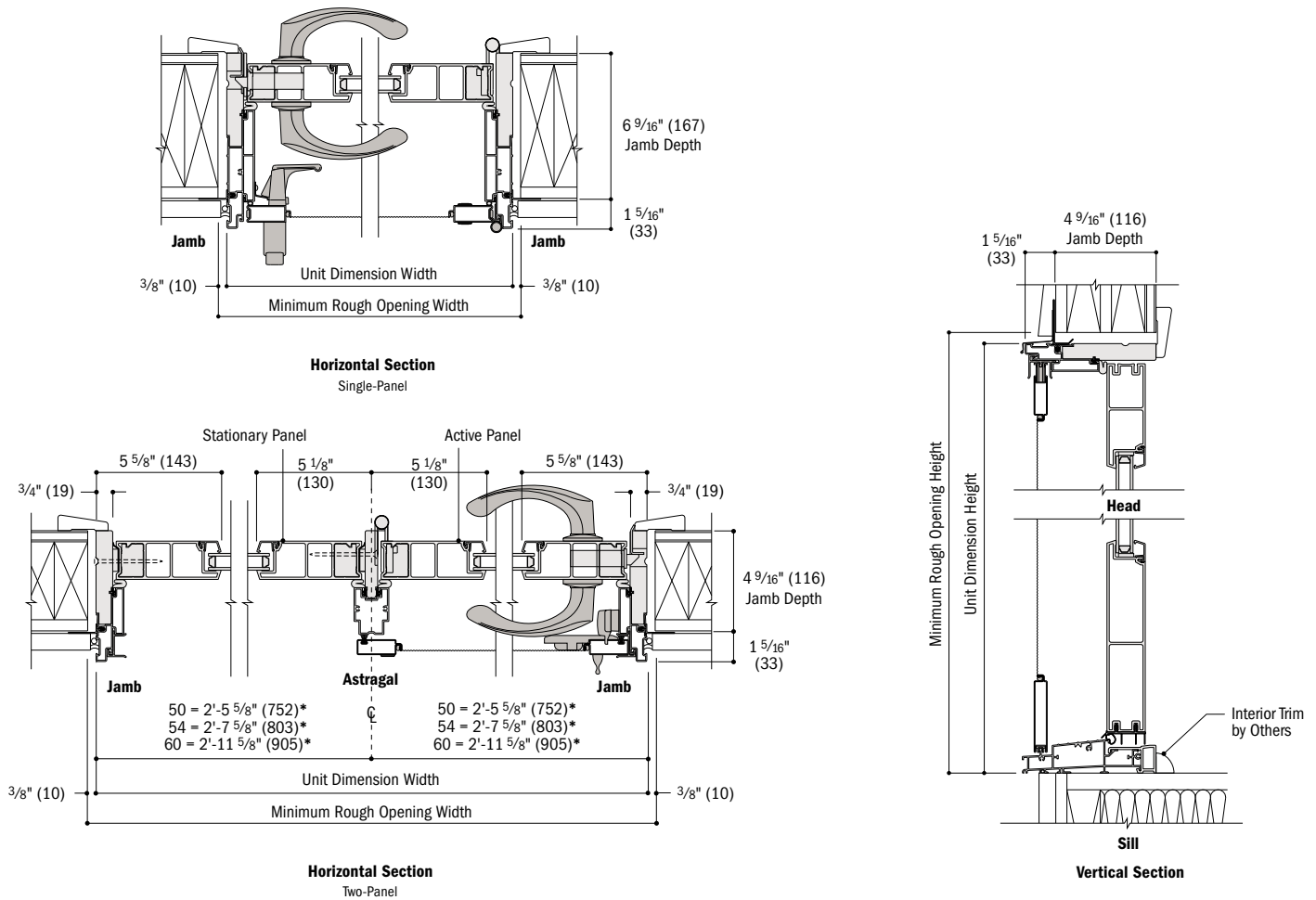

200 Series
Hinged Inswing
Patio Doors

- * 4 9/16" (116) and 6 9/16" (167) base jamb depth measurements are from back side of installation flange.
- Light-colored areas are parts included with door. Dark-colored areas are additional Andersen® parts required to complete door assembly as shown.
- Minimum rough openings may need to be increased to allow for use of building wraps, flashing, sill panning, brackets, fasteners or other items. See installation information on page 74.**
- Details are for illustration only and are not intended to represent product installation methods or materials. Refer to product installation instructions at andersenwindows.com.
- Dimensions in parentheses are in millimeters.
- *Dimensions indicate location of astragal centerline.

HINGED INSWING PATIO DOORS

Clear Opening Details

Scale 1 1/2" (38) = 1'-0" (305) – 1:8

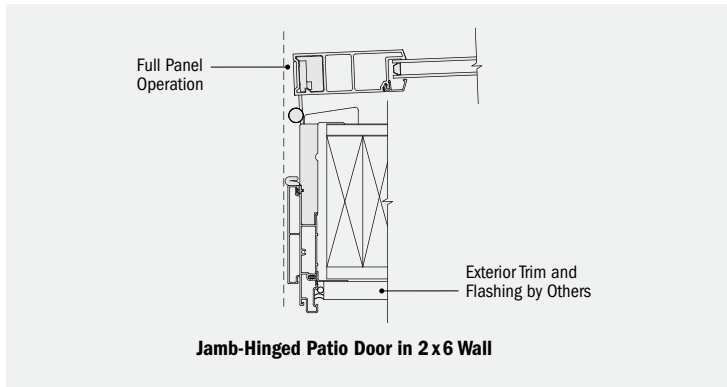
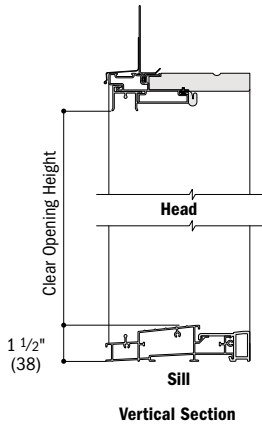
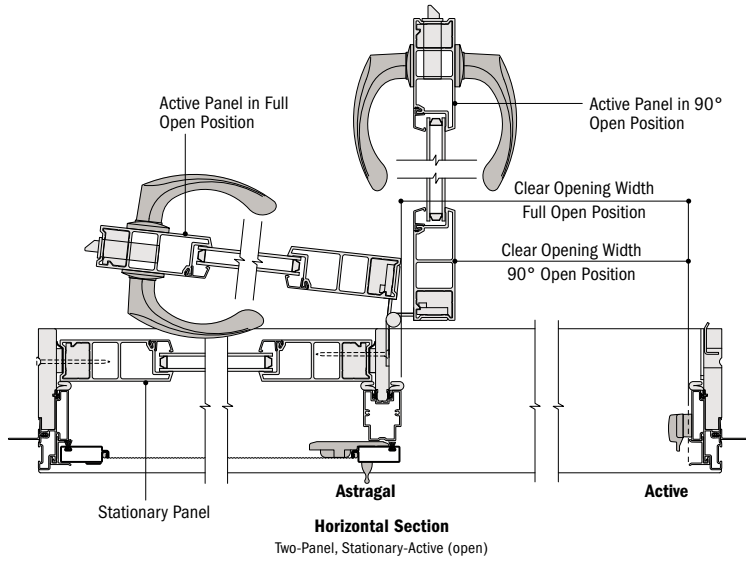

Vertical Joining Detail – Fiberglass

Scale 1 1/2" (38) = 1'-0" (305) – 1:8

Overall Door Dimension Width

Sum of individual door widths plus 3/4" (19) per join.

Overall Rough Opening Width

Overall door width plus 3/4" (19).

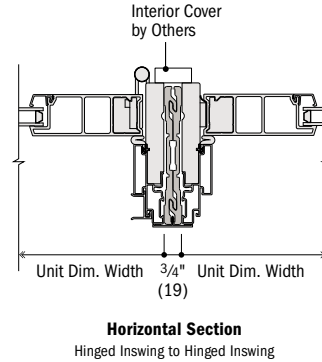

Andersen does not recommend joining of hinge jamb to hinge jamb.

For more information on joining, refer to the Combination Designs section starting on page 57.

Separate Rough Openings Detail

Scale 1 1/2" (38) = 1'-0" (305) – 1:8

To meet structural requirements or to achieve a wider joined appearance, doors may be installed into separate rough openings having vertical support by others in combination with Andersen® exterior filler and exterior vinyl trim.

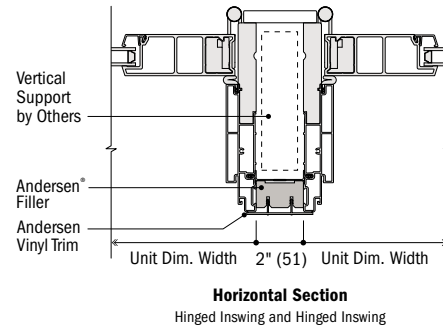

- Light-colored areas are parts included with door. Dark-colored areas are additional Andersen® parts required to complete door assembly as shown.
- **Minimum rough openings may need to be increased to allow for use of building wraps, flashing, sill panning, brackets, fasteners or other items. See installation information on page 74.**
- Details are for illustration only and are not intended to represent product installation methods or materials. Refer to product installation instructions at andersenwindows.com.
- Structural performance of any combination is only as high as the lowest structural performance of any individual product or join in the combination.
- Andersen recommends installation of doors into separate rough openings. Consult with an architect or structural engineer regarding minimum requirements for structural support members between adjacent rough openings.
- Dimensions in parentheses are in millimeters.



EXTERIOR TRIM

Flat Casings	54
Brick Mould	55
Sill Nose	55
Decorative Drip Cap	56
Cornices	56
Mull Cover	56

Exterior trim is shown with Andersen® 400 Series products.

EXTERIOR TRIM

FEATURES

EXTERIOR TRIM SYSTEM

Thick trim profiles overlap the window frame to create clean lines without visible sealant joints. Profiles are shown on page 53.

- A** For exceptional long-lasting* performance, exterior trim is made from Fibrex® material or high-density urethane with low-maintenance exterior finishes.
- B** Sill nose profile, made from Fibrex material, is placed at the sill for a traditional look.
- C** Rigid vinyl exterior trim attachment strips (field applied) allow the trim to be securely fastened to the home.
- D** Trim surrounds are assembled with corner keys and stainless steel fasteners for stability and strength.



Made of Fibrex material that is an environmentally smart composite, containing 40% pre-consumer recycled wood fiber by weight.



Flat casing and sill nose in white shown with a 400 Series Terratone window.

Drip Cap

Full-length, color-matched aluminum drip cap is included with kits and surrounds.

End Caps

End caps provide a clean appearance when joining two trim members.

Corner Keys

Corner keys provide tight alignment of corner joints.

Fasteners

Screws are made of high-quality stainless steel and provide corner joints with a secure, tight fit.

Optional Head Trim

Head trim can be added above our flat casing and includes an integrated installation flange. The decorative drip cap is made from our Fibrex material. Both the 2" (51) cornice and 3 5/8" (92) cornice are made from highly durable urethane material. See page 53.

Easy Installation

- Installs independently of a water management system
- No nail holes to fill
- No visible fasteners
- No painting

INSTALLATION OPTIONS

Preassembled Trim Surrounds

Factory-assembled surrounds install quickly and eliminate measuring, cutting, mitering and filling nail holes.

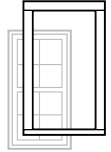

Precut Kits

Knock-down kits include precut and predrilled trim with all the necessary components for on-site assembly for windows.

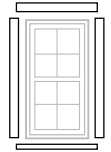

Individual Trim Components

13' (3962) factory-finished trim lineals, end caps, corner keys, fasteners, metal drip caps and field attachment strips allow for field fabrication and assembly.



Visit andersenwindows.com for exterior trim installation instructions

EXTERIOR TRIM COLORS



COMBINATIONS

Mix and match trim to create a variety of combinations. For more information or to design a window with exterior trim, visit andersenwindows.com/exteriortrim.

Flat Casing

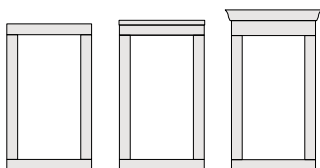

Flat casing on four sides with optional decorative drip cap or cornice.

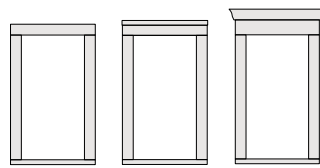

Flat casing on three sides with optional decorative drip cap or cornice.

Brick Mould

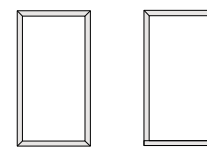

Brick mould on four sides.

Brick mould on three sides with sill nose.

*See the 200 Series limited warranty for exterior trim applied to 200 Series products. Visit andersenwindows.com/warranty for details. Printing limitations prevent exact duplication of colors. See your Andersen supplier for actual color samples.

Dimensions in parentheses are in millimeters.

PROFILES



2" (51) Brick Mould in dove gray with Terratone window



3 1/2" (89) Flat Casing in dark bronze with white window



4 1/2" (114) Flat Casing in canvas with black window

HEAD OPTIONS



Decorative Drip Cap with 3 1/2" (89) flat casing in cocoa bean with Sandtone window



2" (51) Cornice with 3 1/2" (89) flat casing in cocoa bean with Sandtone window



3 5/8" (92) Cornice with 3 1/2" (89) flat casing in cocoa bean with Sandtone window

SILL OPTION



2" (114) Brick Mould with sill nose in dove gray with Terratone window



3 1/2" (114) Flat Casing with sill nose in dark bronze with white window



4 1/2" (114) Flat Casing with sill nose in canvas with black window

ACCESSORIES

INSTALLATION

Specialty Trim



Made of highly durable factory-finished urethane material for selected shapes. Contact your Andersen supplier for availability.

Fibrex® Trim Board



Available in the same 11 colors as our exterior trim, this solid cellular Fibrex trim board can be cut or ripped to size, and fastened using nails or screws. 3 1/2" (89) wide by 3/4" (19) thick in 10' (3048) lengths.

Coil Stock



Andersen aluminum coil stock allows you to form your own profiles in the field and can be ordered to match any of our 11 exterior trim colors. Made from .018"-thick aluminum, coil stock is available in 24" (610) x 50' (15240) rolls. Color-matched 1 1/4" (32)-long stainless steel trim nails are also available and can be ordered in 1 lb./454 kg boxes.

EXTERIOR TRIM

Window and Patio Door Attachment

Field-Applied Attachment Strip

A field-applied attachment strip fastens to the framing through the window or patio door installation flange and flashing tape with screws. Exterior trim connects securely to the field-applied attachment strip. Follow window and patio door installation guides for flashing instructions.

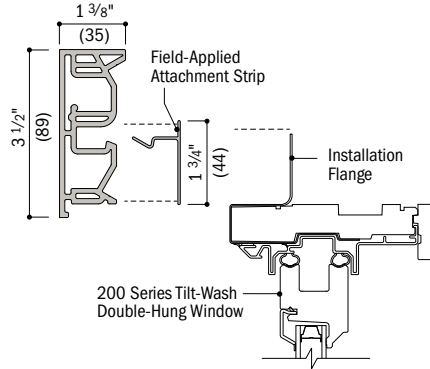

3 1/2" and 4 1/2" Flat Casings

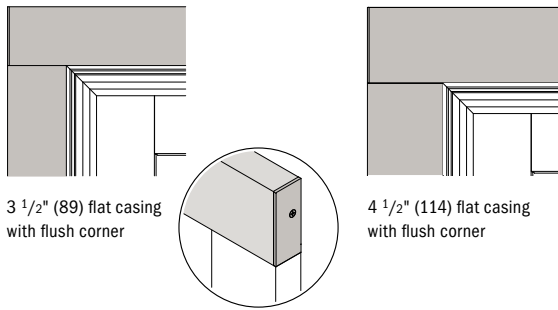

3 1/2" (89) flat casing with flush corner

4 1/2" (114) flat casing with flush corner

Formula for dimension of window/door plus exterior trim:

Add 4 1/4" (108) per side for 4 1/2" (114) flat casing

Add 3 1/4" (83) per side for 3 1/2" (89) flat casing

Trim Details

Scale 3" (76) = 1'-0" (305) – 1:4

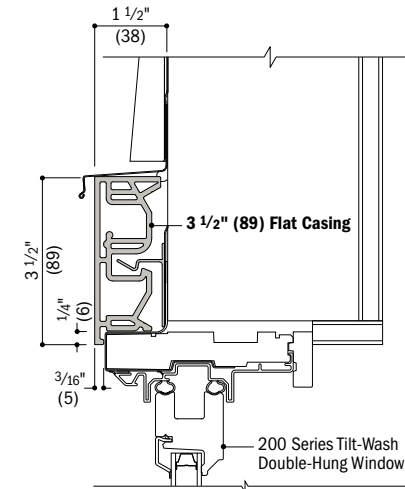

Vertical Section

200 Series Tilt-Wash Double-Hung Window with 3 1/2" (89) Flat Casing

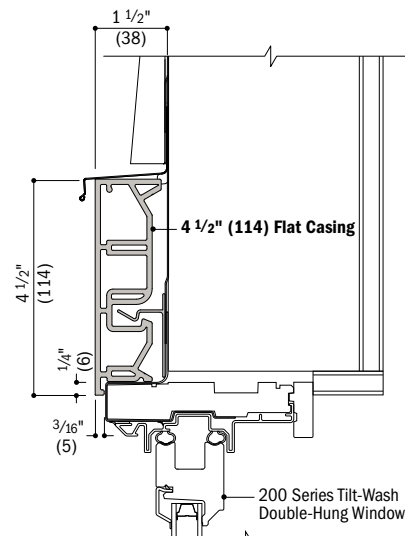

Vertical Section

200 Series Tilt-Wash Double-Hung Window with 4 1/2" (114) Flat Casing

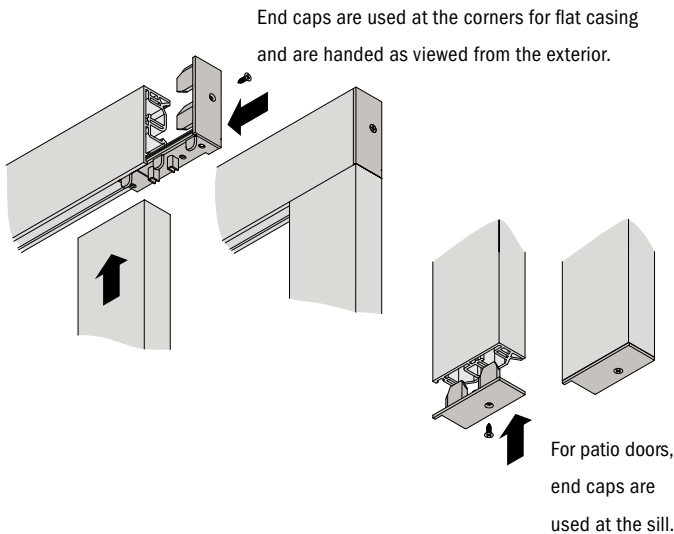

* Dimensions in parentheses are in millimeters.

* Typical trim combinations shown. Additional combinations may also be used. Some restrictions apply. For more information, contact your Andersen supplier.

* Details are for illustration only and are not intended to represent product installation methods or materials. Refer to product installation guides at andersenwindows.com.

Brick Mould

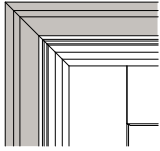

Brick mould with mitered corners

Formula for dimension of window/door plus exterior trim:

Add 1 3/4" (44) per side for brick mould

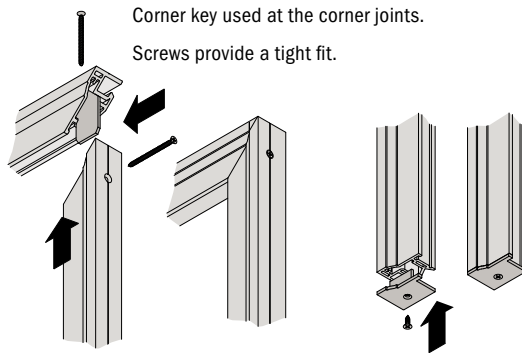

For patio doors, end caps are used at the sill.

Trim Detail

Scale 3" (76) = 1'-0" (305) – 1:4

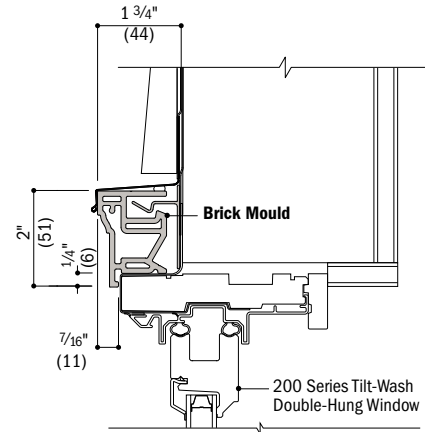

Vertical Section

200 Series Tilt-Wash Double-Hung Window with Brick Mould

Sill Nose

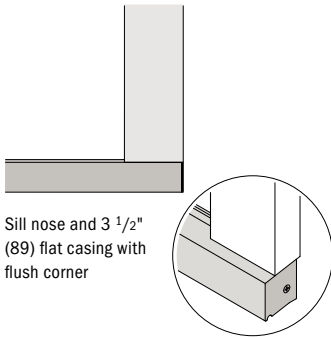

Sill nose and 3 1/2" (89) flat casing with flush corner

Formula for dimension of window plus exterior trim:

Add 1 15/16" (49) for sill nose

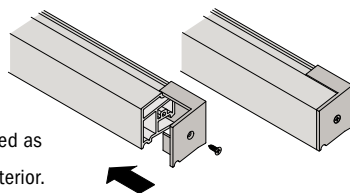

End caps are handed as viewed from the exterior.

Trim Detail

Scale 3" (76) = 1'-0" (305) – 1:4

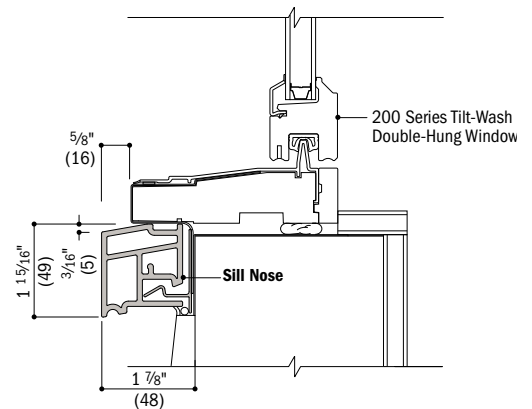

Vertical Section

200 Series Tilt-Wash Double-Hung Window with Sill Nose

Exterior Trim

• Dimensions in parentheses are in millimeters.
• Typical trim combinations shown. Additional combinations may also be used. Some restrictions apply. For more information, contact your Andersen supplier.
• Details are for illustration only and are not intended to represent product installation methods or materials. Refer to product installation guides at andersenwindows.com.

EXTERIOR TRIM

Decorative Drip Cap

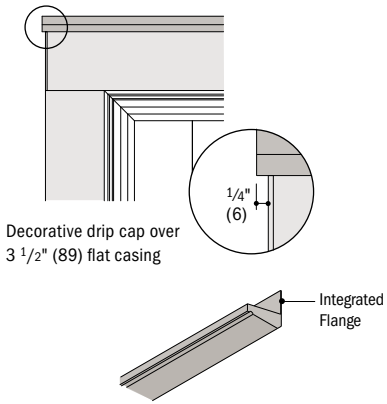

Cornices

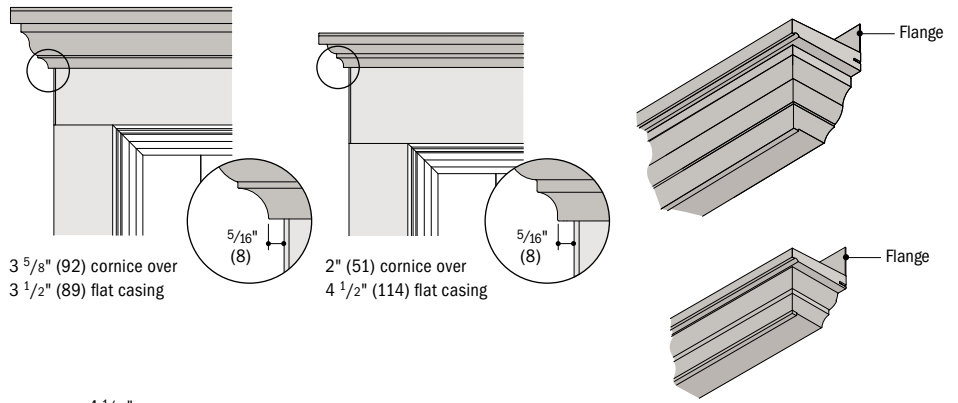

Details

Scale 3" (76) = 1'-0" (305) - 1:4

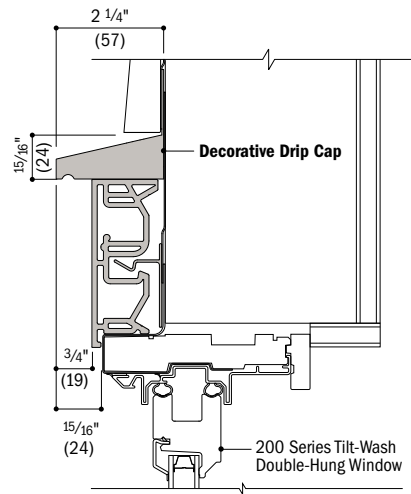

Vertical Section
200 Series Tilt-Wash Double-Hung Window with 3 1/2" (89) Flat Casing and Decorative Drip Cap

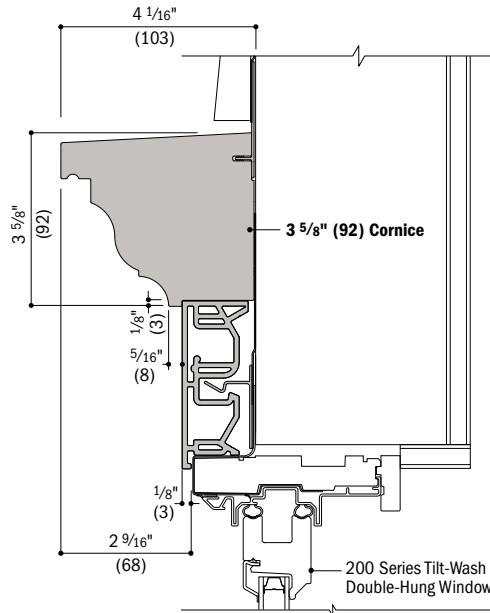

Vertical Section
200 Series Tilt-Wash Double-Hung Window with 3 1/2" (89) Flat Casing and 3 5/8" (92) Cornice

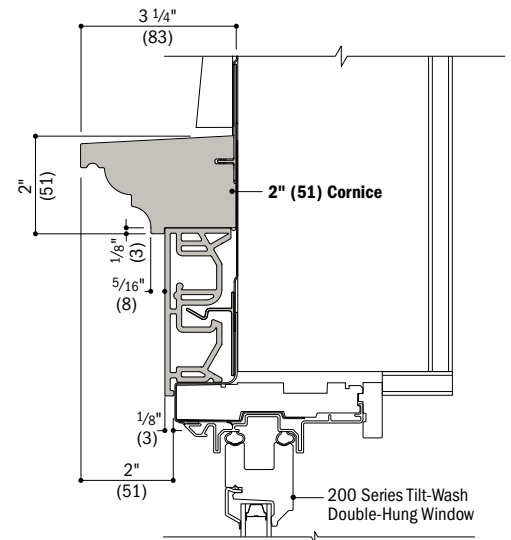

Vertical Section
200 Series Tilt-Wash Double-Hung Window with 3 1/2" (89) Flat Casing and 2" (51) Cornice

Mull Cover

A 3 3/4" (95) mull cover is available for installations where windows or patio doors have been installed into separate rough openings to obtain a joined appearance.

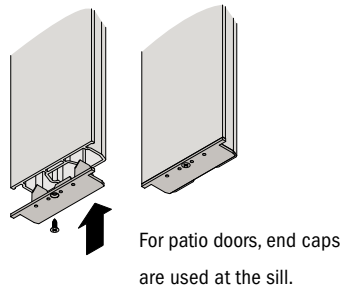

Separate Rough Openings Detail

Scale 3" (76) = 1'-0" (305) - 1:4

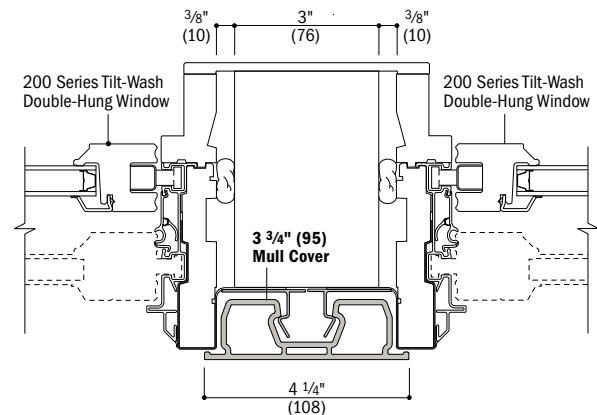

Horizontal Section
200 Series Tilt-Wash Double-Hung Windows and 3 3/4" (95) Mull Cover

* Dimensions in parentheses are in millimeters.
* Typical trim combinations shown. Additional combinations may also be used. Some restrictions apply. For more information, contact your Andersen supplier.
* Details are for illustration only and are not intended to represent product installation methods or materials. Refer to product installation guides at andersenwindows.com.
* Consult with an architect or structural engineer regarding minimum requirements for structural support members between adjacent rough openings.

Andersen® window and patio doors make it easy to create a wide variety of combination designs

Combination Types

Ribbons

Ribbons are horizontal window combinations (vertical joins) where opposite ends (head and sill) of individual windows are fastened to the building structure.

Stacks

Stacks are vertical window combinations (horizontal joins) where opposite sides (both side jambs) of individual windows are fastened to the building structure.

Two basic configurations are used in combination designs:
One-way configurations or two-way configurations.

One-Way

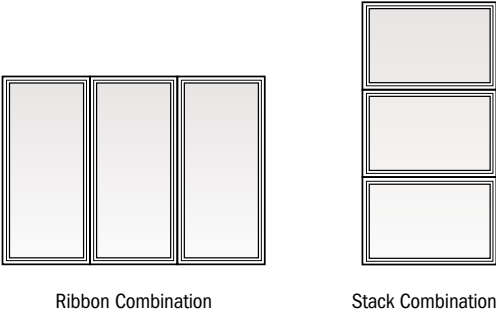

Two-Way

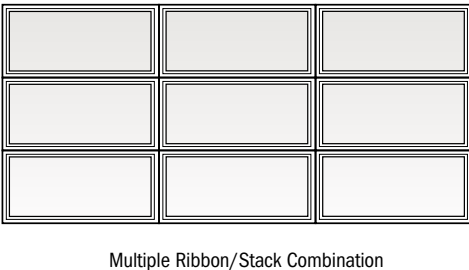

Two-way combinations exist when multiple vertical stacks and horizontal ribbons are joined together. Unlike one-way combinations, the adjacent sides (head and sill, or both side jambs) of individual units are not necessarily fastened directly to the building structure. Two-way combinations are joined with both vertical and horizontal joining material, and may require reinforced joining materials and brackets depending on the local building code requirement for design wind load (measured in pounds per square foot, psf).

Determining Design Wind Load Performance

Proper combination design in conformance with local wind load requirements is vital to the success of your project. To make sure a combination is safe and that it complies with local building codes, the combination design wind load performance capacity must be determined.

Correctly determining this performance capacity involves the following three steps:

STEP 1

Determine Building Code Requirement

Make sure you have the proper local codes and have identified specified compliance values. This calculated value (psf) will be used to determine if the combination will be acceptable (STEP 3).



STEP 2

Determine Product Performance

Compare product Design Pressure Rating data to the local building code (psf) requirement. This will show whether the individual units in a combination design are acceptable.



STEP 3

Determine Combination Performance

This step helps determine whether a given product, size, configuration and joining material type will meet the local building code design wind load requirement. To determine what joining material type to use (fiberglass, steel or wood), compare the local building code design wind load requirement to the design wind load table value for a particular joining material on the following pages.

Combination Designs, Product Performance & Installation

COMBINATION DESIGNS

Andersen® Joining Materials

For a successful installation, one engineered to provide the required design pressure, it is important Andersen joining materials and installation accessories be specified by a project architect or contractor. For one- and two-way combinations, Andersen offers joining materials to meet specified performance requirements. Combinations are joined using either fiberglass, steel or wood material depending on the product types. Each creates a joining system that enhances the look of Andersen products without sacrificing performance.

The addition of joining materials will affect the overall rough opening dimension; see page 74. **For all joining methods, read and follow product joining installation instructions in their entirety. Visit andersenwindows.com for instructions.**

A variety of exterior trim strips for finishing the space between joined products are available in colors to match Andersen windows and patio doors. Interior casing is available in several wood types, pre-finished options, sizes and style options. Components used with each joining system will vary depending on products being joined. Contact your Andersen supplier for more information.

Materials vary depending on type of units being joined and wind load requirements. Non-reinforced joining material is used to create alignment and positive joining between windows. Joining materials are not connected to the rough opening structure. Non-reinforced joins can also be achieved using accessory items such as V-notch gusset plates. Contact your Andersen supplier for specific performance and product recommendations.

Reinforced joining material is used to create product alignment, positive joining and load transfer between Andersen windows and patio doors and the rough opening. They provide added strength capable of withstanding a greater range of wind load pressures. The structural performance of any combination is only as high as the lowest structural performance rating of any individual unit or joining material in the combination.

Fiberglass Joining Material

Fiberglass joining material is available for 200 Series patio door combinations. The fiberglass joining material utilizes either $\frac{3}{4}$ " (19) x $5\frac{3}{4}$ " (146) fiberglass interlocking joining plates for $4\frac{9}{16}$ " (116) jamb depths or $\frac{3}{4}$ " (19) x $7\frac{3}{4}$ " (197) fiberglass interlocking joining plates for higher performance for one-way and two-way joining, and is required for hinged inswing patio doors with $6\frac{9}{16}$ " (167) jambs. Joining kits are available for joining and installing patio door, sidelight and/or transom combinations at the job site. Extension jamb kits are also available. In some situations, joining material may prohibit the application of perimeter extension jambs. For more information, contact your Andersen supplier.

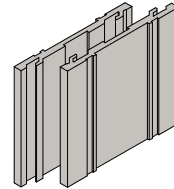
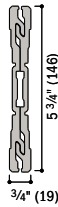
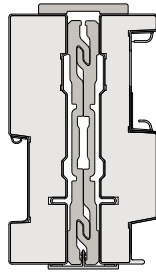

**$\frac{3}{4}$ " (19) x $5\frac{3}{4}$ " (146)
Fiberglass Joining Material**
For $4\frac{9}{16}$ " (116) jamb depths.

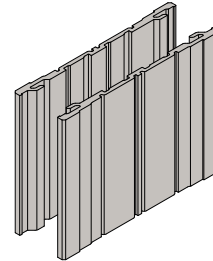
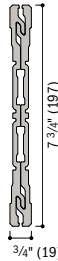

**$\frac{3}{4}$ " (19) x $7\frac{3}{4}$ " (197)
Fiberglass Joining Material**
For higher performance for 1-way and 2-way joining. Required for hinged inswing patio doors with $6\frac{9}{16}$ " (167) base jamb depths.

Steel Joining Material

Steel joining material is available in 8'-0 $\frac{1}{4}$ " (2445), 9'-6" (2896) and 12'-6" (3810) lengths. Treated for corrosion resistance, a 4" (102) depth of material provides strength and rigidity. Intended for use with select Andersen 200 Series and 400 Series patio door to window joins. Adjacent windows attach to the steel joining material with screws.

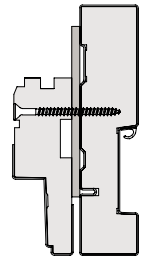

* Structural performance of any combination is only as high as the lowest structural performance of any individual unit or joining material in the combination.
• Dimensions in parentheses are in millimeters.

1-Way Wood Joining with Non-Reinforced Gusset Plates

200 Series Tilt-Wash Double-Hung, Picture and Transom Windows

Average Adjacent Window Dimension	$(A+B) \div 2 = 6'-0"$ (1829)	50	50	50	41	31	24
	$(A+B) \div 2 = 5'-6"$ (1676)	50	50	50	41	31	24
	$(A+B) \div 2 = 5'-0"$ (1524)	50	50	50	41	31	25
	$(A+B) \div 2 = 4'-6"$ (1372)	50	50	50	42	32	26
	$(A+B) \div 2 = 4'-0"$ (1219)	50	50	50	44	34	28
	$(A+B) \div 2 = 3'-6"$ (1067)	50	50	50	47	37	31
	$(A+B) \div 2 = 3'-0"$ (914)	50	50	50	50	42	35
	$(A+B) \div 2 = 2'-6"$ (762)	50	50	50	50	49	40
	$(A+B) \div 2 = 2'-0"$ (610)	50	50	50	50	50	50
	$(A+B) \div 2 = 1'-6"$ (457)	50	50	50	50	50	50
C = (length of join)	3'-6" (1067)	4'-0" (1219)	4'-6" (1372)	5'-0" (1524)	5'-6" (1676)	6'-0" (1829)	

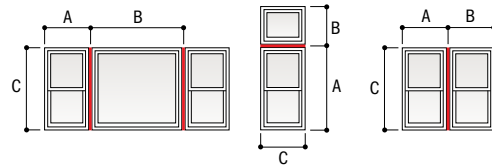

Only one-way combinations similar to those shown above are allowed.

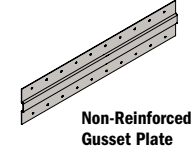
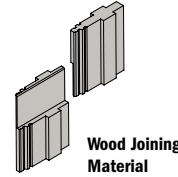

2-Way Wood Joining with V-Notch Gusset Plates

200 Series Tilt-Wash Double-Hung, Picture and Transom Windows

Average Adjacent Window Dimension	$(A+B) \div 2 = 6'-0"$ (1829)	40	30	24						
	$(A+B) \div 2 = 5'-6"$ (1676)	43	33	26	21					
	$(A+B) \div 2 = 5'-0"$ (1524)	48	36	29	23					
	$(A+B) \div 2 = 4'-6"$ (1372)	50	41	32	26	21				
	$(A+B) \div 2 = 4'-0"$ (1219)	50	46	36	29	24	20			
	$(A+B) \div 2 = 3'-6"$ (1067)	50	50	41	33	27	23			
	$(A+B) \div 2 = 3'-0"$ (914)	50	50	48	39	32	27	23	20	
	$(A+B) \div 2 = 2'-6"$ (762)	50	50	50	47	39	32	27	24	21
	$(A+B) \div 2 = 2'-0"$ (610)	50	50	50	50	48	41	34	30	26
	$(A+B) \div 2 = 1'-6"$ (457)	50	50	50	50	50	50	46	40	35
C = (length of join)	3'-6" (1067)	4'-0" (1219)	4'-6" (1372)	5'-0" (1524)	5'-6" (1676)	6'-0" (1829)	6'-6" (1981)	7'-0" (2134)	7'-6" (2286)	

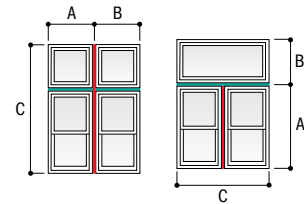

Red lines represent priority join (dimension C in table).

Only two-way combinations similar to those shown above are allowed.

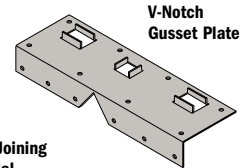
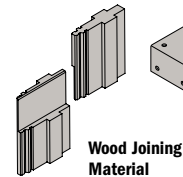

Design Criteria for 2-Way Joining with V-Notch Gusset Plates:

- Ribbons or stacks of 5 windows or less with a maximum width/height of 12' (3658).
- No inverted T-joints or palladian configurations are allowed.
- Two-way combinations are limited to a maximum 7'-6" (2286) height and have vertical joining priority.

1-Way Jamb-to-Jamb Joining

200 Series Narroline® and Perma-Shield® Gliding Patio Doors

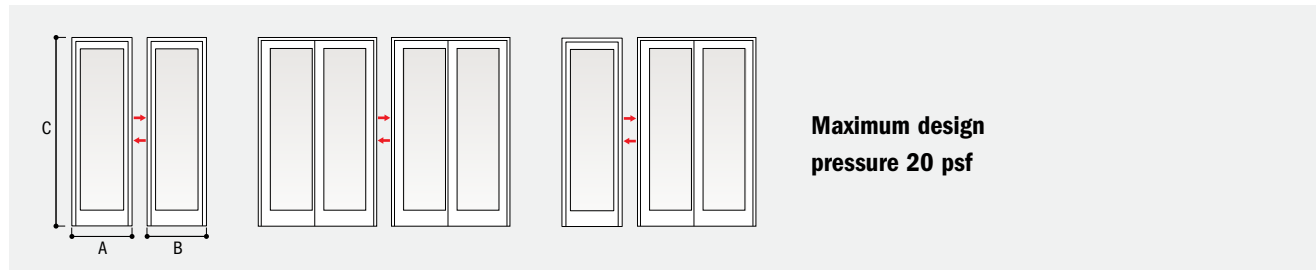

- Numerical values in charts represent structural pressure only.
- Structural performance of any combination is only as high as the lowest structural performance of any individual unit or joining material in the combination.
- Andersen® products must be installed and anchored properly according to joining and installation guides to meet rated structural performance. Refer to product joining and installation instructions at andersenwindows.com.
- Additional wind load tables are available at andersenwindows.com.
- Dimensions in parentheses are in millimeters.

COMBINATION DESIGNS

1-Way Fiberglass Joining

200 Series Narroline® and Perma-Shield® Gliding Patio Doors, Hinged Inswing Patio Doors; 400 Series Frenchwood® Patio Door Sidelights and Transoms

4 9/16" (116) Minimum Wall Depth	Average Adjacent Door/Sidelight/Transom Dimension	(A + B) ÷ 2 = 12'-0" (3658)	45	45	45	45	45	45	45	45	45	45	45	45	
		(A + B) ÷ 2 = 11'-6" (3505)	45	45	45	45	45	45	45	45	45	45	45	45	45
		(A + B) ÷ 2 = 11'-0" (3353)	45	45	45	45	45	45	45	45	45	45	45	45	45
		(A + B) ÷ 2 = 10'-6" (3200)	45	45	45	45	45	45	45	45	45	45	45	45	45
		(A + B) ÷ 2 = 10'-0" (3048)	45	45	45	45	45	45	45	45	45	45	45	45	45
		(A + B) ÷ 2 = 9'-6" (2896)	45	45	45	45	45	45	45	45	45	45	45	45	45
		(A + B) ÷ 2 = 9'-0" (2743)	45	45	45	45	45	45	45	45	45	45	45	45	45
		(A + B) ÷ 2 = 8'-6" (2591)	45	45	45	45	45	45	45	45	45	45	45	45	45
		(A + B) ÷ 2 = 8'-0" (2438)	45	45	45	45	45	45	45	45	45	45	45	45	45
		(A + B) ÷ 2 = 7'-6" (2286)	45	45	45	45	45	45	45	45	45	45	45	45	45
		(A + B) ÷ 2 = 7'-0" (2134)	45	45	45	45	45	45	45	45	45	45	45	45	45
		(A + B) ÷ 2 = 6'-6" (1981)	45	45	45	45	45	45	45	45	45	45	45	45	45
		(A + B) ÷ 2 = 6'-0" (1829)	45	45	45	45	45	45	45	45	45	45	45	45	45
		(A + B) ÷ 2 = 5'-6" (1676)	45	45	45	45	45	45	45	45	45	45	45	45	45
		(A + B) ÷ 2 = 5'-0" (1524)	45	45	45	45	45	45	45	45	45	45	45	45	45
		(A + B) ÷ 2 = 4'-6" (1372)	45	45	45	45	45	45	45	45	45	45	45	45	45
		(A + B) ÷ 2 = 4'-0" (1219)	45	45	45	45	45	45	45	45	45	45	45	45	45
		(A + B) ÷ 2 = 3'-6" (1067)	45	45	45	45	45	45	45	45	45	45	45	45	45
		(A + B) ÷ 2 = 3'-0" (914)	45	45	45	45	45	45	45	45	45	45	45	45	45
		(A + B) ÷ 2 = 2'-6" (762)	45	45	45	45	45	45	45	45	45	45	45	45	45
(A + B) ÷ 2 = 2'-0" (610)	45	45	45	45	45	45	45	45	45	45	45	45	45		
(A + B) ÷ 2 = 1'-6" (457)	45	45	45	45	45	45	45	45	45	45	45	45	45		
C = (length of join)	2'-0" (610)	2'-6" (762)	3'-0" (914)	3'-6" (1067)	4'-0" (1219)	4'-6" (1372)	5'-0" (1524)	5'-6" (1676)	6'-0" (1829)	6'-6" (1981)	7'-0" (2134)	7'-6" (2286)	8'-0" (2438)		

continued on next page

1-Way Fiberglass Joining

200 Series Narroline® and Perma-Shield® Gliding Patio Doors, Hinged Inswing Patio Doors; 400 Series Frenchwood® Patio Door Sidelights and Transoms

6 9/16" (167) Minimum Wall Depth	Average Adjacent Door/Sidelight/Transom Dimension	(A + B) ÷ 2 = 12'-0" (3658)	45	45	45	45	45	45	45	45	45	45	45	45	
		(A + B) ÷ 2 = 11'-6" (3505)	45	45	45	45	45	45	45	45	45	45	45	45	45
		(A + B) ÷ 2 = 11'-0" (3048)	45	45	45	45	45	45	45	45	45	45	45	45	45
		(A + B) ÷ 2 = 10'-6" (3200)	45	45	45	45	45	45	45	45	45	45	45	45	45
		(A + B) ÷ 2 = 10'-0" (3048)	45	45	45	45	45	45	45	45	45	45	45	45	45
		(A + B) ÷ 2 = 9'-6" (2896)	45	45	45	45	45	45	45	45	45	45	45	45	45
		(A + B) ÷ 2 = 9'-0" (2743)	45	45	45	45	45	45	45	45	45	45	45	45	45
		(A + B) ÷ 2 = 8'-6" (2591)	45	45	45	45	45	45	45	45	45	45	45	45	45
		(A + B) ÷ 2 = 8'-0" (2438)	45	45	45	45	45	45	45	45	45	45	45	45	45
		(A + B) ÷ 2 = 7'-6" (2286)	45	45	45	45	45	45	45	45	45	45	45	45	45
		(A + B) ÷ 2 = 7'-0" (2134)	45	45	45	45	45	45	45	45	45	45	45	45	45
		(A + B) ÷ 2 = 6'-6" (1981)	45	45	45	45	45	45	45	45	45	45	45	45	45
		(A + B) ÷ 2 = 6'-0" (1829)	45	45	45	45	45	45	45	45	45	45	45	45	45
		(A + B) ÷ 2 = 5'-6" (1676)	45	45	45	45	45	45	45	45	45	45	45	45	45
		(A + B) ÷ 2 = 5'-0" (1524)	45	45	45	45	45	45	45	45	45	45	45	45	45
		(A + B) ÷ 2 = 4'-6" (1372)	45	45	45	45	45	45	45	45	45	45	45	45	45
		(A + B) ÷ 2 = 4'-0" (1219)	45	45	45	45	45	45	45	45	45	45	45	45	45
		(A + B) ÷ 2 = 3'-6" (1067)	45	45	45	45	45	45	45	45	45	45	45	45	45
		(A + B) ÷ 2 = 3'-0" (914)	45	45	45	45	45	45	45	45	45	45	45	45	45
		(A + B) ÷ 2 = 2'-6" (762)	45	45	45	45	45	45	45	45	45	45	45	45	45
(A + B) ÷ 2 = 2'-0" (610)	45	45	45	45	45	45	45	45	45	45	45	45	45		
(A + B) ÷ 2 = 1'-6" (457)	45	45	45	45	45	45	45	45	45	45	45	45	45		
C = (length of join)	2'-0" (610)	2'-6" (762)	3'-0" (914)	3'-6" (1067)	4'-0" (1219)	4'-6" (1372)	5'-0" (1524)	5'-6" (1676)	6'-0" (1829)	6'-6" (1981)	7'-0" (2134)	7'-6" (2286)	8'-0" (2438)		

* Numerical values in charts represent structural pressure only.

* Structural performance of any combination is only as high as the lowest structural performance of any individual unit or joining material in the combination.

* Andersen® products must be installed and anchored properly according to joining and installation guides to meet rated structural performance. Refer to product joining and installation instructions at andersenwindows.com.

* Dimensions in parentheses are in millimeters.

* Hinged inswing patio doors with a 6 9/16" (167) or greater exterior extension jamb depth require 7 3/4" (197) fiberglass joining material.

continued on next page

1-Way Fiberglass Joining continued from previous page

45	37	30	24	20	16		
45	37	30	24	20	16		
45	37	30	24	20	16		
45	37	30	24	20	17		
45	37	30	24	20	17		
45	37	30	24	20	17		
45	37	30	25	20	17	15	
45	38	30	25	21	18	15	
45	38	31	26	21	18	16	
45	39	32	26	22	19	16	
45	40	33	27	23	20	17	15
45	41	34	29	24	21	18	15
45	43	36	30	26	22	19	16
45	45	38	32	27	24	20	18
45	45	41	35	30	26	22	19
45	45	45	38	32	28	24	21
45	45	45	42	36	31	27	24
45	45	45	45	41	35	31	27
45	45	45	45	45	41	35	31
45	45	45	45	45	45	42	37
45	45	45	45	45	45	42	45
45	45	45	45	45	45	45	45
8'-6" (2591)	9'-0" (2743)	9'-6" (2896)	10'-0" (3048)	10'-6" (3200)	11'-0" (3353)	11'-6" (3505)	12'-0" (3658)

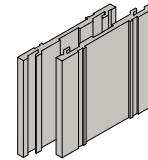
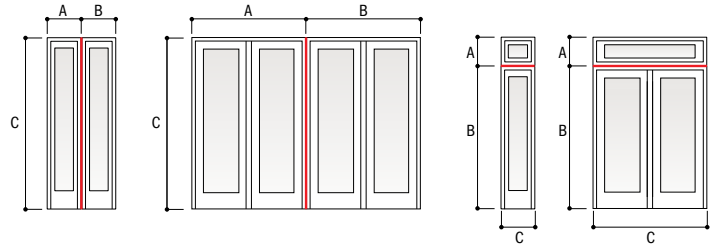

**¾" (19) x 5 ¾" (146)
Fiberglass Joining Material**
For 4 7/16" (116) base jamb depths.

**When joining hinged inswing patio doors,
do not join hinge jamb to hinge jamb.**

**Always use a structural header to separate transom
windows from four-panel gliding patio doors.**

1-Way Fiberglass Joining continued from previous page

45	45	45	45	45	39	32	27	23	20	17	15
45	45	45	45	45	39	32	27	23	20	17	15
45	45	45	45	45	39	32	27	23	20	18	15
45	45	45	45	45	39	33	28	24	21	18	16
45	45	45	45	45	39	33	28	24	21	18	17
45	45	45	45	45	40	34	29	25	21	19	17
45	45	45	45	45	40	34	29	25	22	19	17
45	45	45	45	45	41	35	30	26	23	20	18
45	45	45	45	45	43	36	31	27	24	21	19
45	45	45	45	45	44	38	33	29	25	22	20
45	45	45	45	45	45	40	34	30	26	23	21
45	45	45	45	45	45	42	36	32	28	25	22
45	45	45	45	45	45	44	39	34	30	26	23
45	45	45	45	45	45	45	42	36	32	28	25
45	45	45	45	45	45	45	45	40	35	31	28
45	45	45	45	45	45	45	45	43	38	34	30
45	45	45	45	45	45	45	45	45	43	38	34
45	45	45	45	45	45	45	45	45	45	43	39
45	45	45	45	45	45	45	45	45	45	45	45
45	45	45	45	45	45	45	45	45	45	45	45
45	45	45	45	45	45	45	45	45	45	45	45
45	45	45	45	45	45	45	45	45	45	45	45
8'-6" (2591)	9'-0" (2743)	9'-6" (2896)	10'-0" (3048)	10'-6" (3200)	11'-0" (3353)	11'-6" (3505)	12'-0" (3658)	12'-6" (3810)	13'-0" (3962)	13'-6" (4114)	14'-0" (4267)

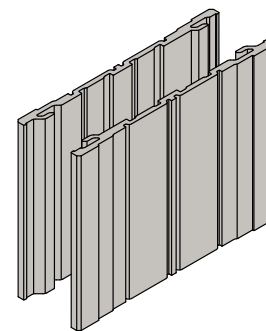

**¾" (19) x 7 ¾" (197)
Fiberglass Joining Material**
For higher performance for 1-way and 2-way joining.
Required for hinged inswing patio doors with 6 7/16" (167)
or greater exterior extension jamb depths.

**When joining hinged inswing patio doors,
do not join hinge jamb to hinge jamb.**

**Always use a structural header to separate transom
windows from four-panel gliding patio doors.**

- * Numerical values in charts represent structural pressure only.
- * Structural performance of any combination is only as high as the lowest structural performance of any individual unit or joining material in the combination.
- * Andersen® products must be installed and anchored properly according to joining and installation guides to meet rated structural performance. Refer to product joining and installation instructions at andersenwindows.com.
- * Dimensions in parentheses are in millimeters.
- * Hinged inswing patio doors with a 6 7/16" (167) or greater exterior extension jamb depth require 7 3/4" (197) fiberglass joining material.

Combination Designs,
Product Performance
& Installation

COMBINATION DESIGNS

2-Way Fiberglass Joining

200 Series Narroline® and Perma-Shield® Gliding Patio Doors, Hinged Inswing Patio Doors; 400 Series Frenchwood® Patio Door Sidelights and Transoms

4 9/16" (116) Minimum Wall Depth	Average Adjacent Door/Sidelight/Transom Dimension	(A + B) ÷ 2 = 12'-0" (3658)	45	45	45	45	45	45	41	38	34	32	29	27	25	
		(A + B) ÷ 2 = 11'-6" (3505)	45	45	45	45	45	45	45	43	39	36	33	31	29	27
		(A + B) ÷ 2 = 11'-0" (3353)	45	45	45	45	45	45	45	45	41	38	35	32	30	28
		(A + B) ÷ 2 = 10'-6" (3200)	45	45	45	45	45	45	45	45	43	39	36	34	31	29
		(A + B) ÷ 2 = 10'-0" (3048)	45	45	45	45	45	45	45	45	45	41	38	35	33	31
		(A + B) ÷ 2 = 9'-6" (2896)	45	45	45	45	45	45	45	45	45	44	40	37	35	32
		(A + B) ÷ 2 = 9'-0" (2743)	45	45	45	45	45	45	45	45	45	45	42	39	37	34
		(A + B) ÷ 2 = 8'-6" (2591)	45	45	45	45	45	45	45	45	45	45	45	42	39	36
		(A + B) ÷ 2 = 8'-0" (2438)	45	45	45	45	45	45	45	45	45	45	45	44	41	38
		(A + B) ÷ 2 = 7'-6" (2286)	45	45	45	45	45	45	45	45	45	45	45	45	44	41
		(A + B) ÷ 2 = 7'-0" (2134)	45	45	45	45	45	45	45	45	45	45	45	45	45	44
		(A + B) ÷ 2 = 6'-6" (1981)	45	45	45	45	45	45	45	45	45	45	45	45	45	45
		(A + B) ÷ 2 = 6'-0" (1829)	45	45	45	45	45	45	45	45	45	45	45	45	45	45
		(A + B) ÷ 2 = 5'-6" (1676)	45	45	45	45	45	45	45	45	45	45	45	45	45	45
		(A + B) ÷ 2 = 5'-0" (1524)	45	45	45	45	45	45	45	45	45	45	45	45	45	45
		(A + B) ÷ 2 = 4'-6" (1372)	45	45	45	45	45	45	45	45	45	45	45	45	45	45
		(A + B) ÷ 2 = 4'-0" (1219)	45	45	45	45	45	45	45	45	45	45	45	45	45	45
		(A + B) ÷ 2 = 3'-6" (1067)	45	45	45	45	45	45	45	45	45	45	45	45	45	45
		(A + B) ÷ 2 = 3'-0" (914)	45	45	45	45	45	45	45	45	45	45	45	45	45	45
		(A + B) ÷ 2 = 2'-6" (762)	45	45	45	45	45	45	45	45	45	45	45	45	45	45
(A + B) ÷ 2 = 2'-0" (610)	45	45	45	45	45	45	45	45	45	45	45	45	45	45		
(A + B) ÷ 2 = 1'-6" (457)	45	45	45	45	45	45	45	45	45	45	45	45	45	45		
C = (length of join)	2'-0" (610)	2'-6" (762)	3'-0" (914)	3'-6" (1067)	4'-0" (1219)	4'-6" (1372)	5'-0" (1524)	5'-6" (1676)	6'-0" (1829)	6'-6" (1981)	7'-0" (2134)	7'-6" (2286)	8'-0" (2438)			

continued on next page

2-Way Fiberglass Joining

200 Series Narroline® and Perma-Shield® Gliding Patio Doors, Hinged Inswing Patio Doors; 400 Series Frenchwood® Patio Door Sidelights and Transoms

6 9/16" (167) Minimum Wall Depth	Average Adjacent Door/Sidelight/Transom Dimension	(A + B) ÷ 2 = 12'-0" (3658)	45	45	45	45	45	45	45	41	38	35	33	31		
		(A + B) ÷ 2 = 11'-6" (3505)	45	45	45	45	45	45	45	45	43	40	37	34	32	
		(A + B) ÷ 2 = 11'-0" (3048)	45	45	45	45	45	45	45	45	45	41	38	36	34	
		(A + B) ÷ 2 = 10'-6" (3200)	45	45	45	45	45	45	45	45	45	43	40	38	35	
		(A + B) ÷ 2 = 10'-0" (3048)	45	45	45	45	45	45	45	45	45	45	42	40	37	
		(A + B) ÷ 2 = 9'-6" (2896)	45	45	45	45	45	45	45	45	45	45	45	45	42	39
		(A + B) ÷ 2 = 9'-0" (2743)	45	45	45	45	45	45	45	45	45	45	45	45	44	41
		(A + B) ÷ 2 = 8'-6" (2591)	45	45	45	45	45	45	45	45	45	45	45	45	45	44
		(A + B) ÷ 2 = 8'-0" (2438)	45	45	45	45	45	45	45	45	45	45	45	45	45	45
		(A + B) ÷ 2 = 7'-6" (2286)	45	45	45	45	45	45	45	45	45	45	45	45	45	45
		(A + B) ÷ 2 = 7'-0" (2134)	45	45	45	45	45	45	45	45	45	45	45	45	45	45
		(A + B) ÷ 2 = 6'-6" (1981)	45	45	45	45	45	45	45	45	45	45	45	45	45	45
		(A + B) ÷ 2 = 6'-0" (1829)	45	45	45	45	45	45	45	45	45	45	45	45	45	45
		(A + B) ÷ 2 = 5'-6" (1676)	45	45	45	45	45	45	45	45	45	45	45	45	45	45
		(A + B) ÷ 2 = 5'-0" (1524)	45	45	45	45	45	45	45	45	45	45	45	45	45	45
		(A + B) ÷ 2 = 4'-6" (1372)	45	45	45	45	45	45	45	45	45	45	45	45	45	45
		(A + B) ÷ 2 = 4'-0" (1219)	45	45	45	45	45	45	45	45	45	45	45	45	45	45
		(A + B) ÷ 2 = 3'-6" (1067)	45	45	45	45	45	45	45	45	45	45	45	45	45	45
		(A + B) ÷ 2 = 3'-0" (914)	45	45	45	45	45	45	45	45	45	45	45	45	45	45
		(A + B) ÷ 2 = 2'-6" (762)	45	45	45	45	45	45	45	45	45	45	45	45	45	45
(A + B) ÷ 2 = 2'-0" (610)	45	45	45	45	45	45	45	45	45	45	45	45	45	45		
(A + B) ÷ 2 = 1'-6" (457)	45	45	45	45	45	45	45	45	45	45	45	45	45	45		
C = (length of join)	2'-0" (610)	2'-6" (762)	3'-0" (914)	3'-6" (1067)	4'-0" (1219)	4'-6" (1372)	5'-0" (1524)	5'-6" (1676)	6'-0" (1829)	6'-6" (1981)	7'-0" (2134)	7'-6" (2286)	8'-0" (2438)			

* Numerical values in charts represent structural pressure only.

* Structural performance of any combination is only as high as the lowest structural performance of any individual unit or joining material in the combination.

* Andersen® products must be installed and anchored properly according to joining and installation guides to meet rated structural performance. Refer to product joining and installation instructions at andersenwindows.com.

* Dimensions in parentheses are in millimeters.

* Hinged inswing patio doors with a 6 9/16" (167) or greater exterior extension jamb depth require 7 3/4" (197) fiberglass joining material.

continued on next page

2-Way Fiberglass Joining continued from previous page

21	18	15											
22	18	16											
23	19	16											
24	20	17	15										
25	21	18	16										
27	22	19	16										
28	24	20	17	15									
30	25	21	18	16									
32	27	23	19	17									
34	29	24	21	18	15								
36	31	26	22	19	17								
39	33	28	24	21	18	16							
43	36	30	26	22	19	17	15						
45	39	33	28	24	21	19	16						
45	43	37	31	27	23	20	18						
45	45	41	35	30	26	23	20						
45	45	45	39	34	29	26	23						
45	45	45	45	39	34	29	26						
45	45	45	45	45	39	34	29	26					
45	45	45	45	45	45	39	34	30					
45	45	45	45	45	45	45	41	36					
45	45	45	45	45	45	45	45	45					
45	45	45	45	45	45	45	45	45					
8'-6" (2591)	9'-0" (2743)	9'-6" (2896)	10'-0" (3048)	10'-6" (3200)	11'-0" (3353)	11'-6" (3505)	12'-0" (3658)						

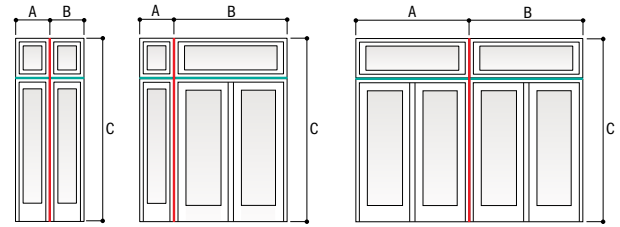

Red lines represent reinforced joints.
Blue lines represent non-reinforced joints.

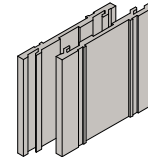

3/4" (19) x 5 3/4" (146)
Fiberglass Joining Material
For 4 9/16" (116) base jamb depths.

When joining hinged inswing patio doors, do not join hinge jamb to hinge jamb.
Always use a structural header to separate transom windows from four-panel gliding patio doors.

2-Way Fiberglass Joining continued from previous page

29	27	26	25	22	20	19	17	16						
30	28	27	26	23	21	19	18	16	15					
32	30	28	27	25	22	20	19	17	16	15				
33	31	30	28	26	23	21	20	18	17	15				
35	33	31	30	27	25	22	21	19	17	16	15			
37	35	33	31	28	26	24	22	20	18	17	16			
39	37	35	33	30	27	25	23	21	19	18	17			
41	39	37	35	32	29	26	24	22	21	19	18			
44	41	39	37	34	31	28	26	24	22	20	19			
45	44	42	40	36	33	30	28	25	23	22	20			
45	45	45	42	39	35	32	30	27	25	23	22			
45	45	45	45	42	38	35	32	29	27	25	23			
45	45	45	45	45	41	38	35	32	29	27	25			
45	45	45	45	45	45	41	38	35	32	30	28			
45	45	45	45	45	45	45	42	38	35	33	30			
45	45	45	45	45	45	45	45	43	39	36	34			
45	45	45	45	45	45	45	45	45	44	41	38			
45	45	45	45	45	45	45	45	45	45	45	44			
45	45	45	45	45	45	45	45	45	45	45	45			
45	45	45	45	45	45	45	45	45	45	45	45			
45	45	45	45	45	45	45	45	45	45	45	45			
45	45	45	45	45	45	45	45	45	45	45	45			
45	45	45	45	45	45	45	45	45	45	45	45			
8'-6" (2591)	9'-0" (2743)	9'-6" (2896)	10'-0" (3048)	10'-6" (3200)	11'-0" (3353)	11'-6" (3505)	12'-0" (3658)	12'-6" (3810)	13'-0" (3962)	13'-6" (4114)	14'-0" (4267)			

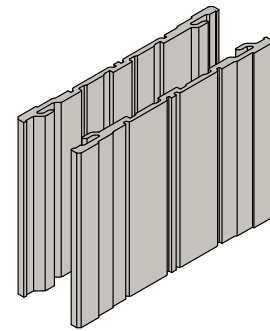

3/4" (19) x 7 3/4" (197)
Fiberglass Joining Material
For higher performance for 1-way and 2-way joining. Required for hinged inswing patio doors with 6 9/16" (167) or greater exterior extension jamb depths.

When joining hinged inswing patio doors, do not join hinge jamb to hinge jamb.
Always use a structural header to separate transom windows from four-panel gliding patio doors.

- Numerical values in charts represent structural pressure only.
- Structural performance of any combination is only as high as the lowest structural performance of any individual unit or joining material in the combination.
- Andersen® products must be installed and anchored properly according to joining and installation guides to meet rated structural performance. Refer to product joining and installation instructions at andersenwindows.com.
- Dimensions in parentheses are in millimeters.
- Hinged inswing patio doors with a 6 9/16" (167) or greater exterior extension jamb depth require 7 3/4" (197) fiberglass joining material.

**Combination Designs,
Product Performance
& Installation**

Altitude Limits for Products With Dual-Pane Glass

The chart below gives the altitude limit in feet for 200 Series products in this guide. If the installation of a given product is at an altitude greater than that shown in this chart, a capillary breather tube must be ordered. Be aware that the use of a capillary breather tube eliminates argon gas blend fill and will result in a slightly lower thermal performance (approximately 0.02 increase in window U-Factor). For NFRC certified total unit performance on units with capillary breather tubes for higher altitude applications, see your Andersen supplier.

The use of dual-pane insulating glass without capillary breather tubes at altitudes higher than its rating will result in severe glass distortion, increased glass breakage potential and a risk of seal failure. Smaller windows are most affected by altitude changes. An increase in altitude results in a decrease in atmospheric pressure. A sealed insulating glass unit attempts to combat this change by increasing its volume to reduce its pressure. One way to increase its volume is by glass deflection. A smaller window is stiffer and does not deflect as much as a larger window; therefore, it cannot relieve the pressure as readily. Thus, the load applied to the glass is greater, resulting in a greater risk for breakage. Another way the window tries to increase its volume is by increasing the edge area; i.e., the seal area. The increased pressure applied to the edge seal load for a smaller window is therefore greater, increasing the chance for seal failure.

Andersen® Product	3,000	4,000	5,000	6,000	7,000	8,000	9,000	10,000
200 Series Tilt-Wash Double-Hung Windows			DH1830 DH2030 DH1836 DH2430 DH1840 DH2830 DH1846 DH3030 DH1849 DH3430 DH1850 DH1856 DH1860	DH2036 DH2440 DH2040 DH2836 DH2046 DH2840 DH2049 DH3036 DH2050 DH3040 DH2056 DH3436 DH2060 DH3440 DH2436	DH2446 DH2449 DH2450 DH2456 DH2460 DH2846 DH3046 DH3446	DH2849 DH3049 DH3449	DH2850 DH2856 DH2860 DH3050 DH3450	DH3056 DH3060 DH3456 DH3460
200 Series Tilt-Wash Picture Windows		FX4610 FX5010				FX3030 FX5630 FX3040 FX6030 FX3046 FX3049 FX3050 FX3056 FX3060 FX4030 FX4630 FX4930 FX5030		FX4040 FX4660 FX5056 FX4046 FX4940 FX5060 FX4049 FX4946 FX5640 FX4050 FX4949 FX5646 FX4056 FX4950 FX5649 FX4060 FX4956 FX5650 FX4640 FX4960 FX6040 FX4646 FX5040 FX6046 FX4649 FX5046 FX6049 FX4650 FX5049 FX6050 FX4656 FX5050
200 Series Tilt-Wash Transom Windows		FX1810 FX2810 FX1816 FX2816 FX1820 FX3010 FX2010 FX3016 FX2016 FX3410 FX2410 FX3416 FX2416	FX2020 FX2420 FX2820 FX3020 FX3420					
200 Series Tilt-Wash Half Circle Window	CT18 CT20	CT24 CT28 CT30	CT34					
200 Series Gliding Windows			GW3020 GW3030 GW4016	GW3036 GW4036 GW3040 GW4040 GW4020 GW4046 GW4030 GW4050			GW5030 GW5050 GW5036 GW5040 GW4046 GW5046	GW6030 GW6050 GW6036 GW6040 GW6046
200 Series Narroline® Gliding Patio Doors							NLGD5068 NLGD50611 NLGD5080	NLGD6068 NLGD8068 NLGD60611 NLGD80611 NLGD6080 NLGD8080
200 Series Perma-Shield® Gliding Patio Doors							PS5068	PS51168 PS81611 PS61611 PS8180 PS6180
200 Series Hinged Inswing Patio Doors		ISPD4168 ISPD4180 ISPD41611 ISPD4176			ISPD5068 ISPD5080 ISPD50611 ISPD5076	ISPD5468 ISPD5480 ISPD54611 ISPD5476		ISPD6068 ISPD6080 ISPD60611 ISPD6076

- Deflection of glass will occur on units with larger glass areas. If interior/exterior grilles are used on double-hung windows, gliding windows or gliding patio doors at higher altitudes without capillary breather tubes, some interference may occur, affecting operation.
- Altitude limits for patio doors shown in two-panel configurations. These limits also qualify for same-size panels used in single- or multi-panel configurations.
- Contact your Andersen supplier for altitude limits for custom-sized gliding patio doors.

Altitude Limits for Products With Triple-Pane Glass

The chart below gives the altitude limit in feet for 200 Series gliding patio doors in this guide. If the installation of a given product is at an altitude greater than that shown in this chart, a capillary breather tube must be ordered. Be aware that the use of a capillary breather tube eliminates argon gas blend fill and will result in a slightly lower thermal performance (approximately 0.02 increase in window U-Factor). For NFRC certified total unit performance on units with capillary breather tubes for higher altitude applications, see your Andersen supplier.

The use of triple-pane insulating glass without capillary breather tubes at altitudes higher than its rating will result in severe glass distortion, increased glass breakage potential and a risk of seal failure. Smaller windows are most affected by altitude changes. An increase in altitude results in a decrease in atmospheric pressure. A sealed insulating glass unit attempts to combat this change by increasing its volume to reduce its pressure. One way to increase its volume is by glass deflection. A smaller window is stiffer and does not deflect as much as a larger window; therefore, it cannot relieve the pressure as readily. Thus, the load applied to the glass is greater, resulting in a greater risk for breakage. Another way the window tries to increase its volume is by increasing the edge area; i.e., the seal area. The increased pressure applied to the edge seal load for a smaller window is therefore greater, increasing the chance for seal failure.

Andersen® Product	3,000	4,000	5,000	6,000	7,000	8,000	9,000	10,000
200 Series Narroline® Gliding Patio Doors								NLGD5068 NLGD6068 NLGD8068 NLGD50611 NLGD60611 NLGD80611 NLGD5080 NLGD6080 NLGD8080
200 Series Perma-Shield® Gliding Patio Doors								PS5068 PS6180 PS51168 PS81611 PS61611 PS8180

- Deflection of glass will occur on units with larger glass areas. If interior/exterior grilles are used on gliding patio doors at higher altitudes without capillary breather tubes, some interference may occur, affecting operation.
- Altitude limits for patio doors shown in two-panel configurations. These limits also qualify for same-size panels used in single- or multi-panel configurations.
- Contact your Andersen supplier for altitude limits for custom-sized gliding patio doors.

**Combination Designs,
Product Performance
& Installation**

Performance Grade and Air Infiltration Ratings

For current performance information, please visit andersenwindows.com.

Andersen® 200 Series Product	AAMA/WDMA/CSA 101/I.S.2/A440 Performance Grade (PG)	+/- Corresponding Design Pressure (DP)	Air Infiltration CFM/FT ²
Tilt-Wash Windows			
Double-Hung	Class R-PG30 Size Tested 39.5" x 71.5"	30/30	< 0.2
Picture	Class LC-PG50 Size Tested 71.5" x 59.5"	50/50	< 0.2
Half Circle	Class LC-PG50 Size Tested 71.5" x 59.5"	50/50	< 0.2
Gliding Windows			
	Class R-PG20 Size Tested 71.5" x 59.5"	20/20	< 0.2
Narrowline® Gliding Patio Doors			
Single Stationary	Class LC-PG40 Size Tested 50.0" x 95.5"	40/40	< 0.2
Two-Panel (6068)	Class LC-PG35 Size Tested 71.3" x 79.5"	35/35	< 0.2
Two-Panel (60611)	Class LC-PG40 Size Tested 71.3" x 82.4"	40/40	< 0.2
Two-Panel (8080)	Class LC-PG25 Size Tested 95.5" x 95.5"	25/25	< 0.2
Two-Panel (6080)	Class LC-PG30 Size Tested 71.3" x 95.5"	30/30	< 0.2
Four-Panel	Class LC-PG25 Size Tested 189.0" x 95.5"	25/25	< 0.2
Perma-Shield® Gliding Patio Doors			
Single Stationary	Class LC-PG45 Size Tested 50.4" x 95.5"	45/45	< 0.2
Two-Panel	Class LC-PG25 Size Tested 96.0" x 95.5"	25/25	< 0.2
Two-Panel, PG Upgrade (60611, 6068)	Class LC-PG40 Size Tested 96.0" x 82.4"	40/40	< 0.2
Hinged Inswing Patio Doors			
Single Active	Class LC-PG30 Size Tested 38.1" x 95.5"	30/30	< 0.2
Two-Panel	Class LC-PG30 Size Tested 71.3" x 95.5"	30/30	< 0.2

- Performance Grade (PG) ratings may vary from tested performance rating for larger or smaller units of a particular type.
- This data is accurate as of July 2024. Due to ongoing product changes, updated test results or new industry standards, this data may change over time.
- Where designated, Andersen products are certified and labeled to the requirements of the Hallmark Certification Program. Actual performance may vary based on variations in manufacturing, shipping, installation, environmental conditions and conditions of use.
- Contact your Andersen supplier for more information.

Sound Transmission Ratings

For current performance information, please visit andersenwindows.com.

Andersen® 200 Series Product	Glass Construction	Sound Transmission Class (STC)	Indoor/Outdoor Transmission Class (OITC)
Tilt-Wash Windows			
Double-Hung	Dual-Pane	27	22
Picture	Dual-Pane	29	24
Gliding Windows			
	Dual-Pane	27	22
Narrowline® Gliding Patio Doors			
Single Stationary	Dual-Pane	30	24
	Triple-Pane	†	†
Two-Panel	Dual-Pane	30	24
	Triple-Pane	†	†
Four-Panel	Dual-Pane	†	†
	Triple-Pane	†	†
Perma-Shield® Gliding Patio Doors			
Single Stationary	Dual-Pane	30	24
	Triple-Pane	†	†
Single Stationary With Blinds-Between-the-Glass	Dual-Pane	31	24
	Triple-Pane	†	†
Two-Panel	Dual-Pane	29	23
	Triple-Pane	29	24
Two-Panel With Blinds-Between-the-Glass	Dual-Pane	30	24
	Triple-Pane	†	†
Hinged Inswing Patio Doors			
Single Active	Dual-Pane	32	27
Two-Panel	Dual-Pane	30	24

- Sound Transmission Class (STC) and Indoor/Outdoor Transmission Class (OITC) ratings are for individual units based on independent tests and represent entire unit.
- This data is accurate as of July 2024. Due to ongoing product changes, updated test results or new industry standards, this data may change over time.
- Contact your Andersen supplier for more information.
- †Data not available.

Combination Designs,
Product Performance
& Installation

PERFORMANCE

Center of Glass Performance for Products With Dual-Pane Glass

For current performance information, please visit andersenwindows.com.

Andersen® 200 Series Product	VT ¹	SC ²	SHGC ³	RHG ⁴	Fading		%RH @ center ⁷	IGST ⁸
					Tuv ⁵	Tdw ⁶		
Low-E								
Tilt-Wash Double-Hung and Gliding Windows	73%	0.48	0.42	99	17%	34%	61%	56°F
Picture, Transom and Half Circle Windows	72%	0.47	0.41	98	16%	33%	59%	55°F
Perma-Shield® Gliding Patio Doors	72%	0.47	0.41	98	16%	33%	59%	55°F
Narroline® Gliding and Hinged Inswing Patio Doors	72%	0.48	0.41	98	16%	33%	61%	56°F
Low-E With HeatLock® Technology								
Tilt-Wash Double-Hung and Gliding Windows	71%	0.47	0.41	97	17%	33%	44%	47°F
Picture, Transom and Half Circle Windows	70%	0.47	0.40	95	16%	32%	44%	47°F
Perma-Shield Gliding Patio Doors	70%	0.47	0.40	95	16%	32%	44%	47°F
Narroline Gliding and Hinged Inswing Patio Doors	70%	0.47	0.41	96	16%	32%	44%	47°F
Low-E SmartSun™								
Tilt-Wash Double-Hung and Gliding Windows	66%	0.31	0.27	66	5%	22%	61%	56°F
Picture, Transom and Half Circle Windows	65%	0.31	0.27	65	5%	21%	61%	56°F
Perma-Shield Gliding Patio Doors	65%	0.31	0.27	65	5%	21%	61%	56°F
Narroline Gliding and Hinged Inswing Patio Doors	65%	0.31	0.27	65	5%	21%	61%	56°F
Low-E SmartSun With HeatLock Technology								
Tilt-Wash Double-Hung and Gliding Windows	64%	0.31	0.27	64	5%	21%	46%	48°F
Picture, Transom and Half Circle Windows	63%	0.31	0.27	63	5%	20%	44%	47°F
Perma-Shield Gliding Patio Doors	63%	0.31	0.27	63	5%	20%	44%	47°F
Narroline Gliding and Hinged Inswing Patio Doors	63%	0.31	0.27	64	5%	20%	46%	48°F
Low-E Sun								
Tilt-Wash Double-Hung and Gliding Windows	39%	0.21	0.18	44	2%	13%	61%	56°F
Picture, Transom and Half Circle Windows	39%	0.20	0.18	43	2%	13%	61%	56°F
Perma-Shield Gliding Patio Doors	39%	0.20	0.18	43	2%	13%	61%	56°F
Narroline Gliding and Hinged Inswing Patio Doors	39%	0.20	0.18	44	2%	13%	61%	56°F
Low-E PassiveSun								
Tilt-Wash Double-Hung and Gliding Windows	80%	0.80	0.70	164	31%	43%	59%	55°F
Picture, Transom and Half Circle Windows	79%	0.79	0.69	161	29%	42%	59%	55°F
Perma-Shield Gliding Patio Doors	79%	0.79	0.69	161	29%	42%	59%	55°F
Narroline Gliding and Hinged Inswing Patio Doors	79%	0.79	0.69	161	29%	42%	59%	55°F
Low-E PassiveSun With HeatLock Technology								
Tilt-Wash Double-Hung and Gliding Windows	78%	0.73	0.63	148	29%	42%	42%	46°F
Picture, Transom and Half Circle Windows	77%	0.72	0.62	146	27%	40%	42%	46°F
Perma-Shield Gliding Patio Doors	77%	0.72	0.62	146	27%	40%	42%	46°F
Narroline Gliding and Hinged Inswing Patio Doors	77%	0.72	0.62	146	27%	40%	42%	46°F
Clear Dual-Pane								
Tilt-Wash Double-Hung and Gliding Windows	83%	0.91	0.79	190	63%	64%	38%	43°F
Picture, Transom and Half Circle Windows	82%	0.89	0.78	186	58%	61%	39%	44°F
Perma-Shield Gliding Patio Doors	82%	0.89	0.78	186	58%	61%	39%	44°F
Narroline Gliding and Hinged Inswing Patio Doors	82%	0.89	0.78	186	58%	61%	39%	44°F

* Based on NFRC testing/simulation conditions using Windows v7.8.57.0 and NFRC validated spectral data. 0°F outside temperature, 70°F inside temperature and a 12 mph wind.
 1) Visible Transmittance (VT) measures how much light comes through the glass. The higher the value, from 0 to 1, the more daylight the glass lets in. Visible Transmittance is measured over the 380-760 nanometer portion of the solar spectrum. 2) Shading Coefficient (SC) defines the amount of heat gain through the glass compared to a single lite of clear 1/8" (3) glass. The lower the value, the less heat is transmitted through the product. 3) Solar Heat Gain Coefficient (SHGC) defines the fraction of solar radiation admitted through the glass directly transmitted, as well as absorbed and subsequently released inward. 4) Relative Heat Gain (RHG) is the amount of heat gain through a glazing incorporating U-Factor and Solar Heat Gain Coefficient. 5) Transmission Ultra-Violet Energy (Tuv). The transmission of short-wave energy in the 300-380 nanometer portion of the solar spectrum. The energy can cause fabric fading. 6) Transmission Damage Function (Tdw). The transmission of UV and visible light energy in the 300-600 nanometer portion of the solar spectrum. The value includes both the UV and visible light energy that can cause fabric fading. This rating has also been referred to as the Krochmann Damage Function. This rating better predicts fading potential than UV transmission alone. The lower the Damage Function rating, the less transmission of short-wave energy through the glass that can potentially cause fabric fading. Fabric type is also a key component of fading potential. 7) Percent relative humidity before condensation occurs at the center of glass, taken using center of glass temperature. 8) Inside glass surface temperatures are taken at the center of glass.
 * This data is accurate as of July 2024. Due to ongoing product changes, updated test results or new industry standards, this data may change over time. Contact your Andersen supplier for current performance information or upgrade options.
 * Contact your Andersen supplier for center of glass performance data on windows with patterned glass, tempered glass and products ordered with capillary breather tubes.

Center of Glass Performance Data for Products With Triple-Pane Glass

For current performance information, please visit andersenwindows.com.

Triple-Pane Glass	Andersen® 200 Series Product	VT ¹	SC ²	SHGC ³	RHG ⁴	Fading		%RH @ center ⁷	IGST ⁸
						Tuv ⁵	Tdw ⁶		
Low-E									
	Narroline® and Perma-Shield® Gliding Patio Doors	66%	0.44	0.38	92	14%	30%	63%	57°F
Low-E Enhanced									
	Narroline and Perma-Shield Gliding Patio Doors	63%	0.43	0.37	88	8%	24%	71%	60°F
Low-E Enhanced With HeatLock® Technology									
	Narroline and Perma-Shield Gliding Patio Doors	62%	0.41	0.36	84	8%	23%	55%	53°F
Low-E SmartSun™									
	Narroline and Perma-Shield Gliding Patio Doors	59%	0.29	0.25	62	4%	19%	66%	58°F
Low-E SmartSun Enhanced									
	Narroline and Perma-Shield Gliding Patio Doors	57%	0.28	0.25	59	2%	16%	71%	60°F
Low-E SmartSun Enhanced With HeatLock Technology									
	Narroline and Perma-Shield Gliding Patio Doors	56%	0.27	0.24	57	2%	16%	55%	53°F

* Based on NFRC testing/simulation conditions using Windows v7.8.57.0 and NFRC validated spectral data. 0°F outside temperature, 70°F inside temperature and a 12 mph wind.
 1) Visible Transmittance (VT) measures how much light comes through the glass. The higher the value, from 0 to 1, the more daylight the glass lets in. Visible Transmittance is measured over the 380-760 nanometer portion of the solar spectrum. 2) Shading Coefficient (SC) defines the amount of heat gain through the glass compared to a single lite of clear 1/8" (3) glass. 3) Solar Heat Gain Coefficient (SHGC) defines the fraction of solar radiation admitted through the glass directly transmitted, as well as absorbed and subsequently released inward. The lower the value, the less heat is transmitted through the product. 4) Relative Heat Gain (RHG) is the amount of heat gain through a glazing incorporating U-Factor and Solar Heat Gain Coefficient. 5) Transmission Ultra-Violet Energy (Tuv). The transmission of short-wave energy in the 300-380 nanometer portion of the solar spectrum. The energy can cause fabric fading. 6) Transmission Damage Function (Tdw). The transmission of UV and visible light energy in the 300-600 nanometer portion of the solar spectrum. The value includes both the UV and visible light energy that can cause fabric fading. This rating has also been referred to as the Krochmann Damage Function. This rating better predicts fading potential than UV transmission alone. The lower the Damage Function rating, the less transmission of short-wave energy through the glass that can potentially cause fabric fading. Fabric type is also a key component of fading potential. 7) Percent relative humidity before condensation occurs at the center of glass, taken using center of glass temperature. 8) Inside glass surface temperatures are taken at the center of glass.
 *This data is accurate as of July 2024. Due to ongoing product changes, updated test results or new industry standards, this data may change over time. Contact your Andersen supplier for current performance information or upgrade options.

PERFORMANCE

NFRC Certified Total Unit Performance for Products With Dual-Pane Glass

This information is for reference only. Performance values vary based on unit size, configurations and options. Contact your Andersen supplier for specific unit data.

Andersen® Product	High Performance Dual-Pane Glass Type	U-Factor ¹	SHGC ²	VT ³		
200 Series Tilt-Wash Double-Hung Windows AND-N-59	Low-E	Without Grilles	0.30	0.32	0.54	
		Simulated Divided Light Grilles	0.30	0.29	0.48	
		Finelight™ Grilles	0.30	0.29	0.48	
		Full Divided Light Grilles	0.31	0.29	0.48	
	Low-E w/HeatLock®	Without Grilles	0.26	0.31	0.53	
		Simulated Divided Light Grilles	0.26	0.28	0.47	
		Finelight Grilles	0.26	0.28	0.47	
		Full Divided Light Grilles	0.28	0.28	0.47	
	Low-E SmartSun™	Without Grilles	0.29	0.21	0.49	
		Simulated Divided Light Grilles	0.29	0.19	0.44	
		Finelight Grilles	0.29	0.19	0.44	
		Energy Spacer Divided Light Grilles	0.29	0.19	0.44	
	Low-E SmartSun w/HeatLock	Without Grilles	0.25	0.21	0.48	
		Simulated Divided Light Grilles	0.25	0.19	0.43	
		Finelight Grilles	0.25	0.19	0.43	
		Energy Spacer Divided Light Grilles	0.25	0.19	0.43	
	200 Series Gliding Windows AND-N-63	Low-E	Without Grilles	0.30	0.32	0.55
			Simulated Divided Light Grilles	0.30	0.29	0.49
			Finelight™ Grilles	0.30	0.29	0.49
			Full Divided Light Grilles	0.31	0.29	0.49
Low-E w/HeatLock®		Without Grilles	0.26	0.31	0.53	
		Simulated Divided Light Grilles	0.26	0.28	0.48	
		Finelight Grilles	0.26	0.28	0.48	
		Full Divided Light Grilles	0.28	0.28	0.48	
Low-E SmartSun™		Without Grilles	0.29	0.21	0.49	
		Simulated Divided Light Grilles	0.29	0.19	0.44	
		Finelight Grilles	0.29	0.19	0.44	
		Energy Spacer Divided Light Grilles	0.29	0.19	0.44	
Low-E SmartSun w/HeatLock		Without Grilles	0.26	0.21	0.48	
		Simulated Divided Light Grilles	0.26	0.19	0.43	
		Finelight Grilles	0.26	0.19	0.43	
		Energy Spacer Divided Light Grilles	0.26	0.19	0.43	
Low-E Full Divided Light Grilles		Without Grilles	0.28	0.19	0.43	
		Simulated Divided Light Grilles	0.28	0.19	0.43	
		Finelight Grilles	0.28	0.19	0.43	
		Energy Spacer Divided Light Grilles	0.28	0.19	0.43	

Andersen® Product	High Performance Dual-Pane Glass Type	U-Factor ¹	SHGC ²	VT ³		
200 Series Tilt-Wash Half Circle, Picture and Transom Windows AND-N-60	Low-E	Without Grilles	0.28	0.33	0.56	
		Simulated Divided Light Grilles	0.28	0.30	0.50	
		Finelight™ Grilles	0.28	0.30	0.50	
		Full Divided Light Grilles	0.30	0.30	0.50	
	Low-E w/HeatLock®	Without Grilles	0.24	0.32	0.55	
		Simulated Divided Light Grilles	0.24	0.29	0.49	
		Finelight Grilles	0.24	0.29	0.49	
		Full Divided Light Grilles	0.26	0.29	0.49	
	Low-E SmartSun™	Without Grilles	0.27	0.22	0.51	
		Simulated Divided Light Grilles	0.27	0.20	0.45	
		Finelight Grilles	0.27	0.20	0.45	
		Energy Spacer Divided Light Grilles	0.27	0.20	0.45	
	Low-E SmartSun w/HeatLock	Without Grilles	0.23	0.21	0.50	
		Simulated Divided Light Grilles	0.23	0.19	0.44	
		Finelight Grilles	0.23	0.19	0.44	
		Energy Spacer Divided Light Grilles	0.23	0.19	0.44	
	200 Series Narroline® Gliding Patio Doors AND-N-61	Low-E	Without Grilles	0.29	0.32	0.55
			Simulated Divided Light Grilles	0.29	0.29	0.48
			Finelight™ Grilles	0.29	0.29	0.48
			Full Divided Light Grilles	0.30	0.29	0.48
Low-E w/HeatLock®		Without Grilles	0.25	0.32	0.54	
		Simulated Divided Light Grilles	0.25	0.28	0.47	
		Finelight Grilles	0.25	0.28	0.47	
		Full Divided Light Grilles	0.27	0.25	0.41	
Low-E Sun		Without Grilles	0.29	0.20	0.31	
		Simulated Divided Light Grilles	0.29	0.18	0.27	
		Finelight Grilles	0.29	0.18	0.27	
		Full Divided Light Grilles	0.31	0.18	0.27	
Low-E SmartSun™		Without Grilles	0.28	0.21	0.50	
		Simulated Divided Light Grilles	0.28	0.19	0.44	
		Finelight Grilles	0.28	0.19	0.44	
		Energy Spacer Divided Light Grilles	0.28	0.19	0.43	
Low-E SmartSun w/HeatLock		Without Grilles	0.24	0.21	0.49	
		Simulated Divided Light Grilles	0.24	0.19	0.43	
		Finelight Grilles	0.24	0.19	0.43	
		Energy Spacer Divided Light Grilles	0.24	0.19	0.42	
Low-E Full Divided Light Grilles	Without Grilles	0.27	0.17	0.37		
	Simulated Divided Light Grilles	0.27	0.17	0.37		
	Finelight Grilles	0.27	0.17	0.37		
	Energy Spacer Divided Light Grilles	0.27	0.17	0.37		

continued on next page

1) U-Factor defines the amount of heat loss through the total unit in BTU/hr-ft²-°F. The lower the value, the less heat is lost through the entire product. Window values represent non-tempered glass. Use of tempered glass can increase U-Factor ratings. See andersenwindows.com/nfrc for specific performance values. Door values represent tempered glass. 2) Solar Heat Gain Coefficient (SHGC) defines the fraction of solar radiation admitted through the glass directly transmitted, as well as absorbed and subsequently released inward. The lower the value, the less heat is transmitted through the product. 3) Visible Transmittance (VT) measures how much light comes through a product (glass and frame). The higher the value, from 0 to 1, the more daylight the product lets in over the product's total unit area. Visible light transmittance is measured over the 380-760 nanometer portion of the solar spectrum. * NFRC ratings are based on modeling by a third-party agency as validated by an independent test lab in compliance with NFRC program and procedural requirements. * This data is accurate as of July 2024. Due to ongoing product changes, updated test results, or new industry standards or requirements, this data may change over time. Ratings are for sizes specified by NFRC for testing and certification. Ratings may vary depending on unit size, use of tempered glass, different grille options, glass for high altitudes, etc. * Values are for single units with given pane thickness and 3/4" (19 mm) grilles for windows and 1" (25 mm) grilles for door products.

NFRC Certified Total Unit Performance for Products With Dual-Pane Glass

This information is for reference only. Performance values vary based on unit size, configurations and options. Contact your Andersen supplier for specific unit data. (continued)

Andersen® Product	High Performance Dual-Pane Glass Type	U-Factor ¹	SHGC ²	VT ³	
200 Series Perma-Shield® Gliding Patio Doors AND-N-13	Low-E ⁴	Without Grilles	0.28	0.32	0.56
		Blinds-Between-the-Glass ²	0.34	0.32	0.56
		Simulated Divided Light Grilles	0.28	0.29	0.49
		Finelight™ Grilles	0.28	0.29	0.49
		Full Divided Light Grilles	0.31	1.76	0.29
	Low-E ⁴ w/HeatLock®	Without Grilles	0.24	0.32	0.54
		Simulated Divided Light Grilles	0.24	0.28	0.48
		Finelight Grilles	0.24	0.28	0.48
		Full Divided Light Grilles	0.28	1.59	0.28
		Without Grilles	0.29	0.20	0.31
	Low-E ⁴ Sun	Simulated Divided Light Grilles	0.29	0.18	0.27
		Finelight Grilles	0.29	0.18	0.27
		Full Divided Light Grilles	0.31	1.76	0.18
		Without Grilles	0.28	0.21	0.50
	Low-E ⁴ SmartSun™	Simulated Divided Light Grilles	0.28	0.19	0.44
		Finelight Grilles	0.28	0.19	0.44
		Energy Spacer Divided Light Grilles	0.28	1.59	0.19
		Full Divided Light Grilles	0.30	1.70	0.19
		Without Grilles	0.24	0.21	0.49
	Low-E ⁴ SmartSun w/HeatLock	Simulated Divided Light Grilles	0.24	0.19	0.43
Finelight Grilles		0.24	0.19	0.43	
Energy Spacer Divided Light Grilles		0.24	1.36	0.19	
Full Divided Light Grilles		0.27	1.53	0.19	
Without Grilles		0.30	0.24	0.41	
200 Series Hinged Inswing Patio Doors AND-N-75	Low-E	Simulated Divided Light Grilles	0.30	0.21	0.35
		Finelight™ Grilles	0.30	0.21	0.35
		Full Divided Light Grilles	0.32	1.82	0.21
		Without Grilles	0.27	0.24	0.40
	Low-E w/HeatLock®	Simulated Divided Light Grilles	0.27	0.21	0.34
		Finelight Grilles	0.27	0.21	0.34
		Full Divided Light Grilles	0.30	1.70	0.21
	Low-E Sun	Without Grilles	0.31	0.15	0.23
		Simulated Divided Light Grilles	0.31	0.13	0.19
		Finelight Grilles	0.31	0.13	0.19
		Full Divided Light Grilles	0.32	1.82	0.11
	Low-E SmartSun™	Without Grilles	0.30	0.16	0.37
		Simulated Divided Light Grilles	0.30	0.14	0.31
		Finelight Grilles	0.30	0.14	0.31
		Energy Spacer Divided Light Grilles	0.30	1.70	0.14
		Full Divided Light Grilles	0.31	1.76	0.12
	Low-E SmartSun w/HeatLock	Without Grilles	0.27	0.16	0.36
		Simulated Divided Light Grilles	0.27	0.14	0.31
		Finelight Grilles	0.27	0.14	0.31
		Energy Spacer Divided Light Grilles	0.30	1.70	0.12
Full Divided Light Grilles		0.27	1.53	0.14	

NFRC Certified Total Unit Performance for Products With Triple-Pane Glass

This information is for reference only. Performance values vary based on unit size, configurations and options. Contact your Andersen supplier for specific unit data.

Andersen® Product	High-Performance Triple-Pane Glass Type	U-Factor ¹	SHGC ²	VT ³	
200 Series Narroline® Gliding Patio Doors AND-N-61	Low-E	Without Grilles	0.26	0.30	0.51
		Simulated Divided Light Grilles	0.26	0.27	0.44
		Finelight™ Grilles	0.27	0.27	0.44
		Full Divided Light Grilles	-	-	-
		Without Grilles	0.22	0.29	0.49
	Low-E Enhanced	Simulated Divided Light Grilles	0.22	0.26	0.43
		Finelight Grilles	0.23	0.26	0.43
		Full Divided Light Grilles	-	-	-
		Without Grilles	0.20	0.28	0.48
	Low-E Enhanced w/HeatLock®	Simulated Divided Light Grilles	0.20	0.25	0.42
		Finelight Grilles	0.21	0.25	0.42
		Full Divided Light Grilles	-	-	-
	Low-E SmartSun™	Without Grilles	0.26	0.20	0.46
		Simulated Divided Light Grilles	0.26	0.18	0.40
		Finelight Grilles	0.26	0.18	0.40
		Full Divided Light Grilles	-	-	-
	Low-E SmartSun Enhanced	Without Grilles	0.22	0.19	0.44
		Simulated Divided Light Grilles	0.22	0.17	0.38
		Finelight Grilles	0.22	0.17	0.38
		Full Divided Light Grilles	-	-	-
Low-E SmartSun Enhanced w/HeatLock	Without Grilles	0.20	0.19	0.43	
	Simulated Divided Light Grilles	0.20	0.17	0.37	
	Finelight Grilles	0.20	0.17	0.37	
	Full Divided Light Grilles	-	-	-	
	Without Grilles	0.26	1.48	0.30	
Low-E	Simulated Divided Light Grilles	0.26	1.48	0.27	
	Finelight™ Grilles	0.27	1.53	0.27	
	Full Divided Light Grilles	-	-	-	
	Without Grilles	0.22	1.25	0.29	
Low-E Enhanced	Simulated Divided Light Grilles	0.22	1.25	0.26	
	Finelight Grilles	0.22	1.25	0.26	
	Full Divided Light Grilles	-	-	-	
Low-E Enhanced w/HeatLock®	Without Grilles	0.20	1.14	0.28	
	Simulated Divided Light Grilles	0.20	1.14	0.25	
	Finelight Grilles	0.20	1.14	0.25	
	Full Divided Light Grilles	-	-	-	
200 Series Perma-Shield® Gliding Patio Doors AND-N-13	Low-E SmartSun™	Without Grilles	0.25	1.42	0.20
		Simulated Divided Light Grilles	0.25	1.42	0.18
		Finelight Grilles	0.26	1.48	0.18
		Full Divided Light Grilles	-	-	-
	Low-E SmartSun Enhanced	Without Grilles	0.22	1.25	0.20
Low-E SmartSun Enhanced	Simulated Divided Light Grilles	0.22	1.25	0.17	
	Finelight Grilles	0.22	1.25	0.17	
	Full Divided Light Grilles	-	-	-	
	Without Grilles	0.20	1.14	0.19	
Low-E SmartSun Enhanced w/HeatLock	Simulated Divided Light Grilles	0.20	1.14	0.17	
	Finelight Grilles	0.20	1.14	0.17	
	Full Divided Light Grilles	-	-	-	

1) U-Factor defines the amount of heat loss through the total unit in BTU/hr-ft²-°F. The lower the value, the less heat is lost through the entire product. Window values represent non-tempered glass. Use of tempered glass can increase U-Factor ratings. See andersenwindows.com/nfrc for specific performance values. Door values represent tempered glass. 2) Solar Heat Gain Coefficient (SHGC) defines the fraction of solar radiation admitted through the glass directly transmitted, as well as absorbed and subsequently released inward. The lower the value, the less heat is transmitted through the product. 3) Visible Transmittance (VT) measures how much light comes through a product (glass and frame). The higher the value, from 0 to 1, the more daylight the product lets in over the product's total unit area. Visible light transmittance is measured over the 380-760 nanometer portion of the solar spectrum. • NFRC ratings are based on modeling by a third-party agency as validated by an independent test lab in compliance with NFRC program and procedural requirements. • This data is accurate as of July 2024. Due to ongoing product changes, updated test results, or new industry standards or requirements, this data may change over time. Ratings are for sizes specified by NFRC for testing and certification. Ratings may vary depending on unit size, use of tempered glass, different grille options, glass for high altitudes, etc. • Values are for single units with given pane thickness and 3/4" (19 mm) grilles for windows and 1" (25 mm) grilles for door products.

Combination Designs,
Product Performance
& Installation

PERFORMANCE

About the Label

Look for this certification label on every window and patio door you buy. The NFRC section was designed by the National Fenestration Rating Council to provide accurate information that helps you promote the energy efficiency of the homes you build. These ratings allow you – and your customers – to measure and compare the energy performance of similar products. If the product does not have this label, the NFRC has not verified its claims.

About the NFRC

The National Fenestration Rating Council (NFRC) is a nonpartisan coalition of professionals whose purpose is to provide fair, accurate and credible energy performance ratings for fenestration products. NFRC's membership includes manufacturers, suppliers, designers, specifiers, utility companies, government agencies and other building industry representatives.

Andersen Corporation is a founding member of the NFRC and continues to support its work by providing fair, accurate and credible energy performance ratings to consumers and the building industry. If you have any questions about the NFRC, its program or energy performance ratings, write them at: NFRC, 6305 Ivy Lane, Suite 410, Greenbelt, MD 20770. Phone: 301-589-1776. Website: nfrf.org

U-Factor indicates how well a product prevents heat from escaping (the lower the number, the better).

Visible Transmittance refers to how much visible light comes through a product (the closer to 1.0, the more light is transmitted).

WDMA Hallmark Certification verifies the performance ratings of this product were tested by an independent testing laboratory and verified by a third-party certification program.

Test Standards

Energy Rating (ER) represents "Energy Rating" and is a rating used in Canada for product comparison purposes (the higher the ER number, the more energy saved during the heating season).

ENERGY STAR® Climate Zone Map is based on U-Factor and solar heat gain coefficient criteria for specific ENERGY STAR climate zones within the United States and Canada. The shading of the map shows which climate zone(s) a particular product and glass type is ENERGY STAR Version 7.0 certified in. Visit andersenwindows.com/energystar for more details.

Solar Heat Gain Coefficient measures how well a product blocks heat caused by sunlight (the lower the number, the more it will help reduce the use of air conditioning and as a result, reduce electrical bills and energy use).

Performance Grade (PG) and Design Pressure (DP) Ratings

Glass Construction used with this product type.

Do not remove until final code inspection. Save label for future reference.

ENERGY STAR® Certified in Highlighted Regions
Certifié ENERGY STAR dans les régions en surbrillance

Canada
energystar.gc.ca

ENERGY STAR

U.S. / É.U.
energystar.gov

ER/RE 15

ANDERSEN®
WINDOWS & DOORS

Tilt-Wash Double-Hung Window
AND-N-59-01692-00001
Vinyl-Clad Wood Frame, Dual-Pane Low-E SmartSun
Glazing with Argon
Product Type: Vertical Slider

ENERGY PERFORMANCE RATINGS

U-Factor 0.29 (U.S./I-P)	1.65 (Metric/SI)	Solar Heat Gain Coefficient 0.21
---------------------------------------	----------------------------	--

ADDITIONAL PERFORMANCE RATINGS

Visible Transmittance 0.49	
--------------------------------------	--

Manufacturer stipulates that these ratings conform to applicable NFRC procedures for determining whole product performance. NFRC ratings are determined for a fixed set of environmental conditions and a specific product size. NFRC does not recommend any product and does not warrant the suitability of any product for any specific use. Consult manufacturer's literature for other product performance information.
www.nfrc.org

WDMA
Hallmark Certified
www.wdma.com

Licensee: 129-H-731
Andersen Corporation
200 Series Tilt-Wash Double-Hung Window
Manufacturer stipulates Hallmark Certification as indicated below.

STANDARD	RATING
AAMA-WDMA/CSA 1011.S.2/A440-11	Class R-PC30 Size Tested 39.5" x 71.5" DP+30-30
AAMA-WDMA/CSA 1011.S.2/A440-08	Class R-PC30 Size Tested 39.5" x 71.5" DP+30-30
AAMA-WDMA/CSA 1011.S.2/A440-08 A440(S)-09	Class R-PC30 Size Tested 1003 mm x 1816 mm Positive/Negative Design Pressure (DP) = 1440 Pa/-1440 Pa Water Penetration Resistance Test Pressure = 220 Pa Canadian Air Infiltration/Exfiltration = A3

FL 15752 Complies with HUD UM Bulletin No. 111.
Glazing: 2.2 mm AN outer / 2.3 mm HS inner

WARNING
This product can expose you to chemicals including titanium dioxide, which is known in the state of California to cause cancer, and methanol, which is known to the state of California to cause birth defects or other reproductive harm.
For more information go to www.P65Warnings.ca.gov

Meets or exceeds CEC & IECC Air Infiltration Requirements of 0.2 CFM/sq.ft. or lower.
WDMA Hallmark Certification Program.

* NFRC ratings are based on modeling by a third-party agency as validated by an independent test lab in compliance with NFRC program and procedural requirements.
* "ENERGY STAR" is a registered trademark of the U.S. Environmental Protection Agency.

INSTALLATION ACCESSORIES & MATERIALS

Optional installation accessories and materials are available for installing Andersen® windows and patio doors. Keep instructions and safety information in mind when considering the installation and use of any Andersen product. For more information, contact your Andersen supplier or visit andersenwindows.com/installmaterials.

Extension Jamb



Available for most Andersen products. See product sections for details.

Fibrex® Trim Board



This solid cellular Fibrex trim board can be cut or ripped to size, and fastened using nails or screws. 3 1/2" (89) x 3/4" (19) thick in 10' (3048) lengths. Available in white, canvas, prairie grass, Sandtone, Terratone, cocoa bean, dark bronze, red rock, forest green, dove gray and black.

Vinyl Channels

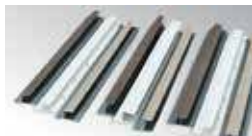

Rigid vinyl "J" and "h" channels are 1/2" (13) deep and come in 150" (3810) lengths. "J" channels are 3/4" (19) wide and "h" channels are 1" (25) wide. "J" and "h" channels are available in white, Sandtone and Terratone. "H" channels are 3/4" (19) deep and come in 84" (2134) and 150" (3810) lengths. White "H" channels are 3/4" (19) wide. Sandtone and Terratone "H" channels are 1" (25) wide.

Auxiliary Casing



Made of cellular Fibrex material. 1 3/16" (30) x 1 3/16" (30) thick in 150" (3810) lengths. Available in white, canvas, Sandtone, Terratone, dark bronze, forest green and black.

Drip Cap

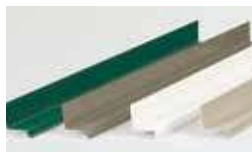

Included on 200 Series windows with vertical (ribbon) joins. Made from heavy 24-gauge corrosion-resistant aluminum construction and comes in 6' (1829), 10' (3048) and 12'-7 1/2" (3848) lengths. Available in white, canvas, prairie grass, Sandtone, Terratone, cocoa bean, dark bronze, red rock, forest green, dove gray and black.

Coil Stock



Made from .018"-thick aluminum, Andersen coil stock is available in 24" (610) x 50' (15240) rolls and can be ordered in white, canvas, prairie grass, Sandtone, Terratone, cocoa bean, dark bronze, red rock, forest green, dove gray and black. Color-matched 1 1/4" (32)-long stainless steel trim nails are also available and can be ordered in 1 lb/.454 kg boxes. Coil stock can be cut and formed to profiles at the job site.

Straight Flashing Tape



A superior product that provides excellent adhesion to all Andersen product substrates and common building materials. Asphalt and solvent free, with a wide application temperature range and split release liner for easy and accurate application. Available in 4" (102) or 6" (152) widths in 33' (10058) or 75' (22860) lengths in a single roll or full pallet.

Color-Matched Sealant

This high-performance sealant provides excellent durability and adhesion to Andersen product substrates and common building materials. Paintable after one hour and can be applied from 10°F to 110°F. Color-matched sealant in white, canvas, prairie grass, Sandtone, Terratone, cocoa bean, dark bronze, red rock, forest green, dove gray and black, is available in a single 10.1 ounce tube or a 20 ounce foil pack. White, dark bronze and black colors in both sizes are available in a full or a half pallet.



Installation Foam

A minimally expanding low-pressure build foam that remains soft and pliable. Trimmable in as little as one hour, it repels moisture and offers superior performance in a wide range of environments. Available in a single 20 ounce commercial can or in a full pallet.



Shims

Flat self-hanging shims help with a secure installation. Available in boxes of 248 shims.

Installation Screws

Properly sized installation screws are provided for windows that will be secured through the jamb.

Foam Backer Rod

3/8" (10) backer rod helps provide an air seal around the frame. Available in 100' (30480) rolls.

INSTALLATION INFORMATION

ROUGH OPENINGS

The purpose of a rough opening is to allow for proper spacing between the window or patio door unit and the building structure. The space is required for locating, leveling and squaring the unit during installation and to provide an area for insulation. A rough opening that is incorrectly sized may affect unit operation and may not allow for adequate fastening of the unit to the building structure. Andersen® rough opening dimensions are provided as a guideline to help determine the minimum amount of space needed between the window or patio door and the building structure. See appropriate product sections for rough opening guidelines for each product.

Keep in mind that rough opening dimensions may need to be altered from published guidelines, depending on installation methods, joining methods, replacement methods, etc. For example, flashing systems can reduce the amount of available rough opening space and should be factored in when calculating rough opening dimensions. The use of support or joining materials will encroach on the rough opening and may require additional rough opening space between the unit and the building structure, depending on the thickness of the flashing system and joining materials used. To facilitate drainage, the rough opening sill plate should never slope toward the interior. For challenging environments and other information, refer to EEBA's (Energy and Environmental Building Association) Water Management Guide (eeba.org).

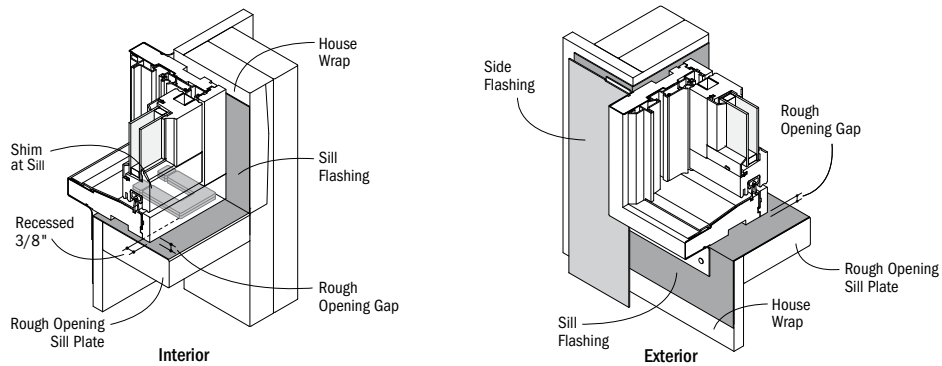

Interior and exterior example of window sill flashing in a membrane drainage system.

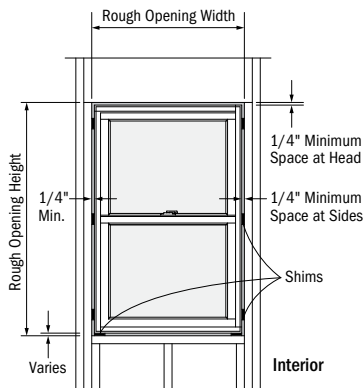

Example of window unit installed using Andersen published minimum rough opening dimensions.

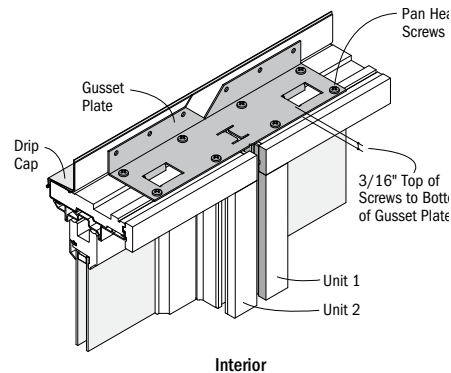

Example of two units joined together with the use of gusset plates and pan head screws that will require additional rough opening space.

IMPORTANCE OF PROPER INSTALLATION

Proper installation and maintenance of Andersen products is essential to attain optimum performance and operation. Installation instructions that provide guidelines for proper installation are typically provided with Andersen products. They are also available by visiting andersenwindows.com. Remember that every installation is different, and Andersen strongly recommends consultation with the local supplier or an experienced contractor, architect or structural engineer prior to the installation of any Andersen product. The method of attachment for Andersen products, fastener selection and code compliance is the responsibility of the architect, building owner, contractor, installer and/or consumer. For more complete installation details, visit andersenwindows.com or see your Andersen supplier.

GENERAL NOTES

When ordering, make certain you specify, then verify, the exact product, unit dimensions, configuration requirements, color and options you desire on each window or patio door. Before installing the product, we suggest you verify that it includes the features and options you ordered. Visit andersenwindows.com for product installation and joining guides. Printing limitations prohibit exact color duplication of products. View actual samples for building specifications. Andersen Corporation reserves the right to change details, specifications or sizes without notice. The customer assumes all risk of alterations made to Andersen products.

CODES

Appropriate selection of Andersen products that conform to all applicable laws, ordinances, building codes and safety requirements is the sole responsibility of the architect, designer, building owner and/or contractor. Check with your local building code officials for specific information. Unit wind load, performance grade and energy performance information is provided on pages 57-72. For up-to-date product performance information, visit andersenwindows.com. The performance of any building system depends on the design and construction of the building system in its entirety, which should meet building code requirements, as well as address product and material limitations, and local environment and climate.

DRIP CAPS

Drip caps are a specific type of flashing or trim used at the head of a window or door to direct water from the drainage plane out beyond the face of the unit.

FLASHING

Flashing is an important element in a building's water management system. It is used to shed and direct water to the building exterior or to the drainage plane. Flashing materials are typically applied starting from the bottom and working upward, with each successive layer overlapping the previous one in shingle fashion. Water infiltration problems in any type of building can be reduced by properly flashing and/or sealing around all building openings, including windows and doors.

USE OF SHIMS

Shims are used along the side jambs of windows and doors to center the unit in the rough opening and to position it plumb, level and square. In addition, shims are always required for windows under the sill at the side jambs to lift it off the rough opening sill plate. Shims also enable a straight frame for proper weatherstrip contact and unit operation. If not placed properly, unit performance and operation can be affected. Use waterproof shims capable of supporting the weight of the product. When using tapered shims, use them in pairs with the tapers opposing each other to avoid tilting the unit or twisting (rotating) of the jambs.

SEALANTS

Sealants are elastic materials used to block the passage of water and/or air while allowing movement between the two sides of the joint. A sealant should bond tightly, and be able to expand and contract to accommodate joint movement without cracking or tearing away from the substrate. Surfaces must be clean, dry and sound for adequate sealant adhesion. Choose a sealant that is compatible with, and that will adhere adequately to, all building materials used in the window and patio door area. Proper sealant joint design is based upon the expected movement of adjacent materials and the movement capability of the sealant. A general rule of thumb is that the depth of the sealant joint should be equal to half the width ($D = W/2$), but generally not less than $1/4"$ (6) or more than $1/2"$ (13). Foam-plastic backer rod can be used to limit the depth of the sealant joint, to provide a backstop for tooling the sealant without damage to the bond. It also acts as a bond breaker to help minimize stress in the sealant. Sealants should be maintained seasonally, and repaired and/or replaced as needed.

Dimensions in parentheses are in millimeters.

GENERAL INSTALLATION GUIDELINES

1. Read and follow the installation guide in its entirety.
2. Decide whether you are integrating to a surface barrier or a membrane drainage system before installing the product. The appropriate method for your installation may vary based on building design, application and industry practices.
3. Make certain the drainage plane is continuous (proper overlaps to shed water, taped seams, etc.).
4. Andersen products should be installed only in the vertical position.
5. Check the rough opening to make sure it is sized properly, is square and is level.
6. Install the window or door plumb.
7. Install the window or door level.
8. Install the window or door square. Diagonal measurements should be within $1/8"$ (3).
9. Follow installation instructions to properly locate shims and to make sure that units are plumb, level and square. Shims are always required under the window jambs at the sill and along the jambs on the sides for windows and doors.
10. Check for squareness of unit before final anchoring of the product into the wall.
11. Anchor unit as directed with appropriate fasteners.
12. Integrate the window and door into the drainage plane of the wall using quality flashing and sealing materials. All flashing materials should be properly overlapped to shed water.
13. Allow $1/4"$ (6) minimum space for a sealant joint around perimeter of unit between exterior finish materials and unit.
14. Insulate and seal the interior cavity between the window or door frame and the rough opening.
15. Check operation before application of interior trim.
16. Stain and/or seal all unfinished wood surfaces promptly to minimize moisture absorption.

EXTERIOR PAINTING/SEALING OF ANDERSEN® PRODUCTS

The exterior of some Andersen products may be painted or stained. However, improper painting and staining may cause damage to vinyl, aluminum and other exterior materials. Please refer to the individual product sections for details on painting Andersen product exteriors.

CAUTIONS

1. Do not apply any type of film to insulating glass. Thermal stress and glass damage can result. Andersen Corporation is not responsible for product performance when films are applied to Andersen products.
2. The use of removable insulating materials such as insulated window coverings, shutters and other shading devices may also cause thermal stress conditions and/or deformation of protective vinyl. In addition, excessive condensation may result, which can have a deteriorating effect on the window or door unit(s) involved. Andersen Corporation is not responsible for product performance when these kinds of materials or devices are applied to or used in conjunction with Andersen products.
3. In wall construction utilizing brick facades, leave adequate clearance between sill, jambs and brick for sealing and dimensional change of framework.

4. Acid solutions commonly used to wash brick and other masonry materials will damage glass, fasteners, hardware and metal flashing. Protect unit and follow cleaning product instructions carefully. Damage caused by acid solution is not covered under the Andersen limited warranty.
5. Andersen windows may be combined in almost unlimited ribbons or stacks if each unit is positively secured to structural elements on opposing sides and if the proper joining system is used. See pages 57-64 for more information.
6. Installing Andersen windows and doors into high humidity and/or chemically saturated environments such as a shower or pool may cause damage not covered under the terms of the limited warranty. Avoid interior direct water exposure. Additional product modifications and maintenance may be required.

SAFETY GLASS

Unless specifically ordered, Andersen windows are not made with safety glass and, if broken, the glass could fragment, causing injury. Andersen windows may be ordered with tempered glass which may reduce the likelihood of injury when broken. All Andersen patio doors are made with tempered glass. Differences in appearance between tempered and non-tempered glass can be expected. Slight visual distortions may be noticeable and occur normally as a result of the tempering process. Building codes require safety glass in locations adjacent to or near doors and other locations.

WINDOW AND PATIO DOOR SAFETY

Windows may provide a secondary avenue of escape or rescue in an emergency, such as a fire. Every family should develop an escape plan and make sure family members know how to escape from the home in an emergency. In your plan, include two ways to escape from every room in case one way is blocked by fire or smoke, and make sure you have a designated meeting place outside. A window or a patio door is an alternate means of escape or rescue. Practice your plan until each member of the family understands it and is able to escape without assistance. Remember, you may not be able to reach children during a fire emergency. Teach children — even very young children — that they must escape from a fire in the home and never hide from the fire or from emergency personnel.

LOOKOUT FOR KIDS® PROGRAM

The Consumer Product Safety Commission has said: "Keep children away from open windows to prevent falls. Don't depend on insect screens to keep the child from falling out of the window. They are designed to keep insects out, not children in. Avoid placing furniture near windows to keep children from climbing to a window seat or sill." In an effort to educate consumers about the potential for child falls from windows, Andersen Corporation created the LookOut For Kids Program. It combines a window and door safety brochure and specific product instructions to help make window and door safety an important priority for consumers. For more information on child safety, write:

Andersen Corporation
LookOut For Kids Program
 100 Fourth Avenue North
 Bayport, MN 55003
 Call: 800-313-8889
 Email: lofk@andersencorp.com
 Website: andersenwindows.com/windowsafety

**LOOK
 OUT!**
 for kids®

Combination Designs,
 Product Performance
 & Installation

THE ENVIRONMENT HAS A BUSINESS PARTNER

Respect for the environment is nothing new at Andersen. For more than a century, it has been part of who we are. Our commitment to recycle and reclaim materials began simply because it was good business. Now it's part of our broader commitment to sustainability and responsible stewardship of all of our resources. Andersen is committed to providing you with long-lasting,* energy-efficient windows and patio doors. Visit andersenwindows.com/sustainability for more information.



Andersen® products are certified under the National Fenestration Rating Council (NFRC) voluntary third-party certification program designed to ensure accurate energy performance ratings and labeling.



The Window & Door Manufacturers Association (WDMA) Hallmark Certification program includes product testing and quality-control process audits to verify that Andersen windows and doors are produced in conformance with the industry standards for air, water resistance and structural performance.



Andersen Corporation is proud to be an ENERGY STAR® partner. For over 120 years, Andersen has built a reputation for environmental stewardship and energy-efficient products. In fact, Andersen has been part of the ENERGY STAR program since it started and was the first window manufacturer to be named an ENERGY STAR National Window Partner of the Year in 1999.



200 Series windows and doors are Indoor Advantage Gold™ certified by SCS Global Services for Indoor Air Quality. Andersen was the first window manufacturer to certify products for indoor air quality, beginning in 2008. For products covered, values and certificate details, visit andersenwindows.com/environmental.



200 Series windows are Recycled Content Certified by SCS Global Services. For values and certificate details, visit andersenwindows.com/environmental.

*Visit andersenwindows.com/warranty for details. All logos and marks are trademarks of their respective owners.



Andersen® windows and patio doors can make significant contributions to the success of sustainable design strategies

As a charter member of the U.S. Green Building Council, we're active supporters of certified green buildings. Our products can help in pursuing green building programs, such as Leadership in Energy and Environmental Design (LEED®), the National Green Building Standard, Green Globes, GreenStar and more. Below is an overview of how our products can help support LEED v4 and NAHB National Green Building Standard certifications. Visit andersenwindows.com/sustainability for more detailed credit summaries.

OUR CERTIFICATIONS THAT CAN CONTRIBUTE TO LEED POINTS:

SCS Global Indoor Air Quality Certification

SCS Global Recycled Content Certification



SUSTAINABILITY CATEGORIES OUR WINDOWS SUPPORT:

LEED for New Construction and Major Renovations

- Integrative process credit
- Energy and atmosphere
- Materials and resources
- Indoor environmental quality

LEED for Homes and Multi-Family Midrisers

- Energy and atmosphere
- Materials and resources
- Indoor environmental quality

ANSI ICC/ASHRAE 700-2015

- Resource efficiency
- Energy efficiency
- Indoor environmental quality



17	200 Series Tilt-Wash Double-Hung Windows
23	200 Series Gliding Windows
29	200 Series Narrowline® Gliding Patio Doors
37	200 Series Perma-Shield® Gliding Patio Doors
43	200 Series Hinged Inswing Patio Doors
51	Exterior Trim
57	Combination Designs, Product Performance & Installation



Printed on FSC® certified paper.



Welcome to an overview of the enhanced navigation tools available in this PDF. Before you begin be sure you are using the latest version of Adobe Acrobat Reader (March 2023), available at – <https://get.adobe.com/reader/>

BOOKMARK NAVIGATION

1

Acrobat will display the bookmarks panel on the right side when you open the PDF.

Bookmarks are the easiest way to find specific product information.

Select a topic and that page will be displayed.

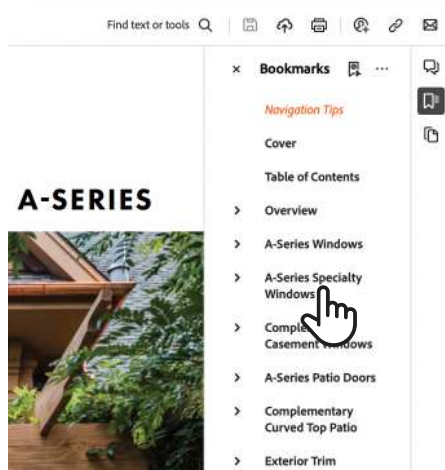

2

In the bookmarks panel you can print a specific section by holding down your **“Ctrl”** key and **clicking** on the section you want to print. Then choose **Print Section**.

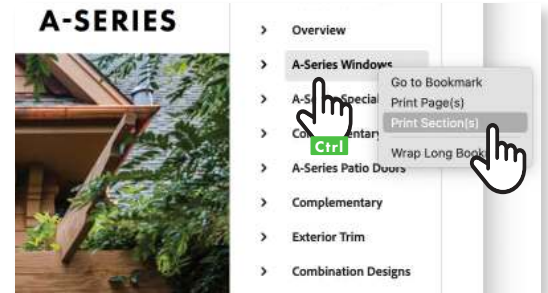

LINKS AND URL NAVIGATION

3

You can also use the **embedded links** to navigate between sections. All links are underlined in blue.



4

Website links automatically open in your web browser.

GLASS SPACER OPTIONS



Black or white glass spacers are available as a standard offering on A-Series products, in addition to stainless steel glass spacers, to provide more ways to

BETWEEN-THE-GLASS ART GLASS

With our between-the-glass art glass you can add interest, create focal points and make your work stand out. See [page 16](#) or visit andersenwindows.com/artglass for more information.

BLINDS-BETWEEN-THE-GLASS FOR PATIO DOORS



PDF NAVIGATION TIPS *(continued)*

TOOL BAR NAVIGATION

5

Top left side navigation tools.



The "commenting" and "highlight" tools here.

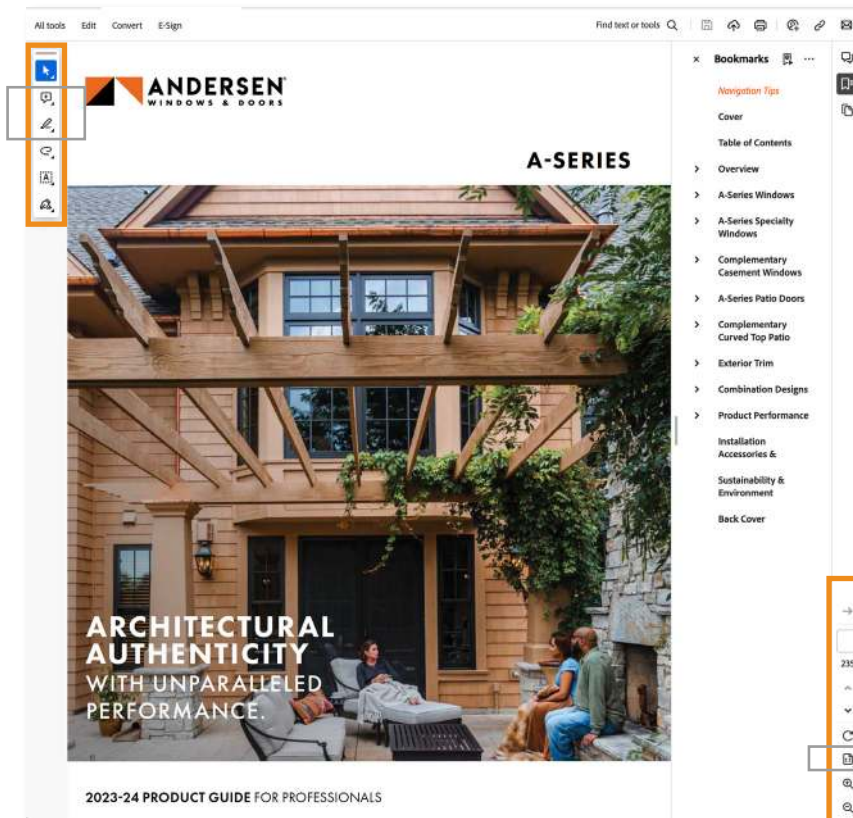

6

Lower right side navigation tools.



Click on the icon shown above to scroll through a list of additional tools.

Add additional navigation tools by adjusting the default settings in Acrobat.

7

Add "Previous View" tool.

Go to the lower right side navigation tools. **Scroll through the list and "pin" the previous view icon**



A left facing arrow will be added to the tool bar allowing you to go back to the previous page you viewed.

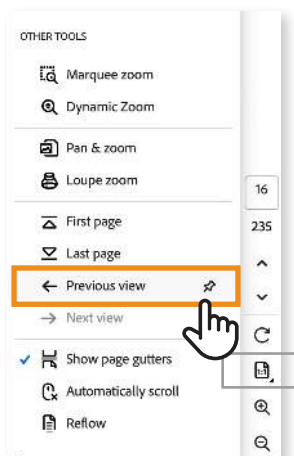

8

Add "Loupe Zoom" tool.

Go to the lower right side navigation tools. **Scroll through the list and "pin" the loupe zoom icon.**



The loupe icon will be added to the tool bar allowing you to zoom in on details without changing the page view.

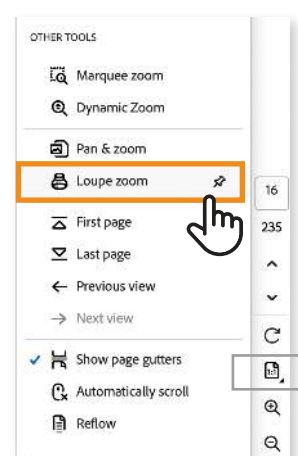

We are always looking for ways to improve.
Please send feedback to webmarketing@andersencorp.com.